



BMW, AUDI, PORSCHE Technicians Guide

INDEX

ZF 4HP-18FLE AND ZF 4HP-18 FLA DIAGNOSTIC INFORMATION

ZF 4HP-22/24 SERIES DIAGNOSTIC INFORMATION

MODEL "E-7" VALVE BODY WITH 5 SOLENOIDS

MODEL "E-9" VALVE BODY WITH 4 SOLENOIDS

ZF 5HP-18 DIAGNOSTIC INFORMATION

ZF 5HP-19FL DIAGNOSTIC INFORMATION

ZF 5HP-24 DIAGNOSTIC INFORMATION

ZF 5HP-30 DIAGNOSTIC INFORMATION



INTRODUCTION

BMW, AUDI, PORSCHE

Published
September, 2003

This booklet contains information that has not normally been available in most OEM repair manuals and can be used by the technician to diagnose electrical concerns, identify the location and direction of the valves, springs, retainers and bore plugs in the valve body. This information has been prepared from actual valve bodies and in some cases may vary from one model to another, but is invaluable when the need arises to diagnose and repair electrical and valve body concerns.

This Manual covers the following models:

- *ZF-4HP-18FLE/FLA Transaxle, found in Audi and Porsche.*
- *ZF-4HP-22/24 Series, Model "E7", "5 Solenoid" Valve Body found in various vehicles.*
- *ZF-4HP-22/24 Series, Model "E9", "4 Solenoid" Valve Body found in various vehicles.*
- *ZF-5HP-18 Series, found in various BMW models.*
- *ZF-5HP-19FL Transaxle, found in various BMW models.*
- *ZF-5HP-24 Series, found in various BMW models.*
- *ZF-5HP-30 Series, found in various BMW models and Rolls Royce.*

No part of any ATSG publication may be reproduced, stored in any retrieval system or transmitted in any form or by any means, including but not limited to electronic, mechanical, photocopying, recording or otherwise, without *written* permission of Automatic Transmission Service Group. This includes all text illustrations, tables and charts.

The information and part numbers contained in this booklet have been carefully compiled from industry sources known for their reliability, but ATSG does not guarantee its accuracy.

Copyright © ATSG 2003

DALE ENGLAND
FIELD SERVICE CONSULTANT

WAYNE COLONNA
TECHNICAL SUPERVISOR

PETER LUBAN
TECHNICAL CONSULTANT

JON GLATSTEIN
TECHNICAL CONSULTANT

JERRY GOTT
TECHNICAL CONSULTANT

GERALD CAMPBELL
TECHNICAL CONSULTANT

JIM DIAL
TECHNICAL CONSULTANT

ED KRUSE
TECHNICAL CONSULTANT

GREGORY LIPNICK
TECHNICAL CONSULTANT

DAVID CHALKER
TECHNICAL CONSULTANT

STANTON ANDERSON
TECHNICAL CONSULTANT

ROLAND ALVAREZ
TECHNICAL CONSULTANT

MIKE SOUZA
TECHNICAL CONSULTANT

AUTOMATIC TRANSMISSION SERVICE GROUP
9200 S. DADELAND BLVD. SUITE 720
MIAMI, FLORIDA 33156
(305) 670-4161

We wish to thank the following for supplying the actual valve bodies that have made these illustrations possible.



LORY
TRANSMISSION
PARTS

2414 SW 8TH STREET
MIAMI, FLORIDA 33135
TOLL FREE (800) 966-4621
PHONE (305) 642-4621
FAX (305) 541-1444

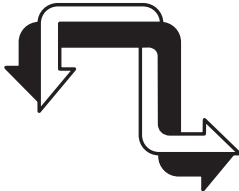

ERIKSSON INDUSTRIES
DIVISION OF
WENTWORTH ENGINEERING, INC.

146 B ELM STREET
OLD SAYBROOK, CT 06475
TOLL FREE (800) 388-4418

INDEPENDENT TRANSMISSION SERVICE
AND MARIO ARISTIDES

5846 SW 68TH STREET
SOUTH MIAMI, FLORIDA 33143
PHONE (305) 666-3544
PHONE (305) 666-4208
FAX (305) 666-8238



TECHNICIANS DIAGNOSTIC GUIDE BMW, AUDI, PORSCHE

ZF-4HP-18FLE AND ZF-4HP-18FLA DIAGNOSTIC INFORMATION

The ZF-4HP-18FLE is mounted longitudinal in the front of the vehicle, and was produced in 2 Wheel Drive models (FLE) and All Wheel Drive (FLA) models, as shown in Figure 1. This unit is totally electronic controlled and is totally different than any 4-HP-18 unit that you are currently familiar with.

ZF-4HP-18FLE And ZF-4HP-18FLA Is Found In The Following Vehicles;

<i>Audi --- 100 Quattro, A6.....</i>	<i>1991-1997</i>
<i>Audi --- A8.....</i>	<i>1994-1996</i>
<i>Porsche --- 944.....</i>	<i>1991-1994</i>

There has been very little pertinent information published on these units. The information in this bulletin has been prepared from an actual transaxle and valve body, and has been formulated to provide you with the preliminary information needed to diagnose and repair electrical and valve body concerns.

Refer to Figure 1 for illustrations of both the 4-HP-18FLE (2WD) and 4-HP-18FLA (AWD) models.

Refer to Figure 2 for internal component resistance charts and connector pin identification.

Refer to Figure 3 for complete wiring schematic with computer terminal identification and transaxle terminal identification, which makes it easier for electrical diagnosis.

Refer to Figure 4 for the solenoid application chart and component application chart.

Refer to Figure 5 for illustration of the complete valve body assembly.

Refer to Figure 6 for exploded view of oil filter and oil filter transfer plate.

Refer to Figure 7 for exploded view of the manual valve body.

Refer to Figure 8 for exploded view of the solenoid body, and notice that it provides you with the factory setting for the adjustment on the pressure regulator valve for EDS-1 solenoid. The Legend for Figure 8 which identifies the solenoid body components and solenoids is found on Page 13.

Refer to Figure 9 for exploded view of the valve body assembly components.

Refer to Figure 10 for exploded detail view of the "Rear Side" of the main valve body. The Legend for Figure 10 which identifies the main valve body components is found on Page 16.

Continued on Page 5

SPECIAL NOTE:

All nomenclatures in this booklet are ATSG interpretations, not Audi's nor ZF.

Copyright © 2001 ATSG



TECHNICIANS DIAGNOSTIC GUIDE BMW, AUDI, PORSCHE

Continued from Page 4.

Refer to Figure 11 for exploded detail view of the "Front Side" of the main valve body.

Refer to Figure 12 for valve body spring specifications. The spring dimensions listed in Figure 12 were "Observations" from only one valve body, and may vary from one model to another.

Refer to Figure 13 for Solenoid Body screen and retainer locations, and to Figure 14 for the Manual Valve Body retainer locations.

Refer to Figure 15 for the Main Valve Body "Top Side" retainer locations, check valve and checkball locations, and the locations of the small flat disc orifices.

Refer to Figure 16 for the Main Valve Body "Bottom Side" check valve location, and the location of the small flat disc orifices.

Refer to Figure 17 for location of the small flat disc orifices in the channel plate.

Refer to Figure 18 for the two pressure tap locations on the back of case.

Refer to Page 22 for explanation of Safety Mode Valve operation.

Refer to Page 23 for complete color hydraulic schematic.

SPECIAL NOTE:

All nomenclatures in this booklet are ATSG interpretations, not Audi's nor ZF.

ZF-4HP-18FLE
(2WD Version)

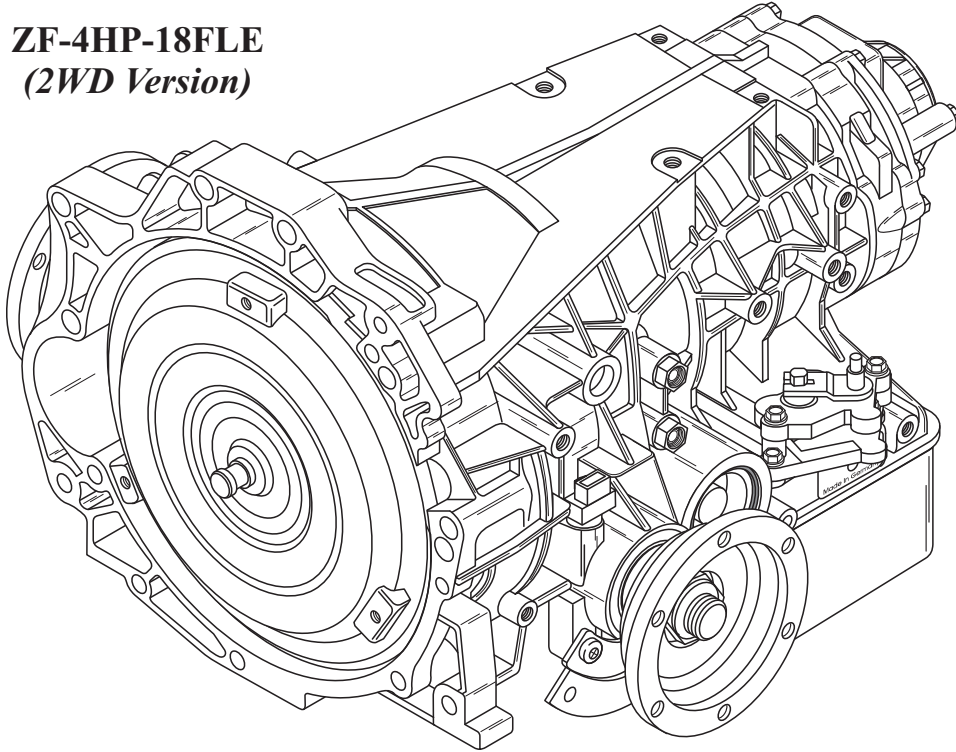

ZF-4HP-18FLA
(AWD Version)

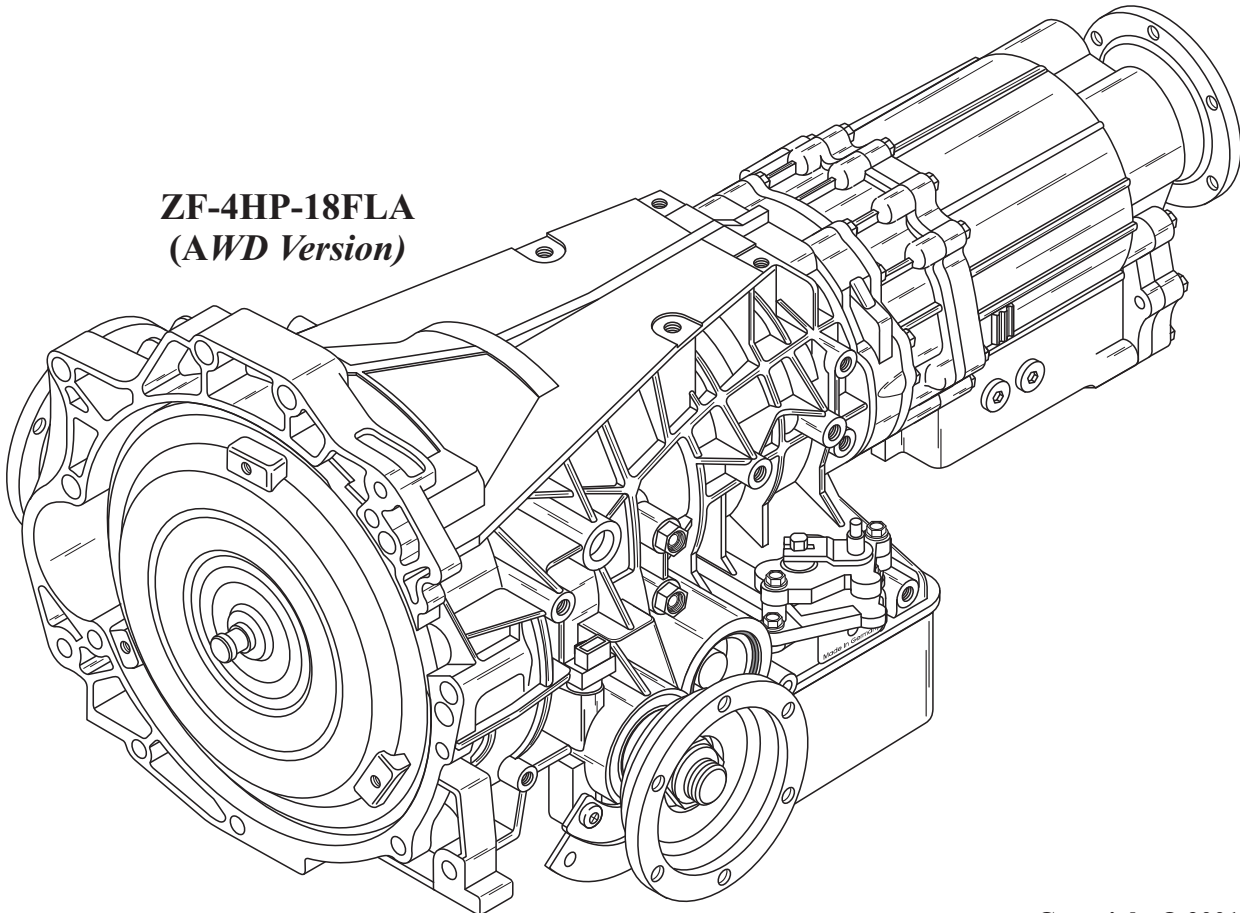

Copyright © 2001 ATSG

Figure 1

RESISTANCE CHARTS AND TERMINAL IDENTIFICATION

Internal Component	Connector Terminals	Resistance In Ohms
MV-1 Solenoid	M & H	30-40 Ohms @ 68°F (20°C)
MV-2 Solenoid	M & K	30-40 Ohms @ 68°F (20°C)
MV-3 Solenoid	M & L	30-40 Ohms @ 68°F (20°C)
EDS-1 Solenoid	M & B	5-8 Ohms @ 68°F (20°C)
TFT Sensor	E & F	920-960 Ohms @ 68°F (20°C)

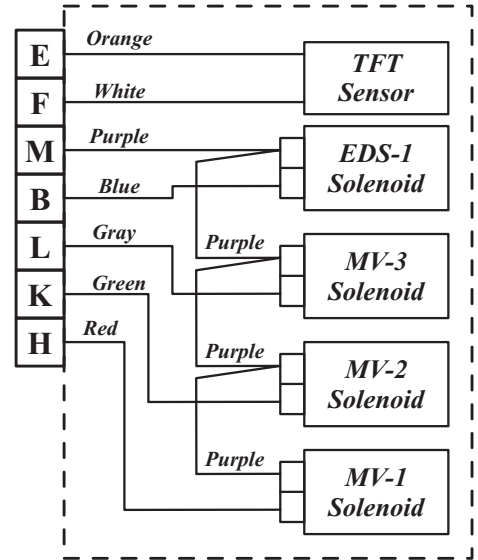

SPECIAL NOTE:

Solenoid nomenclatures are ATSG interpretations, not Audi's nor ZF.

TRANSAXLE SOLENOID CONNECTOR TERMINAL IDENTIFICATION

View Looking Into Vehicle Harness Connector

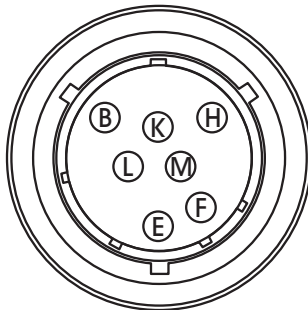

View Looking Into Transaxle Case Connector

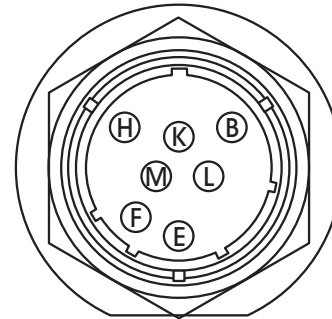

TRANSAXLE RANGE SWITCH CONNECTOR TERMINAL IDENTIFICATION

View Looking Into Transaxle Range Switch Vehicle Harness Connector

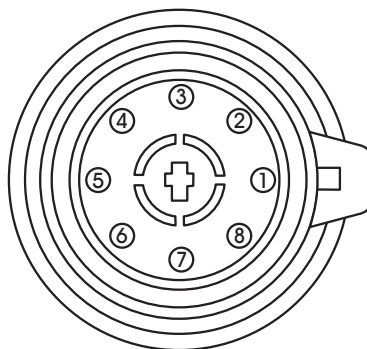

View Looking Into Transaxle Range Switch Connector

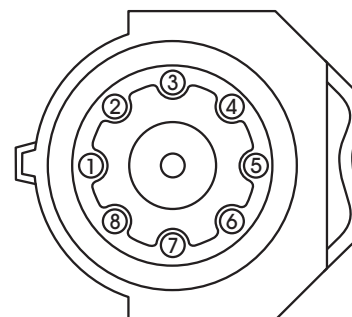

Copyright © 2001 ATSG

Figure 2

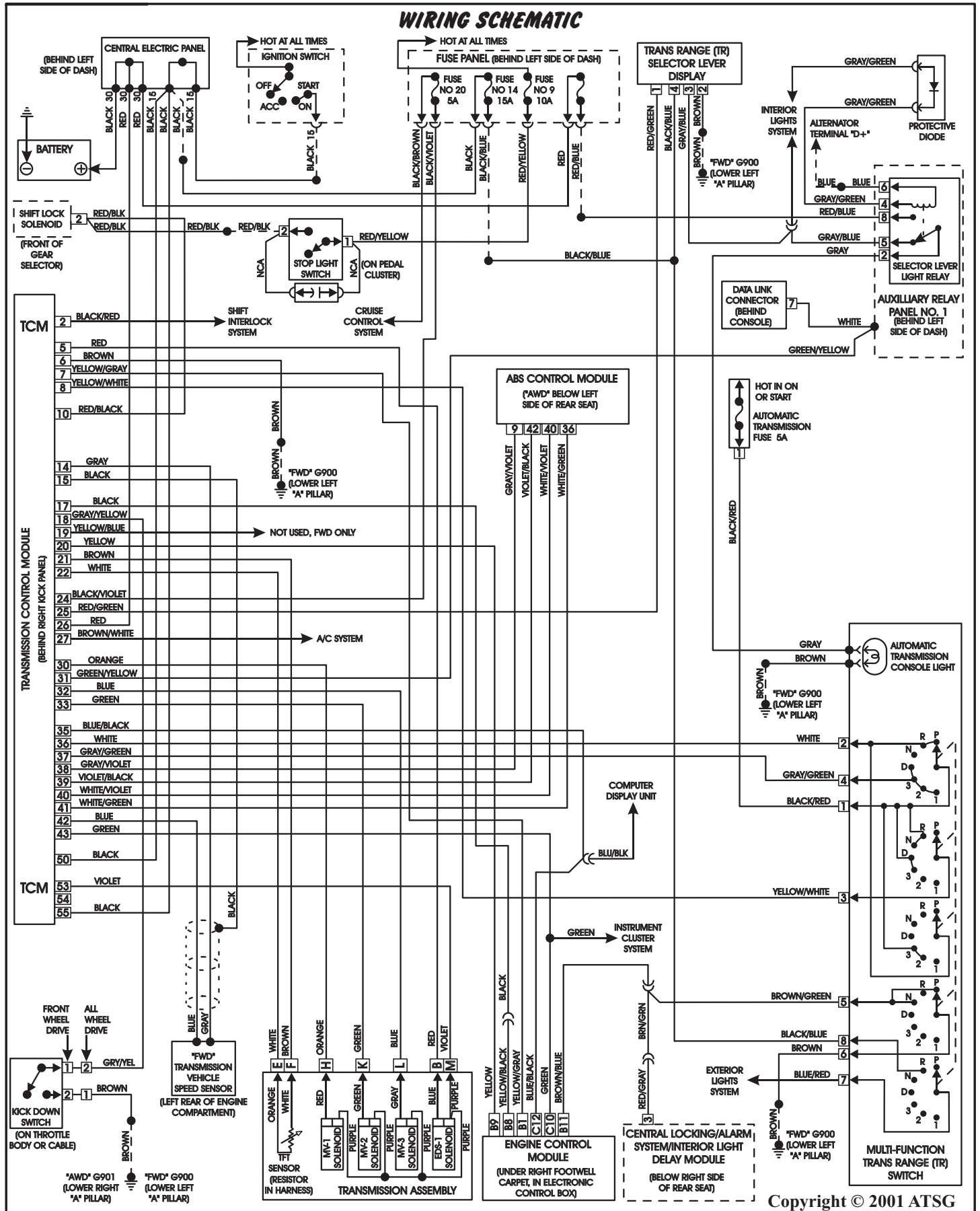

Figure 3

ZF-4HP-18FLE SOLENOID AND COMPONENT APPLICATION CHART

RANGE	MV-1 Sol.	MV-2 Sol.	MV-3 Sol.	EDS-1 Sol.	"A" Clutch	"B" Clutch	2-4 Band	"C" Clutch	"D" Clutch	"E" Clutch
Park/Neut		ON	ON	**						
Reverse		ON	*	**		ON			ON	
Drive-1st			ON	**	ON					
Drive-2nd	ON		ON	**	ON		ON	ON		
Drive-3rd	ON			**	ON			ON		ON
Drive-4th				**			ON	ON		ON
Manual-1st			ON	**	ON				ON	
"Failsafe" ***				Max.	ON		ON	ON		

* ON For Reverse Inhibit Feature.

** Pressure Regulating.

*** Electrical failure while in 4th gear, vehicle remains in 4th gear until engine is turned off. When vehicle is once again started, transaxle will be in "Failsafe" 2nd gear. Refer to Page 22 for complete explanation of Safety Mode Valve Operation.

SPECIAL NOTE:

Solenoid and Clutch nomenclature are ATSG interpretations, not Audi's nor ZF.

Copyright © 2001 ATSG

Figure 4

ZF-4HP-18FLA/E VALVE BODY COMPLETE

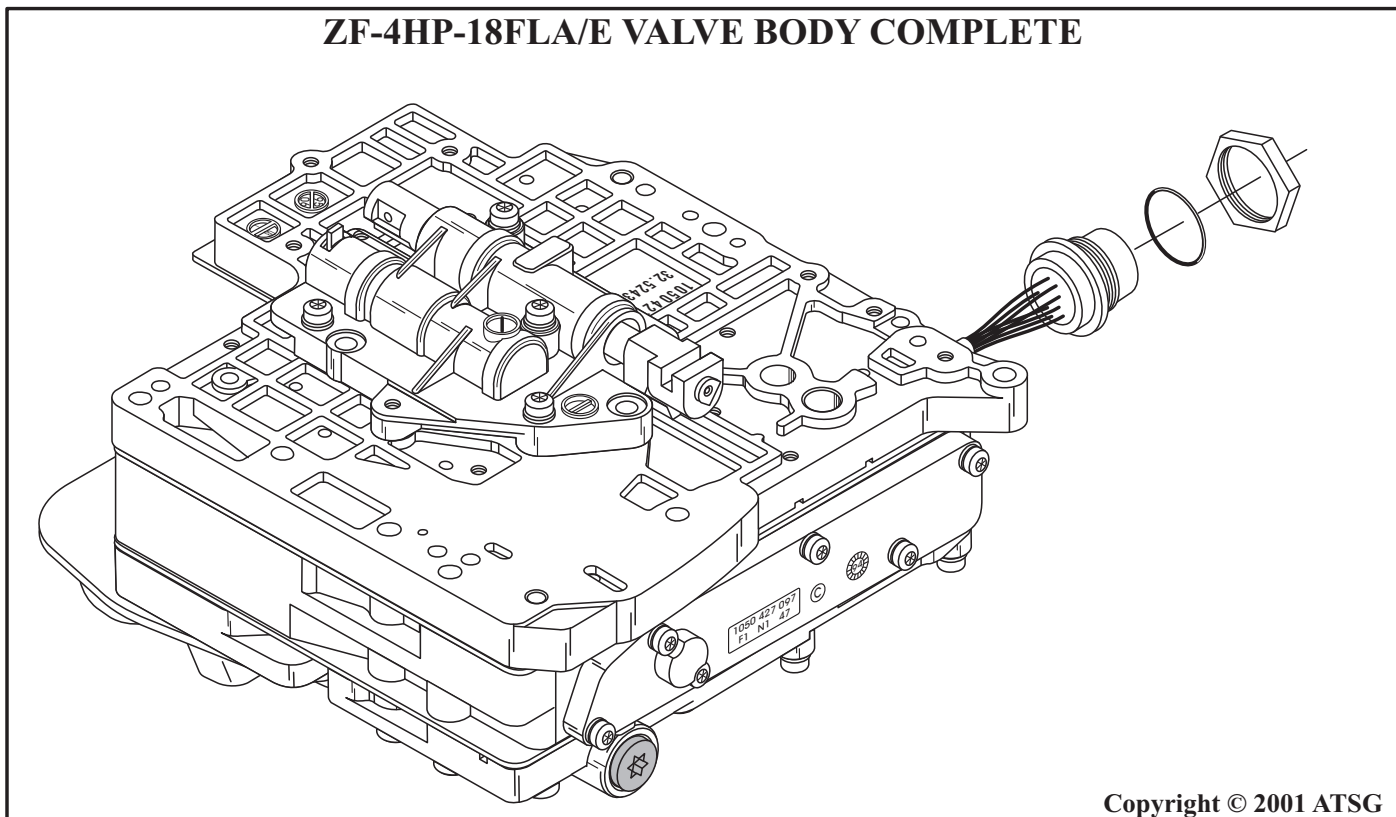

Copyright © 2001 ATSG

Figure 5

ZF-4HP-18FLA/E OIL FILTER AND FILTER TRANSFER PLATE

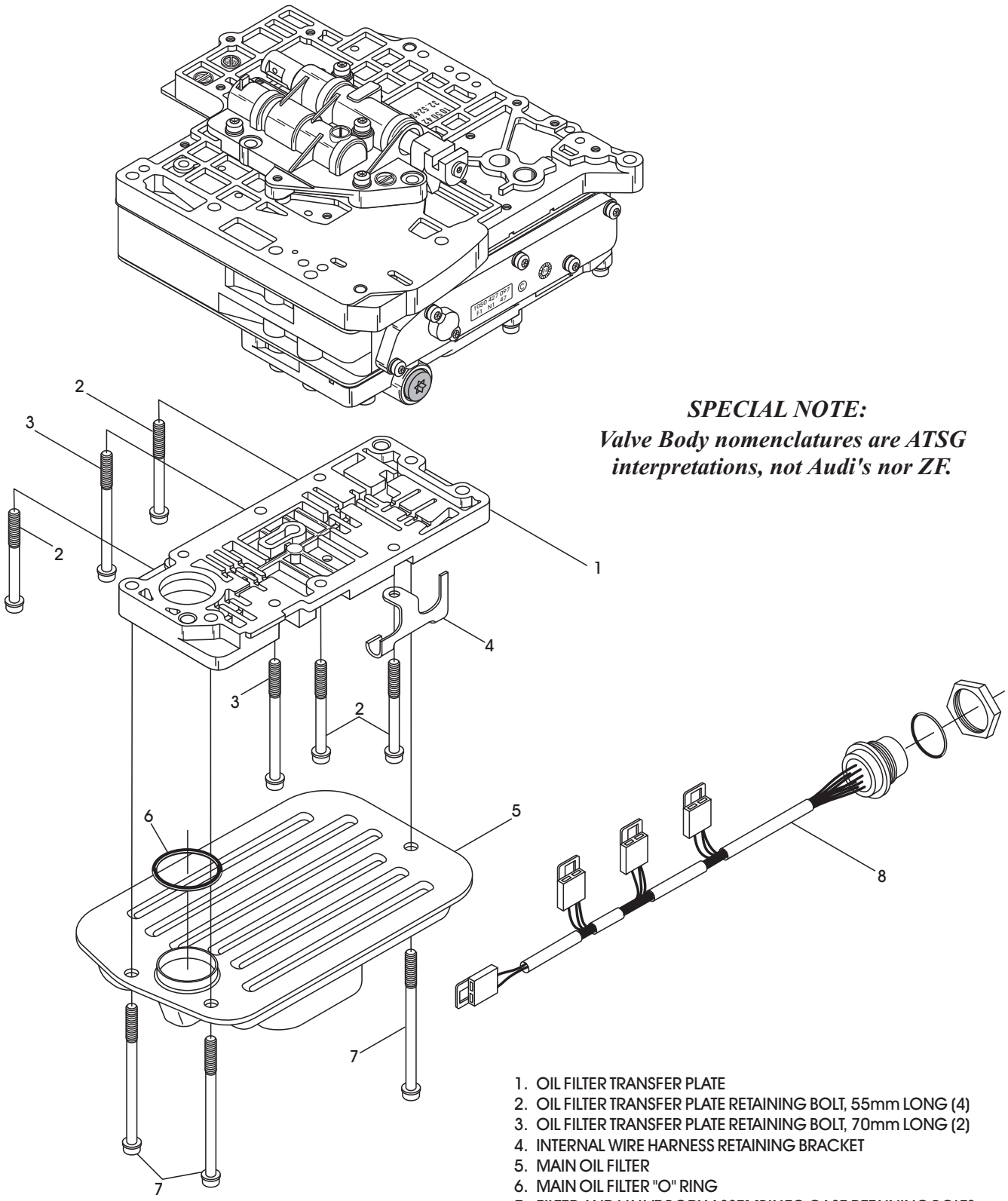

SPECIAL NOTE:
Valve Body nomenclatures are ATSG interpretations, not Audi's nor ZF.

- 1. OIL FILTER TRANSFER PLATE
- 2. OIL FILTER TRANSFER PLATE RETAINING BOLT, 55mm LONG (4)
- 3. OIL FILTER TRANSFER PLATE RETAINING BOLT, 70mm LONG (2)
- 4. INTERNAL WIRE HARNESS RETAINING BRACKET
- 5. MAIN OIL FILTER
- 6. MAIN OIL FILTER "O" RING
- 7. FILTER AND VALVE BODY ASSEMBLY TO CASE RETAINING BOLTS

Copyright © 2001 ATSG

Figure 6

ZF-4HP-18FLA/E MANUAL VALVE BODY

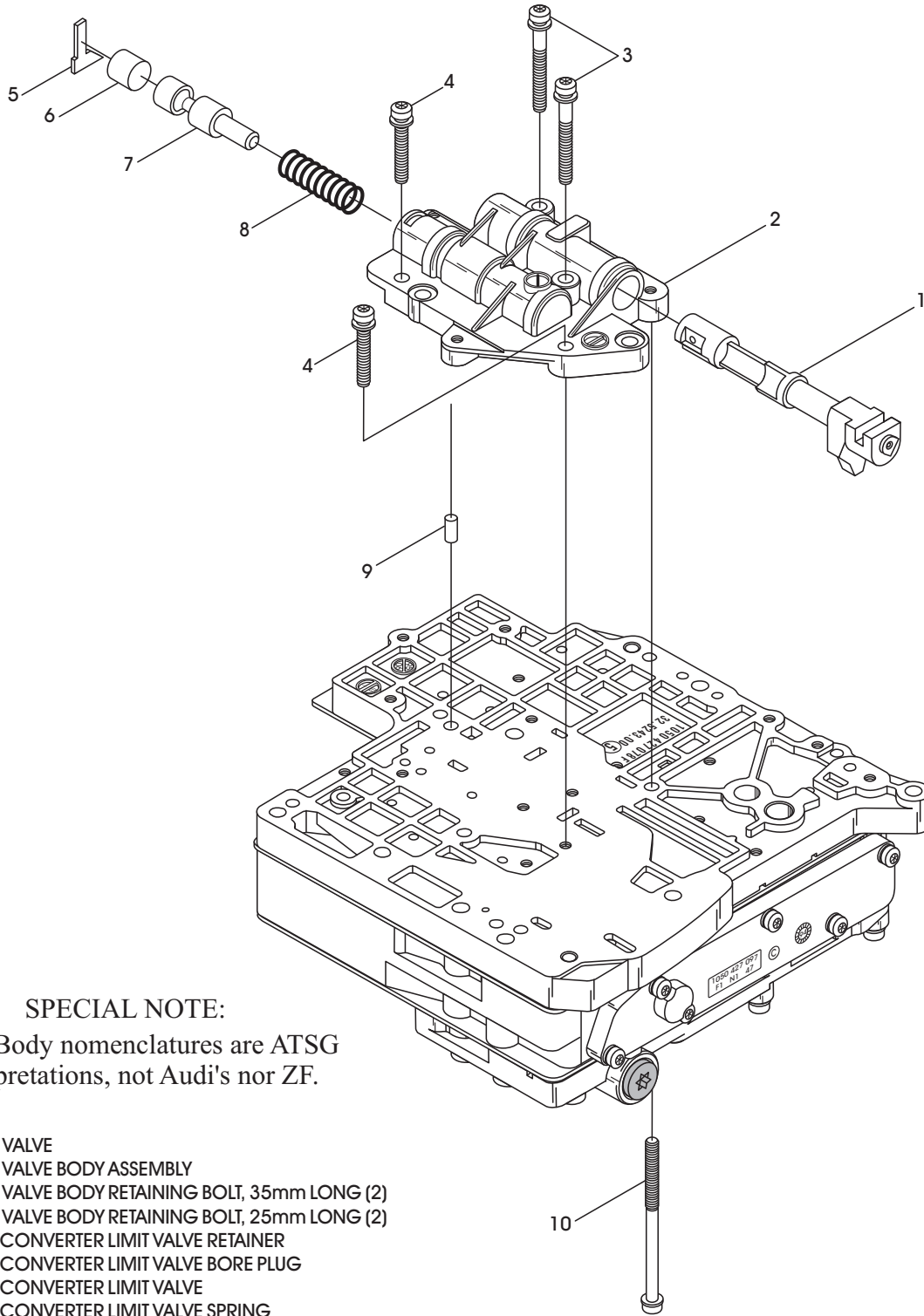

SPECIAL NOTE:

Valve Body nomenclatures are ATSG interpretations, not Audi's nor ZF.

1. MANUAL VALVE
2. MANUAL VALVE BODY ASSEMBLY
3. MANUAL VALVE BODY RETAINING BOLT, 35mm LONG (2)
4. MANUAL VALVE BODY RETAINING BOLT, 25mm LONG (2)
5. TORQUE CONVERTER LIMIT VALVE RETAINER
6. TORQUE CONVERTER LIMIT VALVE BORE PLUG
7. TORQUE CONVERTER LIMIT VALVE
8. TORQUE CONVERTER LIMIT VALVE SPRING
9. ALIGNMENT DOWEL PIN, .235" DIAMETER, .612" LONG
10. LOWER PLATE/MANUAL VALVE BODY BOLT, 65mm LONG (1)

Copyright © 2001 ATSG

Figure 7

ZF-4HP-18FLA/E SOLENOID VALVE BODY

SPECIAL NOTE:
Valve Body nomenclatures are ATSG interpretations, not Audi's nor ZF.

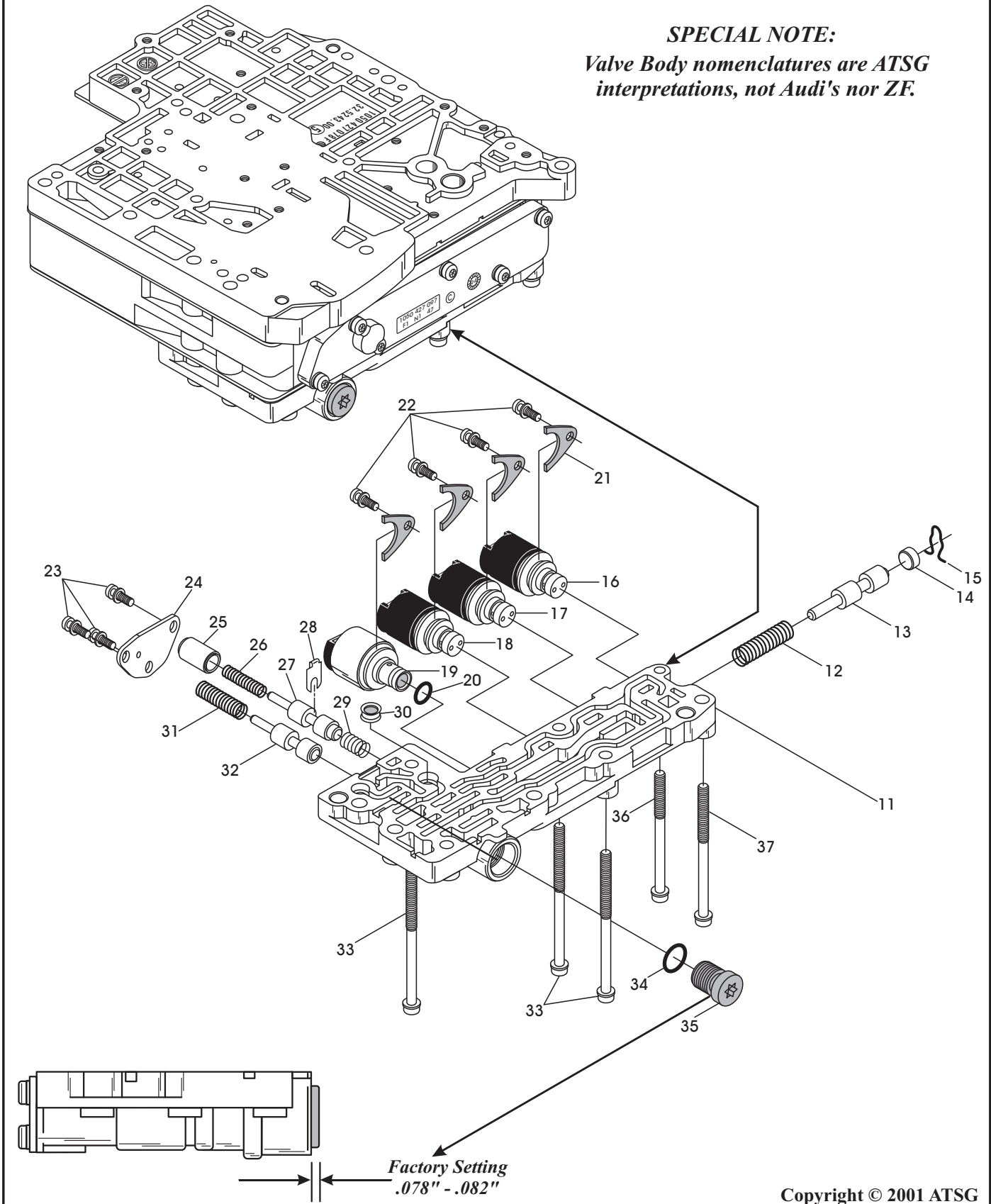

Figure 8



TECHNICIANS DIAGNOSTIC GUIDE BMW, AUDI, PORSCHE

11. SOLENOID VALVE BODY CASTING
12. PRESSURE REGULATOR VALVE SPRING, MV-1 THRU MV-3 SOLENOIDS
13. PRESSURE REGULATOR VALVE, MV-1 THRU MV-3 SOLENOIDS
14. PRESSURE REGULATOR VALVE BORE PLUG, MV-1 THRU MV-3 SOLENOIDS
15. PRESSURE REGULATOR VALVE RETAINING CLIP, MV-1 THRU MV-3 SOLENOIDS
16. MV-1 SOLENOID, OEM PART NUMBER 0501 313 500 (SHIFT CONTROL)
17. MV-2 SOLENOID, OEM PART NUMBER 0501 313 500 (SHIFT CONTROL)
18. MV-3 SOLENOID, OEM PART NUMBER 0501 313 500 (SHIFT CONTROL)
19. EDS-1 SOLENOID, OEM PART NUMBER 0501 311 843 (LINE PRESSURE)
20. EDS-1 SOLENOID "O" RING
21. SOLENOID RETAINING BRACKET (4 REQUIRED)
22. SOLENOID RETAINING BRACKET BOLT, 12mm LONG (4 REQUIRED)
23. RETAINING PLATE BOLT, 12mm LONG (3 REQUIRED)
24. SOLENOID BODY RETAINING PLATE
25. MODULATING VALVE PLUNGER
26. MODULATING VALVE SPRING
27. MODULATING VALVE
28. MODULATING VALVE RETAINING CLIP
29. MODULATING VALVE BALANCE SPRING
30. EDS-1 SOLENOID SCREEN
31. PRESSURE REGULATOR VALVE SPRING, FOR EDS-1 SOLENOID
32. PRESSURE REGULATOR VALVE, FOR EDS-1 SOLENOID
33. SOLENOID VALVE BODY RETAINING BOLT, 70mm LONG (3 REQUIRED)
34. MODULATING VALVE ADJUSTING SCREW "O" RING
35. MODULATING VALVE ADJUSTING SCREW
36. SOLENOID VALVE BODY RETAINING BOLT, 60mm LONG (1 REQUIRED)
37. SOLENOID VALVE BODY RETAINING BOLT, 65mm LONG (1 REQUIRED)

SPECIAL NOTE:
Valve Body nomenclatures are ATSG
interpretations, not Audi's nor ZF.

Copyright © 2001 ATSG

Figure 8 LEGEND

ZF-4HP-18FLA/E COMPONENT ASSEMBLY

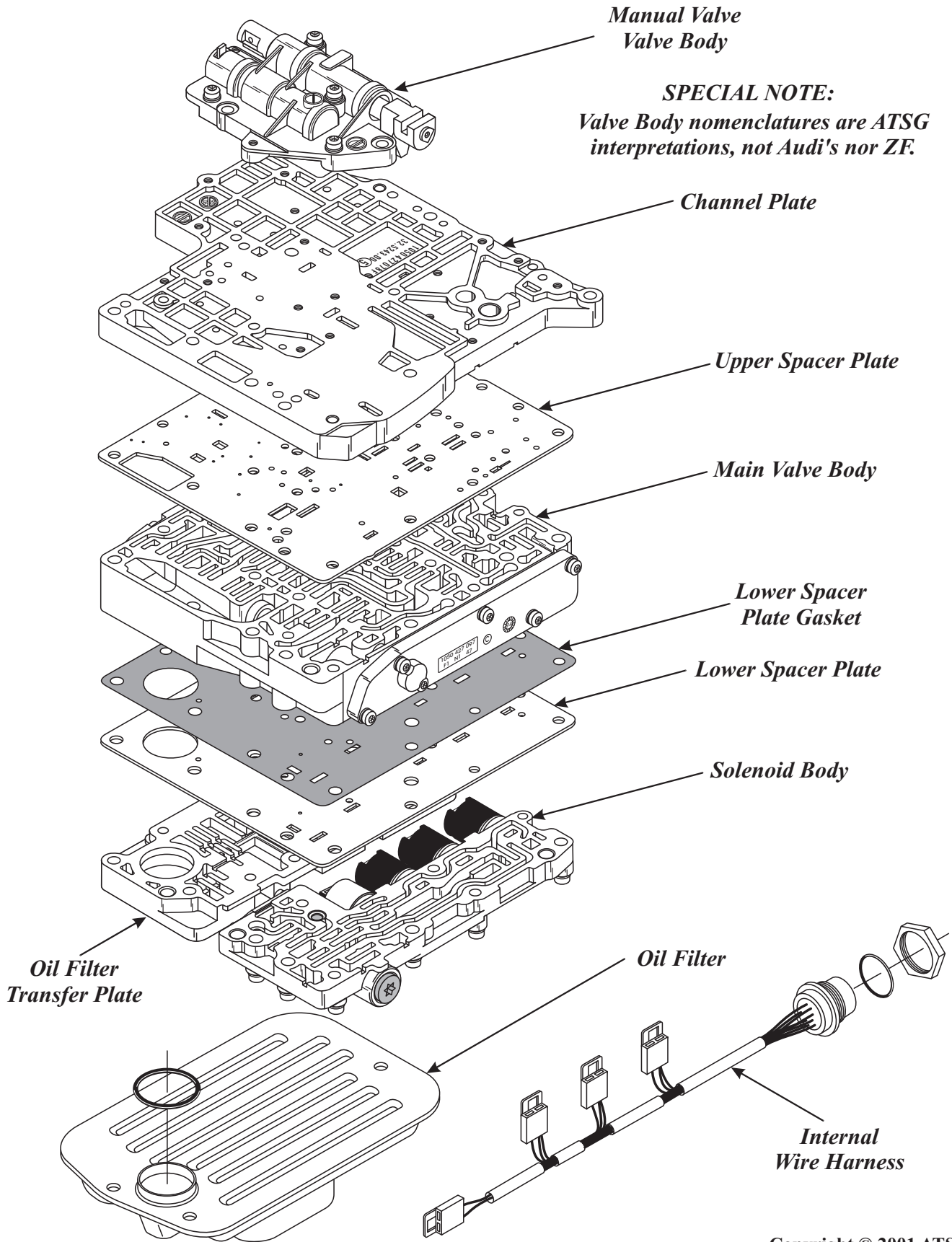

Copyright © 2001 ATSG

Figure 9

ZF-4HP-18FLA/E MAIN VALVE BODY "REAR SIDE" DETAIL

*Legend Found
On Next Page.*

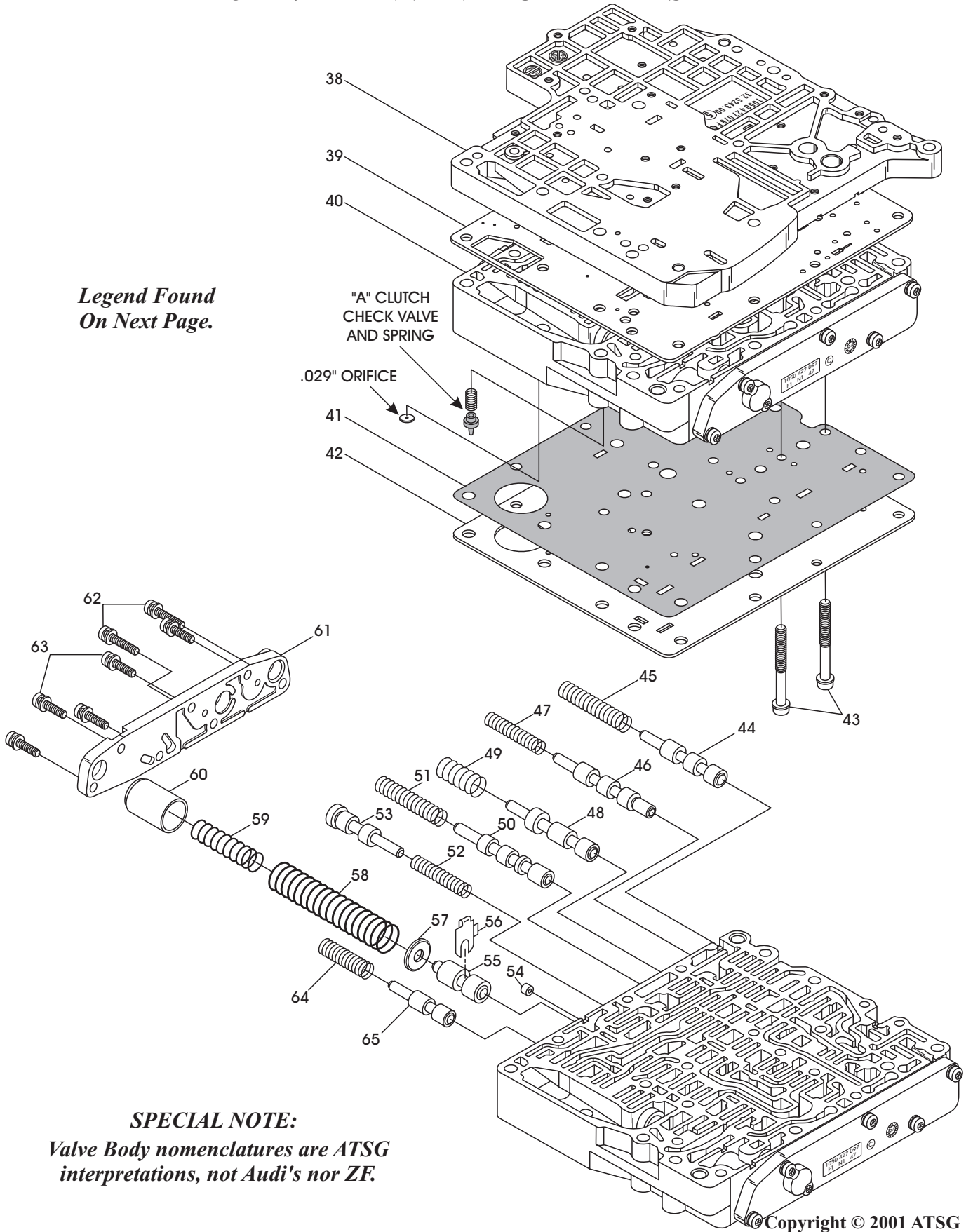

SPECIAL NOTE:
*Valve Body nomenclatures are ATSG
 interpretations, not Audi's nor ZF.*

Copyright © 2001 ATSG

Figure 10

ZF-4HP-18FLA/E MAIN VALVE BODY "FRONT SIDE" DETAIL

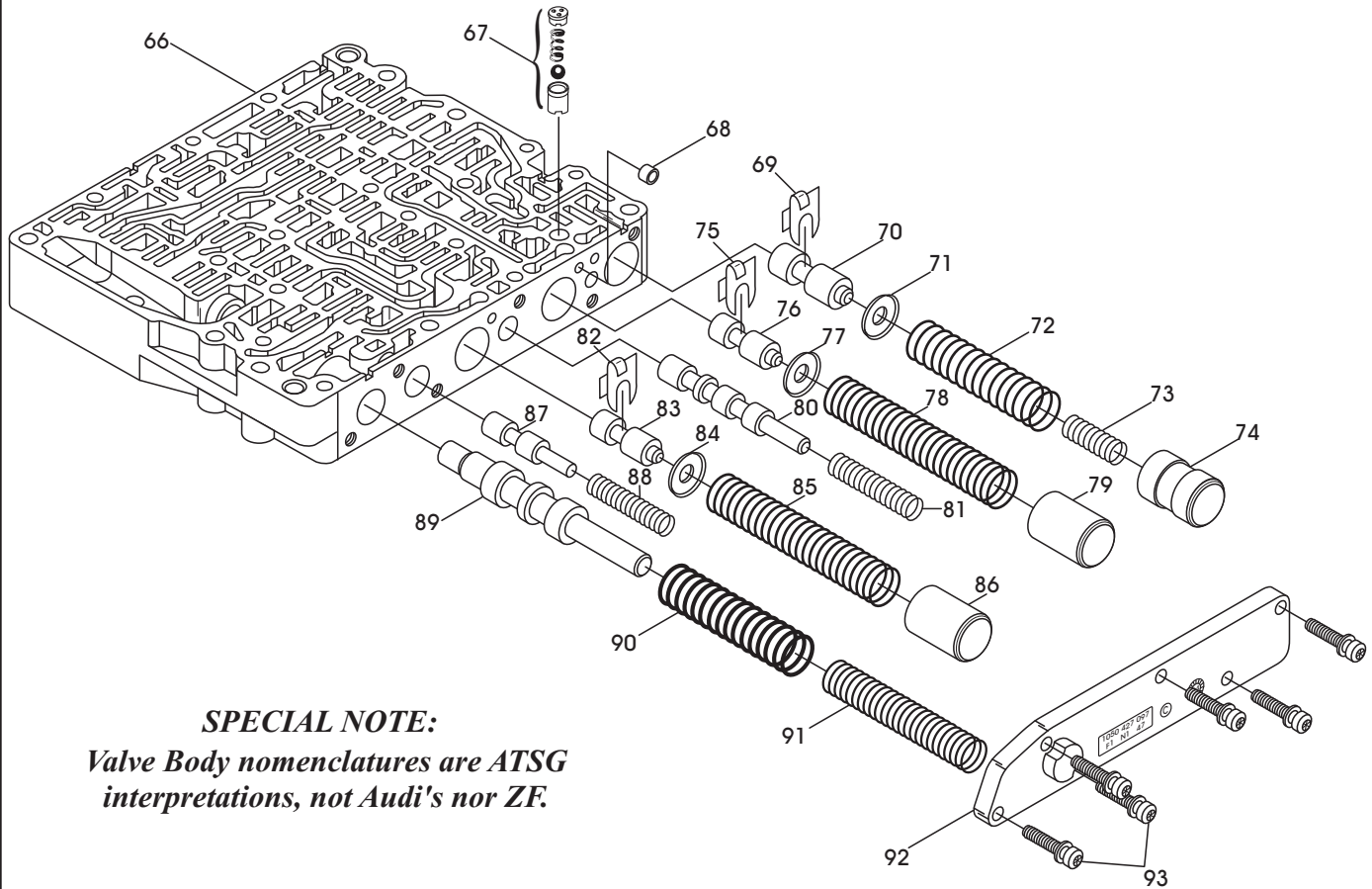

SPECIAL NOTE:
Valve Body nomenclatures are ATSG interpretations, not Audi's nor ZF.

FIGURE 10 LEGEND

- 38. CHANNEL PLATE ASSEMBLY
- 39. UPPER SPACER PLATE
- 40. MAIN VALVE BODY ASSEMBLY
- 41. MAIN VALVE BODY TO LOWER SPACER PLATE GASKET
- 42. LOWER SPACER PLATE
- 43. SPACER PLATE TO CHANNEL PLATE BOLT, 50mm LONG (2)
- 44. SHIFT VALVE NUMBER ONE
- 45. SHIFT VALVE NUMBER ONE SPRING
- 46. SHIFT VALVE NUMBER TWO
- 47. SHIFT VALVE NUMBER TWO SPRING
- 48. SAFETY MODE VALVE
- 49. SAFETY MODE VALVE SPRING
- 50. SHIFT VALVE NUMBER THREE
- 51. SHIFT VALVE NUMBER THREE SPRING
- 52. 3-4 TRACTION VALVE SPRING
- 53. 3-4 TRACTION VALVE
- 54. .060" ORIFICED CUP PLUG IN VALVE BODY CASTING
- 55. "A" CLUTCH ACCUMULATOR VALVE
- 56. "A" CLUTCH ACCUMULATOR VALVE RETAINER
- 57. "A" CLUTCH ACCUMULATOR VALVE SPRING SEAT
- 58. "A" CLUTCH ACCUMULATOR OUTER SPRING
- 59. "A" CLUTCH ACCUMULATOR INNER SPRING
- 60. "A" CLUTCH ACCUMULATOR PLUNGER
- 61. REAR SIDE VALVE RETAINING COVER
- 62. REAR SIDE COVER RETAINING SCREWS, 22mm LONG (2)
- 63. REAR SIDE COVER RETAINING SCREWS, 18mm LONG (5)
- 64. "C" CLUTCH TRACTION VALVE SPRING
- 65. "C" CLUTCH TRACTION VALVE

FIGURE 11 LEGEND

- 66. MAIN VALVE BODY CASTING
- 67. "D" CLUTCH ONE-WAY CHECK VALVE, (.020" ORIFICE)
- 68. .070" ORIFICED CUP PLUG IN VALVE BODY CASTING
- 69. "D" CLUTCH ACCUMULATOR VALVE RETAINER
- 70. "D" CLUTCH ACCUMULATOR VALVE
- 71. "D" CLUTCH ACCUMULATOR VALVE SPRING SEAT
- 72. "D" CLUTCH ACCUMULATOR OUTER SPRING
- 73. "D" CLUTCH ACCUMULATOR INNER SPRING
- 74. "D" CLUTCH ACCUMULATOR PLUNGER
- 75. "C" CLUTCH ACCUMULATOR VALVE RETAINER
- 76. "C" CLUTCH ACCUMULATOR VALVE
- 77. "C" CLUTCH ACCUMULATOR VALVE SPRING SEAT
- 78. "C" CLUTCH ACCUMULATOR SPRING
- 79. "C" CLUTCH ACCUMULATOR PLUNGER
- 80. 1ST AND REVERSE VALVE
- 81. 1ST AND REVERSE VALVE SPRING
- 82. "E" CLUTCH ACCUMULATOR VALVE RETAINER
- 83. "E" CLUTCH ACCUMULATOR VALVE
- 84. "E" CLUTCH ACCUMULATOR VALVE SPRING SEAT
- 85. "E" CLUTCH ACCUMULATOR SPRING
- 86. "E" CLUTCH ACCUMULATOR PLUNGER
- 87. 4-3 TRACTION VALVE
- 88. 4-3 TRACTION VALVE SPRING
- 89. MAIN LINE PRESSURE REGULATOR VALVE
- 90. MAIN LINE PRESSURE REGULATOR VALVE OUTER SPRING
- 91. MAIN LINE PRESSURE REGULATOR VALVE INNER SPRING
- 92. FRONT SIDE VALVE RETAINING COVER
- 93. FRONT SIDE COVER RETAINING SCREWS, 18mm LONG (6)

Figure 11



TECHNICIANS DIAGNOSTIC GUIDE

BMW, AUDI, PORSCHE

ZF 4HP-18FLA/E SPRING SPECIFICATIONS

<i>Manual Valve Body</i>	<i>Solenoid Valve Body</i>	<i>Main Valve Body</i>	
		<i>"Back Side"</i>	<i>"Front Side"</i>
SPRING ILLUSTRATION NO. 8 FREE LENGTH = 1.618" SPRING DIAMETER = .495" WIRE DIAMETER = .062"	SPRING ILLUSTRATION NO. 12 FREE LENGTH = 1.688" SPRING DIAMETER = .375" WIRE DIAMETER = .042"	SPRING ILLUSTRATION NO. 45: FREE LENGTH = 1.865" SPRING DIAMETER = .382" WIRE DIAMETER = .035"	SPRING ILLUSTRATION NO. 72: FREE LENGTH = 2.860" SPRING DIAMETER = .612" WIRE DIAMETER = .048"
	SPRING ILLUSTRATION NO. 26 FREE LENGTH = 1.475" SPRING DIAMETER = .320" WIRE DIAMETER = .042"	SPRING ILLUSTRATION NO. 47: FREE LENGTH = 1.595" SPRING DIAMETER = .365" WIRE DIAMETER = .031"	SPRING ILLUSTRATION NO. 73: FREE LENGTH = 1.589" SPRING DIAMETER = .429" WIRE DIAMETER = .035"
	SPRING ILLUSTRATION NO. 29 FREE LENGTH = .760" SPRING DIAMETER = .370" WIRE DIAMETER = .028"	SPRING ILLUSTRATION NO. 49: FREE LENGTH = 1.194" SPRING DIAMETER = .443" WIRE DIAMETER = .031"	SPRING ILLUSTRATION NO. 78: FREE LENGTH = 3.530" SPRING DIAMETER = .575" WIRE DIAMETER = .039"
	SPRING ILLUSTRATION NO. 31 FREE LENGTH = 1.530" SPRING DIAMETER = .340" WIRE DIAMETER = .042"	SPRING ILLUSTRATION NO. 51: FREE LENGTH = 1.832" SPRING DIAMETER = .364" WIRE DIAMETER = .031"	SPRING ILLUSTRATION NO. 81: FREE LENGTH = 1.815" SPRING DIAMETER = .365" WIRE DIAMETER = .031"
		SPRING ILLUSTRATION NO. 52: FREE LENGTH = 1.289" SPRING DIAMETER = .298" WIRE DIAMETER = .027"	SPRING ILLUSTRATION NO. 85: FREE LENGTH = 3.530" SPRING DIAMETER = .575" WIRE DIAMETER = .039"
		SPRING ILLUSTRATION NO. 58: FREE LENGTH = 3.216" SPRING DIAMETER = .590" WIRE DIAMETER = .042"	SPRING ILLUSTRATION NO. 88: FREE LENGTH = 1.712" SPRING DIAMETER = .361" WIRE DIAMETER = .031"
		SPRING ILLUSTRATION NO. 59: FREE LENGTH = 1.592" SPRING DIAMETER = .432" WIRE DIAMETER = .035"	SPRING ILLUSTRATION NO. 90: FREE LENGTH = 2.909" SPRING DIAMETER = .605" WIRE DIAMETER = .066"
		SPRING ILLUSTRATION NO. 64: FREE LENGTH = 1.514" SPRING DIAMETER = .363" WIRE DIAMETER = .038"	SPRING ILLUSTRATION NO. 91: FREE LENGTH = 3.612" SPRING DIAMETER = .445" WIRE DIAMETER = .042"

Special Note:

The spring dimensions listed above were "Observations" from only one valve body, and may vary from one model to another.

Figure 12

ZF-4HP-18FLE/FLA
SOLENOID BODY RETAINER AND SCREEN LOCATIONS

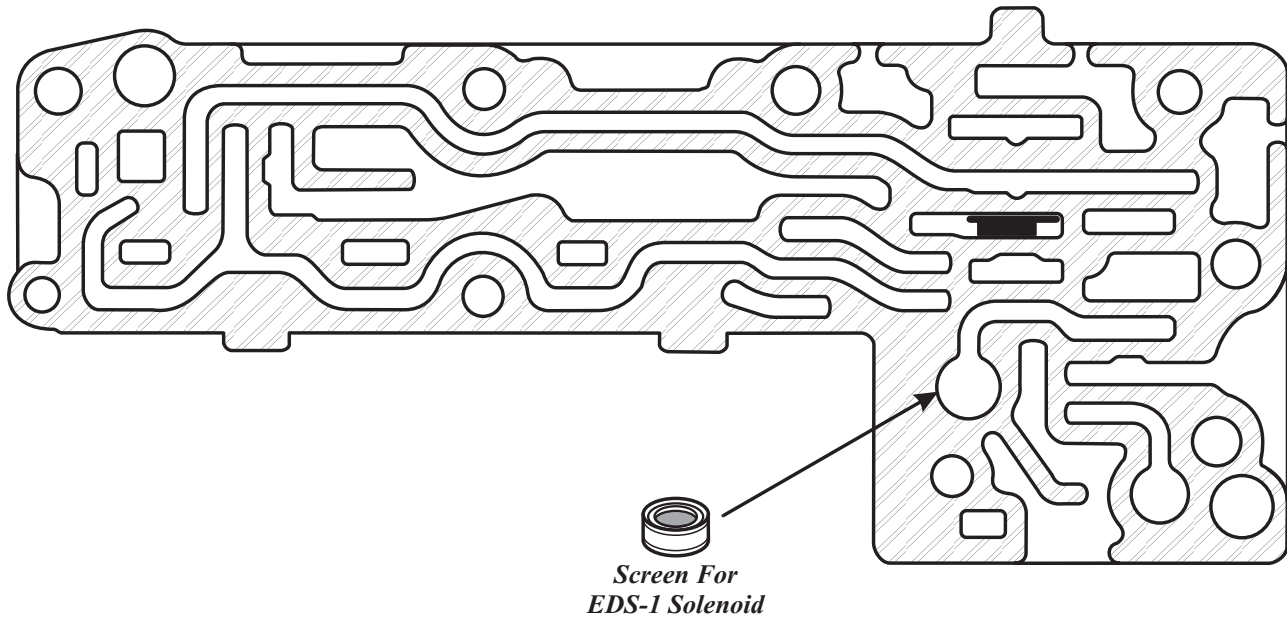

Copyright © 2001 ATSG

Figure 13

ZF-4HP-18FLE/FLA
MANUAL VALVE BODY RETAINER LOCATIONS

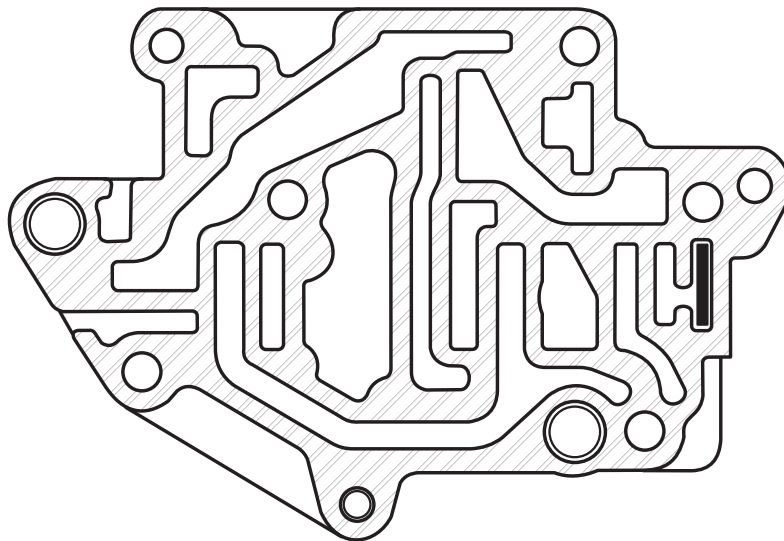

Copyright © 2001 ATSG

Figure 14

ZF-4HP-18FLE/FLA
MAIN VALVE BODY BODY "TOP SIDE" RETAINER AND ORIFICE LOCATIONS

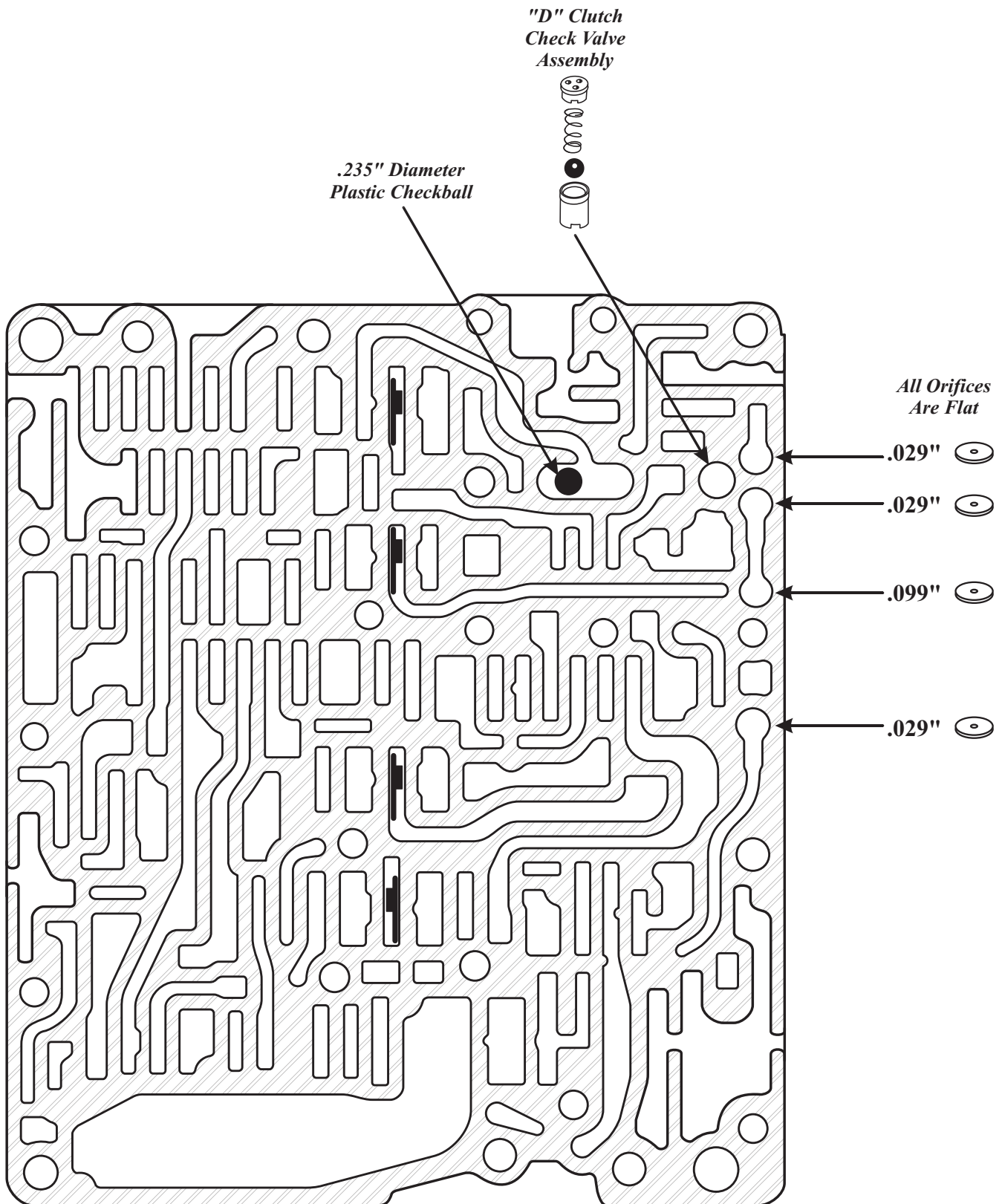

Copyright © 2001 ATSG

Figure 15

ZF-4HP-18FLE/FLA

MAIN VALVE BODY BODY "BOTTOM SIDE" VALVE AND ORIFICE LOCATIONS

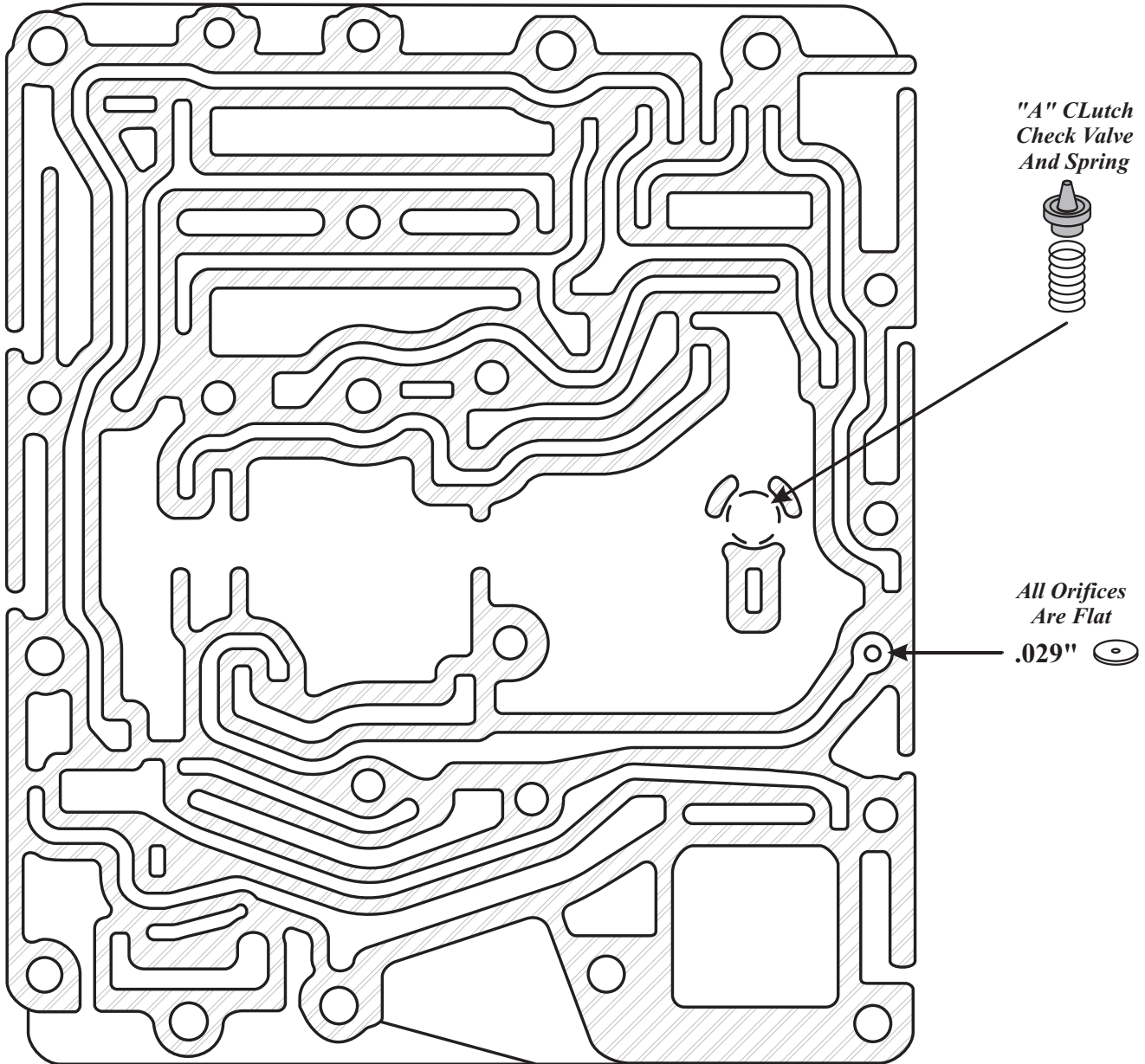

Copyright © 2001 ATSG

Figure 16

ZF-4HP-18FLE/FLA
CHANNEL PLATE ORIFICE LOCATIONS

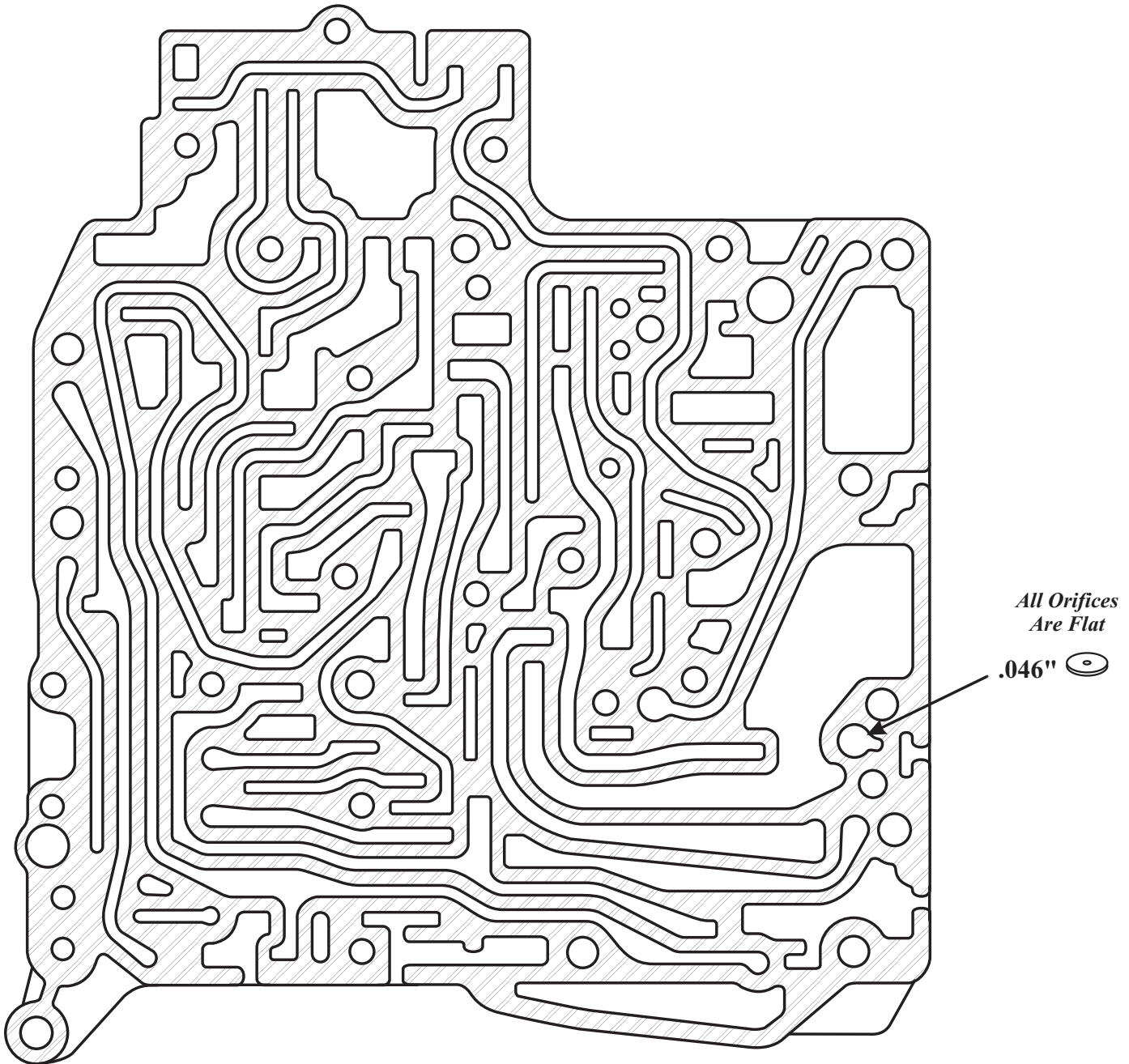

Copyright © 2001 ATSG

Figure 17

ZF-4HP-18FLE/FLA PRESSURE TAP LOCATIONS

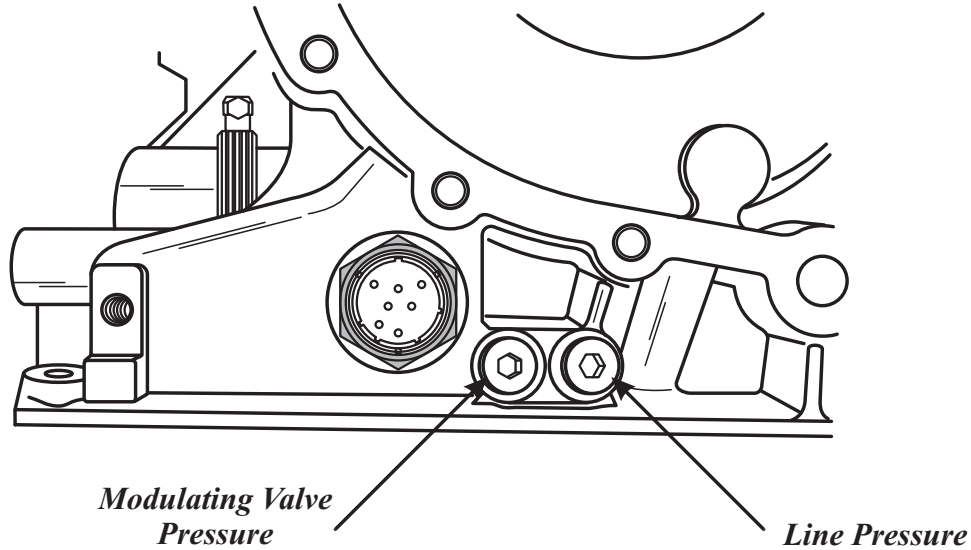

SAFETY MODE VALVE OPERATION

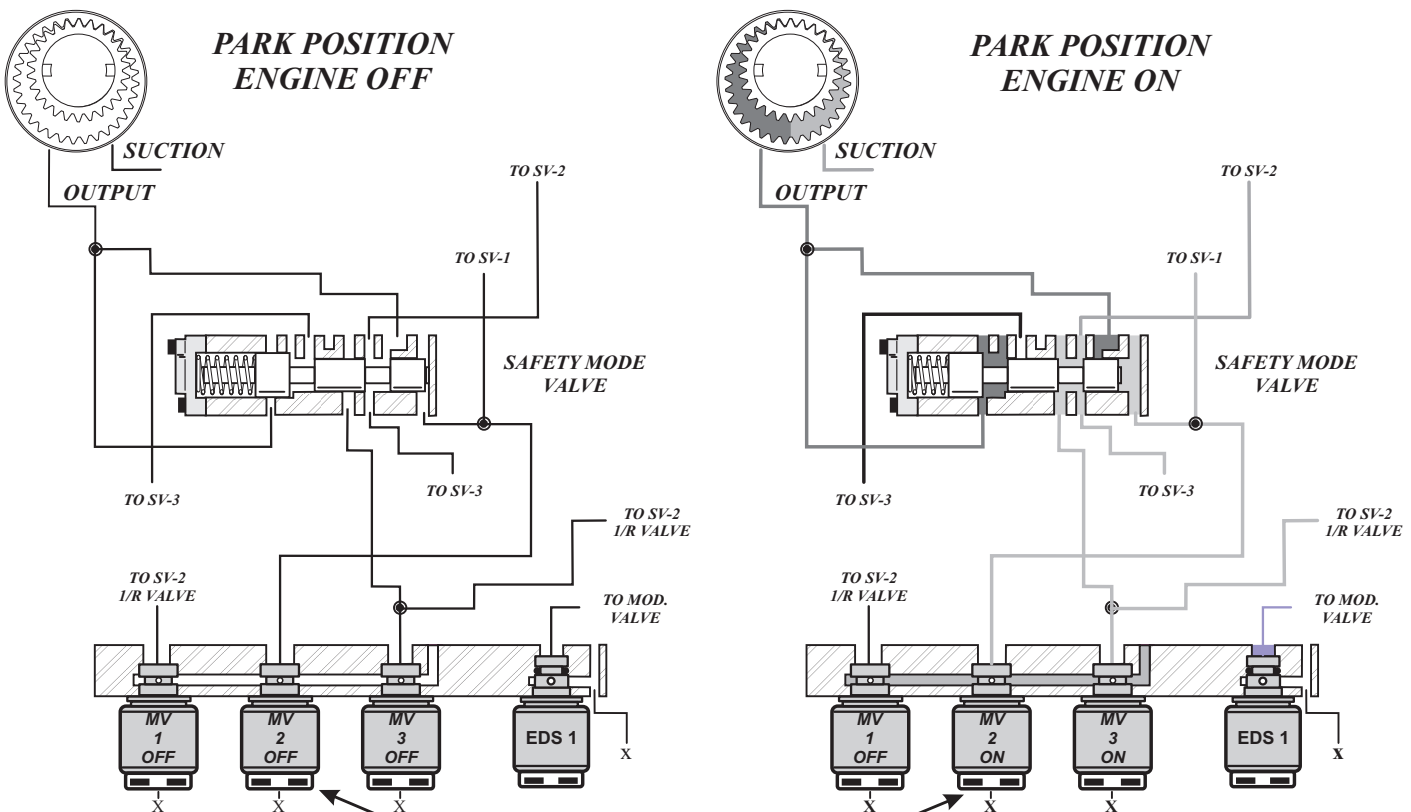

MV-2 IS TURNED "ON", ONLY TO STROKE THE SAFETY MODE VALVE. PUMP PRESSURE WILL KEEP THE SAFETY MODE VALVE STROKED, AS LONG AS THE ENGINE IS RUNNING

Copyright © 2001 ATSG

Figure 18

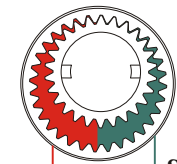

TO CONVERTER (LUBRICATION)

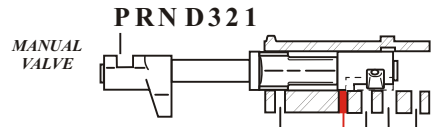

**COLOR HYDRAULIC SCHEMATIC
(FOLD OUT) ON THIS PAGE.**

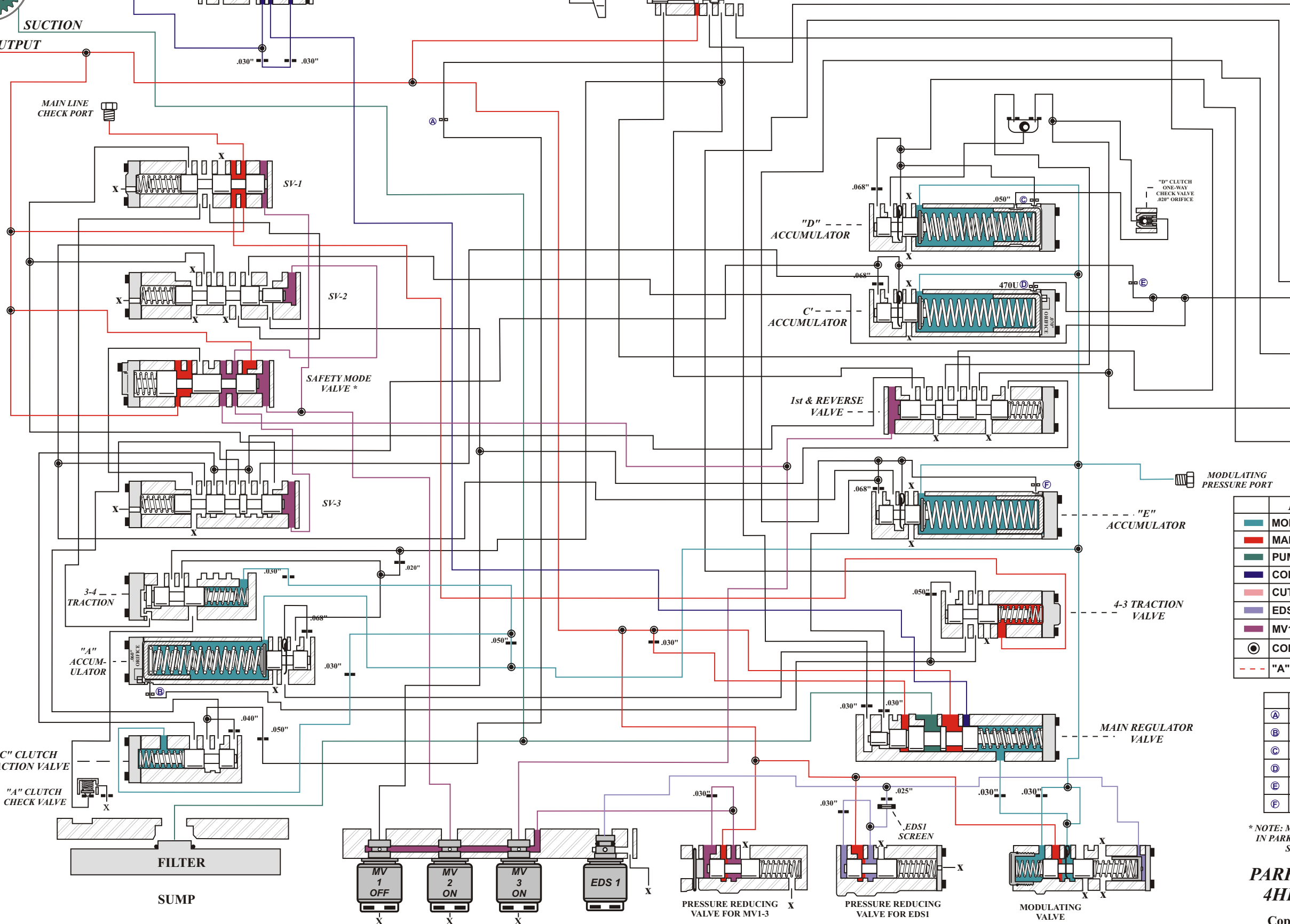

- "C" CLUTCH
- "B" CLUTCH
- C' BAND 2-4 BAND
- "A" CLUTCH
- "E" CLUTCH
- "D" CLUTCH

LEGEND	
█	MODULATING PRESSURE
█	MAIN LINE PRESSURE
█	PUMP SUCTION
█	CONVERTER PRESSURE
█	CUTBACK PRESSURE
█	EDS1 PRESSURE
█	MV1-3 REDUCING PRESSURE
⊙	CONNECTED CIRCUIT
- - -	"A" CLUTCH PREFILL

ORIFICE I.D.	
Ⓐ	.046"
Ⓑ	.029"
Ⓒ	.029"
Ⓓ	.029"
Ⓔ	.099"
Ⓕ	.029"

* NOTE: MV2 IS INITIALLY ENERGIZED IN PARK/NEUTRAL TO STROKE THE SAFETY MODE VALVE

**PARK OR NEUTRAL
4HP-18 FLE/FLA**

Copyright © 2001 ATSG

**ZF 4HP-22/24 SERIES
DIAGNOSTIC INFORMATION**

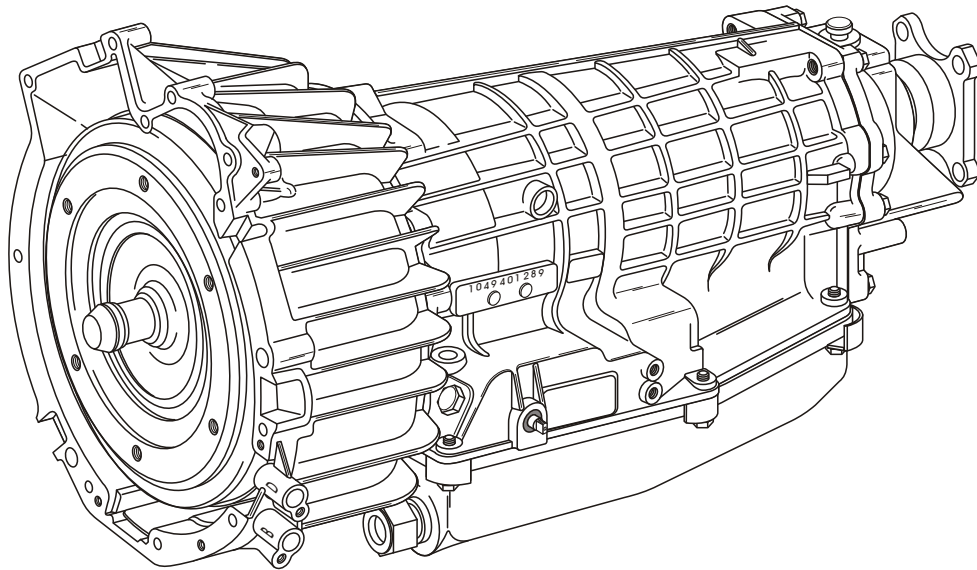

The Electronic Control system was first introduced in 1986 and was incorporated into the totally hydraulic 4HP-22 unit produced by ZF. It combines the hydraulic control of forward and reverse gear engagement, with electronic control for automatic upshifts from 1st thru 4th and automatic downshifts from 4th thru 1st gears. Three different versions of valve bodies have been used on BMW vehicles, with minor differences between them

The 1st version, *designated Early "E-7"*, has **5 solenoids** on the valve body, was introduced in 1986 and used up thru 1989. This version includes a solenoid for reverse lockout.

The 2nd version, *designated Late "E-7"*, has **5 solenoids** on the valve body, was introduced in 1988 and used up thru Mid-1989. This version includes a solenoid for reverse lockout.

The 3rd version, *designated "E-9"*, has **4 solenoids** on the valve body, was introduced in Mid-1989 and used up thru 1994. This version uses a shift solenoid for the reverse lockout function.

MODEL YEAR USAGE CHART

<i>Valve Body Models</i>	<i>Model Year</i>								
	86	87	88	89	90	91	92	93	94
<i>1st Version, Early "E-7", 5 Solenoid</i>									
<i>2nd Version, Late "E-7", 5 Solenoid</i>									
<i>3rd Version, "E-9", 4 Solenoid</i>									

Copyright © 2003 ATSG

Figure 19



TECHNICIANS DIAGNOSTIC GUIDE BMW, AUDI, PORSCHE

FOR ZF 4HP-22/24 SERIES VEHICLES

Refer to Figure 19 for model year usage of the "E7", 5 Solenoid and "E9", 4 Solenoid valve bodies.

Refer to Figure 20 for internal component application chart for all models.

Refer to Figure 21 for shift quadrant and mode switch differences between the different models.

FOR MODEL "E7", "5 SOLENOID" VALVE BODY

Refer to Figure 22 for identification, location and function of the 5 solenoids, along with the shift solenoid firing order for the "E7" 5 solenoid models.

Refer to Figure 23 for internal wire schematic and case connector terminal identification, along with a resistance chart to check the internal electronic components.

Refer to Figure 24 for individual solenoid operation.

Refer to Figure 25 for valve body assembly exploded view.

Refer to Figure 26 for Lower Front Valve Body exploded view, with valve identification, and individual spring specifications, as observed in a used valve body.

Refer to Figure 27 for Lower Rear Valve Body exploded view, with valve identification, and individual spring specifications, as observed in a used valve body.

Refer to Figure 28 for MV-1 and MV-2 Shift Solenoid Body exploded view, with valve identification, and spring specifications, as observed in a used valve body.

Refer to Figure 29 for Pressure Control Solenoid Body exploded view, with solenoid identifications.

Refer to Figure 30 for Reverse Lockout Solenoid Body exploded view, with valve identifications, and spring specifications, as observed in a used valve body.

Refer to Figures 31, 32, 33, 34 for retainer, checkball, orifice and check valve and spring locations.

FOR MODEL "E9", "4 SOLENOID" VALVE BODY REFER TO PAGE 43 IN THIS MANUAL

COMPONENT APPLICATION CHART FOR ZF 4HP-22/24 SERIES

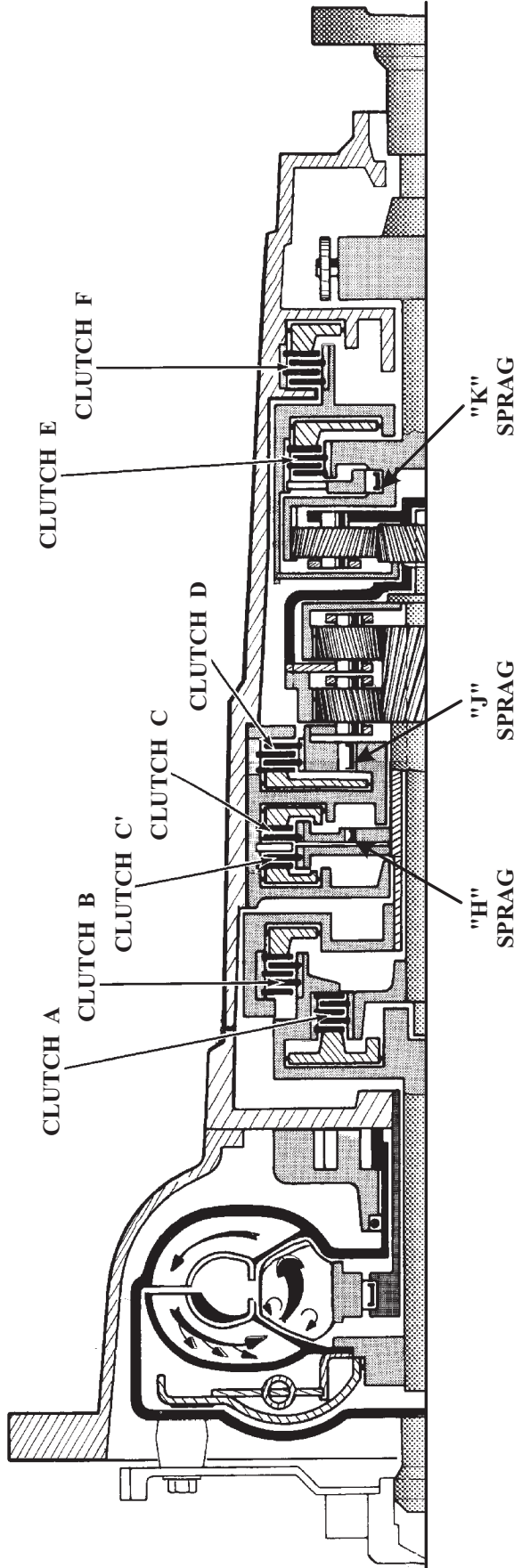

RANGE	"A" Clutch	"B" Clutch	"C" Clutch	"C" Clutch	"D" Clutch	"E" Clutch	"F" Clutch	"H" Sprag	"J" Sprag	"K" Sprag
Park										
Reverse		ON			ON	ON				Hold
Neutral										
"D"-1st	ON					ON			Hold	Hold
"D"-2nd	ON					ON		Hold		Hold
"D"-3rd	ON	ON				ON				Hold
"D"-4th	ON	ON	ON				ON			
"3"	Same as above, Automatic Shift 1st thru 3rd, 4th gear is inhibited.									
"2"	Same as above, Automatic Shift 1st thru 2nd, 3rd and 4th gear are inhibited.									
"1"	Same as above, except "D" Clutch is applied for engine braking									

Figure 20

SHIFT QUADRANTS FOR ZF 4HP-22/24 SERIES

Early "E-7" Models Only (5 Solenoid)

- (P)** = Parking Pawl Engaged
- (R)** = Reverse Gear
- (N)** = Neutral
- (D)** = Automatic Shifts 1st thru 4th Gears
- (3)** = Automatic Shifts 1st thru 3rd Gears.
4th Gear is locked out.
- (2)** = Automatic Shifts 1st thru 2nd Gears.
3rd and 4th Gear is locked out.
- (1)** = 1st Gear Only.
2nd, 3rd and 4th Gear is locked out.

Mode Switch Description

A *rotary* switch with three fixed positions and an indicator light in the instrument cluster for the 3-2-1 (M) mode when selected

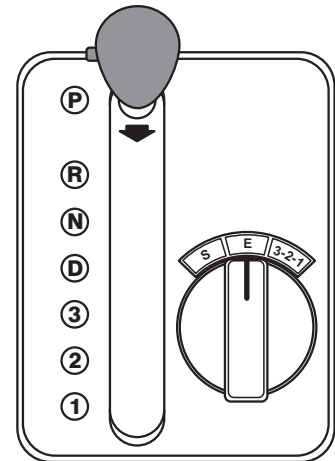

Late "E-7" Models Only (5 Solenoid)

- (P)** = Parking Pawl Engaged
- (R)** = Reverse Gear
- (N)** = Neutral
- (D)** = Automatic Shifts 1st thru 4th Gears
- (3)** = Automatic Shifts 1st thru 3rd Gears.
4th Gear is locked out.
- (2)** = Automatic Shifts 1st thru 2nd Gears.
3rd and 4th Gear is locked out.
- (1)** = 1st Gear Only.
2nd, 3rd and 4th Gear is locked out.

Mode Switch Description

A *three* position slide switch with Digital display of the three individual positions in instrument cluster (E-S-M). The switch is a momentary contact and spring loaded to a neutral position.

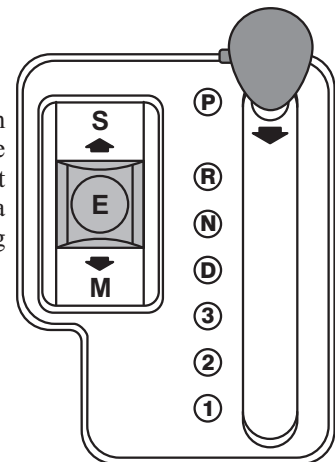

"E-9" Models Only (4 Solenoid)

- (P)** = Parking Pawl Engaged
- (R)** = Reverse Gear
- (N)** = Neutral
- (D)** = Automatic Shifts 1st thru 4th Gears
- (3)** = Automatic Shifts 1st thru 3rd Gears.
4th Gear is locked out.
- (2)** = Automatic Shifts 1st thru 2nd Gears.
3rd and 4th Gear is locked out.
- (1)** = 1st Gear Only.
2nd, 3rd and 4th Gear is locked out.

Mode Switch Description

A *two* position slide switch for the "A" mode (Economy and "M" mode (Manual). The Sport mode is selected with the range selector in position 3, 2, or 1 and "A" mode selected. The switch is a momentary contact and spring loaded to a neutral position.

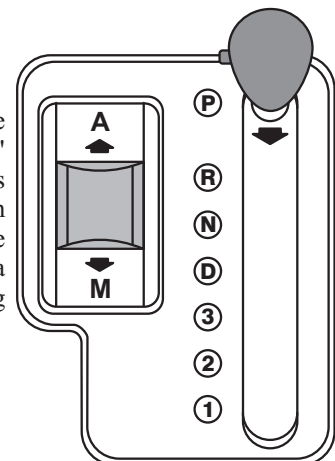
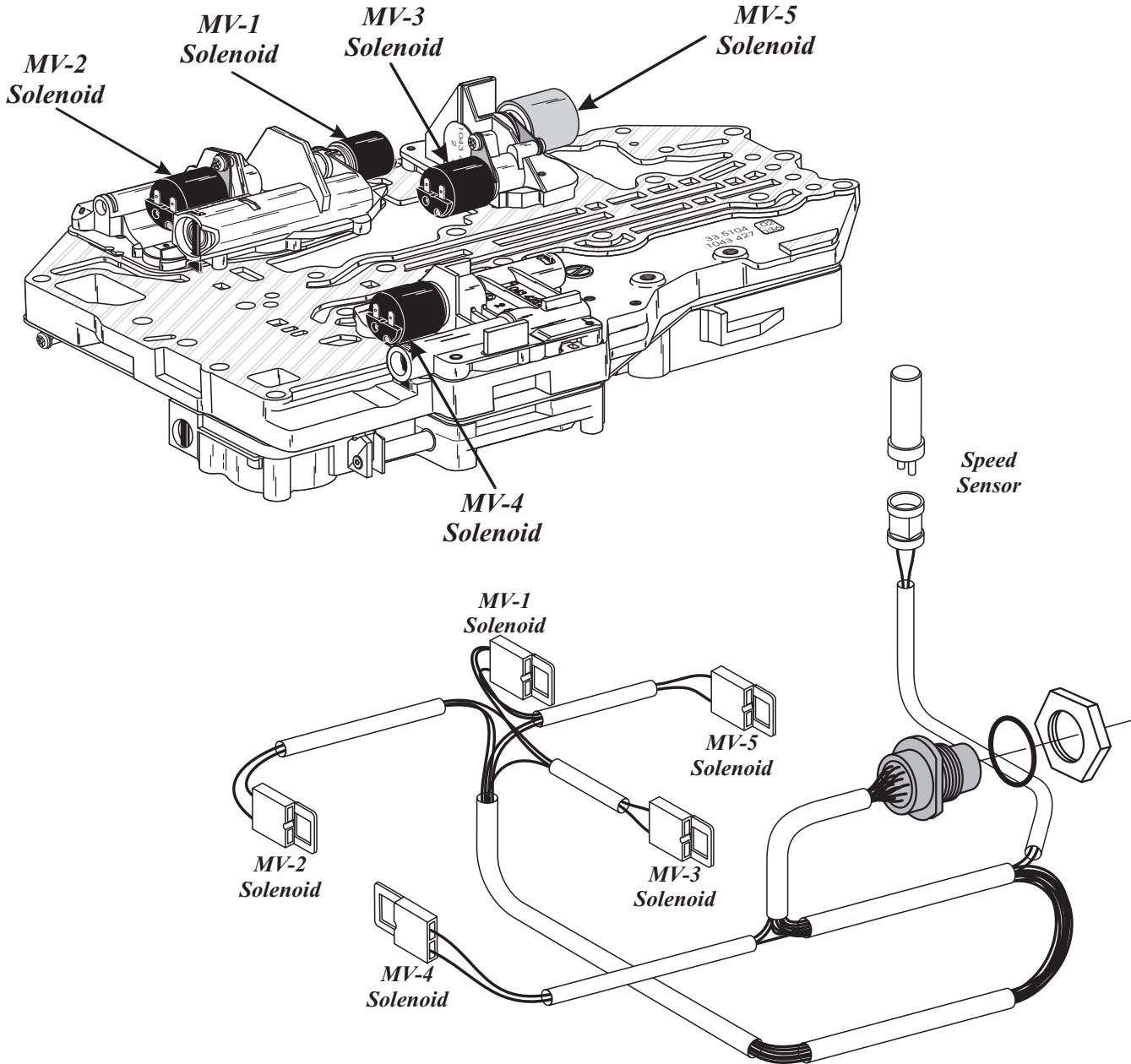

Figure 21

TECHNICIANS DIAGNOSTIC GUIDE BMW, AUDI, PORSCHE

ZF-4HP-22/24 MODEL "E-7", "5 SOLENOID" IDENTIFICATION, LOCATION AND FUNCTION



Solenoid	Function	Gear	MV-1	MV-2
MV-1	Shift Control	1st	ON	ON
MV-2	Shift Control	2nd	OFF	ON
		3rd	OFF	OFF
		4th	ON	OFF
MV-3	Lock-Up Control			
MV-4	Reverse Lockout			
MV-5	Line Pressure Control			

Copyright © 2003 ATSG

Figure 22

TECHNICIANS DIAGNOSTIC GUIDE

BMW, AUDI, PORSCHE

ZF-4HP-22/24 MODEL "E-7", "5 SOLENOID" INTERNAL WIRE SCHEMATIC AND CONNECTOR TERMINAL IDENTIFICATION

Note: The case connector on this unit is not numbered on connector for identification. ATSG has chosen the numbers you see so that you can use the chart below to do a resistance check on internal components.

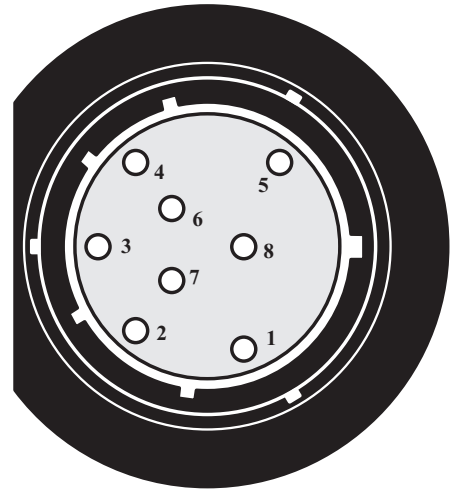

*View Looking Into
Case Connector*

<i>COMPONENT</i>	<i>TERMINALS</i>	<i>RESISTANCE</i>	<i>PART NUMBER</i>
<i>MV 1 Solenoid</i>	<i>5 And 6</i>	<i>30 - 34 Ohms</i>	<i>0501 307 869</i>
<i>MV 2 Solenoid</i>	<i>8 And 6</i>	<i>30 - 34 Ohms</i>	<i>0501 307 869</i>
<i>MV 3 Solenoid</i>	<i>7 And 6</i>	<i>30 - 34 Ohms</i>	<i>0501 307 869</i>
<i>MV 4 Solenoid</i>	<i>2 And 6</i>	<i>30 - 34 Ohms</i>	<i>0501 307 869</i>
<i>MV 5 Solenoid</i>	<i>1 And 6</i>	<i>2.5 - 4.5 Ohms</i>	<i>0501 206 997</i>
<i>Output Speed Sensor</i>	<i>3 And 4</i>	<i>265 Ohms (72° F)</i>	<i>0501 311 086</i>

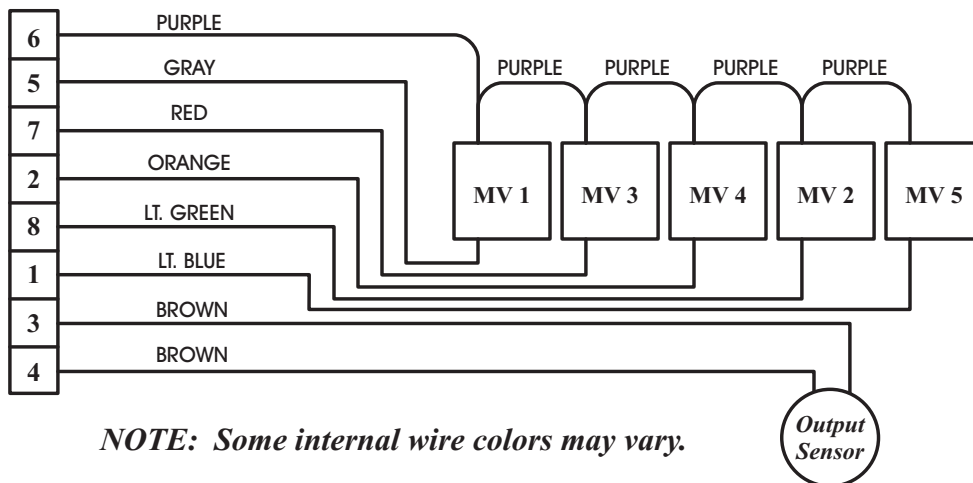

NOTE: Some internal wire colors may vary.

Copyright © 2003 ATSG

Figure 23

ZF-4HP-22 MODEL "E7", "5 SOLENOID" VALVE BODY, SOLENOID OPERATION MV1, 2, 3 AND 4 OPERATION

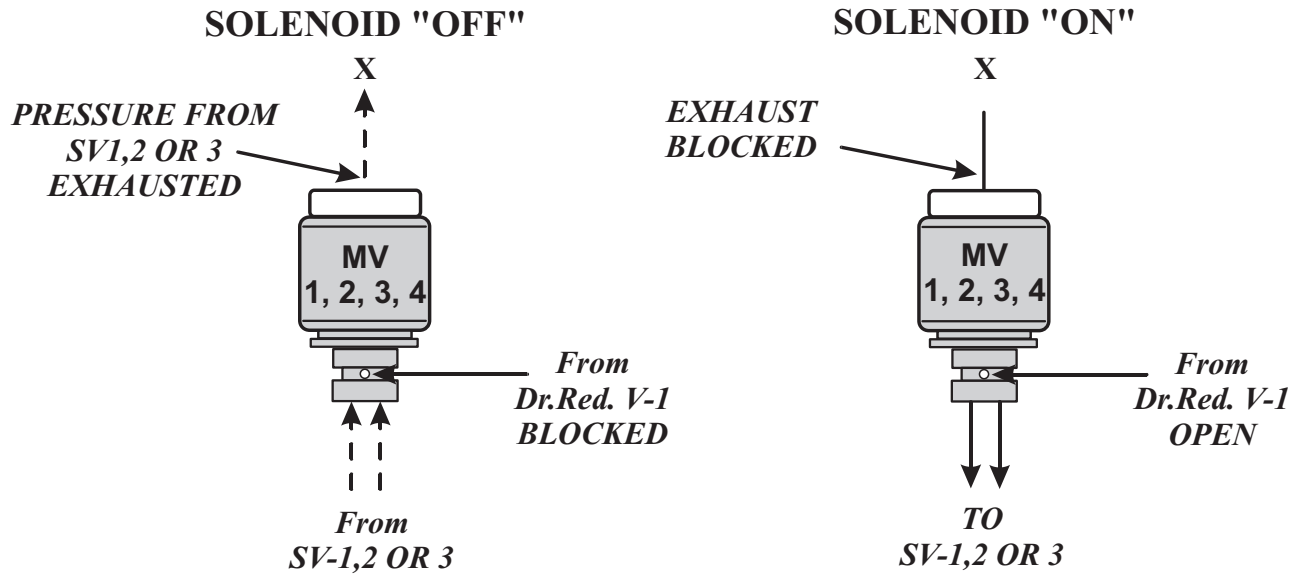

SUMMARY:

When MV 1, 2, 3 or 4 is "OFF" Solenoid reducing pressure, from Dr.Red. V-1, is blocked by the solenoid and oil pressure from SV 1, 2 or 3 is exhausted at the rear of the solenoid.

When MV 1, 2, 3 or 4 is "ON" Solenoid reducing pressure, From Dr.Red. V-1, is open through the solenoid and is applied to SV 1, 2 or 3. The exhaust at the rear of the solenoid is closed.

MV-5 OPERATION (Line Pressure Solenoid)

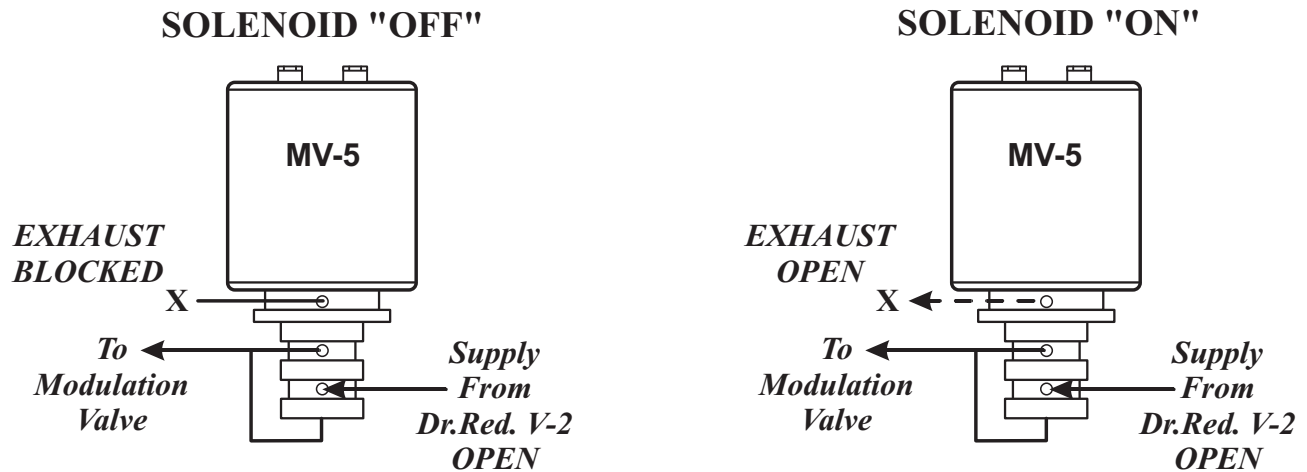

SUMMARY:

When MV-5 solenoid is "OFF," solenoid reducing pressure, from Dr. Red. V-2, is high to MOD-V valve which creates high line pressure.

When MV-5 solenoid is "ON," solenoid reducing pressure, from Dr. Red. V-2, is low to MOD-V valve which creates low line pressure.

Figure 24

**ZF-4HP-22/24 MODEL "E-7", "5 SOLENOID"
 VALVE BODY ASSEMBLY**

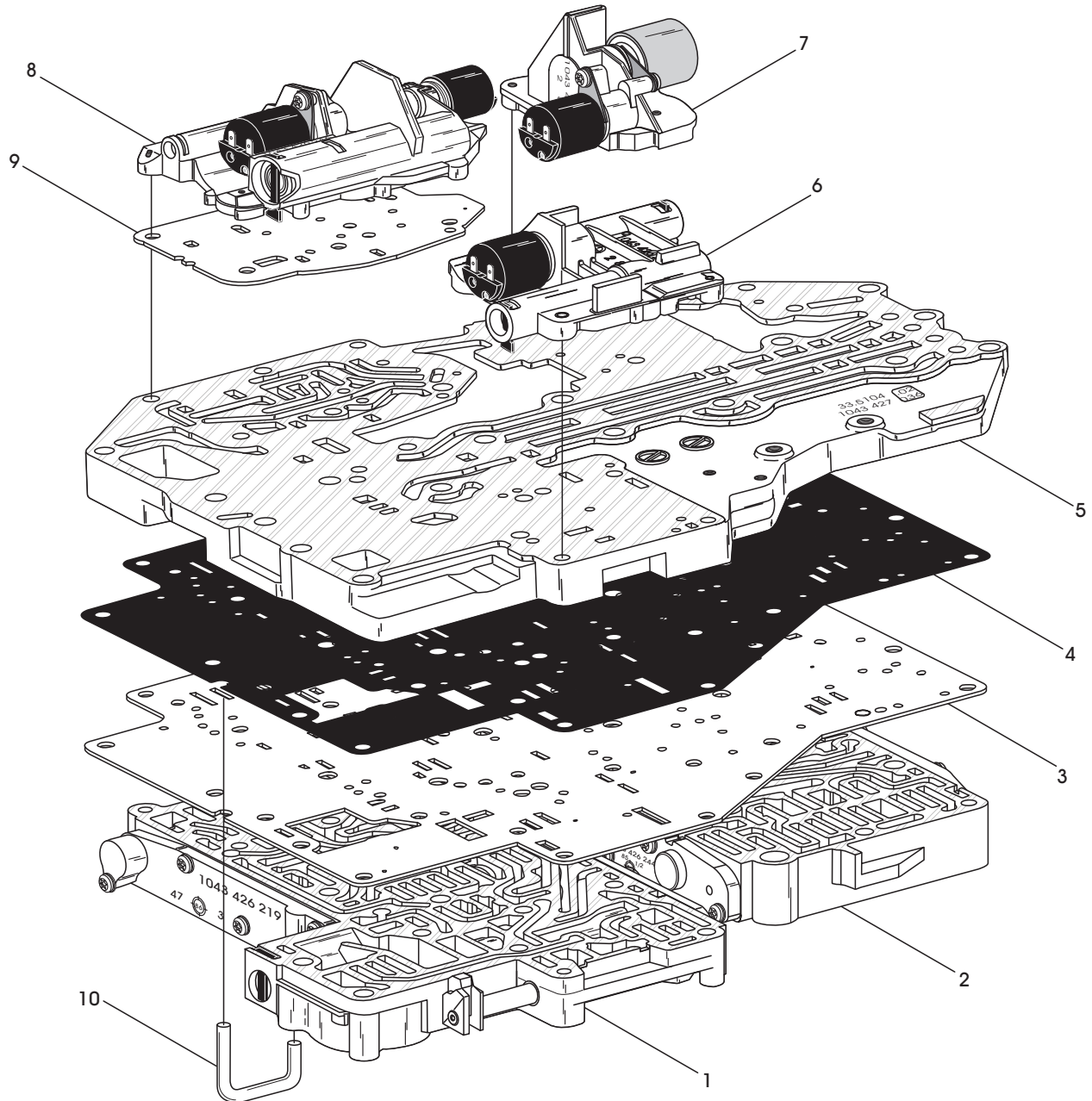

- 1 LOWER FRONT VALVE BODY ASSEMBLY
- 2 LOWER REAR VALVE BODY ASSEMBLY
- 3 VALVE BODY SPACER PLATE
- 4 SPACER PLATE TO CHANNEL PLATE GASKET
- 5 CHANNEL PLATE ASSEMBLY

- 6 MV-4 SOLENOID BODY ASSEMBLY
- 7 MV-3 AND MV-5 SOLENOID BODY ASSEMBLY
- 8 MV-1 AND MV-2 SOLENOID BODY ASSEMBLY
- 9 MV-1/MV-2 SOLENOID BODY TO CHANNEL PLATE SPACER PLATE
- 10 OIL PIPE, LOWER FRONT VALVE BODY TO CHANNEL PLATE

Copyright © 2003 ATSG

Figure 25

ZF-4HP-22/24 MODEL "E-7", "5 SOLENOID"
LOWER "FRONT" VALVE BODY

*Legend And Spring
 Specifications Found
 On Page 33.*

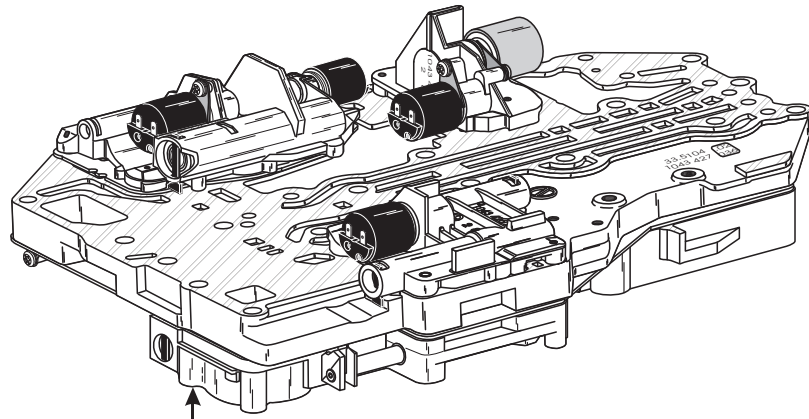

*Rear Side
 Exploded View*

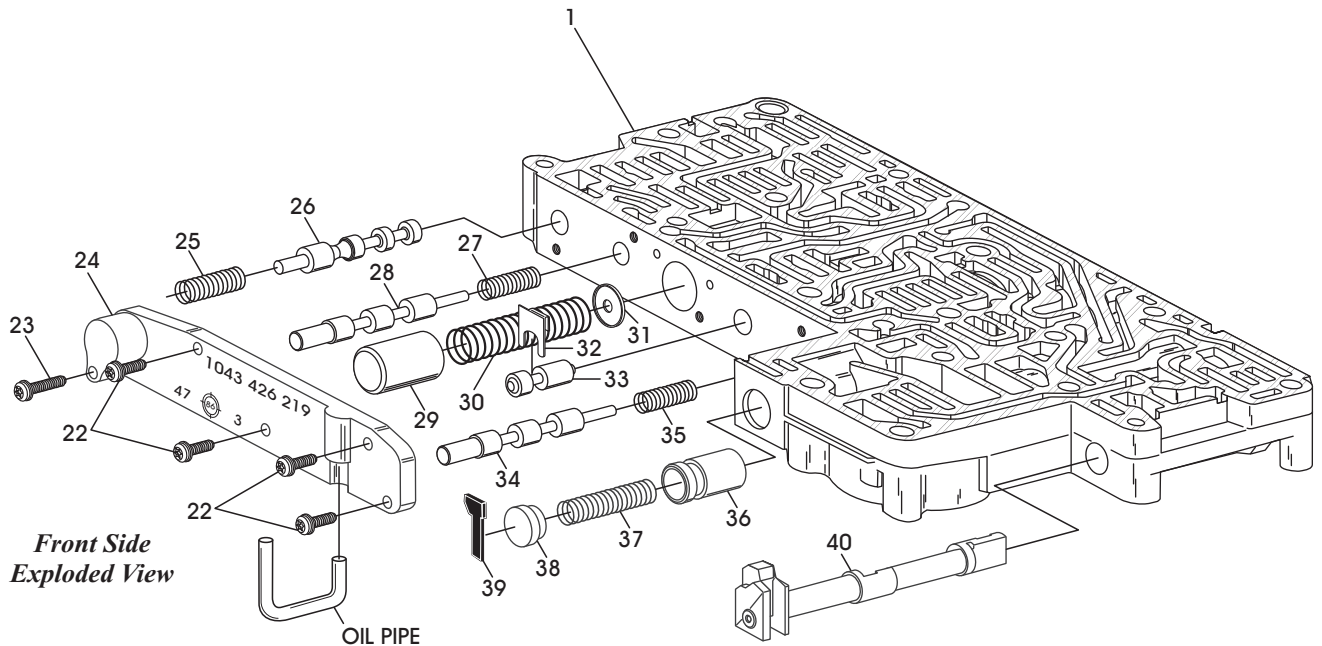
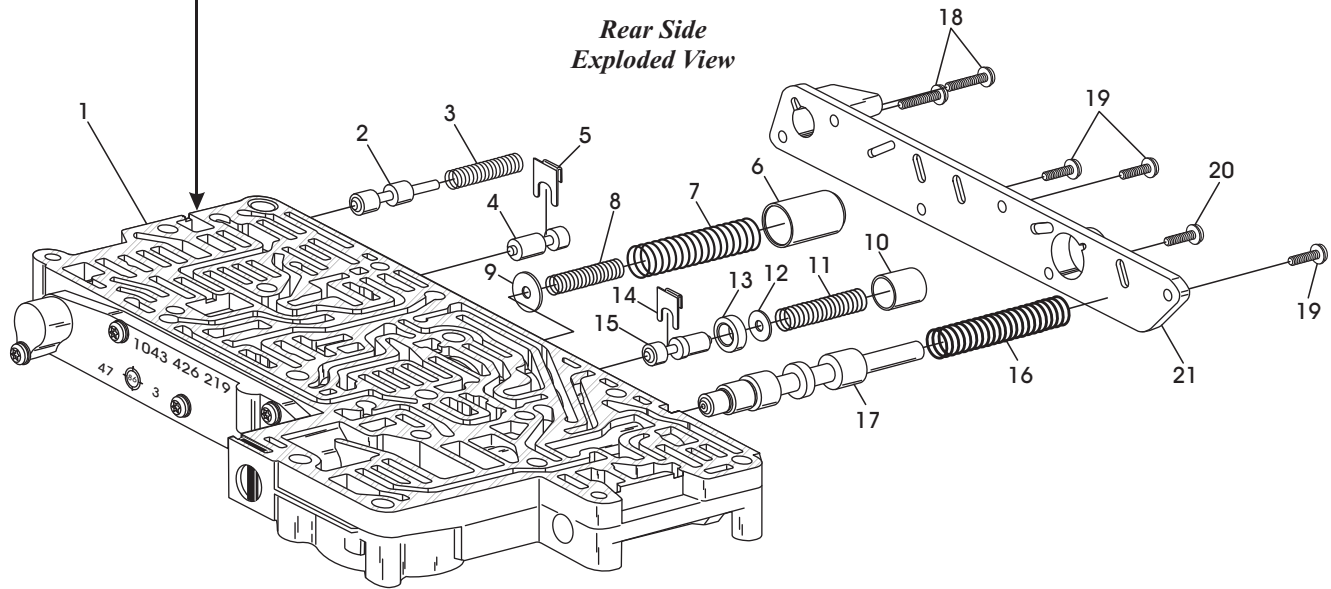

Copyright © 2003 ATSG

Figure 26

FIGURE 26 LEGEND AND SPRING SPECIFICATIONS

<ul style="list-style-type: none"> 1 LOWER FRONT VALVE BODY CASTING 2 "C" CLUTCH VALVE 3 "C" CLUTCH VALVE SPRING 4 "C" CLUTCH VALVE 5 "C" CLUTCH VALVE RETAINER 6 "B" CLUTCH DAMPER PISTON 7 "B" CLUTCH DAMPER PISTON OUTER SPRING 8 "B" CLUTCH DAMPER PISTON INNER SPRING 9 "B" CLUTCH DAMPER PISTON SPRING SEAT 10 "D" CLUTCH DAMPER PISTON 11 "D" CLUTCH DAMPER PISTON SPRING 12 "D" CLUTCH DAMPER PISTON SPRING SEAT 13 "D" CLUTCH VALVE SLEEVE 14 "D" CLUTCH VALVE RETAINER 15 "D" CLUTCH VALVE 16 PRESSURE REGULATOR VALVE SPRING 17 PRESSURE REGULATOR VALVE 18 REAR SIDE COVER RETAINING BOLT, 34 mm LENGTH (2) 19 REAR SIDE COVER RETAINING BOLT, 17 mm LENGTH (3) 20 REAR SIDE COVER RETAINING BOLT, 21 mm LENGTH (1) 21 REAR SIDE COVER 22 FRONT SIDE COVER RETAINING BOLT, 17 mm LENGTH (4) 23 FRONT SIDE COVER RETAINING BOLT, 29 mm LENGTH (1) 24 FRONT SIDE COVER 25 TORQUE CONVERTER LOCK-UP VALVE SPRING 26 TORQUE CONVERTER LOCK-UP VALVE 27 2-3 SHIFT VALVE SPRING 28 2-3 SHIFT VALVE 29 "C" CLUTCH DAMPER PISTON 30 "C" CLUTCH DAMPER PISTON SPRING 31 "C" CLUTCH DAMPER PISTON SPRING SEAT 32 "B" CLUTCH REGULATOR VALVE RETAINER 33 "B" CLUTCH REGULATOR VALVE 34 1-2 SHIFT VALVE 35 1-2 SHIFT VALVE SPRING 	<ul style="list-style-type: none"> 36 "A" CLUTCH DAMPER PISTON 37 "A" CLUTCH DAMPER SPRING 38 "A" CLUTCH DAMPER PISTON SPRING SEAT 39 "A" CLUTCH DAMPER SPRING SEAT RETAINER 40 MANUAL SHIFT VALVE <table border="0" style="width: 100%;"> <tr> <td style="width: 50%;"> SPRING ILLUSTRATION NO. 3: FREE LENGTH = 1.495" SPRING DIAMETER = .360" WIRE DIAMETER = .035" </td> <td style="width: 50%;"> SPRING ILLUSTRATION NO. 25: FREE LENGTH = 1.830" SPRING DIAMETER = .435" WIRE DIAMETER = .040" </td> </tr> <tr> <td> SPRING ILLUSTRATION NO. 7: FREE LENGTH = 3.160" SPRING DIAMETER = .595" WIRE DIAMETER = .044" </td> <td> SPRING ILLUSTRATION NO. 27: FREE LENGTH = 1.660" SPRING DIAMETER = .360" WIRE DIAMETER = .036" </td> </tr> <tr> <td> SPRING ILLUSTRATION NO. 8: FREE LENGTH = 1.560" SPRING DIAMETER = .430" WIRE DIAMETER = .040" </td> <td> SPRING ILLUSTRATION NO. 30: FREE LENGTH = 3.160" SPRING DIAMETER = .595" WIRE DIAMETER = .044" </td> </tr> <tr> <td> SPRING ILLUSTRATION NO. 11: FREE LENGTH = 1.653" SPRING DIAMETER = .550" WIRE DIAMETER = .044" </td> <td> SPRING ILLUSTRATION NO. 35: FREE LENGTH = 1.660" SPRING DIAMETER = .360" WIRE DIAMETER = .036" </td> </tr> <tr> <td> SPRING ILLUSTRATION NO. 16: FREE LENGTH = 3.575" SPRING DIAMETER = .600" WIRE DIAMETER = .080" </td> <td> SPRING ILLUSTRATION NO. 37: FREE LENGTH = 2.515" SPRING DIAMETER = .410" WIRE DIAMETER = .050" </td> </tr> </table>	SPRING ILLUSTRATION NO. 3: FREE LENGTH = 1.495" SPRING DIAMETER = .360" WIRE DIAMETER = .035"	SPRING ILLUSTRATION NO. 25: FREE LENGTH = 1.830" SPRING DIAMETER = .435" WIRE DIAMETER = .040"	SPRING ILLUSTRATION NO. 7: FREE LENGTH = 3.160" SPRING DIAMETER = .595" WIRE DIAMETER = .044"	SPRING ILLUSTRATION NO. 27: FREE LENGTH = 1.660" SPRING DIAMETER = .360" WIRE DIAMETER = .036"	SPRING ILLUSTRATION NO. 8: FREE LENGTH = 1.560" SPRING DIAMETER = .430" WIRE DIAMETER = .040"	SPRING ILLUSTRATION NO. 30: FREE LENGTH = 3.160" SPRING DIAMETER = .595" WIRE DIAMETER = .044"	SPRING ILLUSTRATION NO. 11: FREE LENGTH = 1.653" SPRING DIAMETER = .550" WIRE DIAMETER = .044"	SPRING ILLUSTRATION NO. 35: FREE LENGTH = 1.660" SPRING DIAMETER = .360" WIRE DIAMETER = .036"	SPRING ILLUSTRATION NO. 16: FREE LENGTH = 3.575" SPRING DIAMETER = .600" WIRE DIAMETER = .080"	SPRING ILLUSTRATION NO. 37: FREE LENGTH = 2.515" SPRING DIAMETER = .410" WIRE DIAMETER = .050"
SPRING ILLUSTRATION NO. 3: FREE LENGTH = 1.495" SPRING DIAMETER = .360" WIRE DIAMETER = .035"	SPRING ILLUSTRATION NO. 25: FREE LENGTH = 1.830" SPRING DIAMETER = .435" WIRE DIAMETER = .040"										
SPRING ILLUSTRATION NO. 7: FREE LENGTH = 3.160" SPRING DIAMETER = .595" WIRE DIAMETER = .044"	SPRING ILLUSTRATION NO. 27: FREE LENGTH = 1.660" SPRING DIAMETER = .360" WIRE DIAMETER = .036"										
SPRING ILLUSTRATION NO. 8: FREE LENGTH = 1.560" SPRING DIAMETER = .430" WIRE DIAMETER = .040"	SPRING ILLUSTRATION NO. 30: FREE LENGTH = 3.160" SPRING DIAMETER = .595" WIRE DIAMETER = .044"										
SPRING ILLUSTRATION NO. 11: FREE LENGTH = 1.653" SPRING DIAMETER = .550" WIRE DIAMETER = .044"	SPRING ILLUSTRATION NO. 35: FREE LENGTH = 1.660" SPRING DIAMETER = .360" WIRE DIAMETER = .036"										
SPRING ILLUSTRATION NO. 16: FREE LENGTH = 3.575" SPRING DIAMETER = .600" WIRE DIAMETER = .080"	SPRING ILLUSTRATION NO. 37: FREE LENGTH = 2.515" SPRING DIAMETER = .410" WIRE DIAMETER = .050"										

Copyright © 2003 ATSG

Figure 26 Legend

**ZF-4HP-22/24 MODEL "E-7", "5 SOLENOID"
 LOWER "REAR" VALVE BODY**

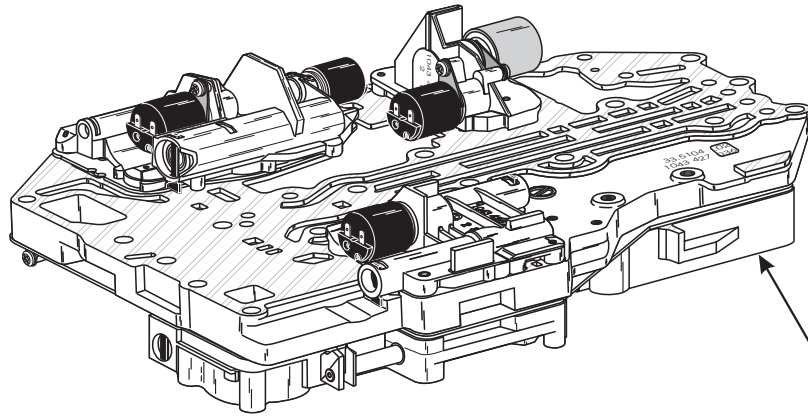

*Legend And Spring
 Specifications Found
 On Page 35.*

Rear Side Exploded View

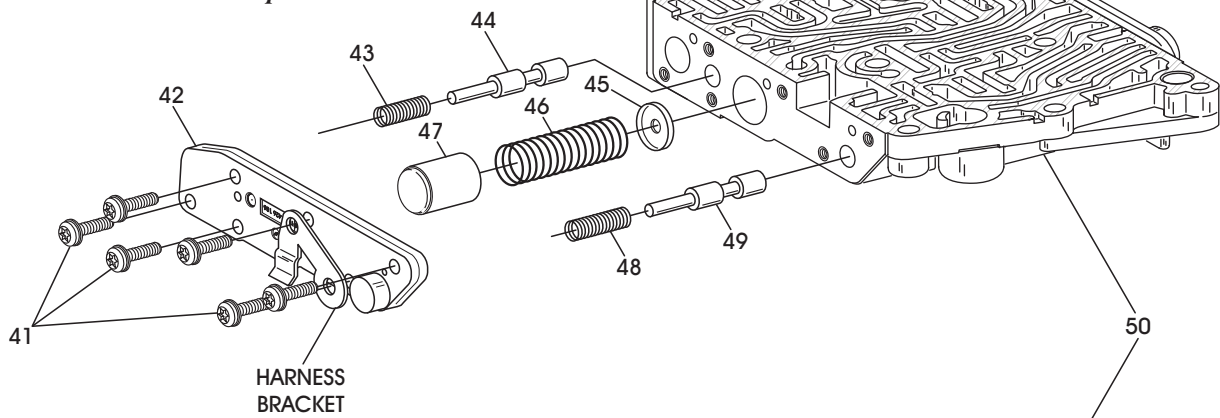

HARNESS
BRACKET

Front Side Exploded View

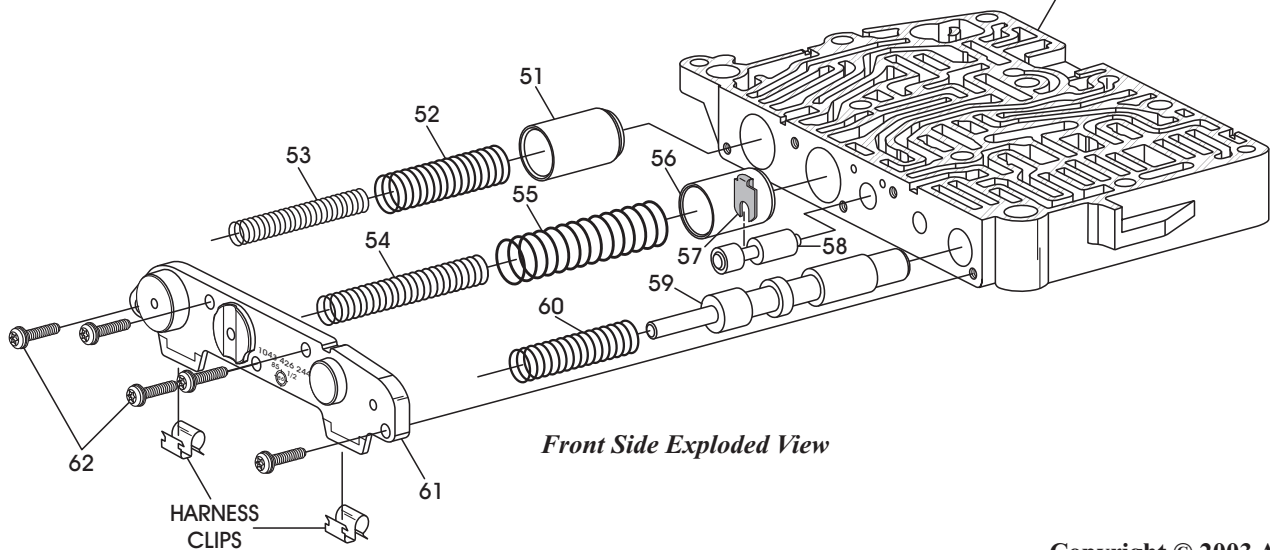

HARNESS
CLIPS

Figure 27



TECHNICIANS DIAGNOSTIC GUIDE

BMW, AUDI, PORSCHE

FIGURE 27 LEGEND AND SPRING SPECIFICATIONS

41 REAR SIDE COVER RETAINING BOLTS, 17 mm LENGTH (6)	SPRING ILLUSTRATION NO. 43: FREE LENGTH = 1.365" SPRING DIAMETER = .355" WIRE DIAMETER = .044"	SPRING ILLUSTRATION NO. 53: FREE LENGTH = 3.511" SPRING DIAMETER = .405" WIRE DIAMETER = .049"
42 REAR SIDE COVER		
43 PRESSURE REDUCING VALVE "2" SPRING		
44 PRESSURE REDUCING VALVE "2"		
45 "F" CLUTCH DAMPER PISTON SPRING SEAT		
46 "F" CLUTCH DAMPER PISTON SPRING	SPRING ILLUSTRATION NO. 46: FREE LENGTH = 3.290" SPRING DIAMETER = .600" WIRE DIAMETER = .043"	SPRING ILLUSTRATION NO. 54: FREE LENGTH = 4.556" SPRING DIAMETER = .510" WIRE DIAMETER = .037"
47 "F" CLUTCH DAMPER PISTON		
48 PRESSURE REDUCING VALVE "1" SPRING		
49 PRESSURE REDUCING VALVE "1"		
50 LOWER REAR VALVE BODY CASTING		
51 "C" CLUTCH DAMPER PISTON	SPRING ILLUSTRATION NO. 48: FREE LENGTH = 1.535" SPRING DIAMETER = .365" WIRE DIAMETER = .044"	SPRING ILLUSTRATION NO. 55: FREE LENGTH = 3.330" SPRING DIAMETER = .685" WIRE DIAMETER = .070"
52 "C" CLUTCH DAMPER PISTON OUTER SPRING		
53 "C" CLUTCH DAMPER PISTON INNER SPRING		
54 "E" CLUTCH DAMPER PISTON INNER SPRING		
55 "E" CLUTCH DAMPER PISTON OUTER SPRING		
56 "E" CLUTCH DAMPER PISTON	SPRING ILLUSTRATION NO. 52: FREE LENGTH = 2.945" SPRING DIAMETER = .600" WIRE DIAMETER = .066"	SPRING ILLUSTRATION NO. 60: FREE LENGTH = 2.445" SPRING DIAMETER = .472" WIRE DIAMETER = .040"
57 "F" CLUTCH VALVE RETAINER		
58 "F" CLUTCH VALVE		
59 3-4 SHIFT VALVE		
60 3-4 SHIFT VALVE SPRING		
61 FRONT SIDE COVER		
62 FRONT SIDE COVER RETAINING BOLTS, 17 mm LENGTH (5)		

Figure 27 Legend

ZF-4HP-22/24 MODEL "E-7", "5 SOLENOID" SHIFT SOLENOID BODY

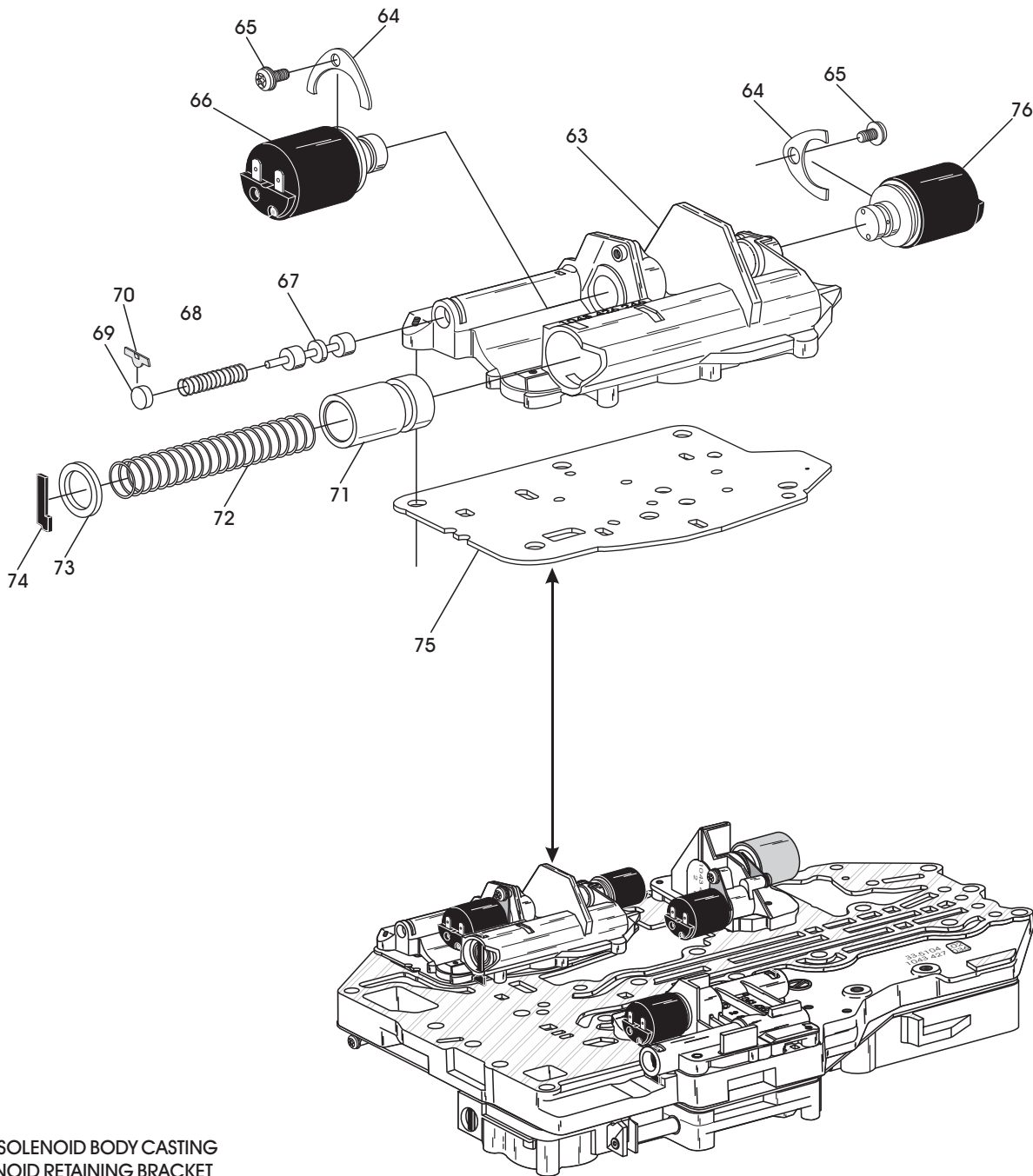

- 63 SHIFT SOLENOID BODY CASTING
- 64 SOLENOID RETAINING BRACKET
- 65 SOLENOID RETAINING BOLT, 11 mm LENGTH
- 66 MV-2 SHIFT SOLENOID ASSEMBLY
- 67 1-2 AND 3-4 SHIFT CONTROL VALVE
- 68 1-2 AND 3-4 SHIFT CONTROL VALVE SPRING
- 69 1-2 AND 3-4 SHIFT CONTROL VALVE BORE PLUG
- 70 1-2 AND 3-4 SHIFT CONTROL BORE PLUG RETAINER
- 71 T.C.C. LOCK-UP DAMPER PISTON
- 72 T.C.C. LOCK-UP DAMPER PISTON SPRING
- 73 T.C.C. LOCK-UP DAMPER PISTON SPRING SEAT
- 74 T.C.C. LOCK-UP DAMPER PISTON SPRING SEAT RETAINER
- 75 SOLENOID BODY TO CHANNEL PLATE SPACER PLATE
- 76 MV-1 SHIFT SOLENOID ASSEMBLY

SPRING ILLUSTRATION NO. 68:
 FREE LENGTH = 1.542"
 SPRING DIAMETER = .372"
 WIRE DIAMETER = .035"

SPRING ILLUSTRATION NO. 72:
 FREE LENGTH = 3.622"
 SPRING DIAMETER = .422"
 WIRE DIAMETER = .044"

Figure 28

**ZF-4HP-22/24 MODEL "E-7", "5 SOLENOID"
 PRESSURE CONTROL SOLENOID BODY**

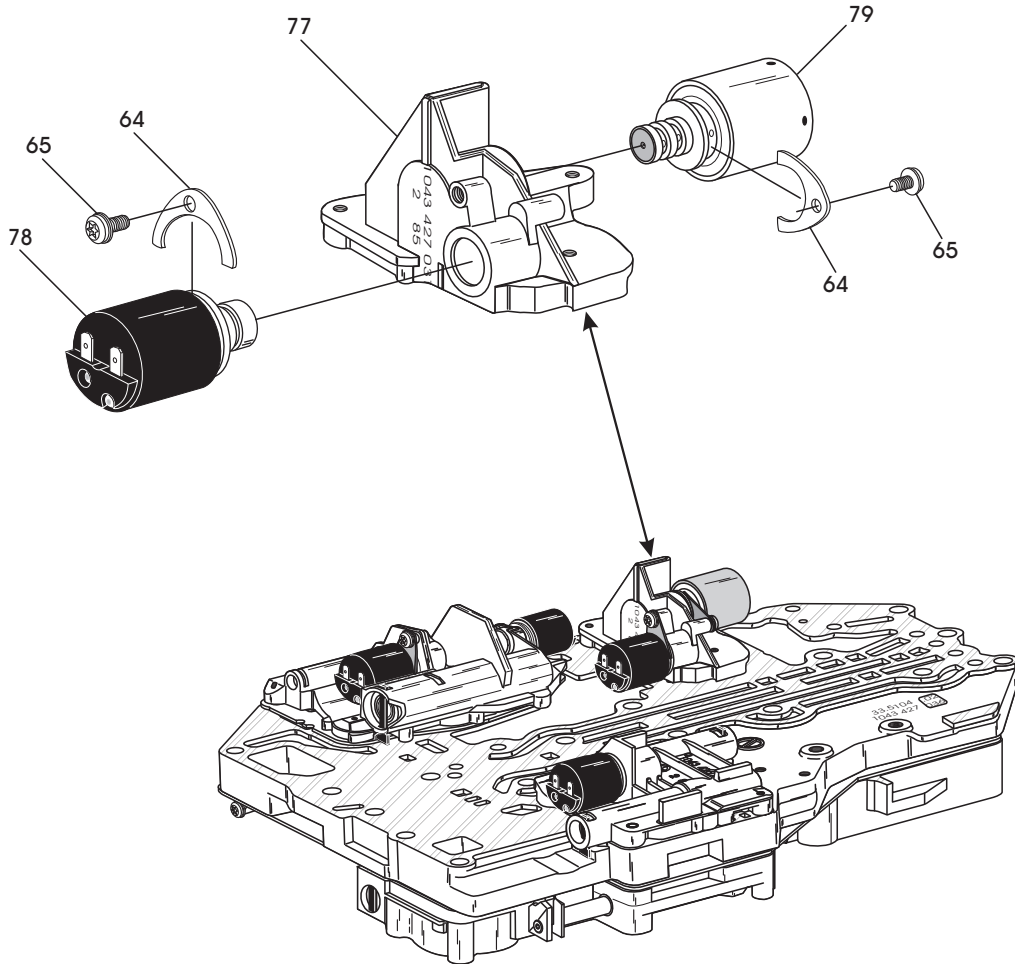

- 64 SOLENOID RETAINING BRACKET
- 65 SOLENOID RETAINING BOLT, 11 mm LENGTH
- 77 PRESSURE CONTROL SOLENOID BODY CASTING
- 78 MV-3 LOCK-UP CONTROL SOLENOID ASSEMBLY
- 79 MV-5 PRESSURE CONTROL SOLENOID ASSEMBLY

Figure 29

ZF-4HP-22/24 MODEL "E-7", "5 SOLENOID" REVERSE LOCKOUT SOLENOID BODY

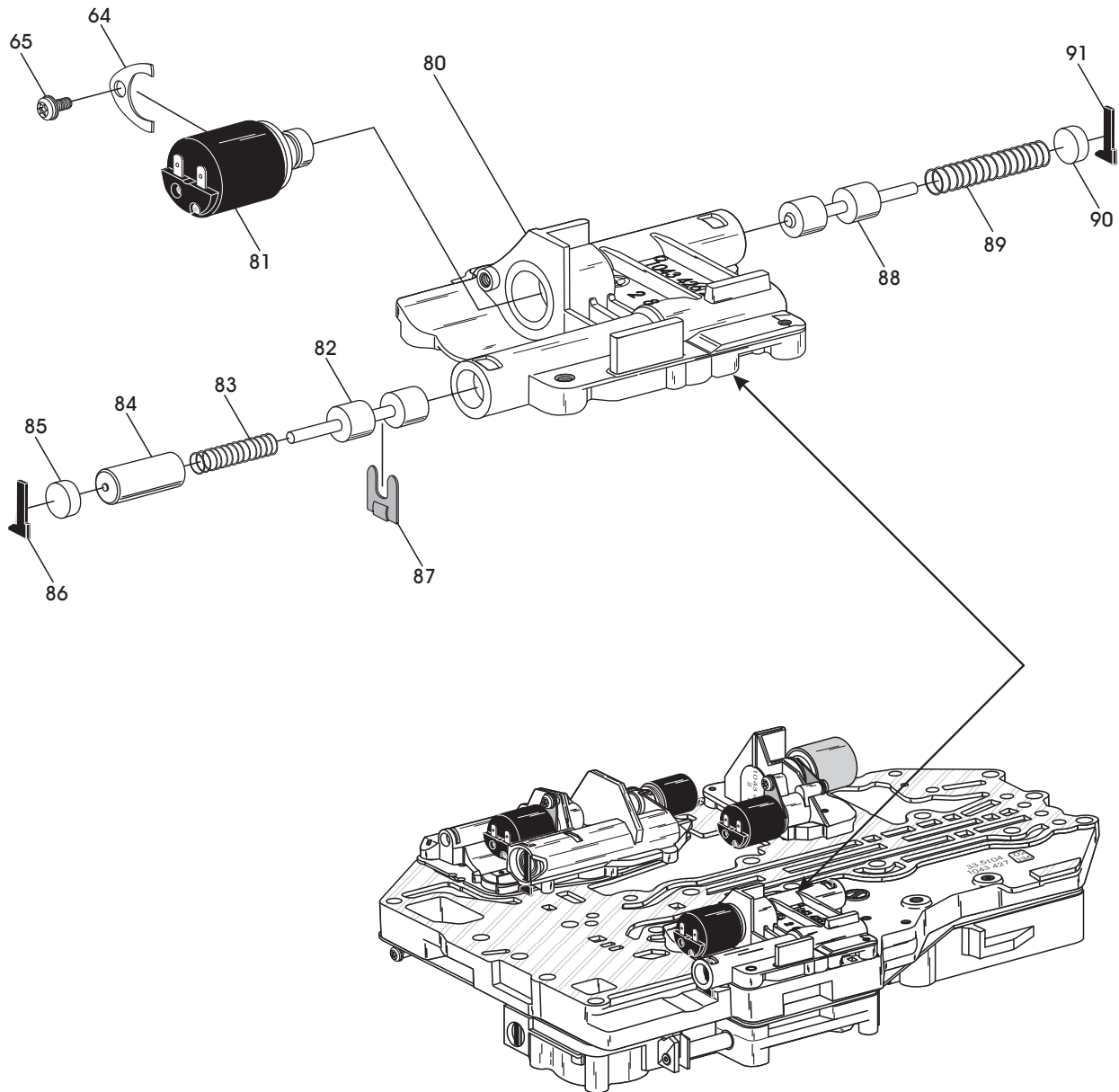

- 64 SOLENOID RETAINING BRACKET
- 65 SOLENOID RETAINING BOLT, 11 mm LENGTH
- 80 REVERSE LOCKOUT SOLENOID BODY CASTING
- 81 MV-4 REVERSE LOCKOUT SOLENOID ASSEMBLY
- 82 MODULATION VALVE
- 83 MODULATION VALVE SPRING
- 84 MODULATION VALVE SLEEVE
- 85 MODULATION VALVE BORE PLUG
- 86 MODULATION VALVE BORE PLUG RETAINER
- 87 MODULATION VALVE RETAINER
- 88 REVERSE LOCKOUT VALVE
- 89 REVERSE LOCKOUT VALVE SPRING
- 90 REVERSE LOCKOUT VALVE SPRING SEAT
- 91 REVERSE LOCKOUT SPRING SEAT RETAINER

SPRING ILLUSTRATION NO. 83:
 FREE LENGTH = 1.480"
 SPRING DIAMETER = .310"
 WIRE DIAMETER = .035"

SPRING ILLUSTRATION NO. 89:
 FREE LENGTH = 1.870"
 SPRING DIAMETER = .380"
 WIRE DIAMETER = .035"

Copyright © 2003 ATSG

Figure 30

**ZF-4HP-22/24 MODEL "E-7", "5 SOLENOID"
LOWER "FRONT" VALVE BODY**

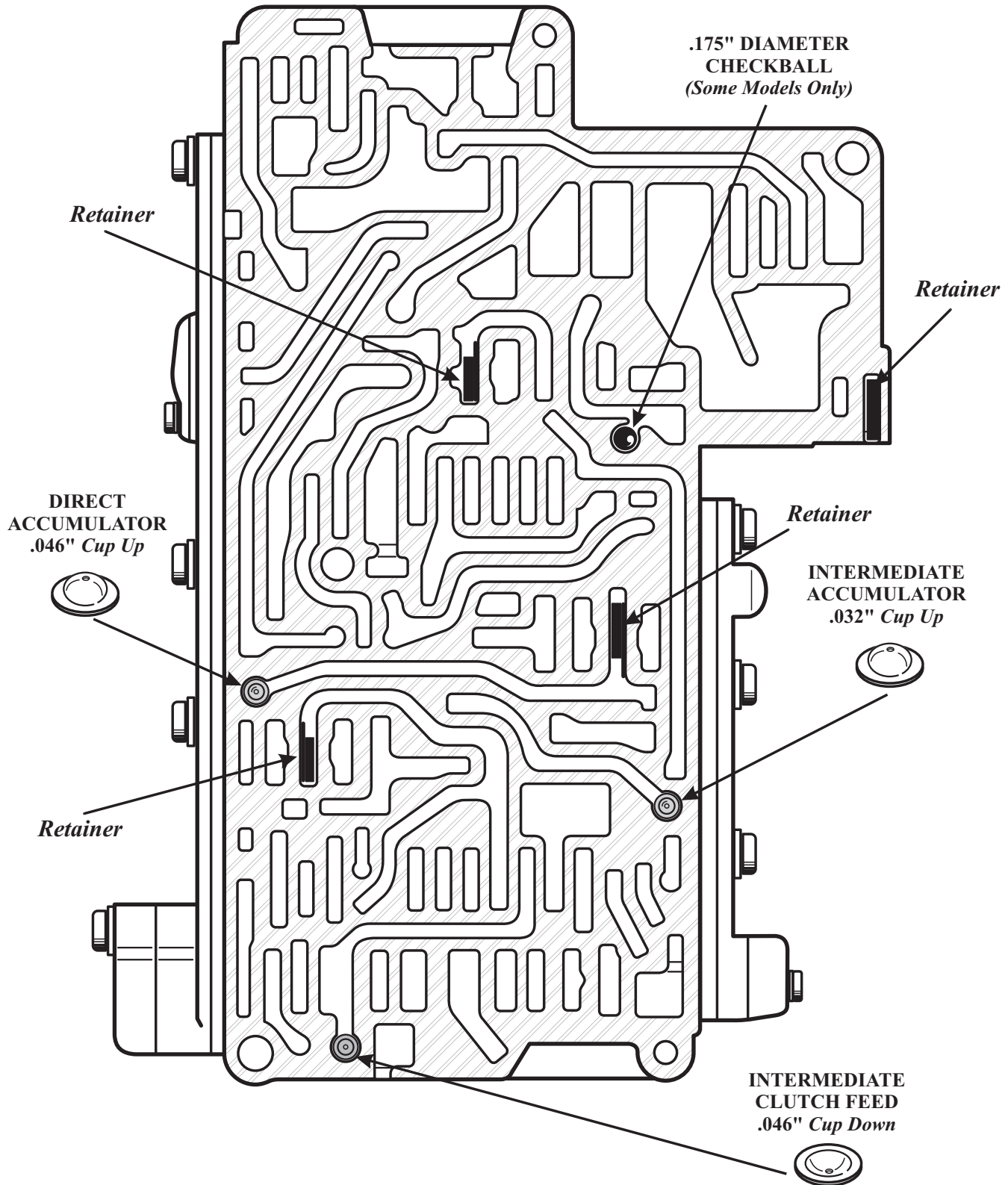

Copyright © 2003 ATSG

Figure 31

**ZF-4HP-22/24 MODEL "E-7", "5 SOLENOID"
LOWER "REAR" VALVE BODY**

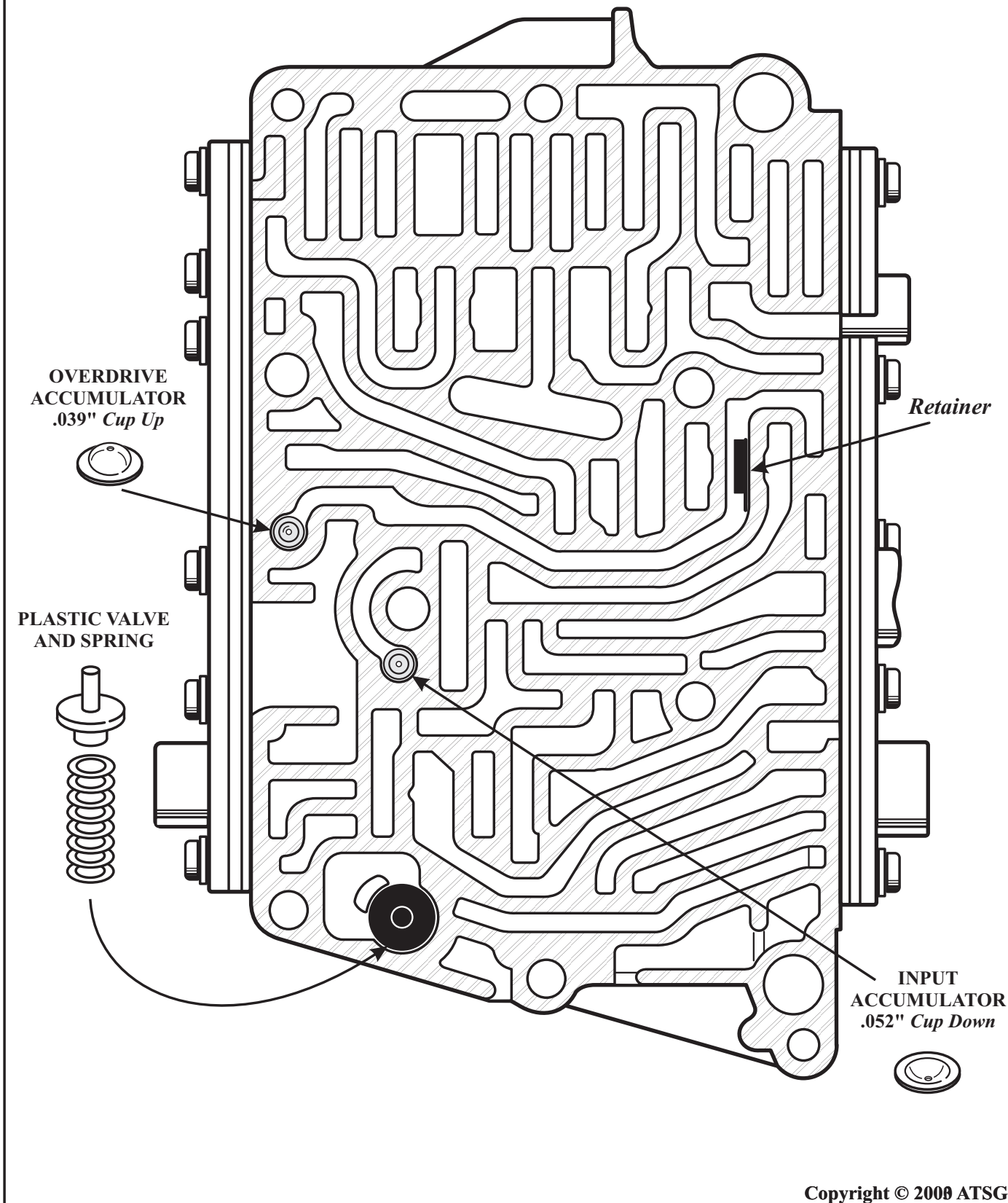

Copyright © 2008 ATSG

Figure 32

**ZF-4HP-22/24 MODEL "E-7", "5 SOLENOID"
CHANNEL PLATE**

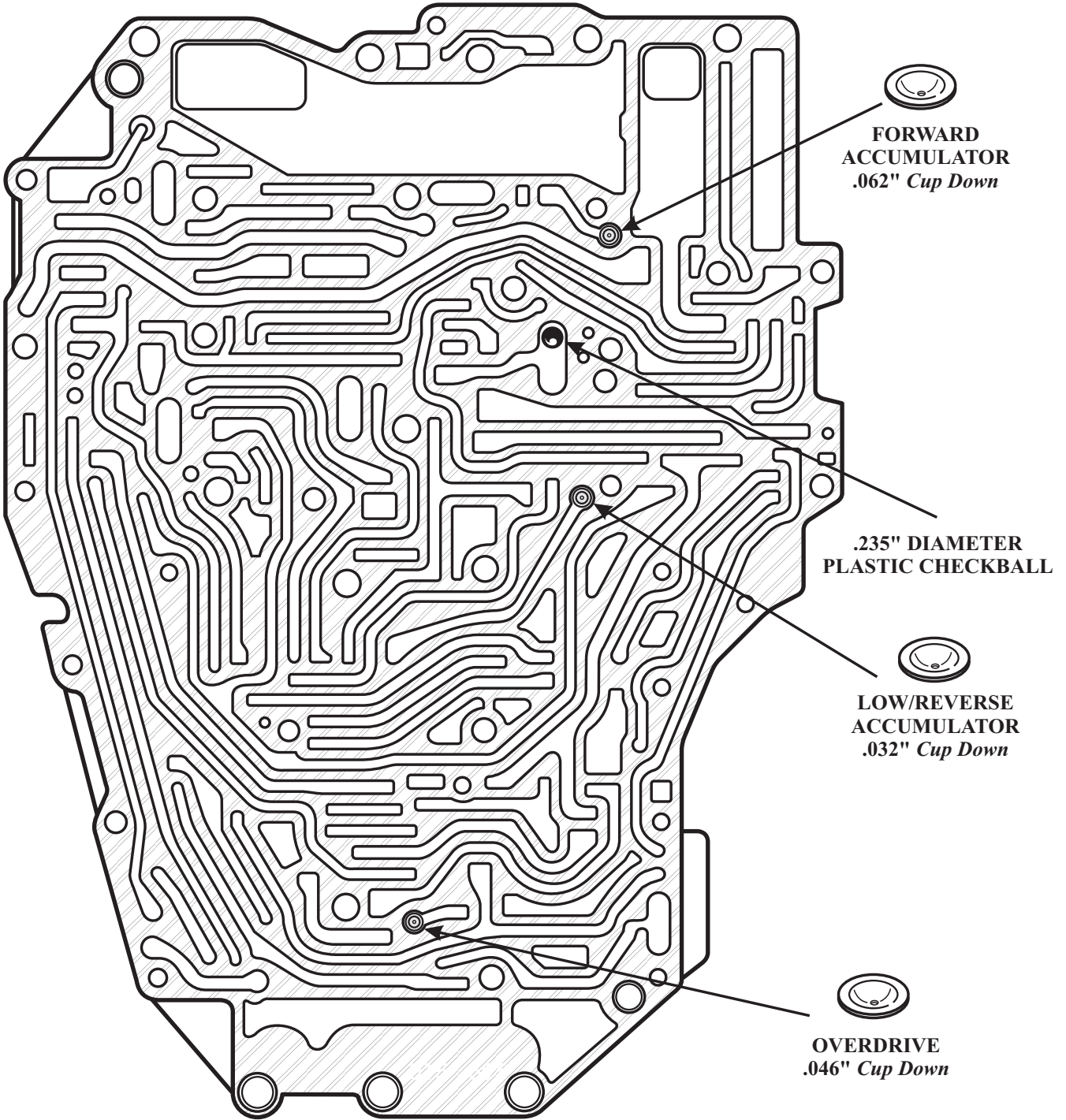

Copyright © 2003 ATSG

Figure 33

**ZF-4HP-22/24 MODEL "E-7", "5 SOLENOID"
ALL SOLENOID BODIES**

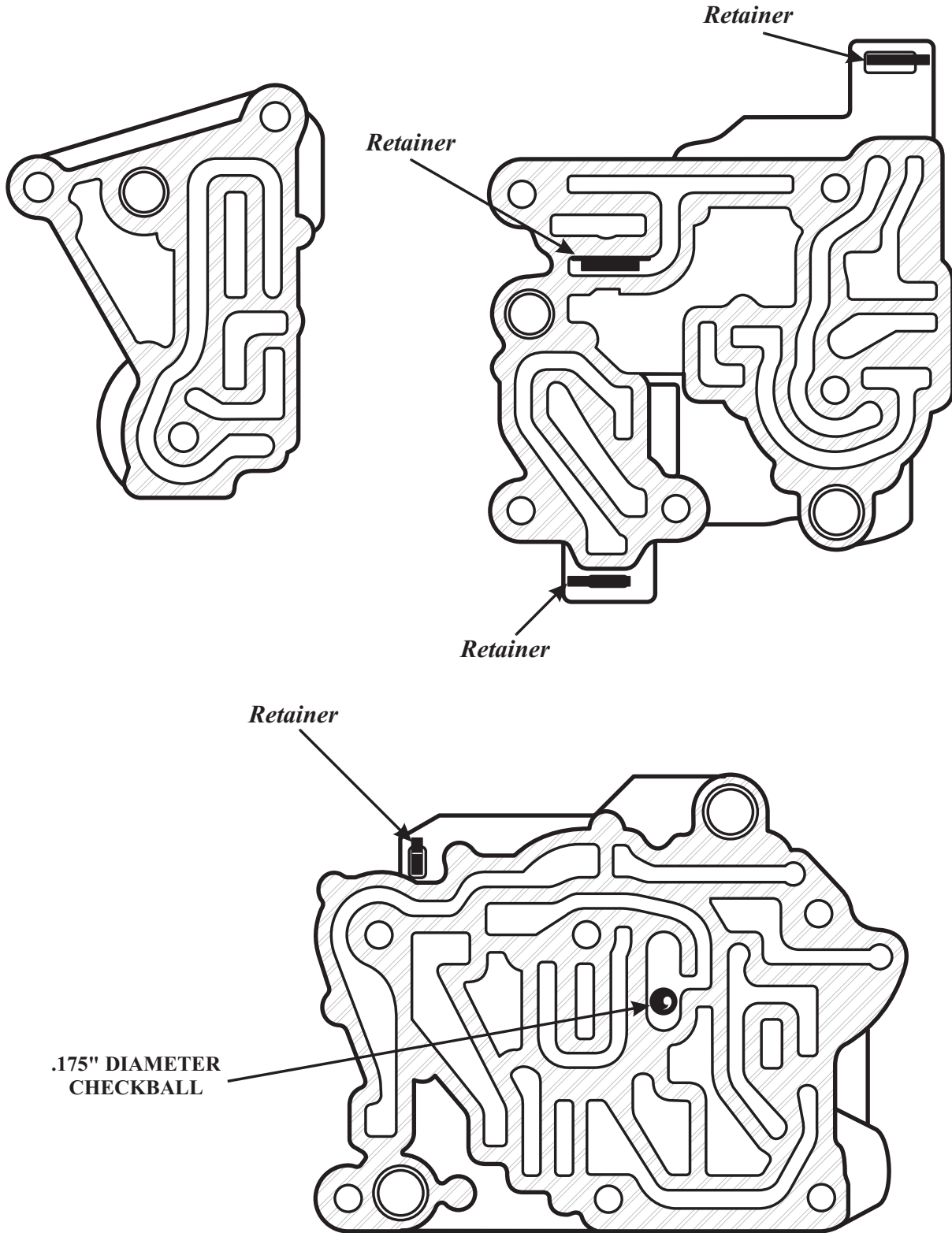

Figure 34

TECHNICIANS DIAGNOSTIC GUIDE BMW, AUDI, PORSCHE

ZF 4HP-22/24 SERIES DIAGNOSTIC INFORMATION

FOR MODEL "E9", "4 SOLENOID" VALVE BODY

Refer to Figure 36 for identification, location and function of the 5 solenoids, along with the shift solenoid firing order for the "E9" 4 solenoid models.

Refer to Figure 37 for internal wire schematic and case connector terminal identification, along with a resistance chart to check the internal electronic components.

Refer to Figure 38 for individual solenoid operation.

Refer to Figure 39 for Complete Valve Body Assembly exploded view.

Refer to Figure 40 for Lower Front Valve Body exploded view, with valve identifications.

Refer to Figure 41 for Lower Rear Valve Body exploded view, with valve identifications.

Refer to Figure 42 for MV-5 Solenoid Body exploded view, with valve identifications.

Refer to Figure 43 for MV-1 and MV-2 Solenoid Body exploded view, with valve identifications.

Refer to Figure 44 for MV-3 Lock-Up Solenoid Body exploded view, with identifications.

Refer to Figures 45, 46, 47 and 48 for retainer, checkball, and orifice locations.

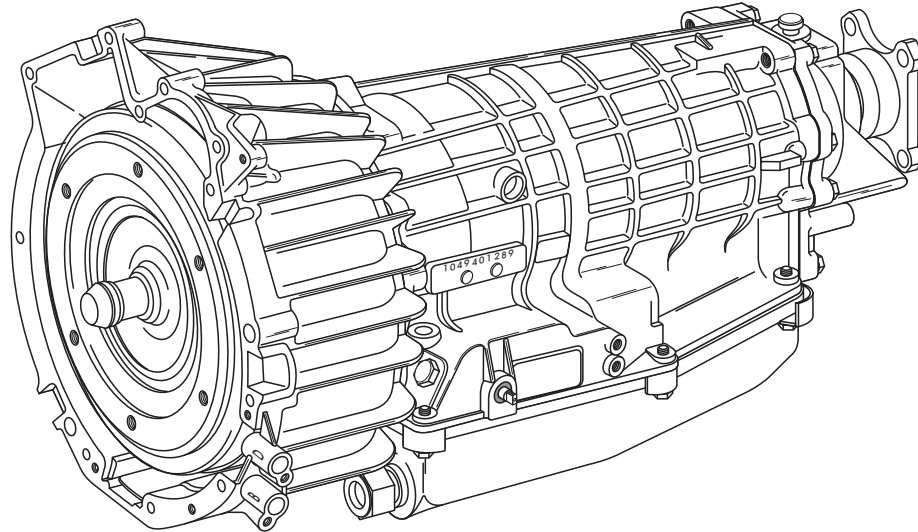

MODEL YEAR USAGE CHART

<i>Valve Body Models</i>	<i>Model Year</i>								
	86	87	88	89	90	91	92	93	94
<i>1st Version, Early "E-7", 5 Solenoid</i>									
<i>2nd Version, Late "E-7", 5 Solenoid</i>									
<i>3rd Version, "E-9", 4 Solenoid</i>									

Copyright © 2003 ATSG

Figure 35

TECHNICIANS DIAGNOSTIC GUIDE

BMW, AUDI, PORSCHE

ZF-4HP-22/24 MODEL "E-9", "4 SOLENOID" IDENTIFICATION, LOCATION AND FUNCTION

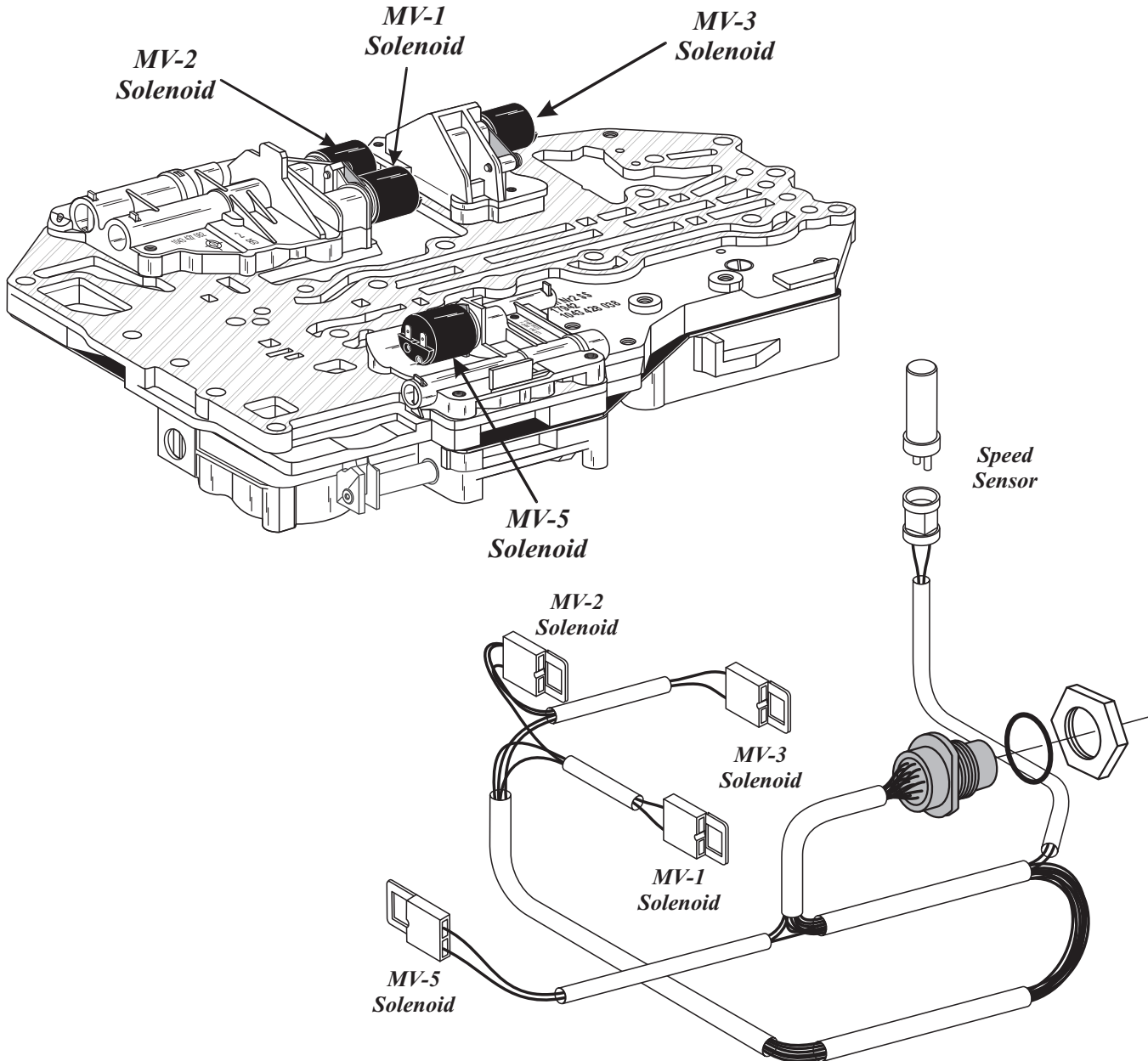

Solenoid	Function	Gear	MV-1	MV-2
MV-1	Shift Control	1st	OFF	ON
MV-2	Shift Control	2nd	ON	ON
		3rd	ON	OFF
		4th	OFF	OFF
		Rev 0 mph	ON	OFF
		Rev Above 3 mph	OFF	ON
MV-3	Lock-Up Control			
MV-5	Line Pressure Control			

Copyright © 2003 ATSG

Figure 36

TECHNICIANS DIAGNOSTIC GUIDE BMW, AUDI, PORSCHE

ZF-4HP-22/24 MODEL "E-9", "4 SOLENOID" INTERNAL WIRE SCHEMATIC AND CONNECTOR TERMINAL IDENTIFICATION

Note: The case connector on this unit is not numbered on connector for identification. ATSG has chosen the numbers you see so that you can use the chart below to do a resistance check on internal components.

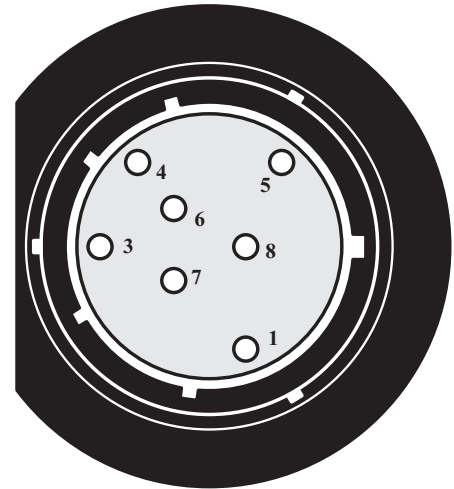

*View Looking Into
Case Connector*

<i>COMPONENT</i>	<i>TERMINALS</i>	<i>RESISTANCE</i>	<i>PART NUMBER</i>
<i>MV 1 Solenoid</i>	<i>5 And 6</i>	<i>30 - 34 Ohms</i>	<i>0501 310 967</i>
<i>MV 2 Solenoid</i>	<i>8 And 6</i>	<i>30 - 34 Ohms</i>	<i>0501 310 967</i>
<i>MV 3 Solenoid</i>	<i>7 And 6</i>	<i>30 - 34 Ohms</i>	<i>0501 310 967</i>
<i>MV 5 Solenoid</i>	<i>1 And 6</i>	<i>4.5 - 6.5 Ohms</i>	<i>0501 311 500</i>
<i>Output Speed Sensor</i>	<i>3 And 4</i>	<i>265 Ohms (72° F)</i>	<i>0501 311 086</i>

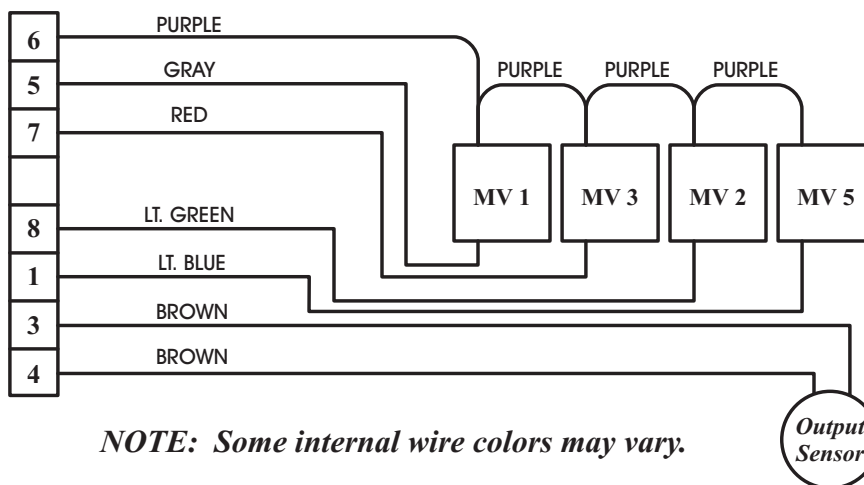

NOTE: Some internal wire colors may vary.

Copyright © 2003 ATSG

Figure 37

ZF-4HP-22/24 MODEL "E-9", "4 SOLENOID" VALVE BODY, SOLENOID OPERATION

MV1-MV3

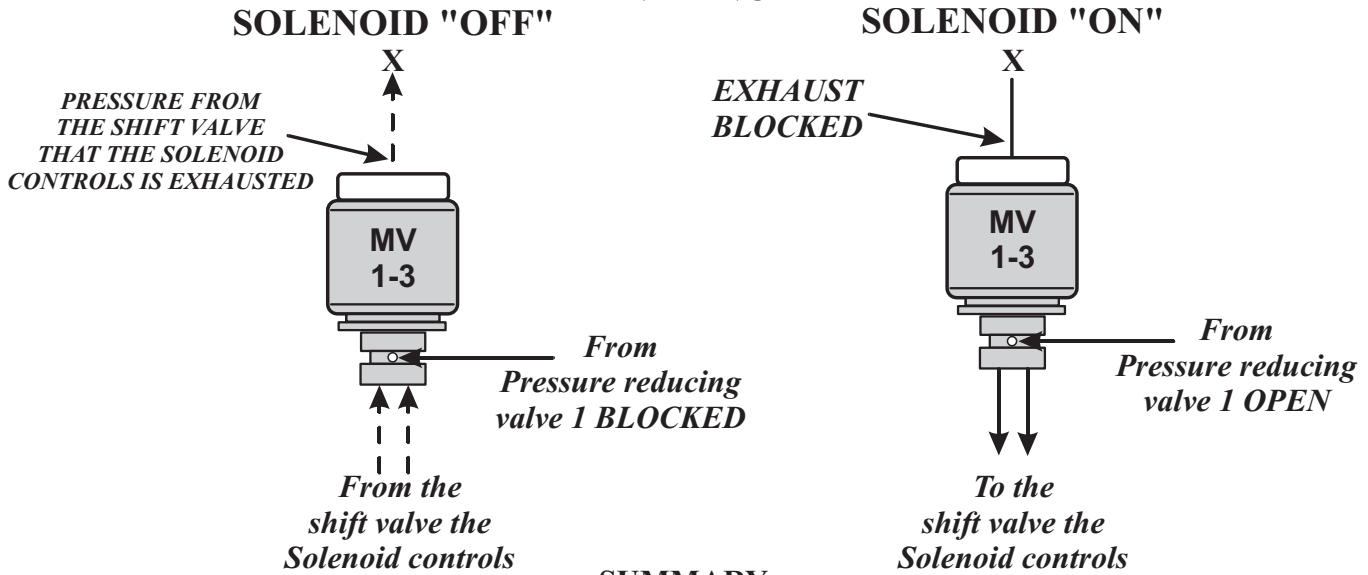

SUMMARY:

When MV 1 thru 3 is in the "OFF" state, Solenoid reducing pressure, from Pressure reducing valve 1, is blocked by the solenoid and oil pressure from the valve that the solenoid controls is exhausted at the rear of the solenoid.

When MV 1 thru 3 is in the "ON" state, Solenoid reducing pressure, from Pressure reducing valve 1, is open through the solenoid and is applied to the valve that the solenoid controls. The exhaust at the rear of the solenoid is closed.

MV-5

(Line Pressure Solenoid)

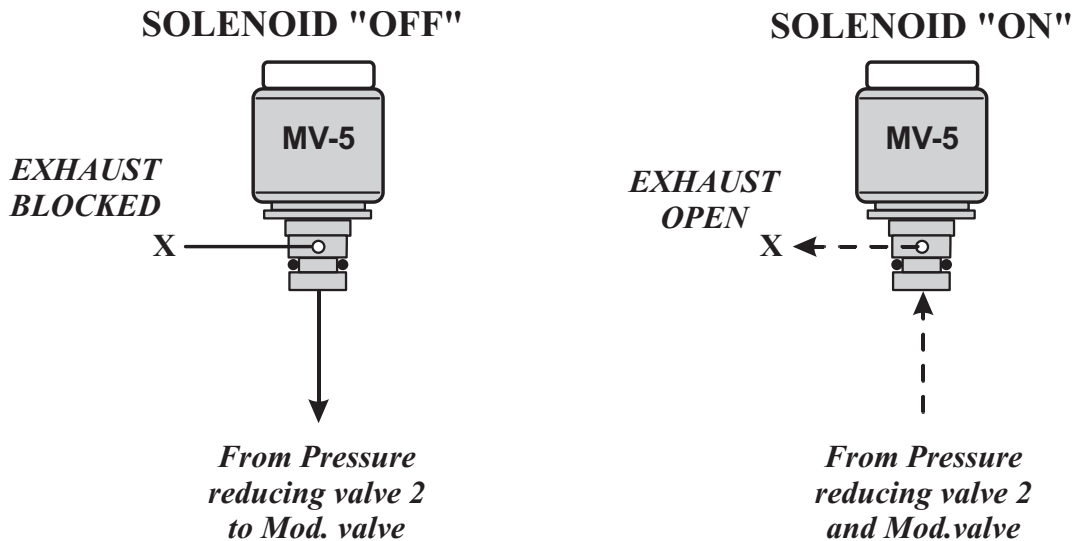

SUMMARY:

When MV-5 solenoid is "OFF," solenoid reducing pressure, from Pressure reducing valve 2, is high to the Modulating valve which creates high line pressure.

When MV-5 solenoid is "ON," solenoid reducing pressure, from Pressure reducing valve 2, is low to the Modulating valve which creates low line pressure.

Figure 38

**ZF-4HP-22/24 MODEL "E-9", "4 SOLENOID"
 VALVE BODY ASSEMBLY**

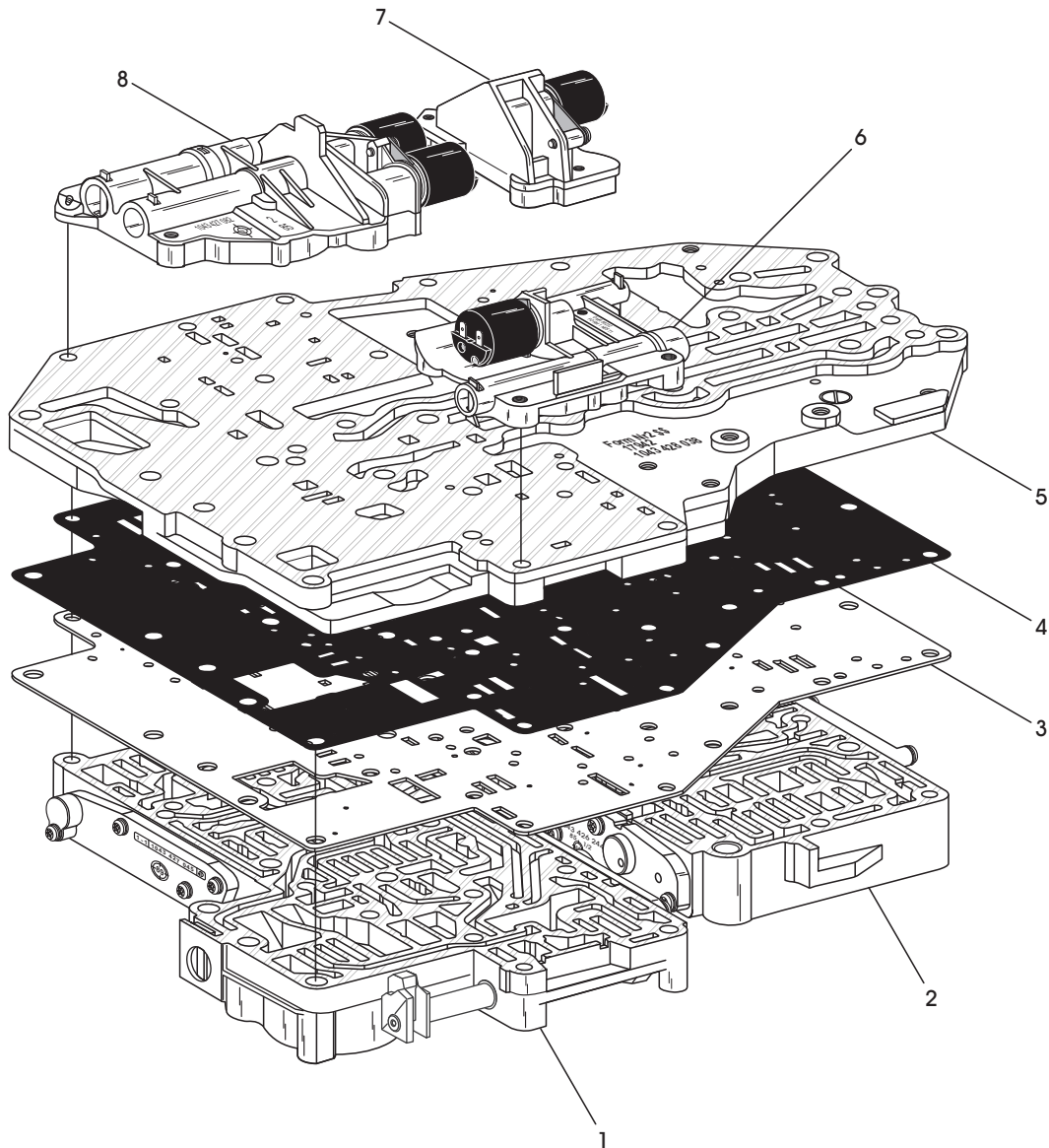

- 1 LOWER FRONT VALVE BODY ASSEMBLY
- 2 LOWER REAR VALVE BODY ASSEMBLY
- 3 VALVE BODY SPACER PLATE
- 4 SPACER PLATE TO CHANNEL PLATE GASKET
- 5 CHANNEL PLATE ASSEMBLY

- 6 MV-5 SOLENOID BODY ASSEMBLY
- 7 MV-3 SOLENOID BODY ASSEMBLY
- 8 MV-1 AND MV-2 SOLENOID BODY ASSEMBLY

Copyright © 2003 ATSG

Figure 39

ZF-4HP-22/24 MODEL "E-9", "4 SOLENOID" LOWER "FRONT" VALVE BODY

*Legend And Spring
Specifications Found
On Page 49.*

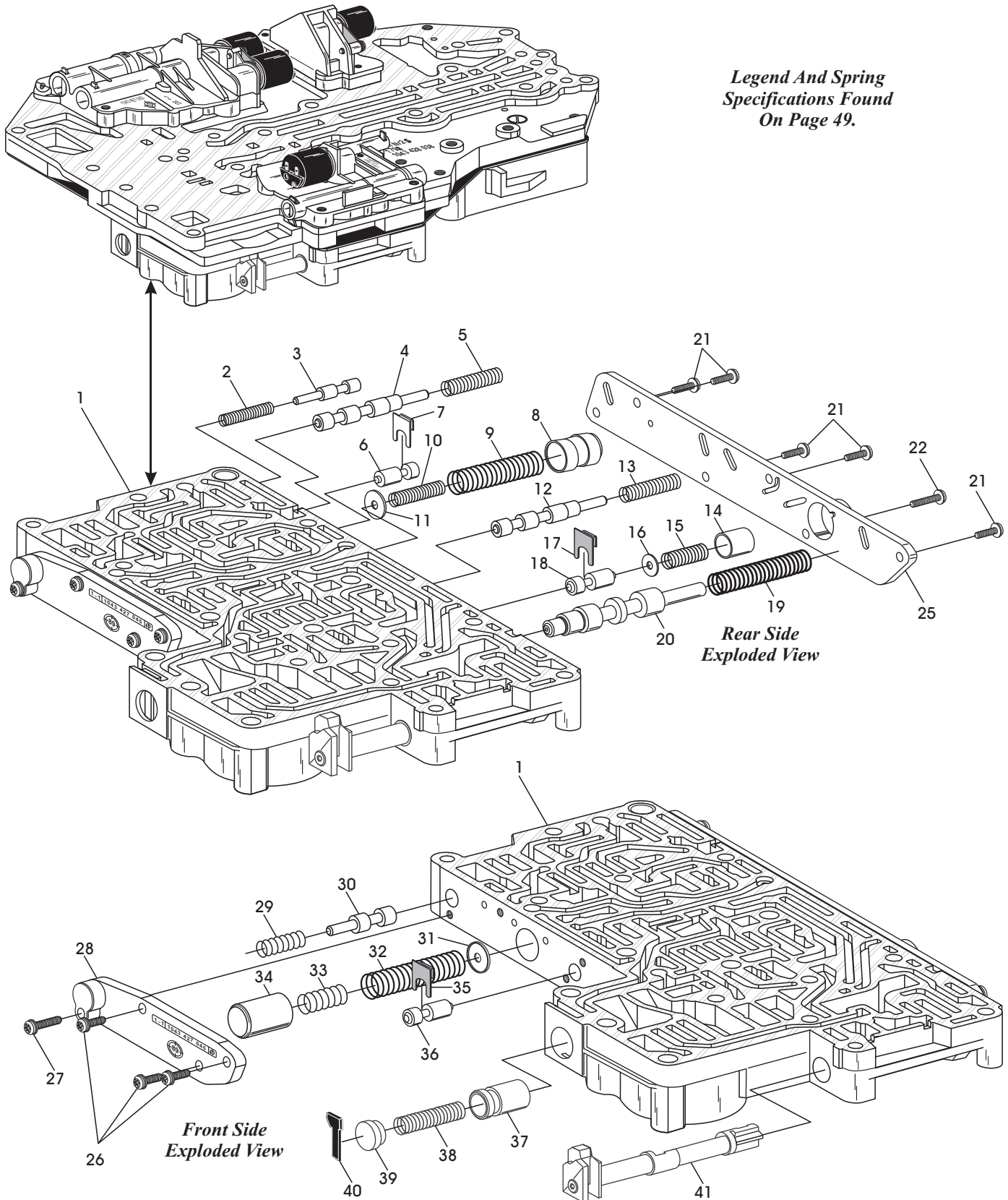

Copyright © 2003 ATSG

Figure 40

FIGURE 40 LEGEND AND SPRING SPECIFICATIONS

<p>1 LOWER FRONT VALVE BODY CASTING 2 "C" CLUTCH VALVE SPRING 3 "C" CLUTCH VALVE 4 2-3 SHIFT VALVE 5 2-3 SHIFT VALVE SPRING 6 "C" CLUTCH VALVE 7 "C" CLUTCH VALVE RETAINER 8 "B" CLUTCH DAMPER PISTON 9 "B" CLUTCH DAMPER PISTON OUTER SPRING 10 "B" CLUTCH DAMPER PISTON INNER SPRING 11 "B" CLUTCH DAMPER PISTON SPRING SEAT 12 1-2 SHIFT VALVE 13 1-2 SHIFT VALVE SPRING 14 "D" CLUTCH DAMPER PISTON 15 "D" CLUTCH DAMPER PISTON SPRING 16 "D" CLUTCH DAMPER PISTON SPRING SEAT 17 "D" CLUTCH VALVE RETAINER 18 "D" CLUTCH VALVE 19 PRESSURE REGULATOR VALVE SPRING 20 PRESSURE REGULATOR VALVE 21 REAR SIDE COVER RETAINING BOLT, 17 mm LENGTH (5) 22 REAR SIDE COVER RETAINING BOLT, 24 mm LENGTH (1) 25 REAR SIDE COVER 26 FRONT SIDE COVER RETAINING BOLT, 17 mm LENGTH (3) 27 FRONT SIDE COVER RETAINING BOLT, 29 mm LENGTH (1) 28 FRONT SIDE COVER 29 TORQUE CONVERTER LOCK-UP VALVE SPRING 30 TORQUE CONVERTER LOCK-UP VALVE 31 "C" CLUTCH DAMPER PISTON SPRING SEAT 32 "C" CLUTCH DAMPER PISTON OUTER SPRING 33 "C" CLUTCH DAMPER PISTON INNER SPRING 34 "C" CLUTCH DAMPER PISTON 35 "B" CLUTCH REGULATOR VALVE RETAINER 36 "B" CLUTCH REGULATOR VALVE</p>	<p>37 "A" CLUTCH DAMPER PISTON 38 "A" CLUTCH DAMPER SPRING 39 "A" CLUTCH DAMPER PISTON SPRING SEAT 40 "A" CLUTCH DAMPER SPRING SEAT RETAINER 41 MANUAL SHIFT VALVE</p> <p>SPRING ILLUSTRATION NO. 2: FREE LENGTH = 1.075" SPRING DIAMETER = .280" WIRE DIAMETER = .033"</p> <p>SPRING ILLUSTRATION NO. 5: FREE LENGTH = 1.925" SPRING DIAMETER = .363" WIRE DIAMETER = .033"</p> <p>SPRING ILLUSTRATION NO. 9: FREE LENGTH = 2.900" SPRING DIAMETER = .594" WIRE DIAMETER = .040"</p> <p>SPRING ILLUSTRATION NO. 10: FREE LENGTH = 1.580" SPRING DIAMETER = .432" WIRE DIAMETER = .040"</p> <p>SPRING ILLUSTRATION NO. 13: FREE LENGTH = 1.880" SPRING DIAMETER = .367" WIRE DIAMETER = .032"</p> <p>SPRING ILLUSTRATION NO. 15: FREE LENGTH = 1.655" SPRING DIAMETER = .560" WIRE DIAMETER = .045"</p> <p>SPRING ILLUSTRATION NO. 19: FREE LENGTH = 3.625" SPRING DIAMETER = .600" WIRE DIAMETER = .080"</p> <p>SPRING ILLUSTRATION NO. 29: FREE LENGTH = 1.690" SPRING DIAMETER = .443" WIRE DIAMETER = .032"</p> <p>SPRING ILLUSTRATION NO. 32: FREE LENGTH = 3.310" SPRING DIAMETER = .585" WIRE DIAMETER = .045"</p> <p>SPRING ILLUSTRATION NO. 33: FREE LENGTH = 1.590" SPRING DIAMETER = .442" WIRE DIAMETER = .032"</p> <p>SPRING ILLUSTRATION NO. 38: FREE LENGTH = 2.727" SPRING DIAMETER = .400" WIRE DIAMETER = .050"</p>
--	--

Figure 40 Legend

**ZF-4HP-22/24 MODEL "E-9", "4 SOLENOID"
 LOWER "REAR" VALVE BODY**

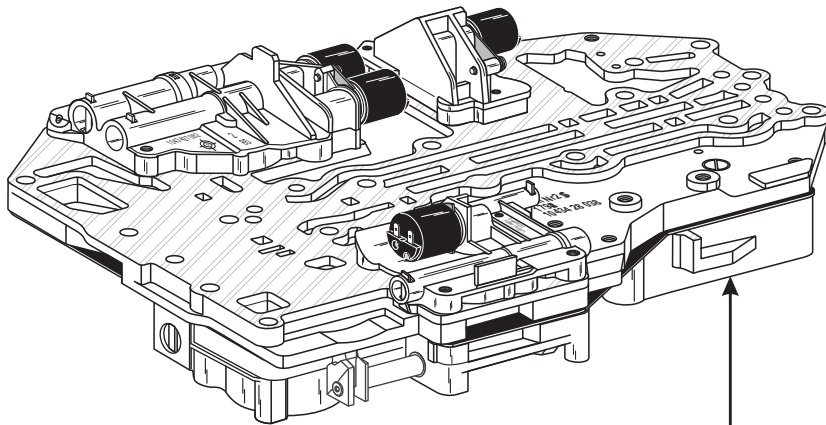

*Legend And Spring
 Specifications Found
 On Page 51.*

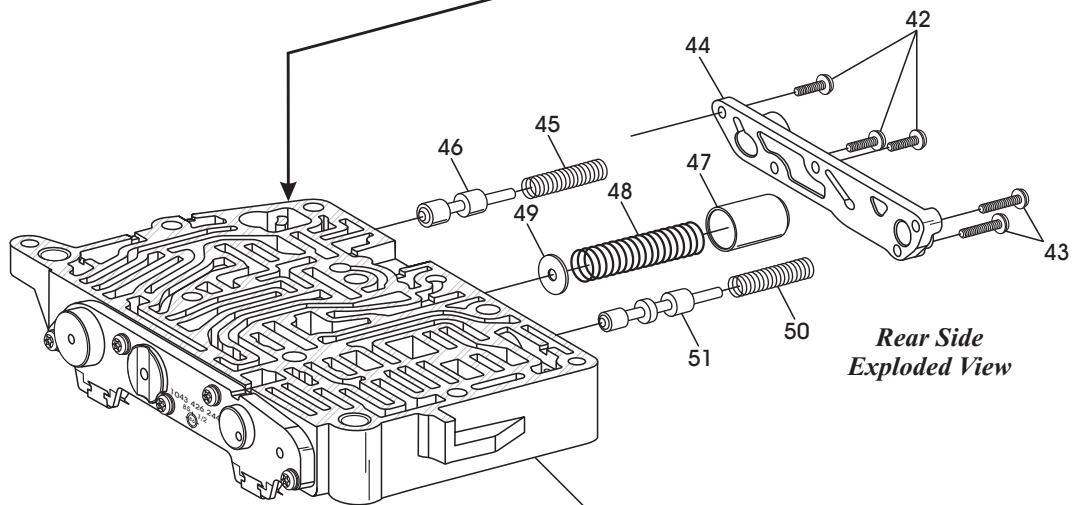

*Rear Side
 Exploded View*

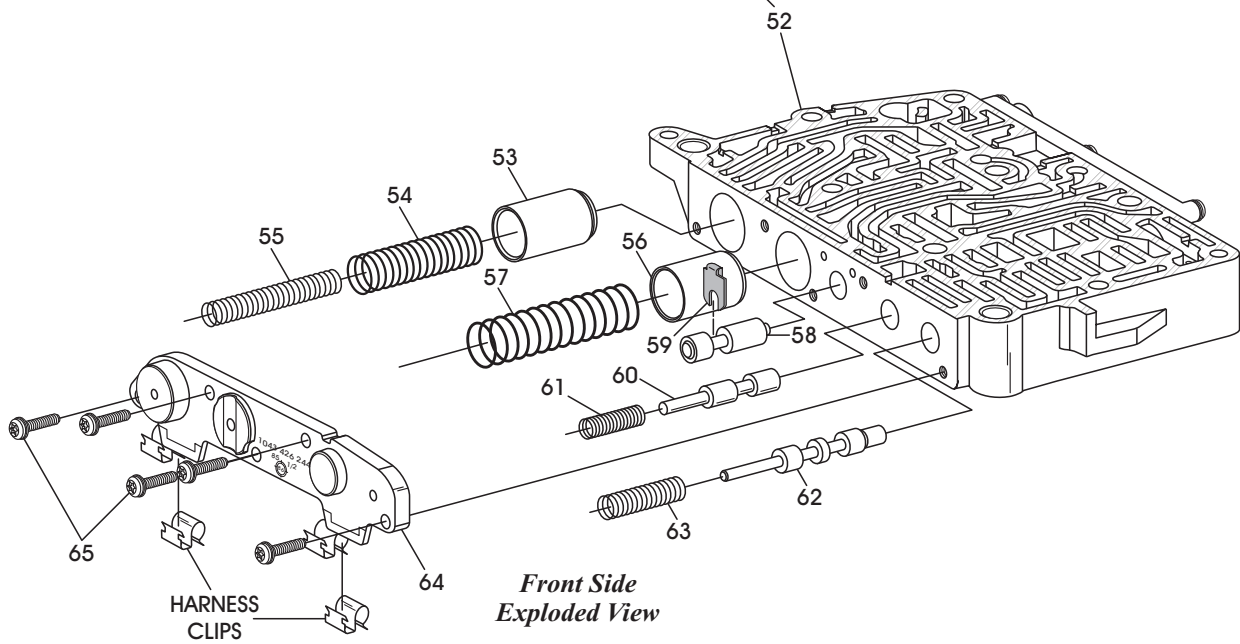

*Front Side
 Exploded View*

Figure 41



TECHNICIANS DIAGNOSTIC GUIDE

BMW, AUDI, PORSCHE

FIGURE 41 LEGEND AND SPRING SPECIFICATIONS

42 REAR SIDE COVER RETAINING BOLTS, 17 mm LENGTH (3)		
43 REAR SIDE COVER RETAINING BOLTS, 21 mm LENGTH (2)		
44 REAR SIDE COVER		
45 PRESSURE REDUCING VALVE "1" SPRING	SPRING ILLUSTRATION NO. 45:	SPRING ILLUSTRATION NO. 55:
46 PRESSURE REDUCING VALVE "1"	FREE LENGTH = 1.395"	FREE LENGTH = 3.490"
47 "F" CLUTCH DAMPER PISTON	SPRING DIAMETER = .305"	SPRING DIAMETER = .408"
48 "F" CLUTCH DAMPER PISTON SPRING	WIRE DIAMETER = .040"	WIRE DIAMETER = .045"
49 "F" CLUTCH DAMPER PISTON SPRING SEAT		
50 SAFETY VALVE SPRING	SPRING ILLUSTRATION NO. 48:	SPRING ILLUSTRATION NO. 57:
51 SAFETY VALVE	FREE LENGTH = 3.160"	FREE LENGTH = 2.905"
52 LOWER REAR VALVE BODY CASTING	SPRING DIAMETER = .690"	SPRING DIAMETER = .614"
53 "C" CLUTCH DAMPER PISTON	WIRE DIAMETER = .044"	WIRE DIAMETER = .065"
54 "C" CLUTCH DAMPER PISTON OUTER SPRING		
55 "C" CLUTCH DAMPER PISTON INNER SPRING	SPRING ILLUSTRATION NO. 50:	SPRING ILLUSTRATION NO. 61:
56 "E" CLUTCH DAMPER PISTON	FREE LENGTH = 1.267"	FREE LENGTH = 1.515"
57 "E" CLUTCH DAMPER PISTON SPRING	SPRING DIAMETER = .315"	SPRING DIAMETER = .339"
58 "F" CLUTCH VALVE	WIRE DIAMETER = .025"	WIRE DIAMETER = .045"
59 "F" CLUTCH VALVE RETAINER		
60 PRESSURE REDUCING VALVE "2"	SPRING ILLUSTRATION NO. 54:	SPRING ILLUSTRATION NO. 63:
61 PRESSURE REDUCING VALVE "2" SPRING	FREE LENGTH = 2.900"	FREE LENGTH = 1.595"
62 3-4 SHIFT VALVE	SPRING DIAMETER = .603"	SPRING DIAMETER = .67"
63 3-4 SHIFT VALVE SPRING	WIRE DIAMETER = .065"	WIRE DIAMETER = .032"
64 FRONT SIDE COVER		
65 FRONT SIDE COVER RETAINING BOLTS, 17 mm LENGTH (5)		

Copyright © 2003 ATSG

Figure 41 Legend

ZF-4HP-22/24 MODEL "E-9", "4 SOLENOID" MV-5 SOLENOID BODY

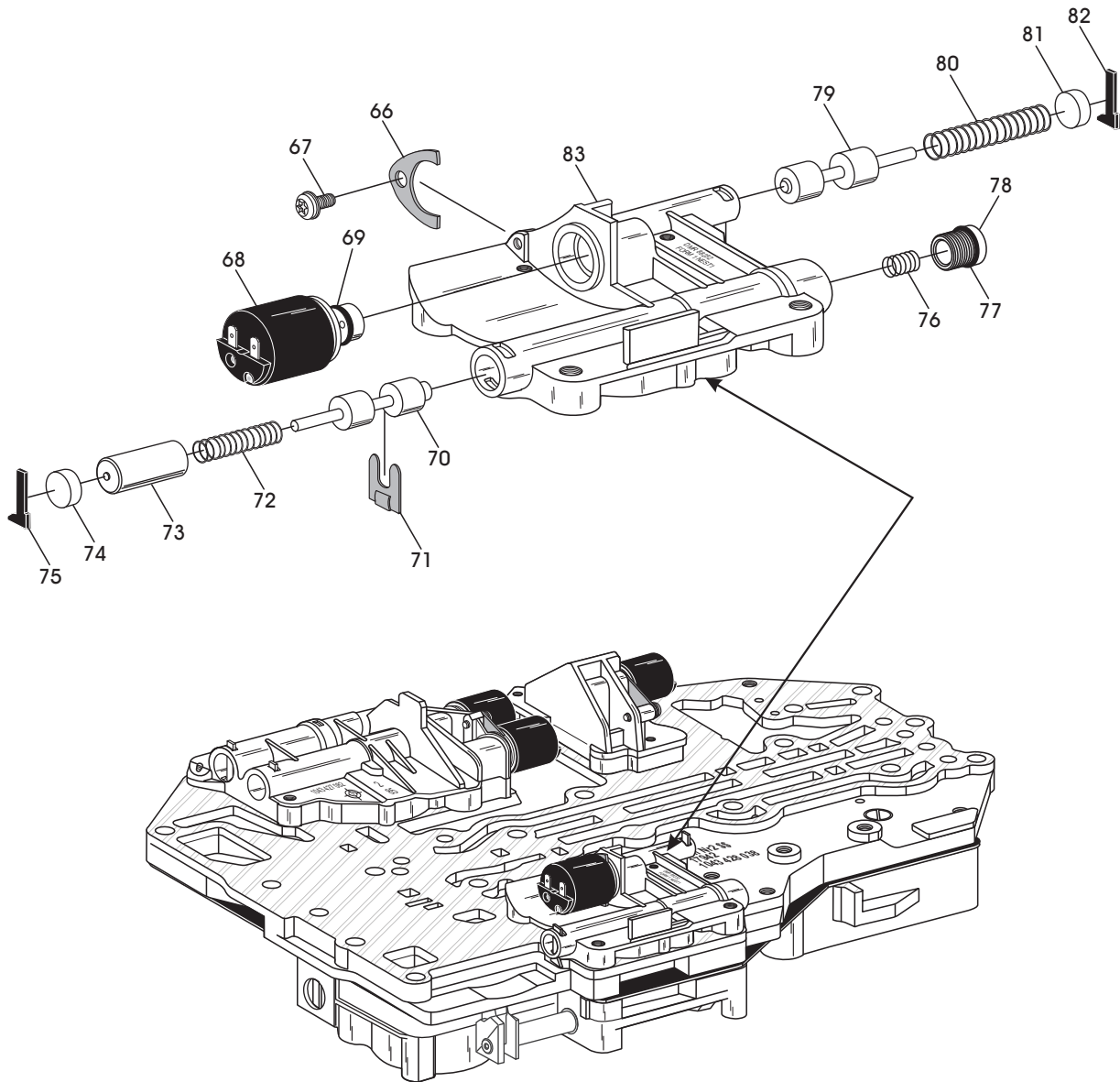

- 66 SOLENOID RETAINING BRACKET
- 67 SOLENOID RETAINING BOLT, 11 mm LENGTH
- 68 MV-5 LINE PRESSURE SOLENOID ASSEMBLY
- 69 MV-5 LINE PRESSURE SOLENOID "O" RING
- 70 MODULATION VALVE
- 71 MODULATION VALVE RETAINER
- 72 MODULATION VALVE SPRING
- 73 MODULATION VALVE SPRING SLEEVE
- 74 MODULATION VALVE BORE PLUG
- 75 MODULATION VALVE BORE PLUG RETAINER
- 76 MODULATION VALVE BALANCE SPRING
- 77 MODULATION VALVE ADJUSTING PLUG "O" RING
- 78 MODULATION VALVE ADJUSTING PLUG
- 79 REVERSE LOCKOUT VALVE
- 80 REVERSE LOCKOUT VALVE SPRING
- 81 REVERSE LOCKOUT VALVE BORE PLUG
- 82 REVERSE LOCKOUT VALVE BORE PLUG RETAINER
- 83 MV-5 SOLENOID BODY CASTING

SPRING ILLUSTRATION NO. 72:
 FREE LENGTH = 1.245"
 SPRING DIAMETER = .302"
 WIRE DIAMETER = .039"

SPRING ILLUSTRATION NO. 76:
 FREE LENGTH = .770"
 SPRING DIAMETER = .377"
 WIRE DIAMETER = .027"

SPRING ILLUSTRATION NO. 80:
 FREE LENGTH = 1.835"
 SPRING DIAMETER = .380"
 WIRE DIAMETER = .035"

Copyright © 2003 ATSG

Figure 42

**ZF-4HP-22/24 MODEL "E-9", "4 SOLENOID"
MV-1 AND MV-2 SOLENOID BODY**

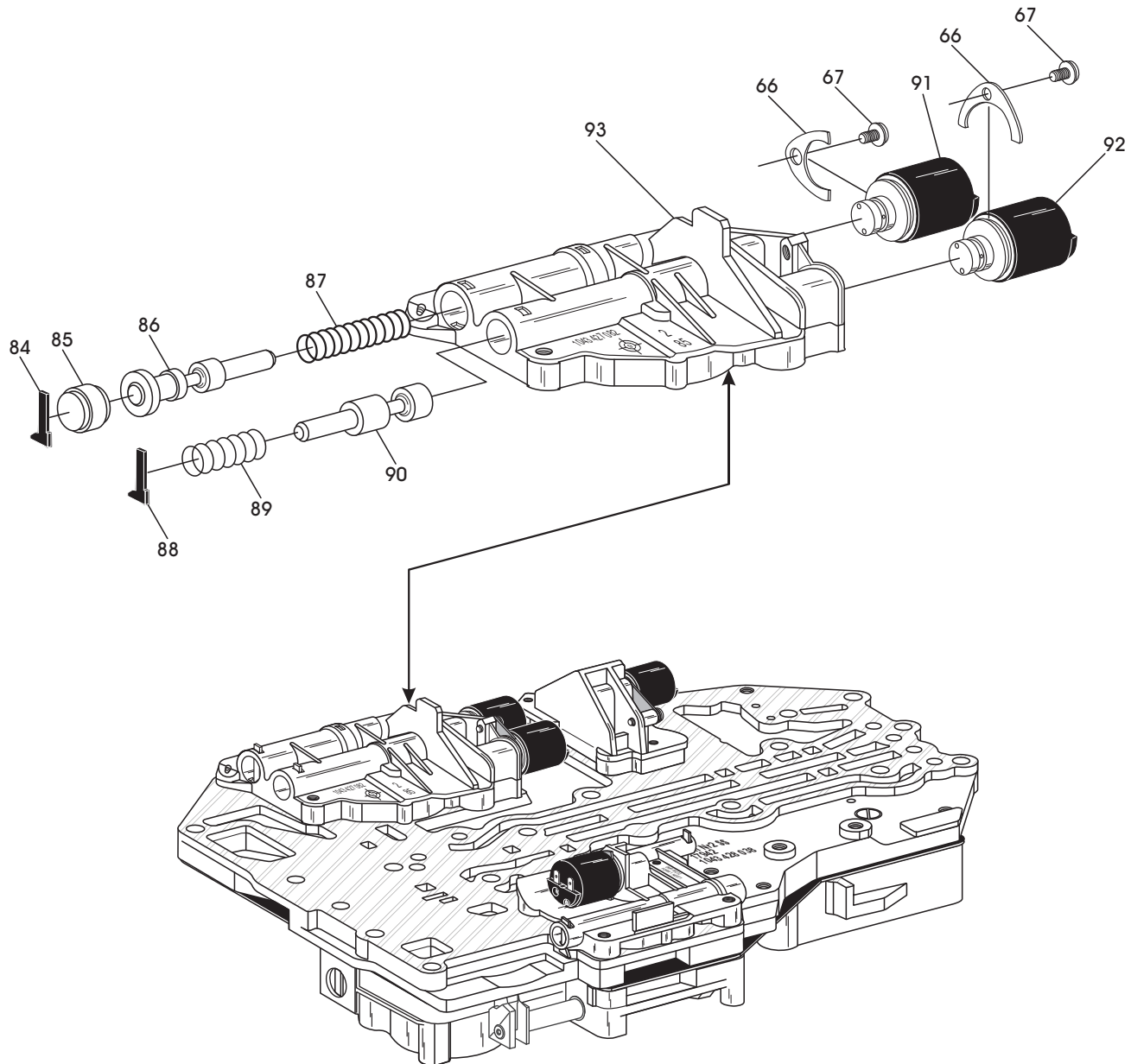

- 66 SOLENOID RETAINING BRACKET
- 67 SOLENOID RETAINING BOLT, 11 mm LENGTH
- 84 T.C.C. VALVE BORE PLUG RETAINER
- 85 T.C.C. VALVE BORE PLUG
- 86 TORQUE CONVERTER CLUTCH VALVE
- 87 TORQUE CONVERTER CLUTCH VALVE SPRING
- 88 LUBRICATION VALVE SPRING RETAINER
- 89 LUBRICATION VALVE SPRING
- 90 LUBRICATION VALVE
- 91 MV-2 SHIFT SOLENOID ASSEMBLY
- 92 MV-1 SHIFT SOLENOID ASSEMBLY
- 93 SHIFT SOLENOID BODY CASTING

SPRING ILLUSTRATION NO. 87:
FREE LENGTH = 1.570"
SPRING DIAMETER = .430"
WIRE DIAMETER = .039"

SPRING ILLUSTRATION NO. 89:
FREE LENGTH = 1.545"
SPRING DIAMETER = .440"
WIRE DIAMETER = .031"

Copyright © 2003 ATSG

Figure 43

**ZF-4HP-22/24 MODEL "E-9", "4 SOLENOID"
MV-3 SOLENOID BODY**

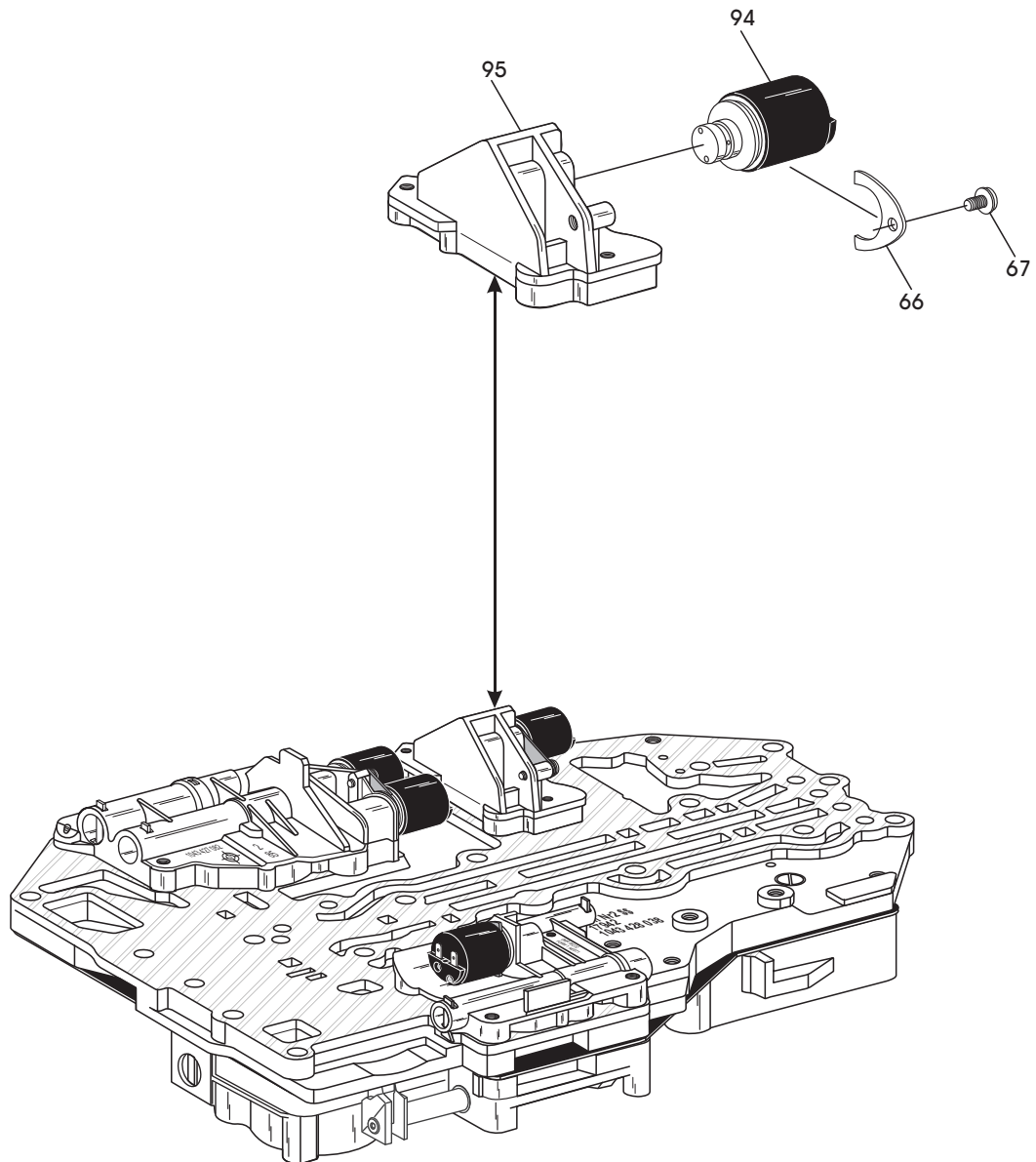

- 66 SOLENOID RETAINING BRACKET
- 67 SOLENOID RETAINING BOLT, 11 mm LENGTH
- 94 MV-3 LOCK-UP SOLENOID ASSEMBLY
- 95 MV-3 SOLENOID BODY CASTING

Copyright © 2003 ATSG

Figure 44

**ZF-4HP-22/24 MODEL "E-9", "4 SOLENOID"
LOWER "FRONT" VALVE BODY**

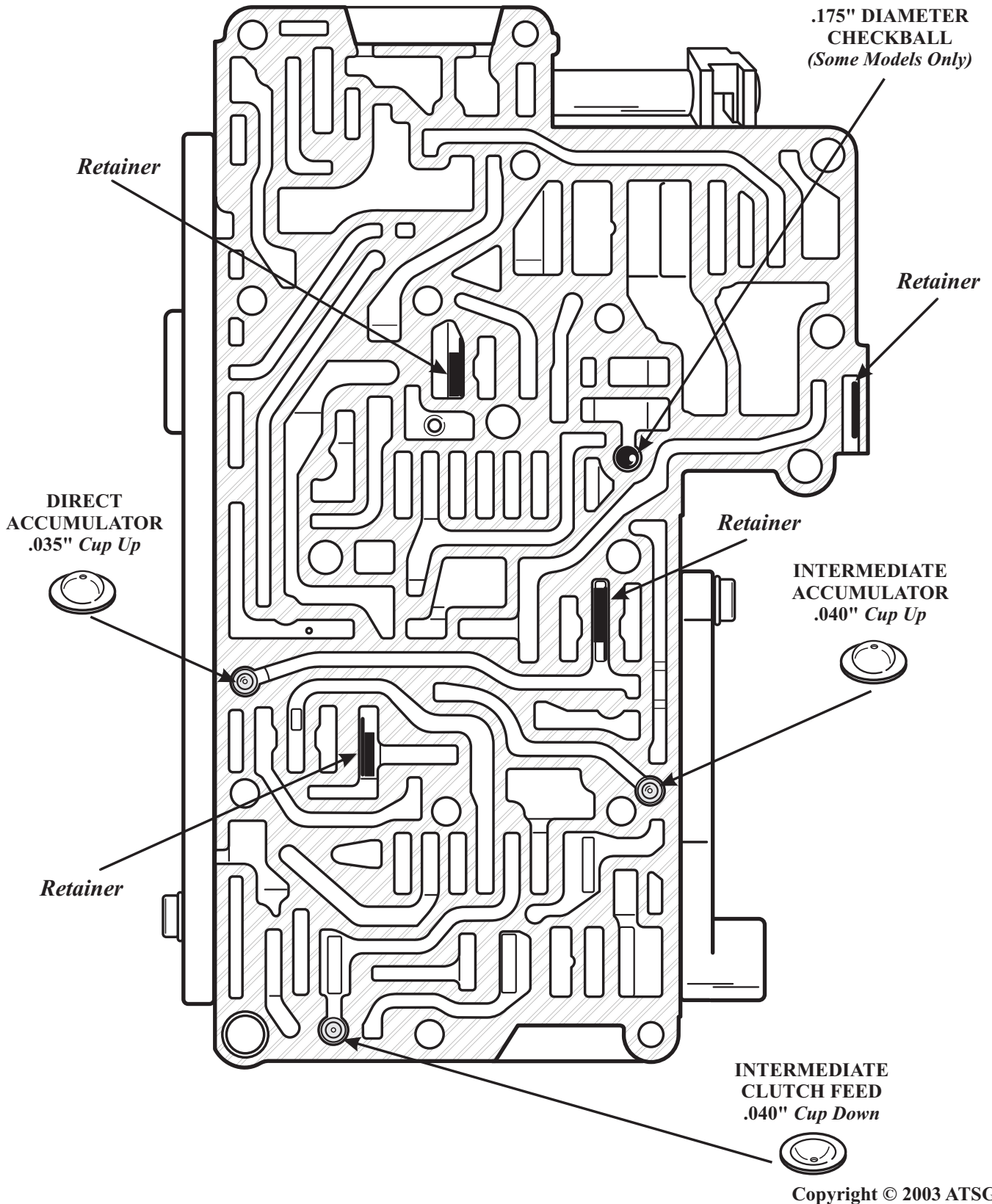
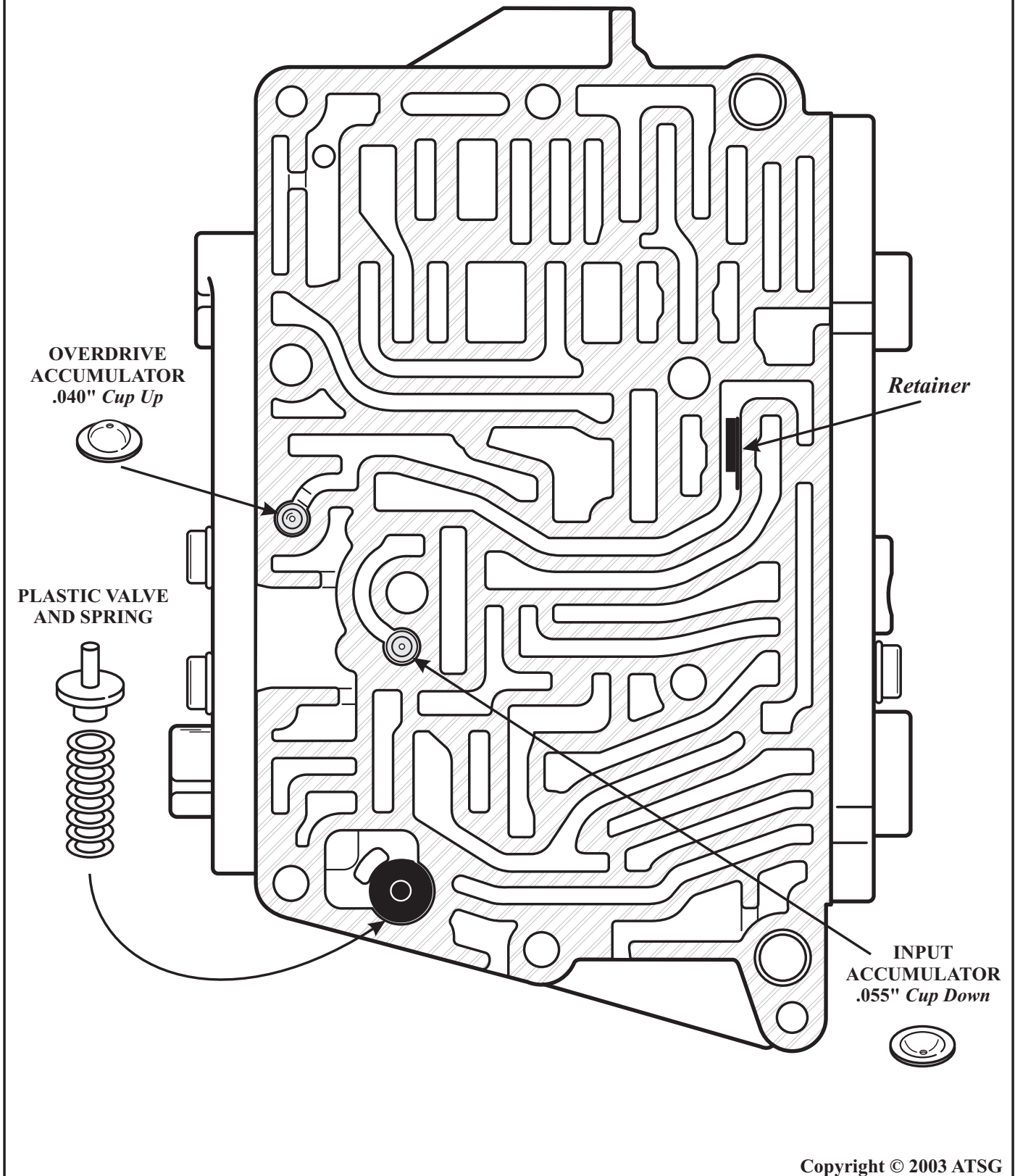

Figure 45

**ZF-4HP-22/24 MODEL "E-9", "4 SOLENOID"
LOWER "REAR" VALVE BODY**



Copyright © 2003 ATSG

Figure 46

**ZF-4HP-22/24 MODEL "E-9", "4 SOLENOID"
CHANNEL PLATE**

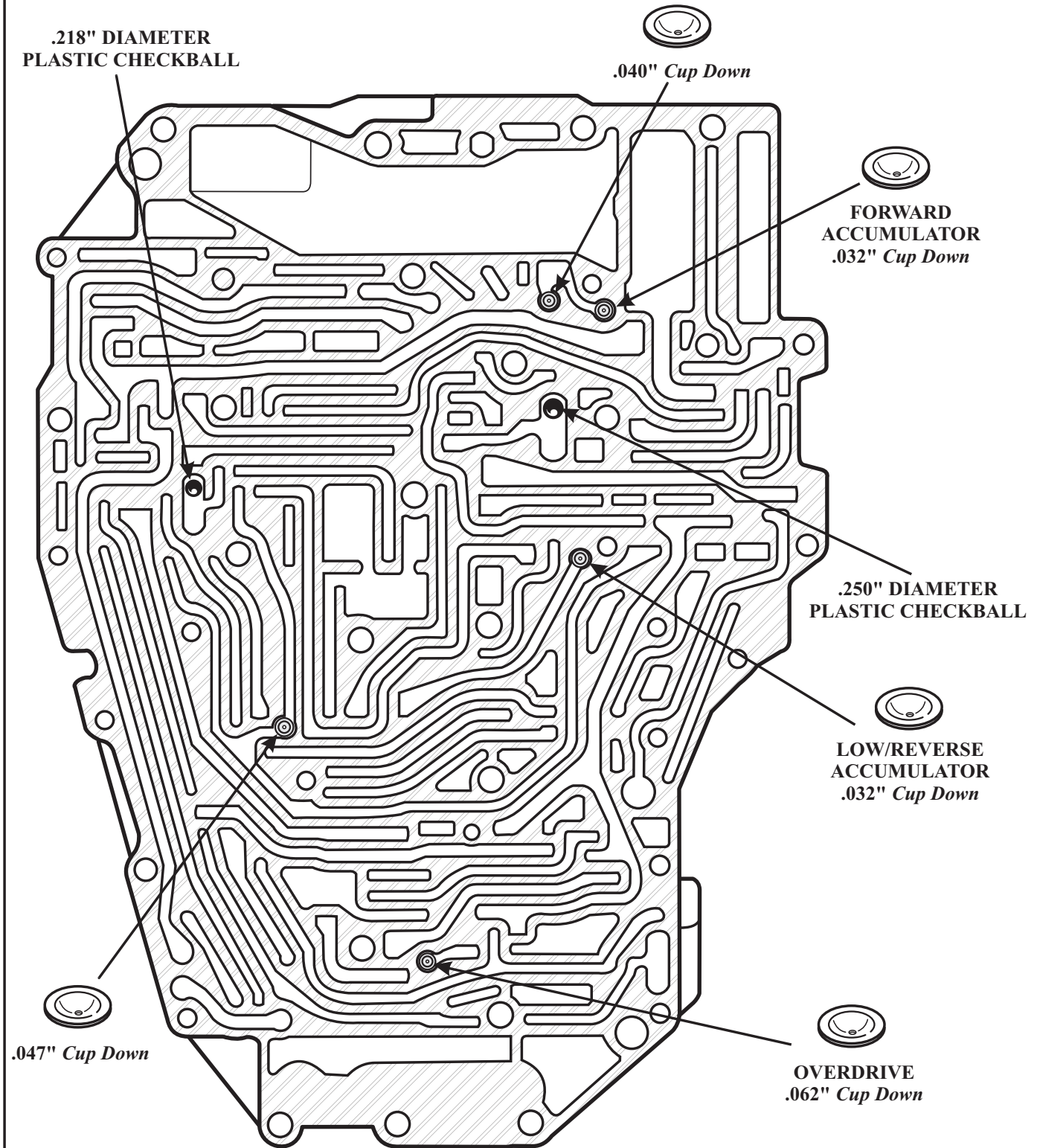

Copyright © 2003 ATSG

Figure 47

**ZF-4HP-22/24 MODEL "E-9", "4 SOLENOID"
ALL SOLENOID BODIES**

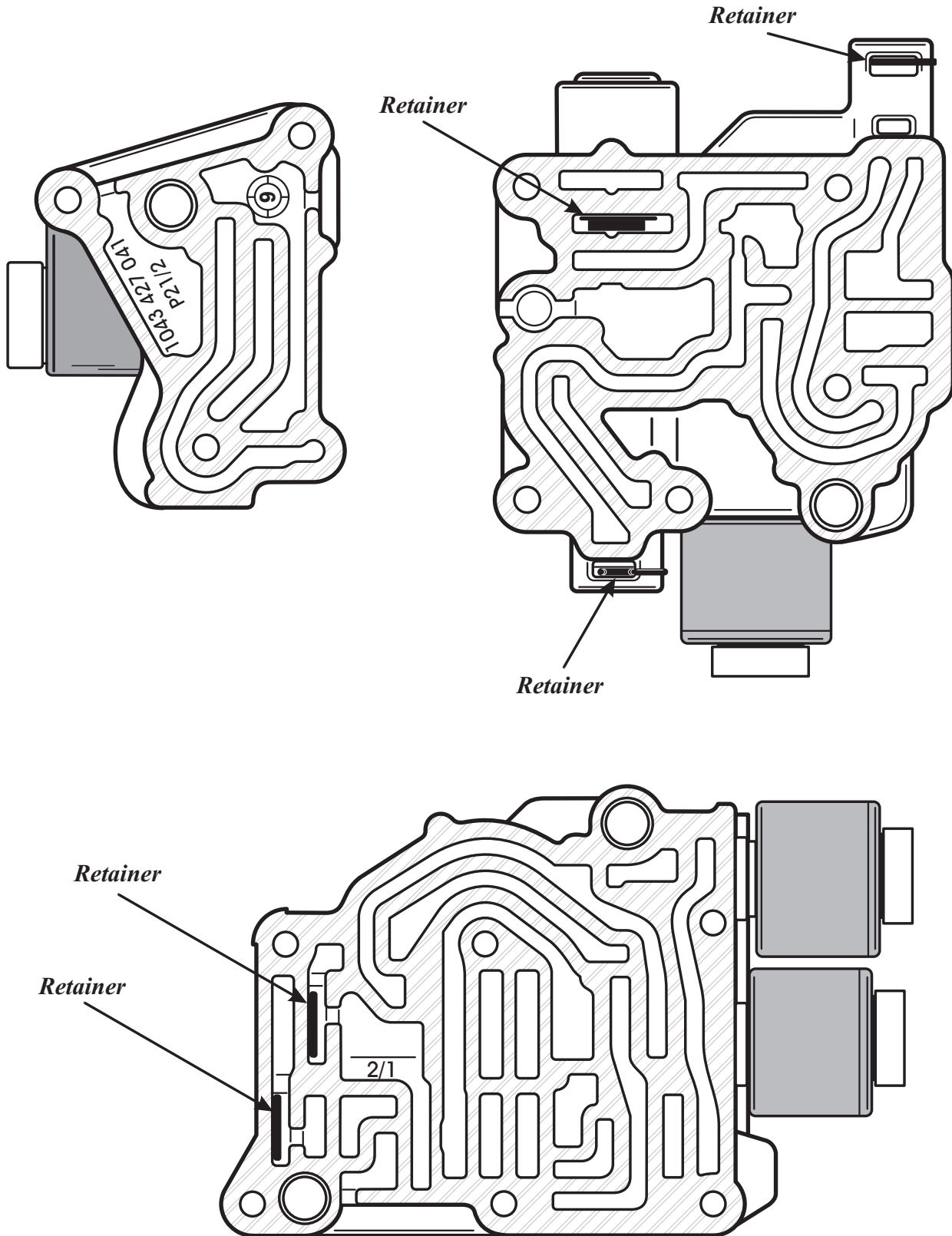

Copyright © 2003 ATSG

Figure 48

BMW ZF-5HP-18
DIAGNOSTIC INFORMATION

FOUND IN:

93-94 320i 3.0LV/8
 93-95 530i 3.0LV/8
 95-98 M3 3.0L/3.2LL6
 730 3.0LV/8

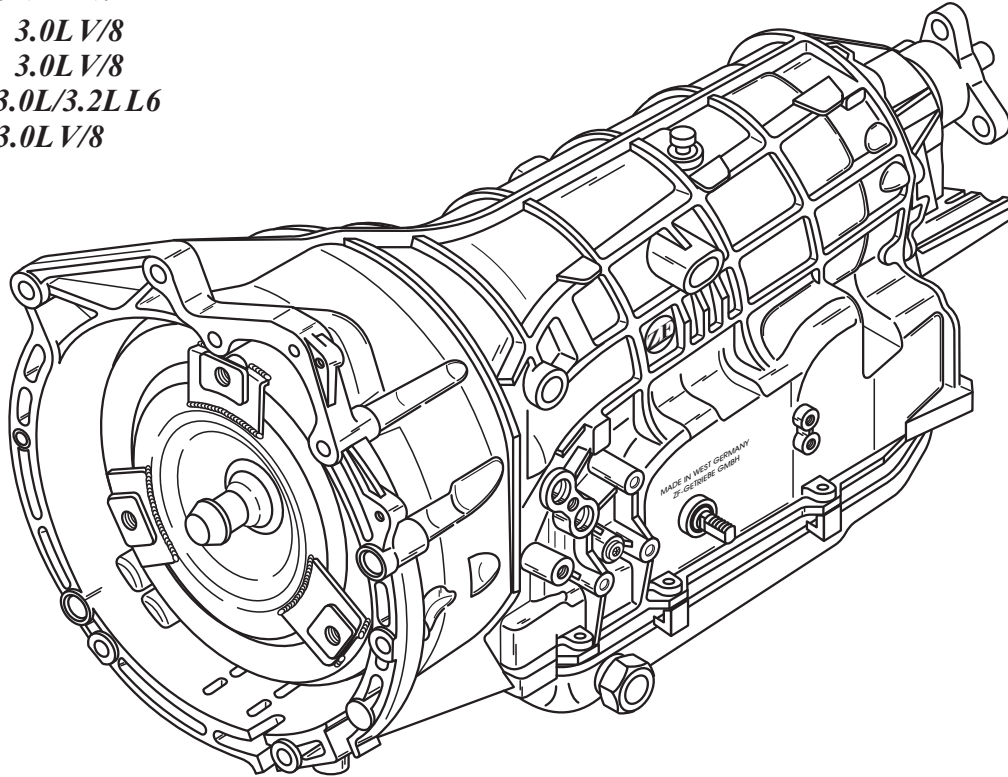

This transmission is manufactured in Germany by ZF and carries the BMW designation A5S 310Z.

The A5S 310Z (ZF-5HP-18) is an electronically controlled, five speed automatic transmission with a lock-up clutch type torque converter. Two planetary gear sets, one Ravigneaux gear set and one standard planetary gear set on the output side, four rotating multiple disc clutches, three multiple disc brake clutches, one brake band, and two sprag clutches (Freewheels) are used to provide the five forward speeds and reverse.

Key to designation:

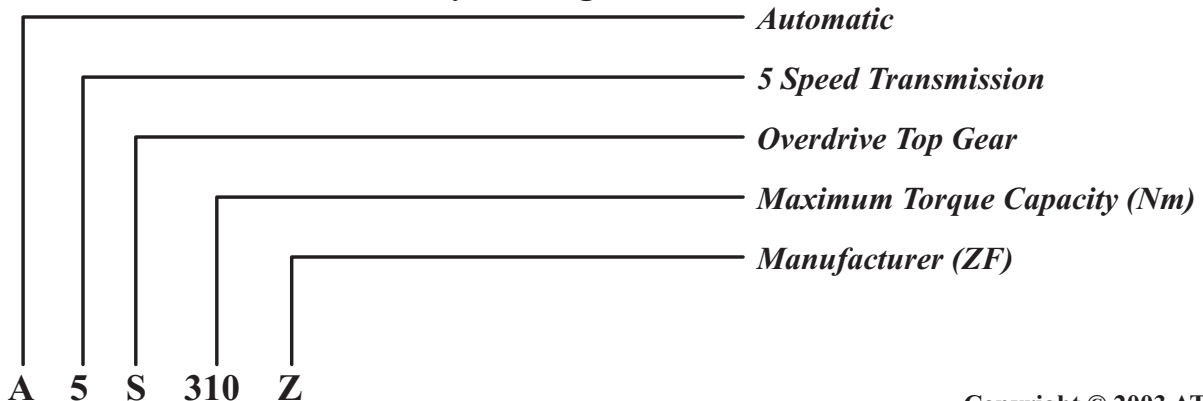

Copyright © 2003 ATSG

Figure 49



TECHNICIANS DIAGNOSTIC GUIDE

BMW, AUDI, PORSCHE

Refer to Figure 50 for Clutch and Band Application Chart.

Refer to Figure 51 for Manual Shift Lever Operation, Mode Switch Operation and location, and Failsafe Operation.

Refer to Figure 52 for both MV Solenoid Operation and EDS Solenoid Operation and Tests.

Refer to Figure 53 for Shift Solenoid Application chart and their locations. Notice that the MV 6 Solenoid is used only for Converter Clutch application and that it is identified by a White connector on the solenoid, where all the others are Black. Notice also that EDS 1 Solenoid is used for line pressure control. MV 4 and MV 5 Solenoids are used only for downshifts.

Refer to Figure 54 for wiring harness identification, internal wiring schematic, and transmission case connector pin identification and functions.

Refer to Figure 55 for identification and internal component resistance chart.

Refer to Figure 56 and 57 for retrieving trouble codes and the Trouble Code charts.

Refer to Figure 58 for Solenoid and Sensor resistance chart with the pins identified for both the case connector and the Transmission Control Unit connector.

Refer to Figure 59 for case passage identification to air check this unit before installation of the valve body assembly.

Refer to Figure 60 for pressure tap locations on the case, and notice that some cases you must drill and tap for access to a particular pressure.

Refer to Figure 61 for exploded view of the Upper Front Valve Body with valves identified.

Refer to Figure 62 for speed sensor locations on the channel plate.

Refer to Figure 63 for exploded view of the Solenoid Valve Body with valves identified. Notice that there is an "O" ring on the adjustment screw that goes in the groove.

Refer to Figure 64 for exploded view of the Lower Rear Valve Body with the valves identified.

Refer to Figure 65 for exploded view of the Lower Front Valve Body with the valves identified.

Refer to Figures 66 thru 69 for the retaining clip locations in the various valve bodies.

Refer to Figure 70 for the locations of the orifices, checkballs, screens, and the check valves and springs that are located in the channel plate.

Refer to Figure 71 for all valve body spring specifications, as observed in a used valve body.

Refer to Page 83 for "No Movement Or Delayed Engagement", and Refer to Page 86 for a "Bind-Up In 1st Gear, With Selector Lever In Manual 2 Position".

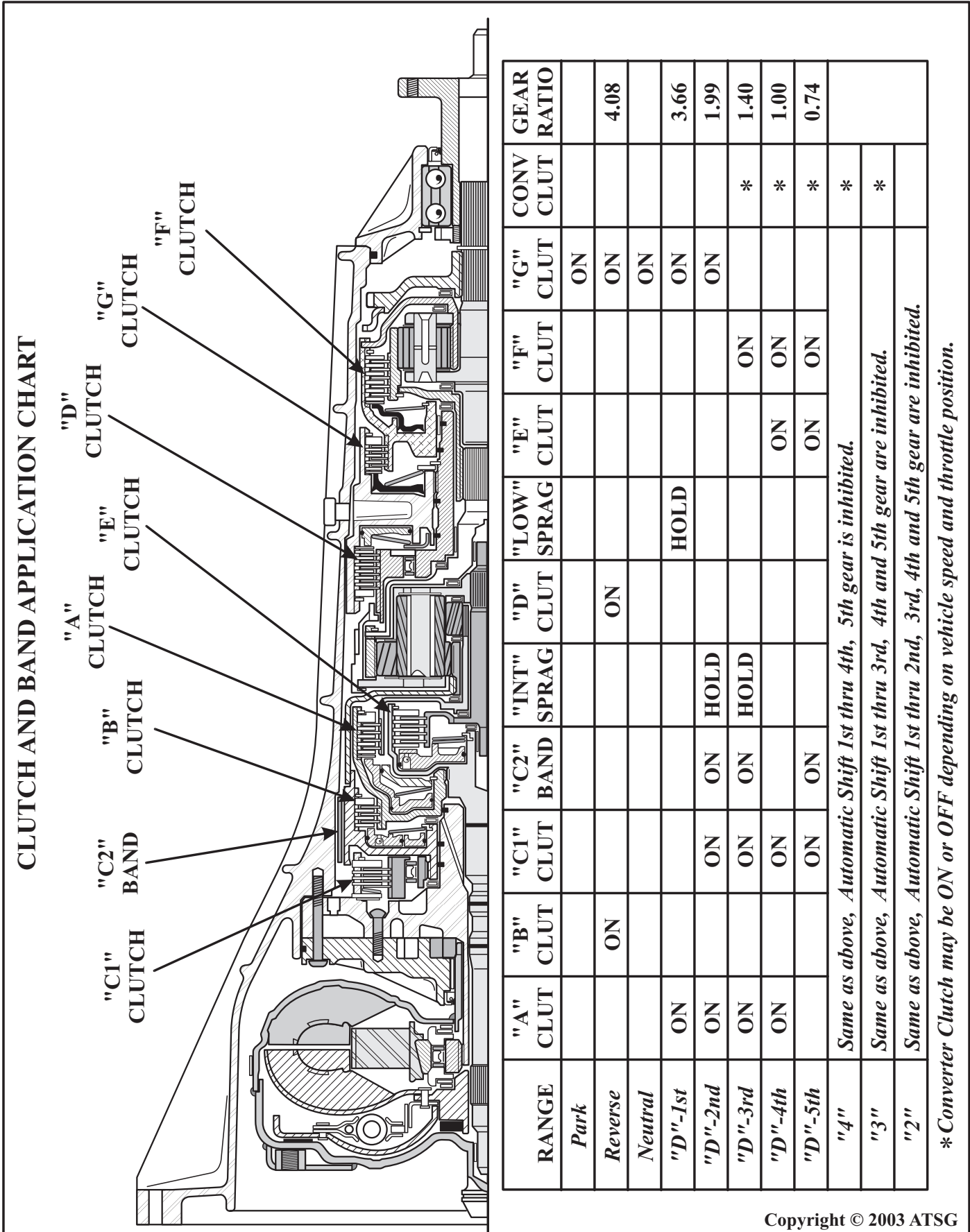

Copyright © 2003 ATSG

Figure 50

SELECTOR LEVER

- P** = Park
- R** = Reverse
- N** = Neutral
- D** = Automatic Shift 1st thru 5th gear.
- 4** = Automatic Shift 1st thru 4th gear.
5th gear is locked out.
- 3** = Automatic Shift 1st thru 3rd gear.
4th and 5th gear are locked out.
- 2** = Automatic Shift 1st thru 2nd gear.
3rd, 4th and 5th gear are locked out.

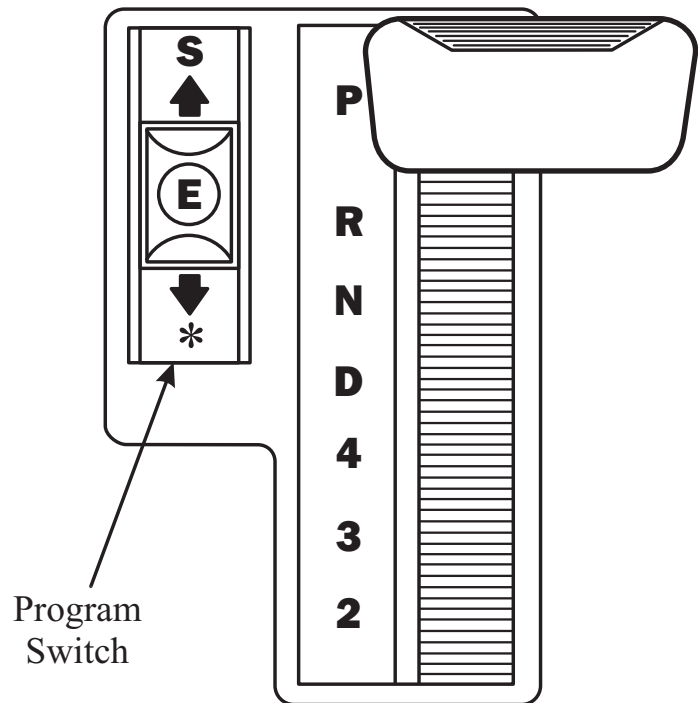

The "Program Switch" can be used to select one of three programs.

E = **ECONOMY (Fuel Efficient Driving Style)**

The "E" program is activated every time the engine is started. Once the engine has been started, either Sport or Winter programs can be selected with the Program Switch. The transmission changes automatically from 1st thru 5th gear in any throttle position up to full throttle. When throttle position is in the kick-down range, the transmission changes automatically from 1st thru 4th gears. The change into 5th gear is a forced upshift and occurs just before engine speed reaches the upper limit for controlled cut-back.

S = **SPORT (Full Exploitation of Engine Performance)**

The "S" program is performance oriented and must be re-selected every time the engine is started. The transmission changes automatically from 1st thru 4th gear regardless of throttle position. The change into 5th gear is a forced upshift and occurs just before engine speed reaches the upper limit for controlled cut-back.

***** = **WINTER (Manual Shifts)**

The "Winter" program provides manual shifts and is designed for situations of driving on snow or ice, driving on mountain roads or towing a trailer. The driver has the same free choice of gears as with a manual transmission, as the transmission remains in the gear selected with the selector lever. This makes it possible to utilize the engines full braking power. The transmission never changes into 1st or 5th gears in the "Winter" mode.

FAILSAFE OPERATION:

When a system fault is detected which would impair normal reliable operation, the transmission control module interrupts the power supply to Pin 13 at the transmission case connector. The transmission control module also alerts the driver of any faults by signaling the vehicles "Check Control" system. To enable the vehicle to be driven to a repair shop, the following manual gear selections are permitted:

<i>Selector Lever Position</i>	P R N D 4 3 2
<i>Actual Gear Obtained</i>	P R N 4 4 4 4

Copyright © 2003 ATSG

Figure 51

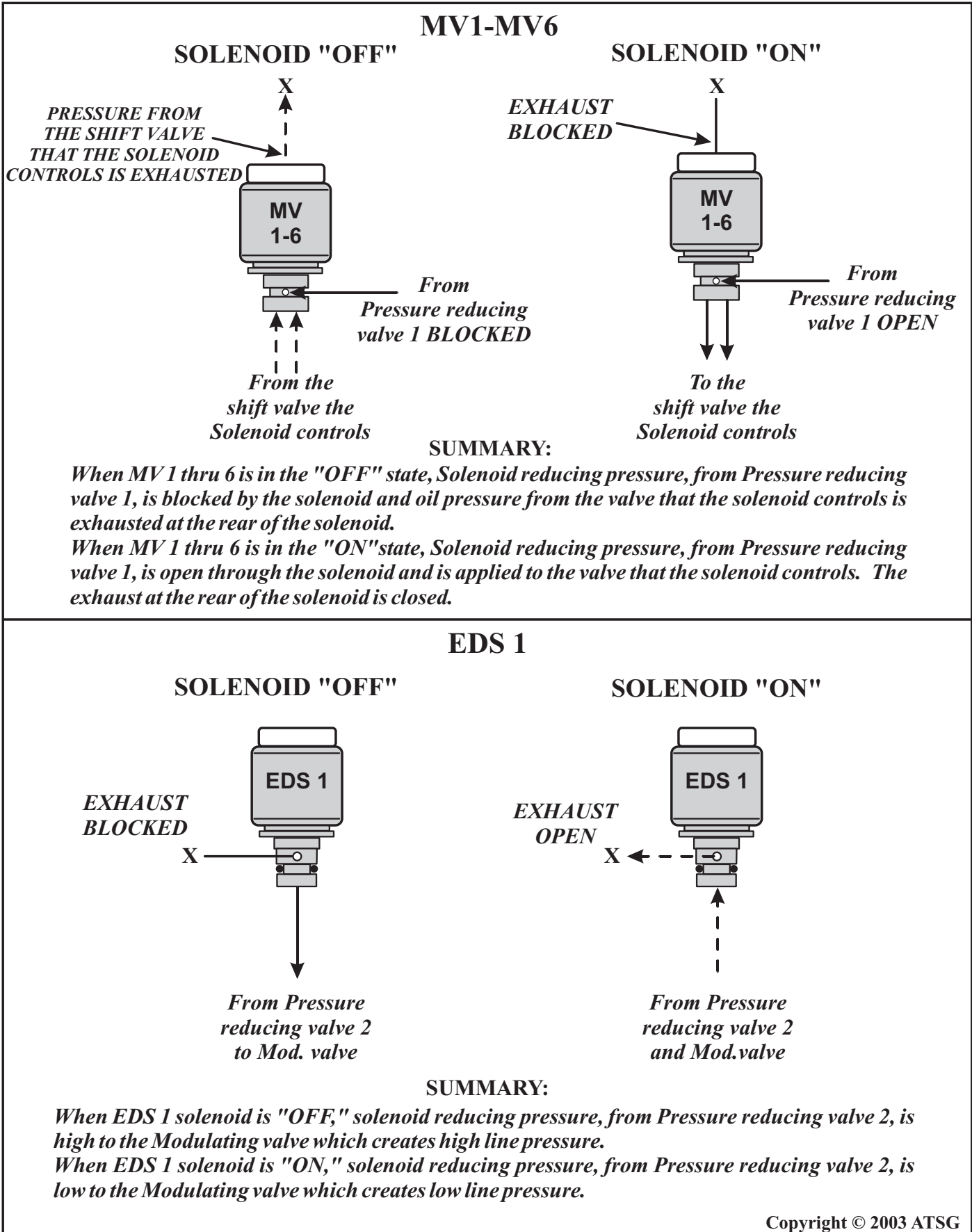
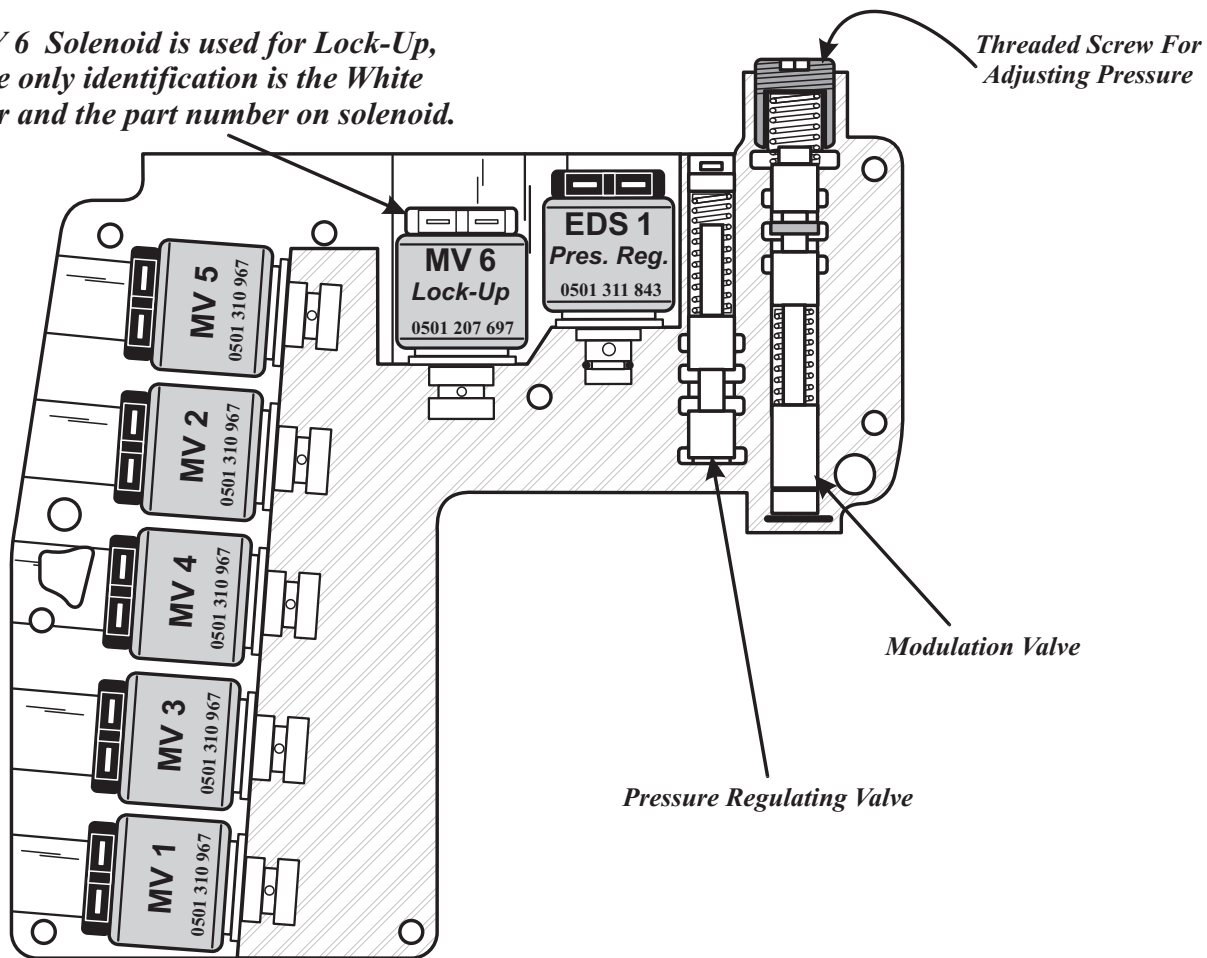

Figure 52

The MV 6 Solenoid is used for Lock-Up, and the only identification is the White connector and the part number on solenoid.



RANGE	SHIFT SOLENOID APPLICATION CHART							RATIO	
	MV 1	MV 2	MV 3	MV 4	MV 5	MV 6	EDS 1		
<i>Park</i>	ON	ON	ON				**		
<i>Reverse</i>	ON	ON					**	4.08	
<i>Neutral</i>	ON	ON	ON				**		
<i>"D"-1st</i>	ON	ON	ON				**	3.66	
<i>"D"-2nd</i>		ON	ON				**	1.99	
<i>"D"-3rd</i>			ON			*	**	1.40	
<i>"D"-4th</i>							*	**	1.00
<i>"D"-5th</i>	ON						*	**	0.74
<i>"D", 3-2</i>				ON			**		
<i>"D", 5-4</i>					ON		**		
<i>"Failsafe"</i>	OFF	OFF	OFF	OFF	OFF	OFF	OFF	1.00	

* Converter Clutch may be ON or OFF depending on vehicle speed and throttle position.

** Line Pressure is Modulating, depending on vehicle speed and throttle position.

Note: MV 4 and MV 5 are used only on downshifts.

Copyright © 2003 ATSG

Figure 53

ZF-5HP-18 INTERNAL WIRE SCHEMATIC

*View Looking Into Case
Connector Setting In The vehicle*

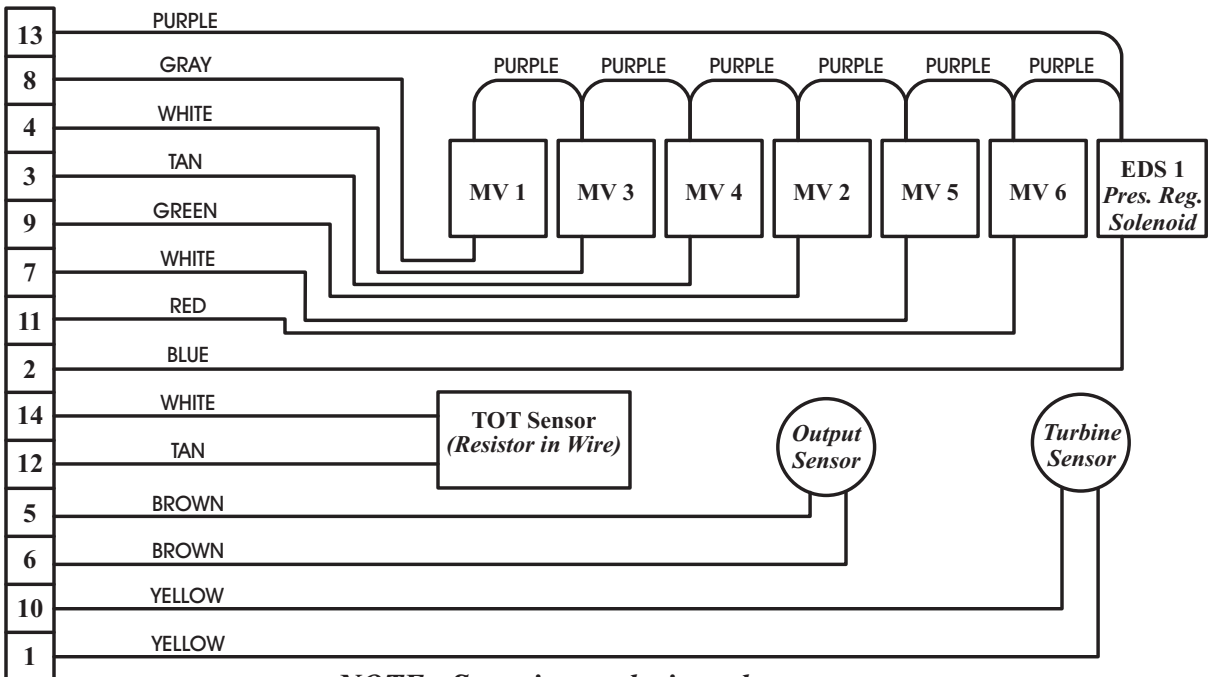
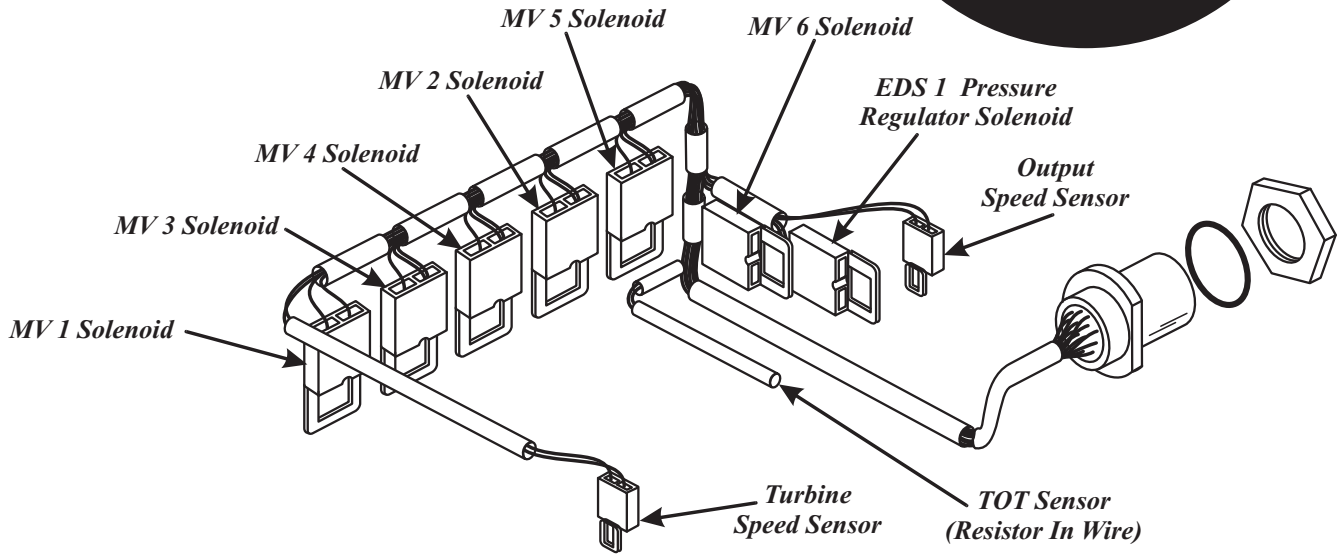
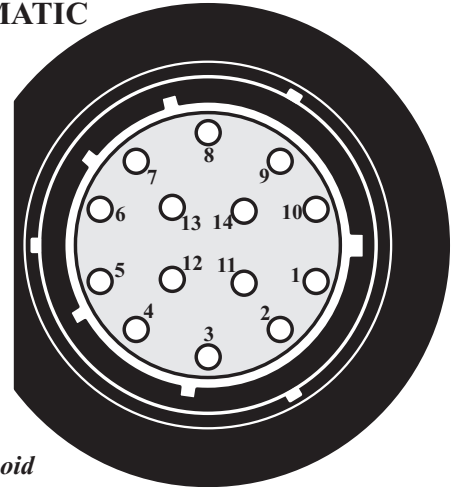

NOTE: Some internal wire colors may vary.

Copyright © 2003 ATSG

Figure 54

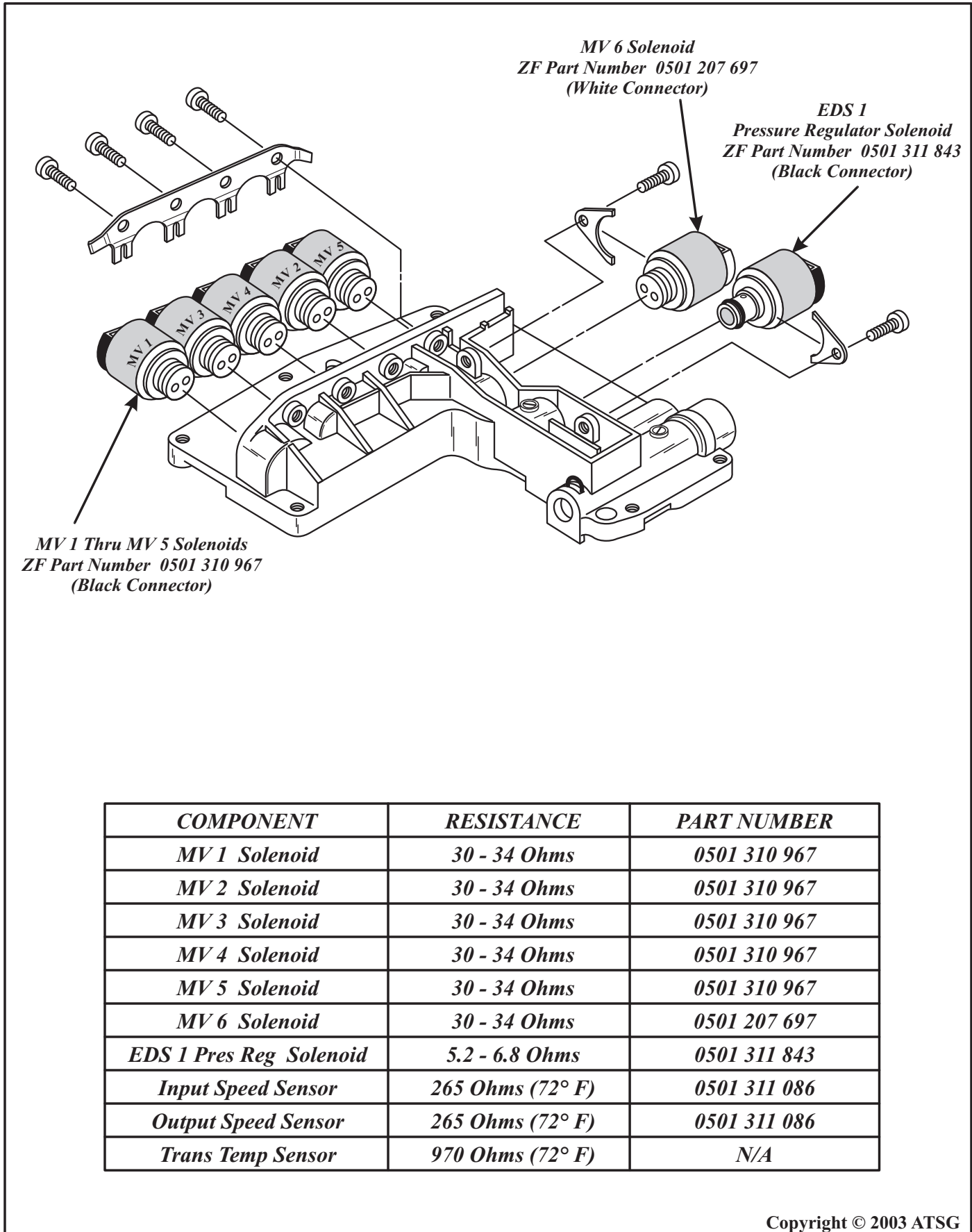

<i>COMPONENT</i>	<i>RESISTANCE</i>	<i>PART NUMBER</i>
<i>MV 1 Solenoid</i>	<i>30 - 34 Ohms</i>	<i>0501 310 967</i>
<i>MV 2 Solenoid</i>	<i>30 - 34 Ohms</i>	<i>0501 310 967</i>
<i>MV 3 Solenoid</i>	<i>30 - 34 Ohms</i>	<i>0501 310 967</i>
<i>MV 4 Solenoid</i>	<i>30 - 34 Ohms</i>	<i>0501 310 967</i>
<i>MV 5 Solenoid</i>	<i>30 - 34 Ohms</i>	<i>0501 310 967</i>
<i>MV 6 Solenoid</i>	<i>30 - 34 Ohms</i>	<i>0501 207 697</i>
<i>EDS 1 Pres Reg Solenoid</i>	<i>5.2 - 6.8 Ohms</i>	<i>0501 311 843</i>
<i>Input Speed Sensor</i>	<i>265 Ohms (72° F)</i>	<i>0501 311 086</i>
<i>Output Speed Sensor</i>	<i>265 Ohms (72° F)</i>	<i>0501 311 086</i>
<i>Trans Temp Sensor</i>	<i>970 Ohms (72° F)</i>	<i>N/A</i>

Figure 55



TECHNICIANS DIAGNOSTIC GUIDE BMW, AUDI, PORSCHE

RETRIEVING FAULT CODES

The BMW Diagnostic Tool is *required* to retrieve the fault codes that are stored in the control unit. The diagnostic tool has the ability to retrieve codes, clear codes and activate individual components, and is adaptable to 3 Series, 5 Series, 7 Series and 8 Series vehicles equipped with 4HP-22/24, 4L30-E, 5HP-18, 5HP-19, and 5HP-30.

BMW ZF-5HP-18 FAULT CODE CHART

<i>Code</i>	<i>Description (Pin No's Refer To TCM)</i>	<i>Possible Causes</i>
02	Park-Neutral Lock Solenoid - Pin 2	Break or short in wiring, or defective solenoid
03	MV 5 Solenoid - Pin 3	Break or short in wiring, or defective solenoid
04	MV 6 Solenoid (Lock-Up) - Pin 4	Break or short in wiring, or defective solenoid
05	EDS 1 Solenoid (Pres. Reg.) - Pin 5	Break or short in wiring, or defective solenoid
08	Selector Lever Position L2 - Pin 8	Vehicle acceleration detected while selector lever in P or N position, or engine has been started even though trans control unit has not detected a selector lever position of P or N
09	Selector Lever Position L3/L4 - Pins 37 and 9	Engine has been started even though trans control unit has not detected a selector lever position of P or N
0C	Program Selector Switch - Pins 12, 13 and 45	Short in wiring, or more than one program selector switch input is applied to ground
10	Turbine Shaft Speed Sensor, Pins 16 and 44	No input, or incorrect engine speed information
12	Kickdown Switch - Pin 18	Shorted to Ground
13	ASC Monitoring - Pin 19	ASC operation has been detected while selector lever was in Park or Neutral position
16	TOT Sensor - Pins 21 and 22	Resistance of TOT Sensor not within permissible range
1A	Battery Voltage Supply - Pin 26	Break in wiring
1E	MV 1 Solenoid - Pin 30	Break or short in wiring, or defective winding in solenoid
1F	MV 4 Solenoid - Pin 31	Break or short in wiring, or defective winding in solenoid
20	MV 3 Solenoid - Pin 32	Break or short in wiring, or defective winding in solenoid
21	MV 2 Solenoid - Pin 33	Break or short in wiring, or defective winding in solenoid
23	Throttle Position Sensor - Pin 35	Break or short in wiring, or defective sensor
24	Selector Lever Position L1 - Pin 36	Break or short in wiring, or defective sensor
2A	Output Speed Sensor signal - Pins 13 and 42	No input, or incorrect output speed information
2b	Engine Speed Signal - Pin 43	Questionable signal, or break or short in wiring
35	Power Supply to transmission - Pin 52	Break or short in wiring, or defective TCU

Copyright © 2003 ATSG

Figure 56

BMW ZF-5HP-18 FAULT CODE CHART

Code	Description (Pin No's Refer To TCM)	Possible Causes
36	Power Supply - Pin 54	Power Supply less than 9 volts at engine speeds greater than 1600 RPM
64	Speed Monitoring	Faulty Speed Sensor signal, or slip in Transmission
65	EPROM - Checksum	Program memory in Transmission Control Unit faulty
66	Incorrect Program Checksum	Program memory in Transmission Control Unit faulty
67	Transmission Relay - Pin 52	Pickup and dropout times too long
68	Engine Temp Sensor - Pin 35	Break or Short in wiring, or defective CTS
69	Throttle Position Sensor - Pin 35	TCU detected questionable TPS signal
6E	Basic Data Record	TCU has not been programmed
96	CAN Timeout 1	CAN signal not sent during initialization (Ignition On)
97	CAN Timeout 2	CAN signal not sent during operation
98	CAN Bus monitoring	Values in CAN RAM are not updated
99	CAN status fault	Control units with different CAN statuses are installed on CAN bus
9A	CAN throttle valve information	DME detects faulty throttle valve signal
9B	CAN load signal information	DME detects faulty load signal
9C	CAN engine intervention	DME cannot carry out reduction in engine torque desire by the EGS, or DME has different requirements compared to other CAN users
9D	CAN engine temperature info	DME detects faulty engine temperature signal
9E	CAN engine speed information	DME detects faulty engine speed signal

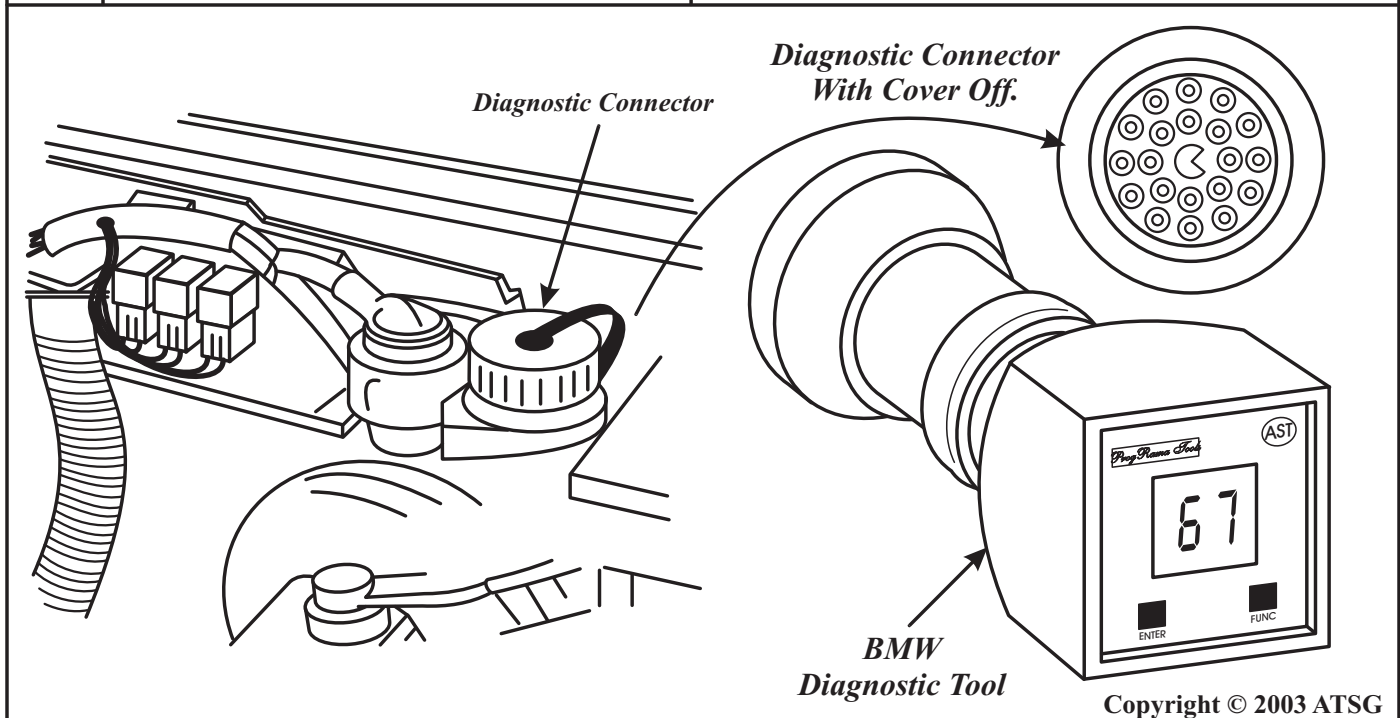

Figure 57

TECHNICIANS DIAGNOSTIC GUIDE

BMW, AUDI, PORSCHE

SOLENOID AND SENSOR RESISTANCE CHART

Solenoid	Case Connector Pin Numbers		Control Unit Connector Pin Numbers		Resistance In Ohms
	-	+	-	+	
MV 1	8	13	30	52	30 - 34 Ω
MV 2	9	13	33	52	30 - 34 Ω
MV 3	4	13	32	52	30 - 34 Ω
MV 4	3	13	31	52	30 - 34 Ω
MV 5	7	13	3	52	30 - 34 Ω
MV 6	11	13	4	52	30 - 34 Ω
EDS 1	2	13	5	52	5.2 - 6.8 Ω
TOT	12	14	21	22	970 Ω at 72°F
TSS	1	10	44	16	265 Ω (72°F)
OSS	5	6	14	42	265 Ω (72°F)

*View Looking Into Case
Connector Setting In The vehicle*

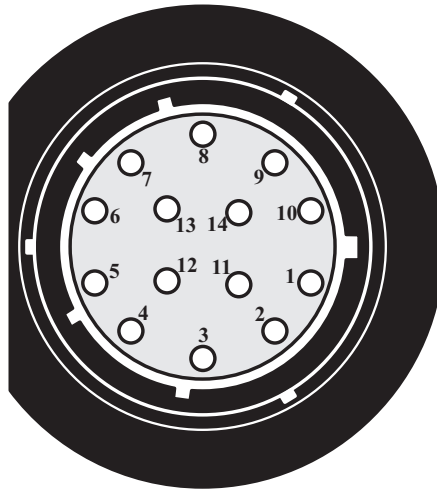

Electronic Control Unit Connector Pin Identification

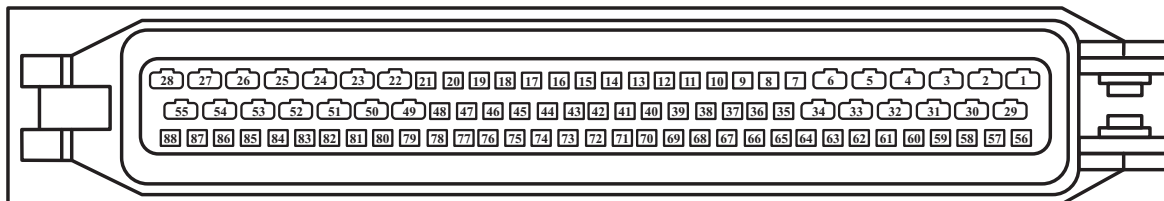

Copyright © 2003 ATSG

Figure 58

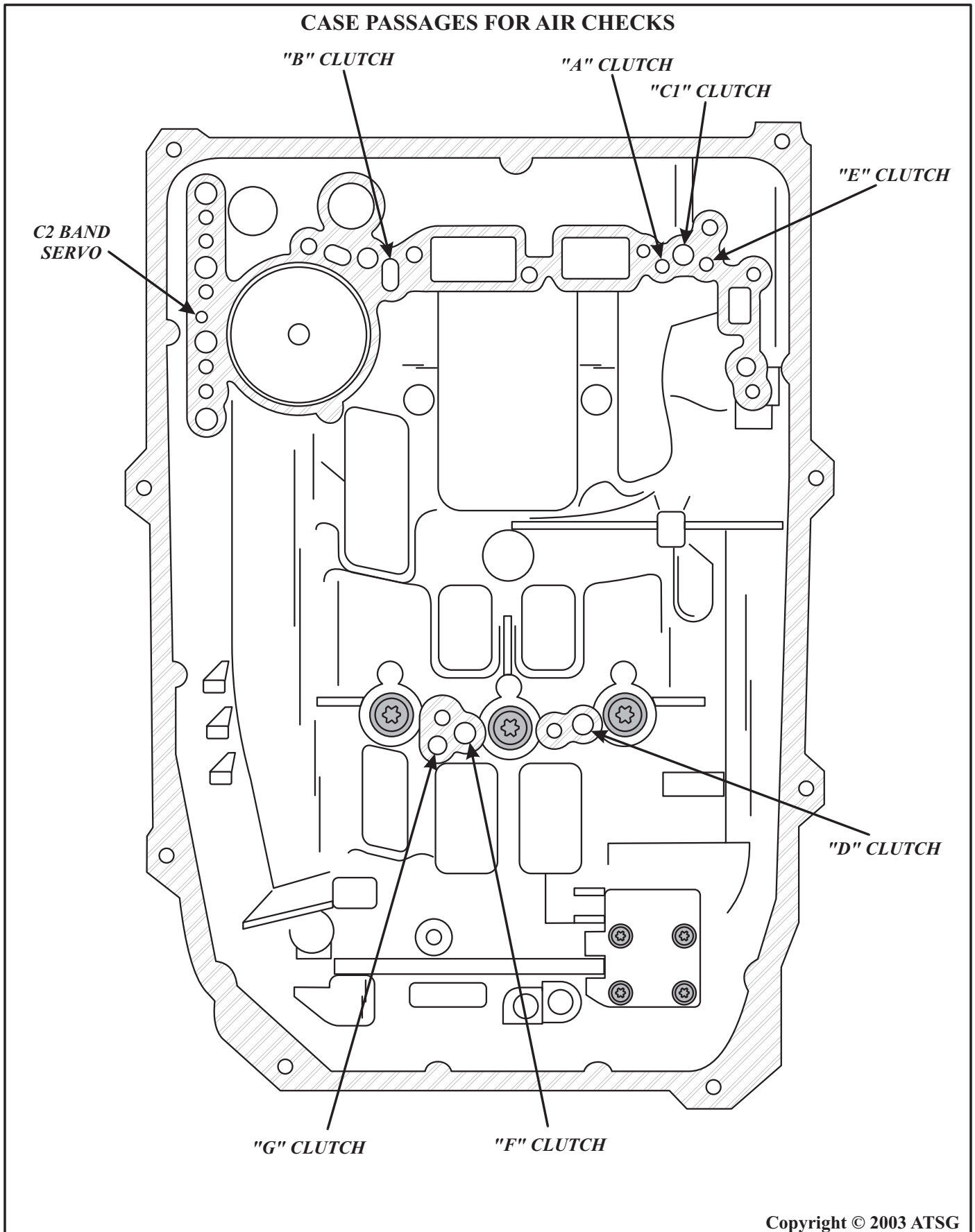

Copyright © 2003 ATSG

Figure 59

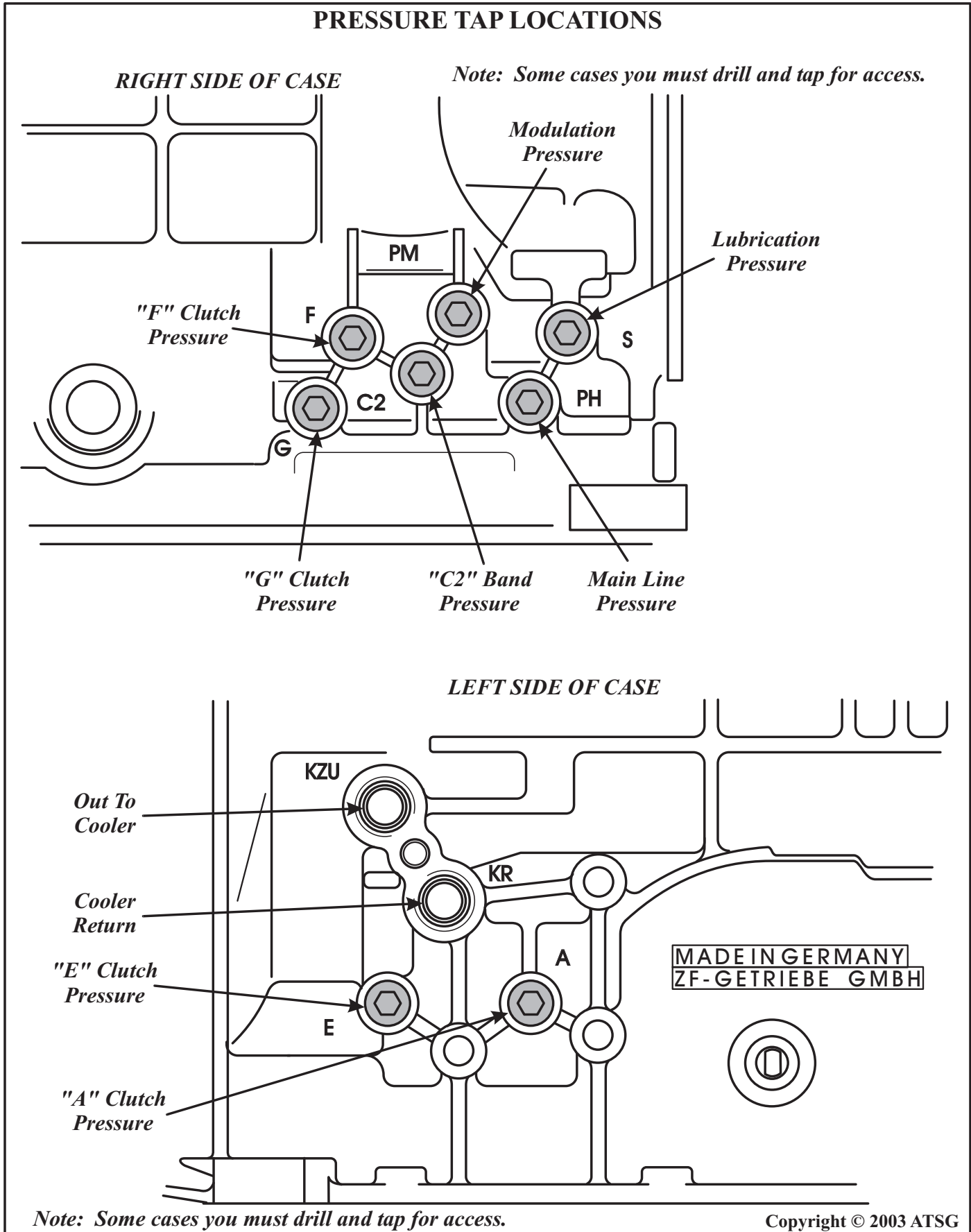
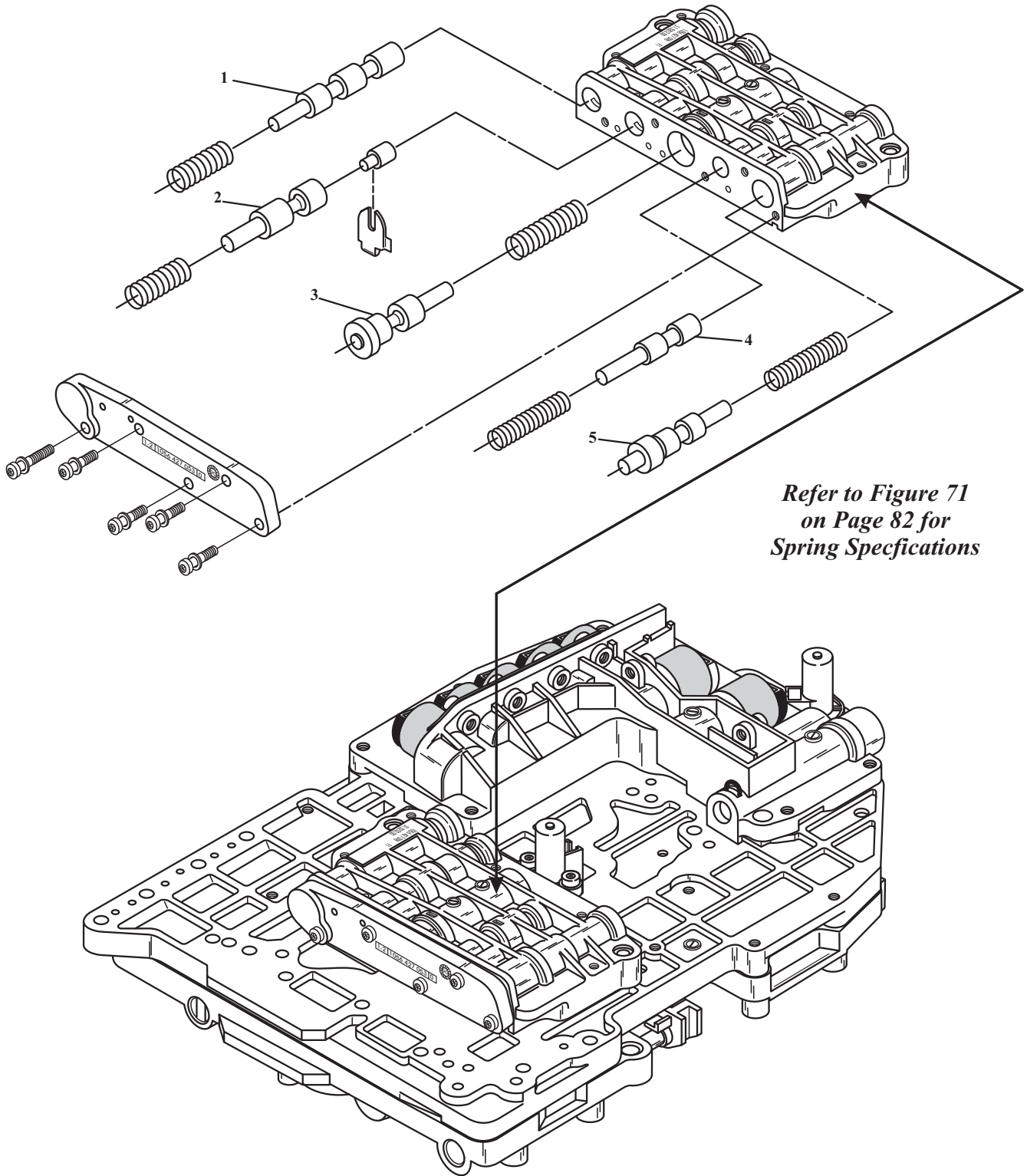

Figure 60

UPPER FRONT VALVE BODY



- 1. Torque Converter Valve
- 2. Lubrication Valve Train
- 3. Lock-Up Control Valve
- 4. 5-4 Traction Valve

Figure 61

SOLENOID BODY, SPEED SENSORS AND CHANNEL PLATE

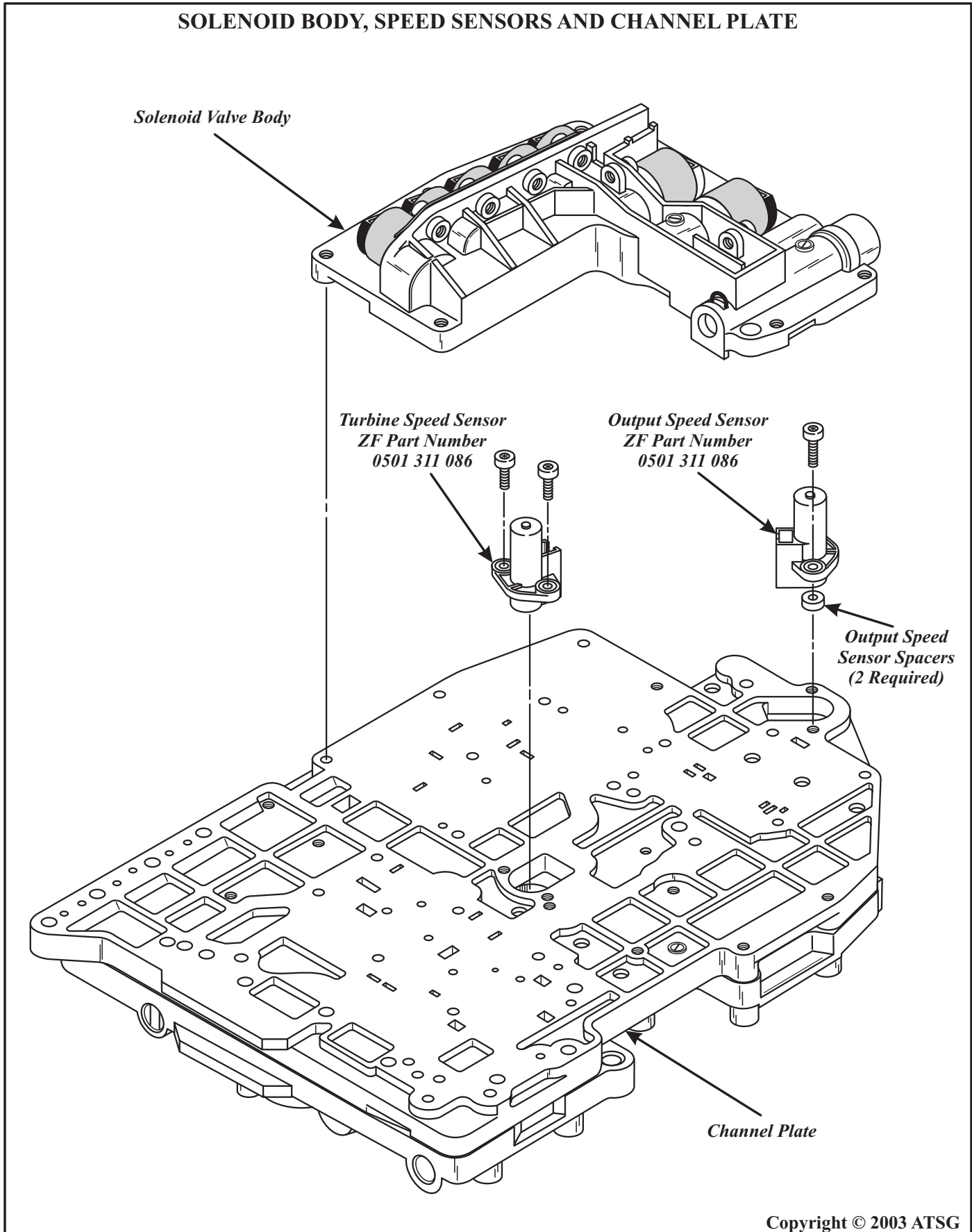

Copyright © 2003 ATSG

Figure 62

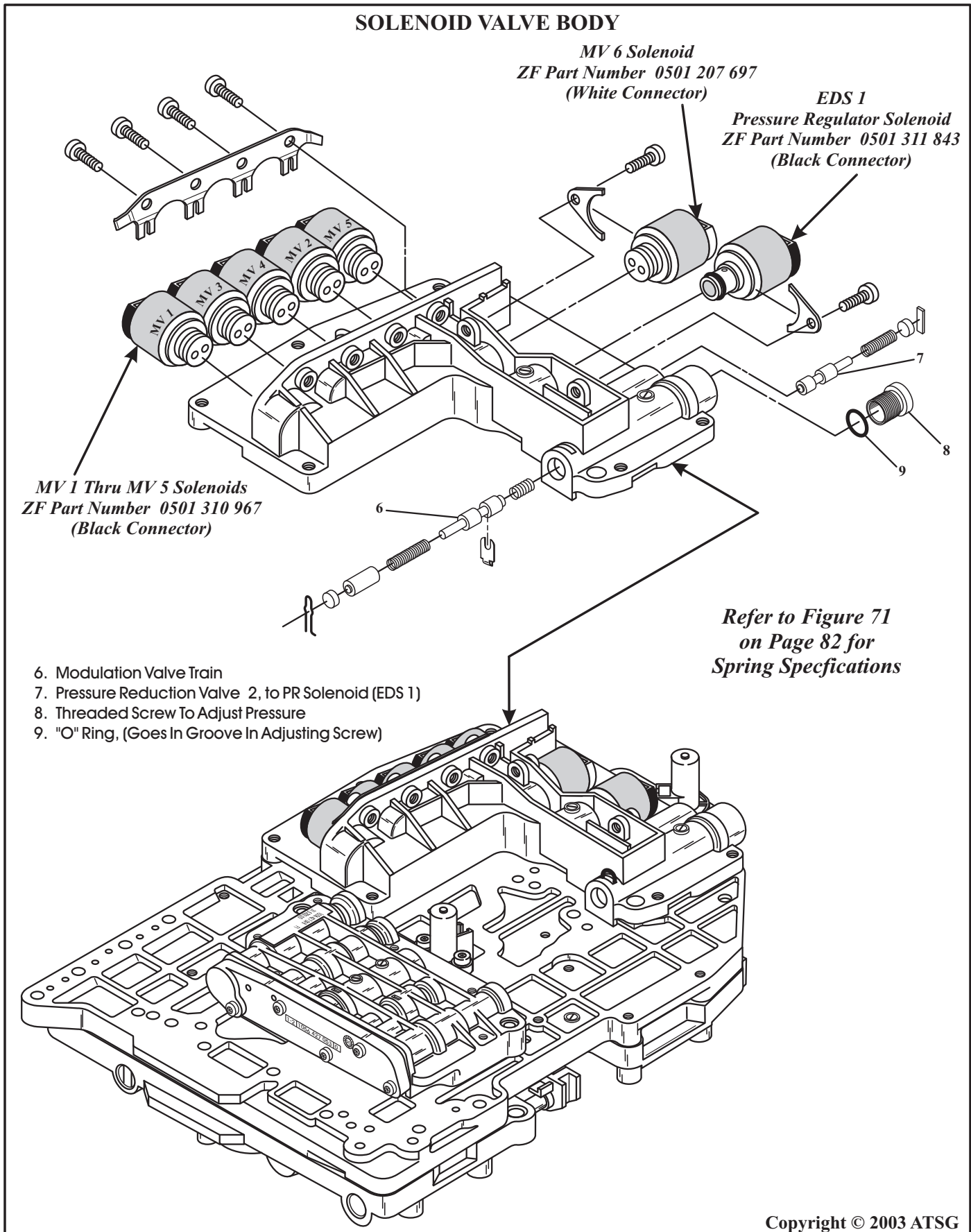

Copyright © 2003 ATSG

Figure 63

LOWER REAR VALVE BODY

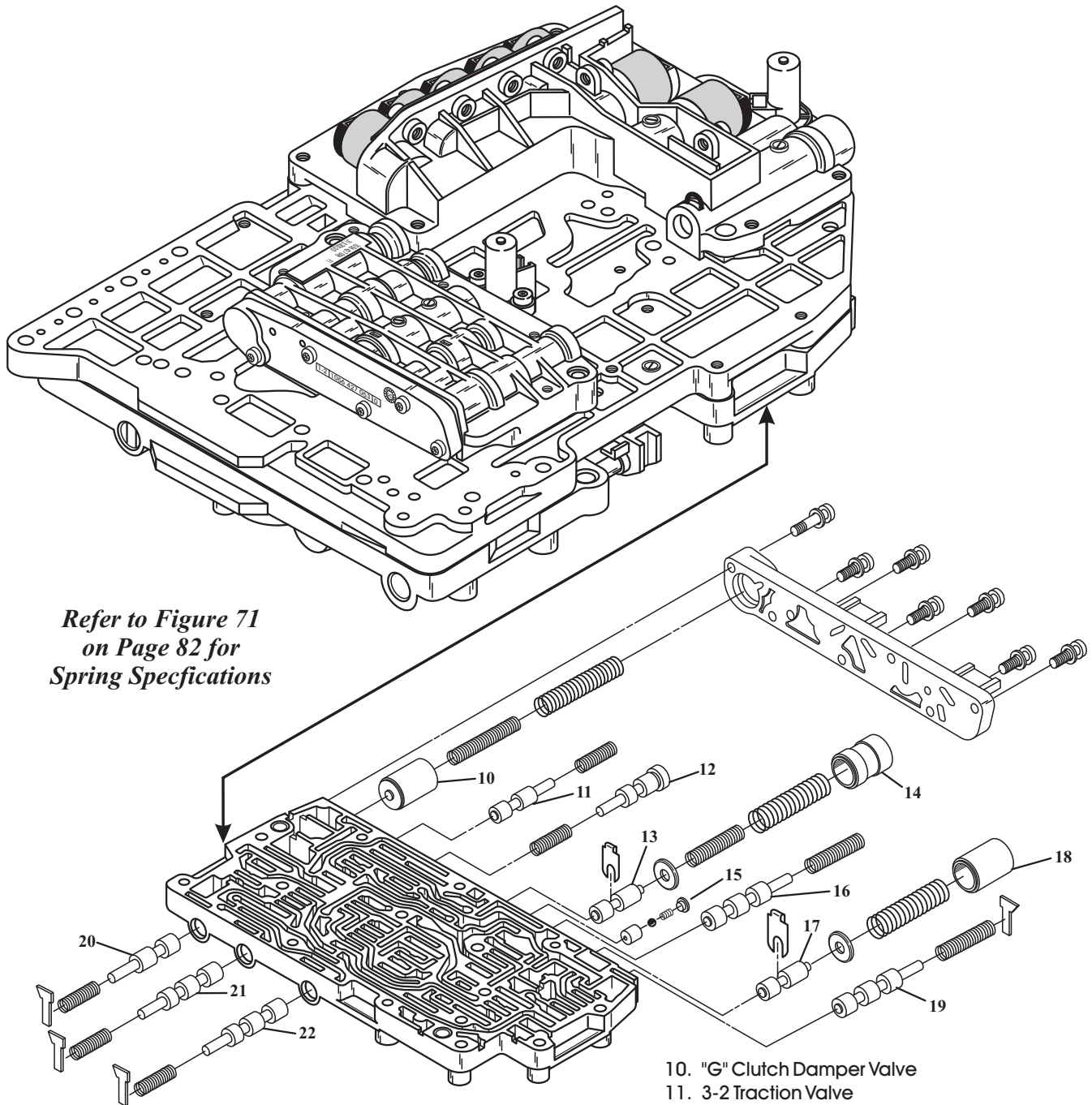

- 10. "G" Clutch Damper Valve
- 11. 3-2 Traction Valve
- 12. 2-3 Traction Valve
- 13. "D" Clutch Accumulator Regulator Valve
- 14. "D" Clutch Damper Valve
- 15. "D" Clutch One-Way Check Valve Assembly
- 16. Reverse Lock-Out Valve
- 17. "F" Clutch Accumulator Regulator Valve
- 18. "F" Clutch Damper Valve
- 19. Shift Valve Number 2
- 20. Pressure Reduction Valve For MV 1 thru MV 6
- 21. Traction Coast Valve Number 2
- 22. Traction Coast Valve Number 1

Copyright © 2003 ATSG

Figure 64

LOWER FRONT VALVE BODY

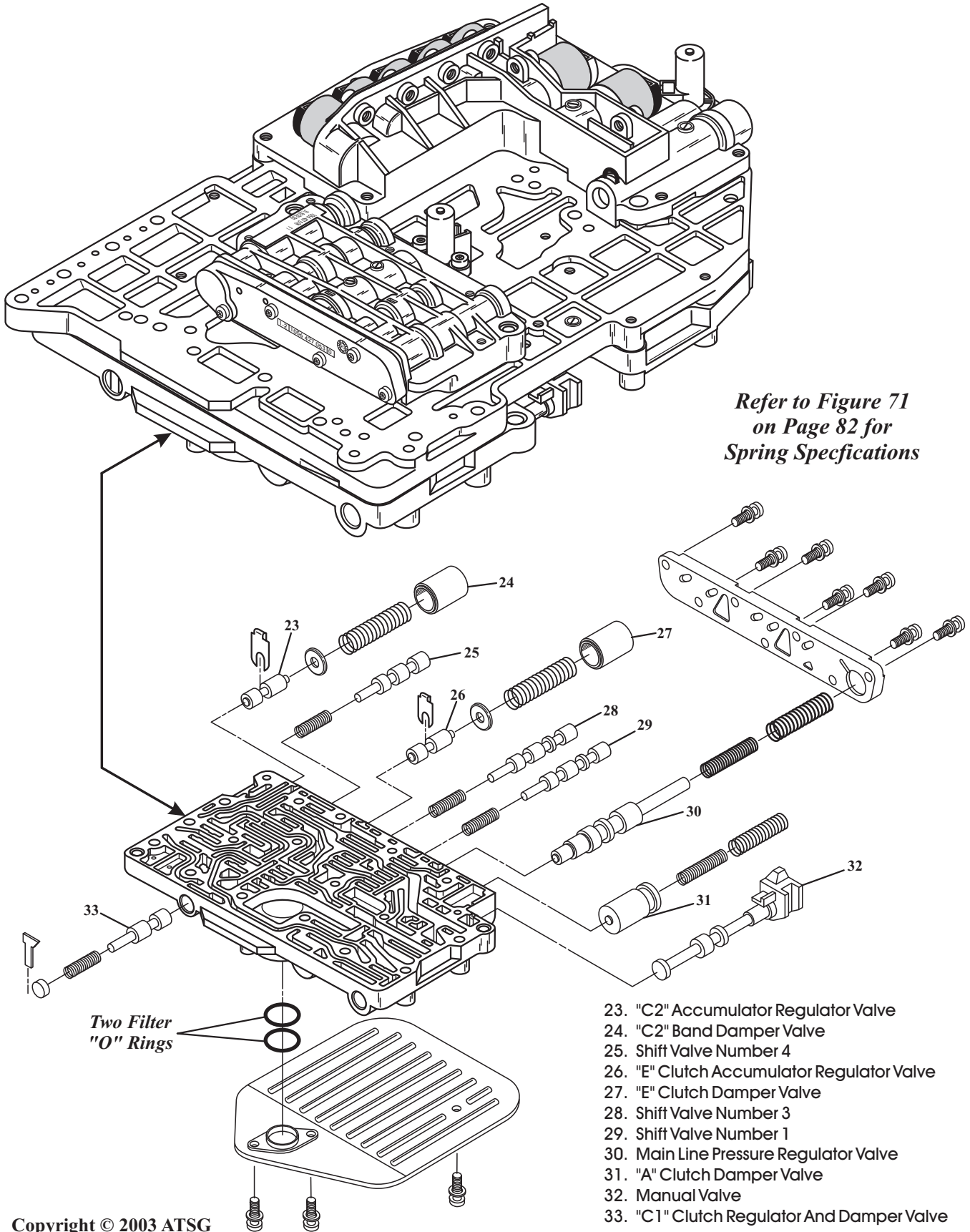

Copyright © 2003 ATSG

Figure 65

ZF 5HP-18
UPPER FRONT VALVE BODY CLIP LOCATIONS

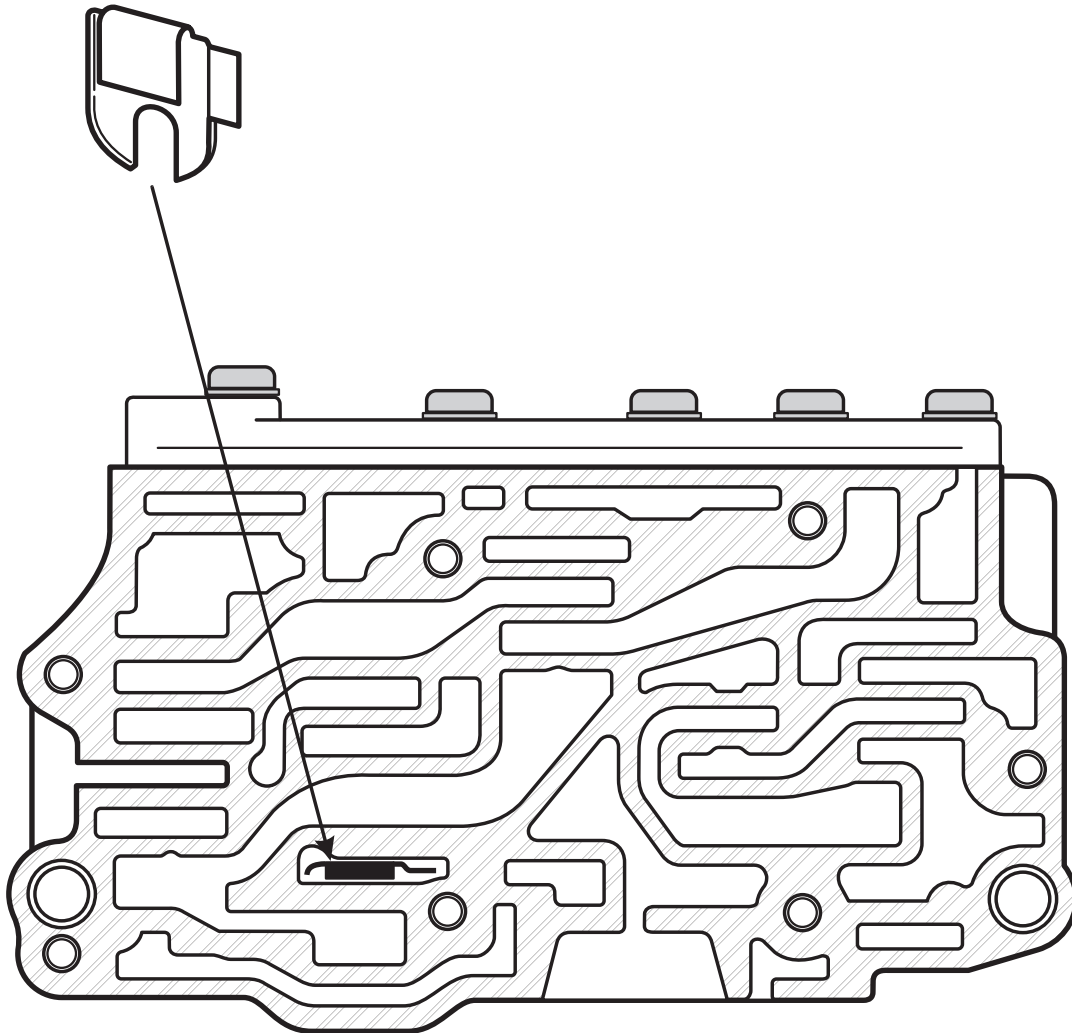

Copyright © 2003 ATSG

Figure 66

**ZF 5HP-18
LOWER FRONT VALVE BODY CLIP LOCATIONS**

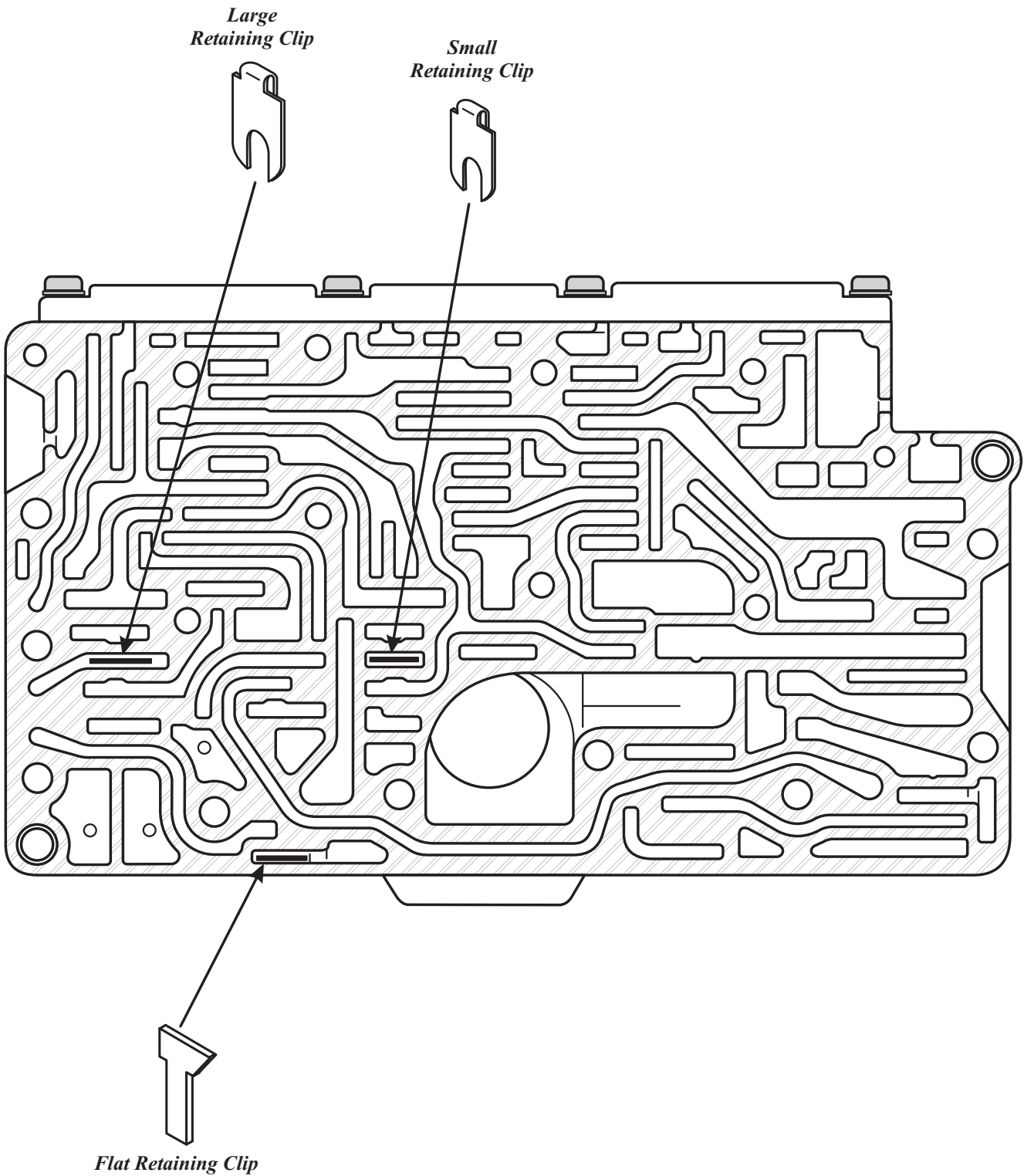

Copyright © 2003 ATSG

Figure 67

ZF 5HP-18
LOWER REAR VALVE BODY CLIP LOCATIONS

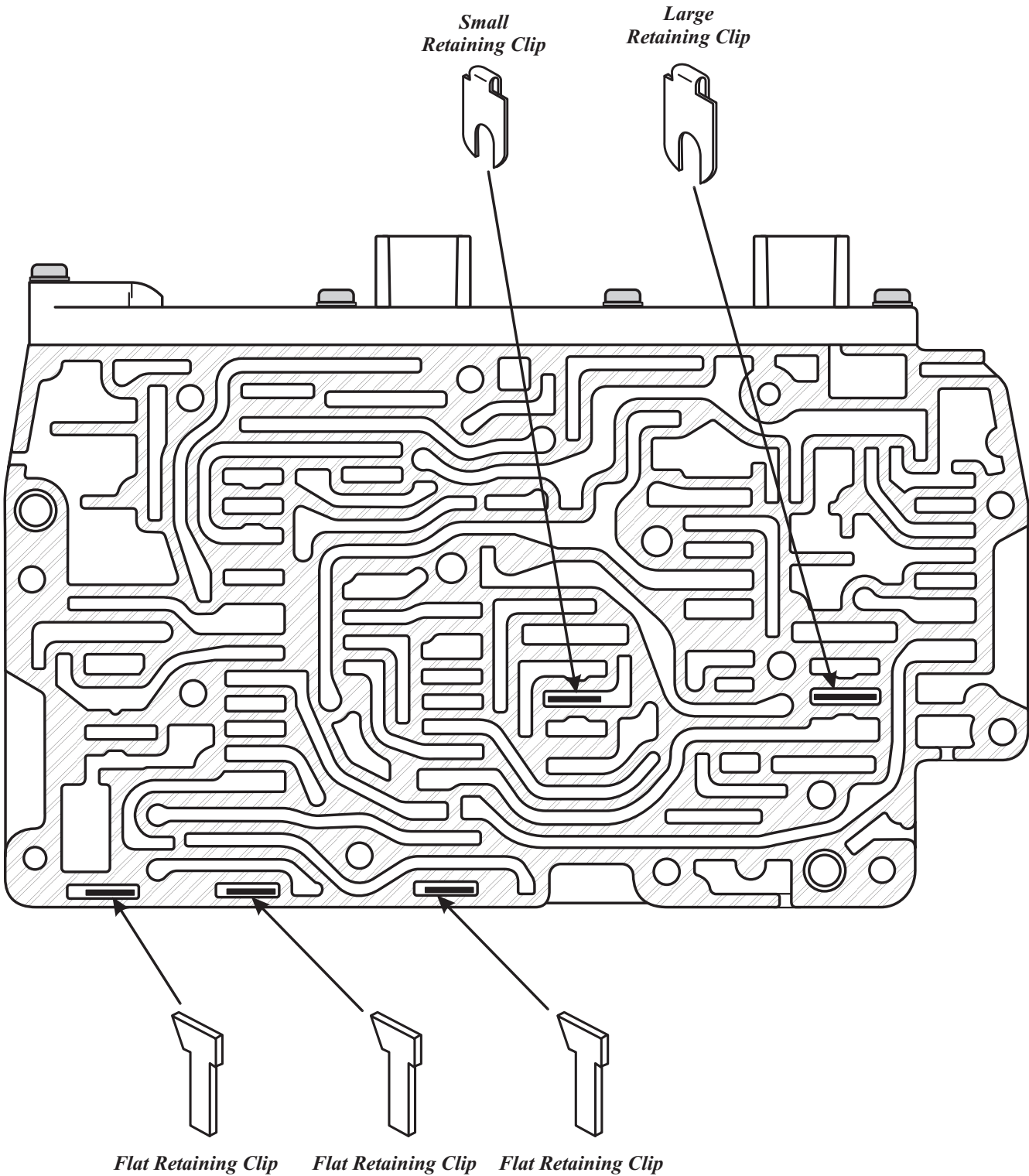

Copyright © 2003 ATSG

Figure 68

**ZF 5HP-18
SOLENOID VALVE BODY CLIP LOCATIONS**

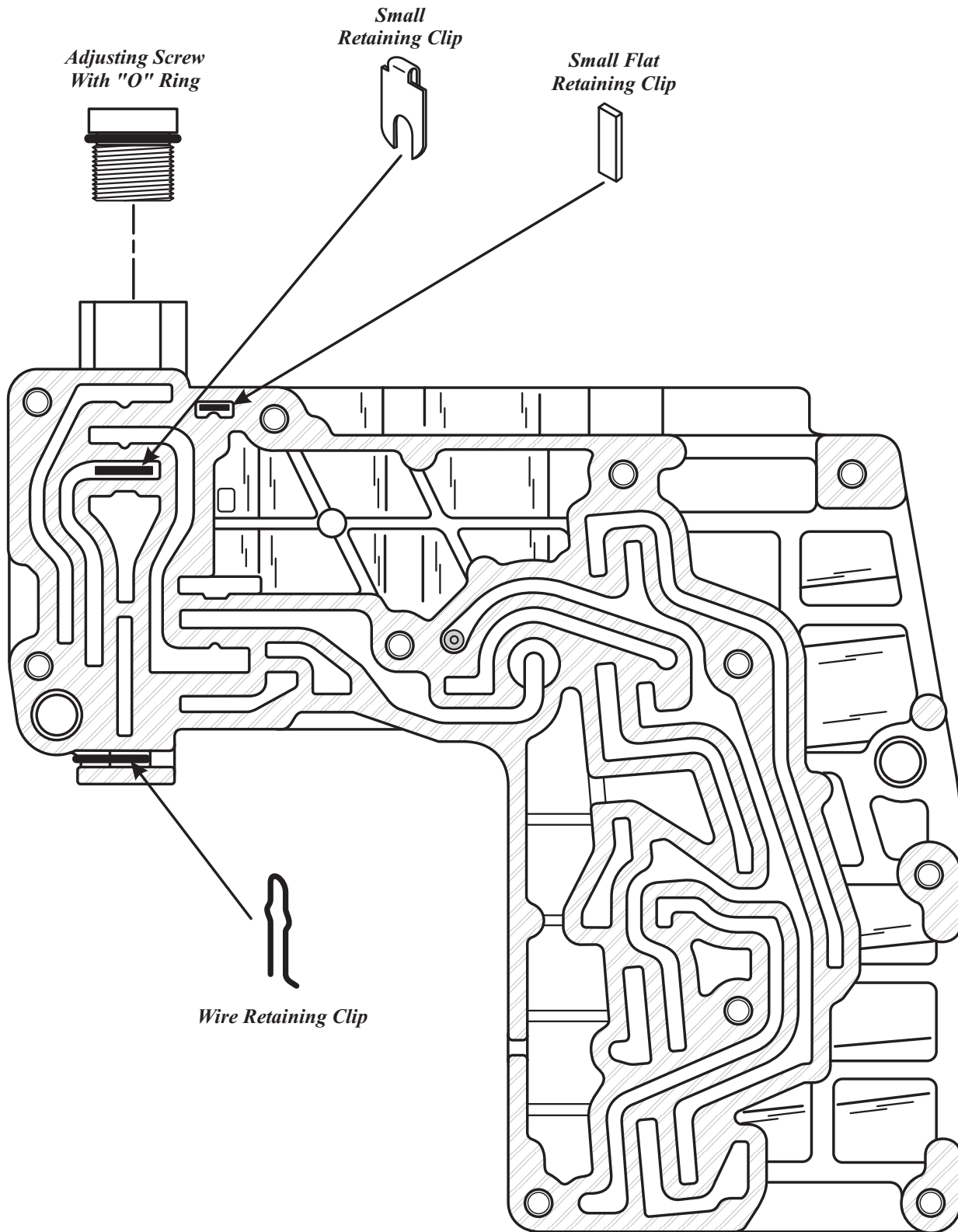

Figure 69

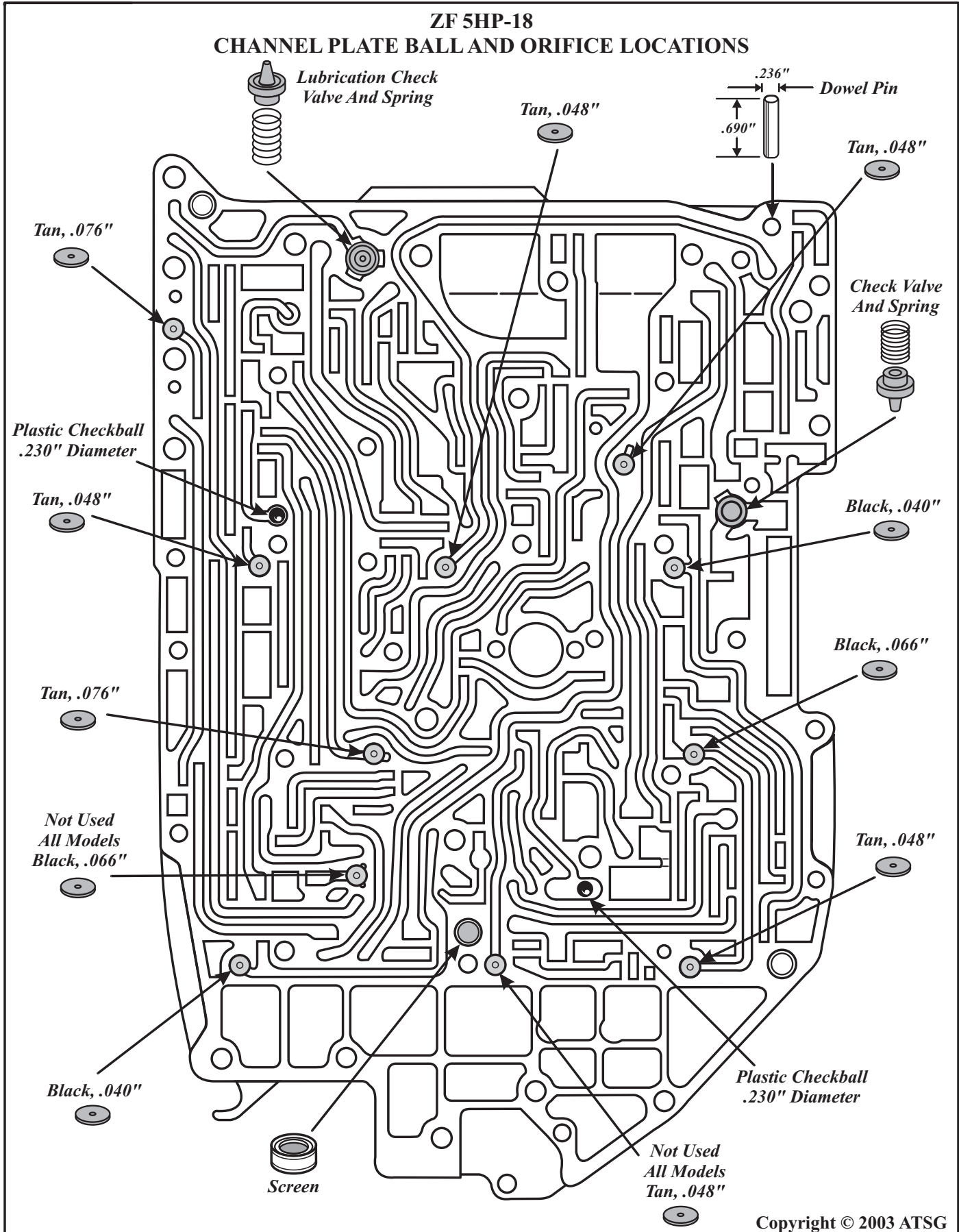

Figure 70

ZF 5HP-18FL SPRING SPECIFICATIONS

UPPER FRONT VALVE BODY

(1) TORQUE CONVERTER VALVE
 FREE LENGTH = 1.710"
 SPRING DIAMETER = .430"
 WIRE DIAMETER = .030"

(2) LUBRICATION VALVE
 FREE LENGTH = 1.774"
 SPRING DIAMETER = .445"
 WIRE DIAMETER = .043"

(3) LOCK-UP CONTROL VALVE
 FREE LENGTH = 1.550"
 SPRING DIAMETER = .430"
 WIRE DIAMETER = .038"

(4) 5-4 TRACTION VALVE
 FREE LENGTH = 1.900"
 SPRING DIAMETER = .360"
 WIRE DIAMETER = .030"

(5) 4-5 TRACTION VALVE
 FREE LENGTH = 1.630"
 SPRING DIAMETER = .360"
 WIRE DIAMETER = .030"

SOLENOID VALVE BODY

(6) MODULATION VALVE
 FREE LENGTH = 1.400"
 SPRING DIAMETER = .305"
 WIRE DIAMETER = .038"

(6) MOD. VALVE (ADJUST SIDE)
 FREE LENGTH = .780"
 SPRING DIAMETER = .305"
 WIRE DIAMETER = .026"

(7) PRES REDUCING VALVE 2
 FREE LENGTH = 1.560"
 SPRING DIAMETER = .350"
 WIRE DIAMETER = .043"

LOWER REAR VALVE BODY

(10) "G" DAMPER PIST (INNER)
 FREE LENGTH = 3.900"
 SPRING DIAMETER = .368"
 WIRE DIAMETER = .028"

(10) "G" DAMPER PIST (OUTER)
 FREE LENGTH = 4.120"
 SPRING DIAMETER = .590"
 WIRE DIAMETER = .042"

(11) 3-2 TRACTION VALVE
 FREE LENGTH = 1.625"
 SPRING DIAMETER = .373"
 WIRE DIAMETER = .035"

(12) 2-3 TRACTION VALVE
 FREE LENGTH = 1.770"
 SPRING DIAMETER = .356"
 WIRE DIAMETER = .023"

(14) "D" DAMPER PIST (INNER)
 FREE LENGTH = 1.565"
 SPRING DIAMETER = .430"
 WIRE DIAMETER = .039"

(14) "D" DAMPER PIST (OUTER)
 FREE LENGTH = 2.925"
 SPRING DIAMETER = .592"
 WIRE DIAMETER = .043"

(16) REVERSE LOCKOUT VALVE
 FREE LENGTH = 1.820"
 SPRING DIAMETER = .440"
 WIRE DIAMETER = .039"

(18) "F" DAMPER PISTON
 FREE LENGTH = 3.475"
 SPRING DIAMETER = .568"
 WIRE DIAMETER = .039"

(19) SHIFT VALVE 2
 FREE LENGTH = 1.780"
 SPRING DIAMETER = .365"
 WIRE DIAMETER = .030"

(20) PRES REDUCING VALVE 1
 FREE LENGTH = 1.470"
 SPRING DIAMETER = .378"
 WIRE DIAMETER = .043"

(21) TRACTION VALVE 2
 FREE LENGTH = 1.780"
 SPRING DIAMETER = .360"
 WIRE DIAMETER = .031"

(22) TRACTION VALVE 1
 FREE LENGTH = 1.780"
 SPRING DIAMETER = .360"
 WIRE DIAMETER = .031"

Note: The number in front of the name of the valve line-up is the illustration number in the ATSG illustrations in this manual.

Note: There is now available from ZF distributors a "Valve Body Kit" for the 5HP-18 that includes all new stock springs, all check balls, all orifices and screens. ZF part number "5HP-18 VBK".

LOWER FRONT VALVE BODY

(24) "C2" DAMPER PISTON
 FREE LENGTH = 3.425"
 SPRING DIAMETER = .585"
 WIRE DIAMETER = .031"

(25) SHIFT VALVE 4
 FREE LENGTH = 1.780"
 SPRING DIAMETER = .366"
 WIRE DIAMETER = .031"

(27) "E" DAMPER PISTON
 FREE LENGTH = 3.500"
 SPRING DIAMETER = .554"
 WIRE DIAMETER = .040"

(28) SHIFT VALVE 3
 FREE LENGTH = 1.776"
 SPRING DIAMETER = .365"
 WIRE DIAMETER = .031"

(29) SHIFT VALVE 1
 FREE LENGTH = 1.766"
 SPRING DIAMETER = .365"
 WIRE DIAMETER = .031"

(30) PRESSURE REG (INNER)
 FREE LENGTH = 3.150"
 SPRING DIAMETER = .448"
 WIRE DIAMETER = .048"

(30) PRESSURE REG (OUTER)
 FREE LENGTH = 2.930"
 SPRING DIAMETER = .600"
 WIRE DIAMETER = .048"

(31) "A" DAMPER PIST (INNER)
 FREE LENGTH = 2.880"
 SPRING DIAMETER = .442"
 WIRE DIAMETER = .048"

(31) "A" DAMPER PIST (OUTER)
 FREE LENGTH = 3.078"
 SPRING DIAMETER = .577"
 WIRE DIAMETER = .042"

(33) "C1" REGULATOR VALVE
 FREE LENGTH = 1.975"
 SPRING DIAMETER = .380"
 WIRE DIAMETER = .035"

Figure 71

ZF-5HP-18
NO MOVE OR DELAYED ENGAGEMENT

COMPLAINT: Vehicles equipped with ZF5HP18 may exhibit a No movement or a delayed engagement condition, before or after overhaul.

CAUSE: The cause may be, that the "Bypass Ball," located in the pump as shown in Figure 72, may have shrunken down and traveled back through the pump passage leading to the Torque Converter Valve, sticking the valve in the "stroked" position (See Figure 73). When this valve is stuck in this position it may cause the Torque Converter to drain-back after sitting for a prolonged period of time. When the vehicle is started after sitting, it may take 10 to 15 minutes for the Torque Converter to fill back up, and this all depends on the positioning of the stuck Torque Converter Valve.

CORRECTION: Locate the Torque Converter Valve, as shown in Figure 74, and free the valve up, removing the shrunken Bypass Ball from binding the valves movement. Replace the assembly in pump body with a new one from ZF, available under ZF part number 1056-210-143, *if the capsule can be removed* from the pump body.

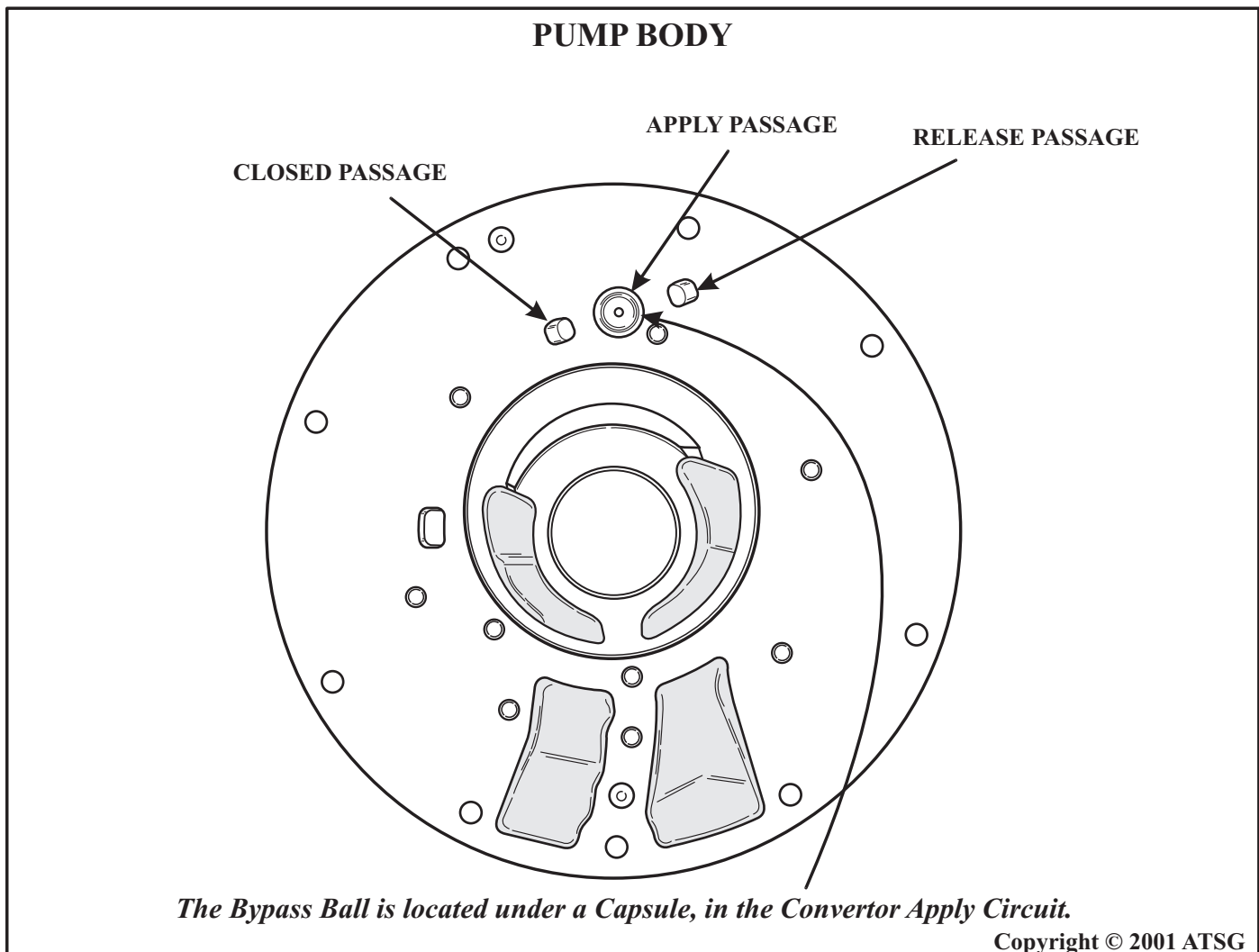
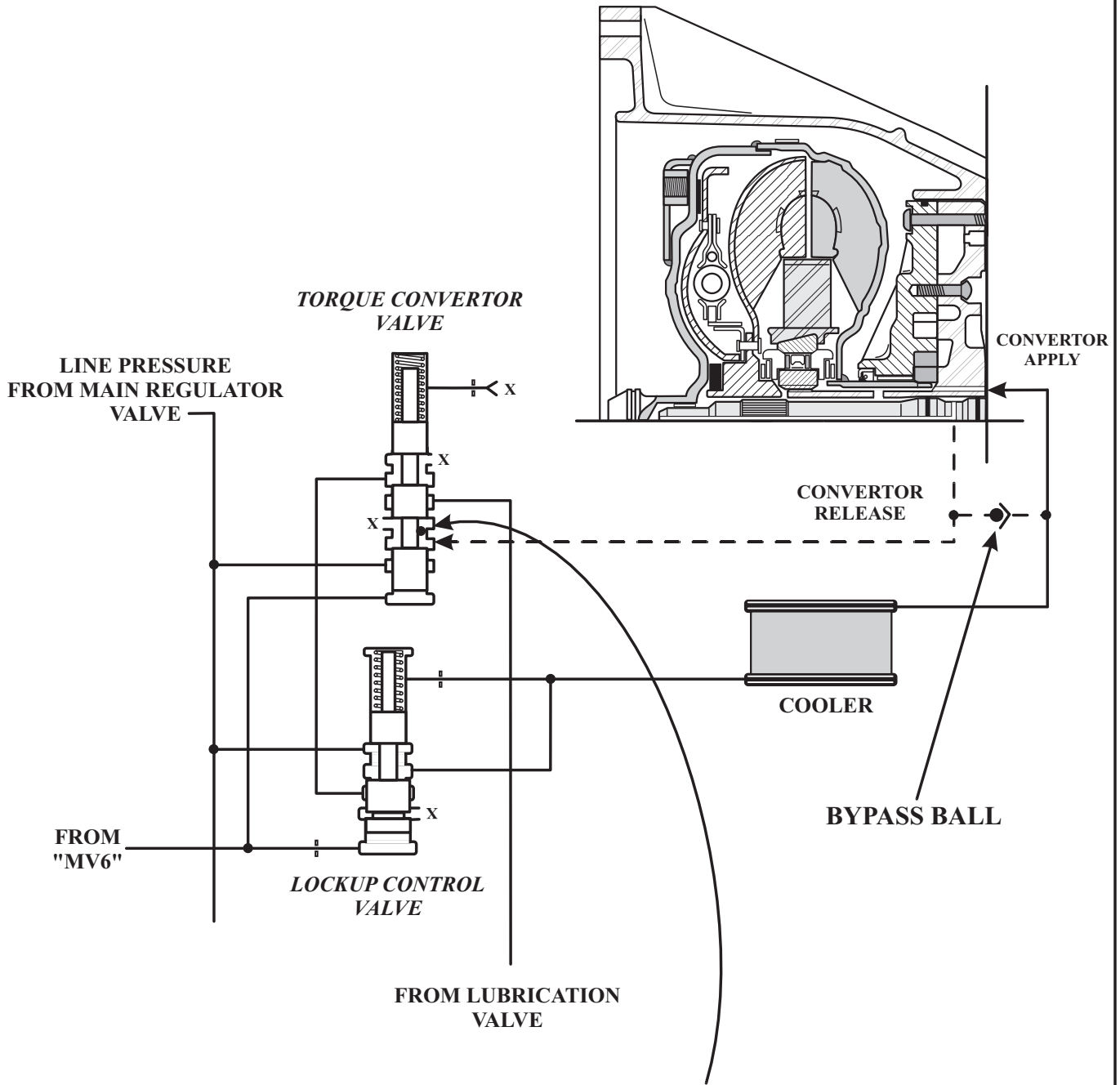

Figure 72

LOCKUP HYDRAULIC CIRCUIT



The "Bypass Ball" shrinks and travels back through to the Torque Converter Valve and lodges itself in this passage, sticking the valve in this approximate position.

Figure 73

ZF-5HP-18 UPPER FRONT VALVE BODY

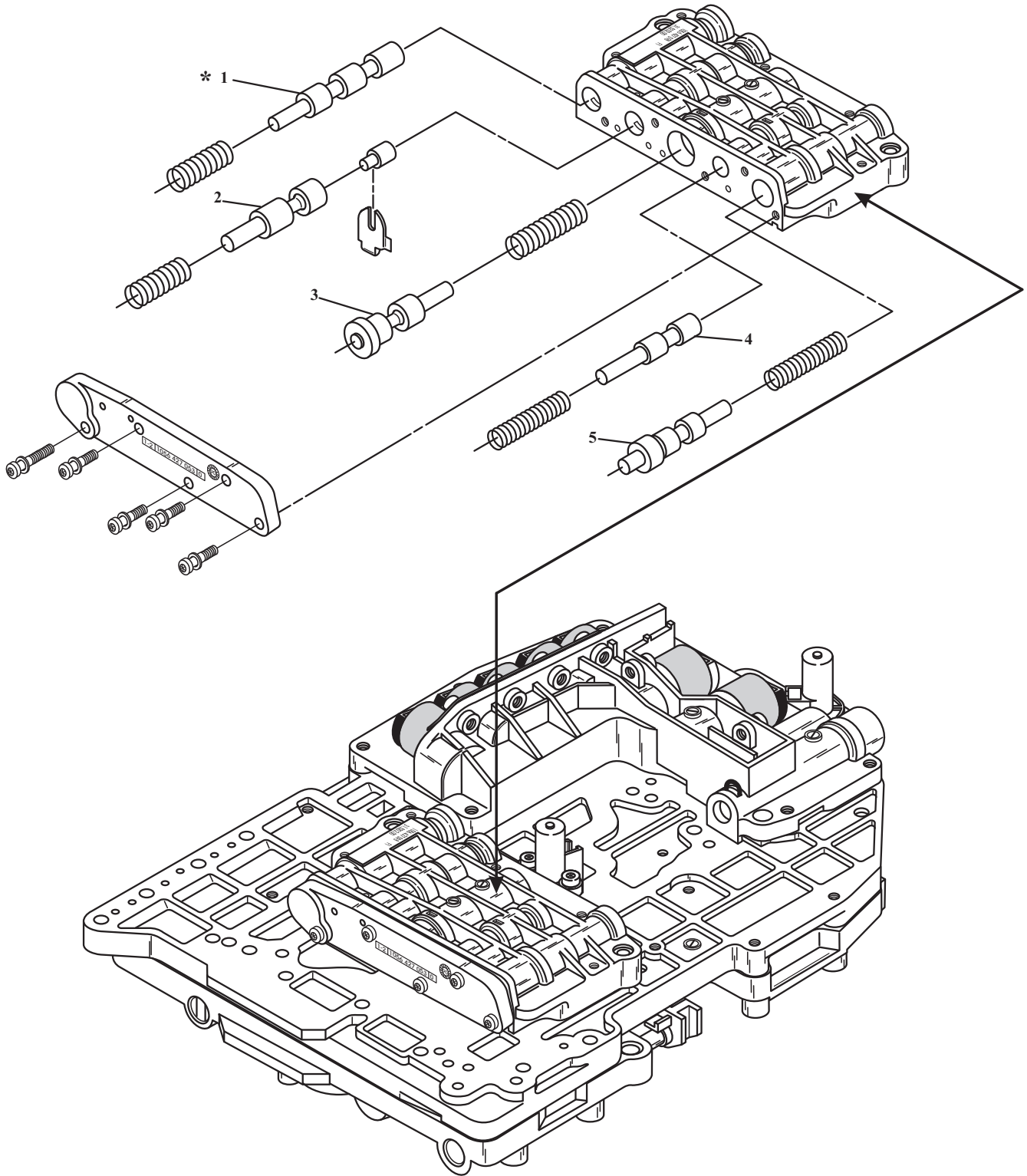

- *1. Torque Converter Valve
- 2. Lubrication Valve Train
- 3. Lock-Up Control Valve
- 4. 5-4 Traction Valve

Copyright © 2001 ATSG

Figure 74

**ZF-5HP-18
"BIND-UP" WITH SELECTOR IN
MANUAL "2" POSITION, 1st GEAR**

COMPLAINT: Before or after overhaul, vehicles equipped with ZF-5HP-18, may exhibit a "Bind-Up" condition in the Manual "2" position, 1st gear.

CAUSE: The cause may be, the plastic "D" Clutch One-way Check Valve assembly located in the Lower Rear valve body, shown in Figure 76, may be broken allowing the "B" Clutch (Reverse Input Clutch) to be on while the "D" Clutch (Low/Reverse Clutch) is on in 1st gear.

CORRECTION: Replace the "D" Clutch One-way Check Valve assembly , as shown in Figure 75, with a new assembly, part number 1043 226 028 from ZF, or a new "Aluminum" check valve assembly offered by Mario Aristides. Phone (305) 666-3544 or Fax (305) 666-8238.

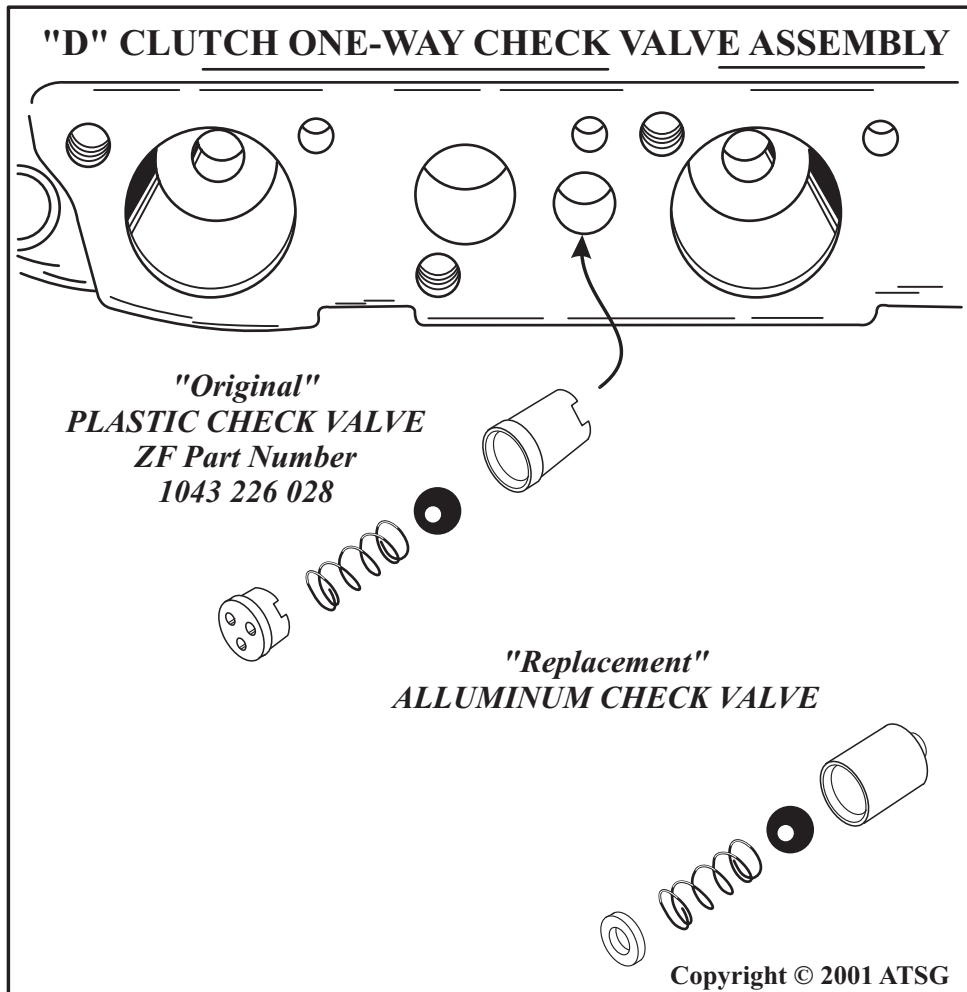
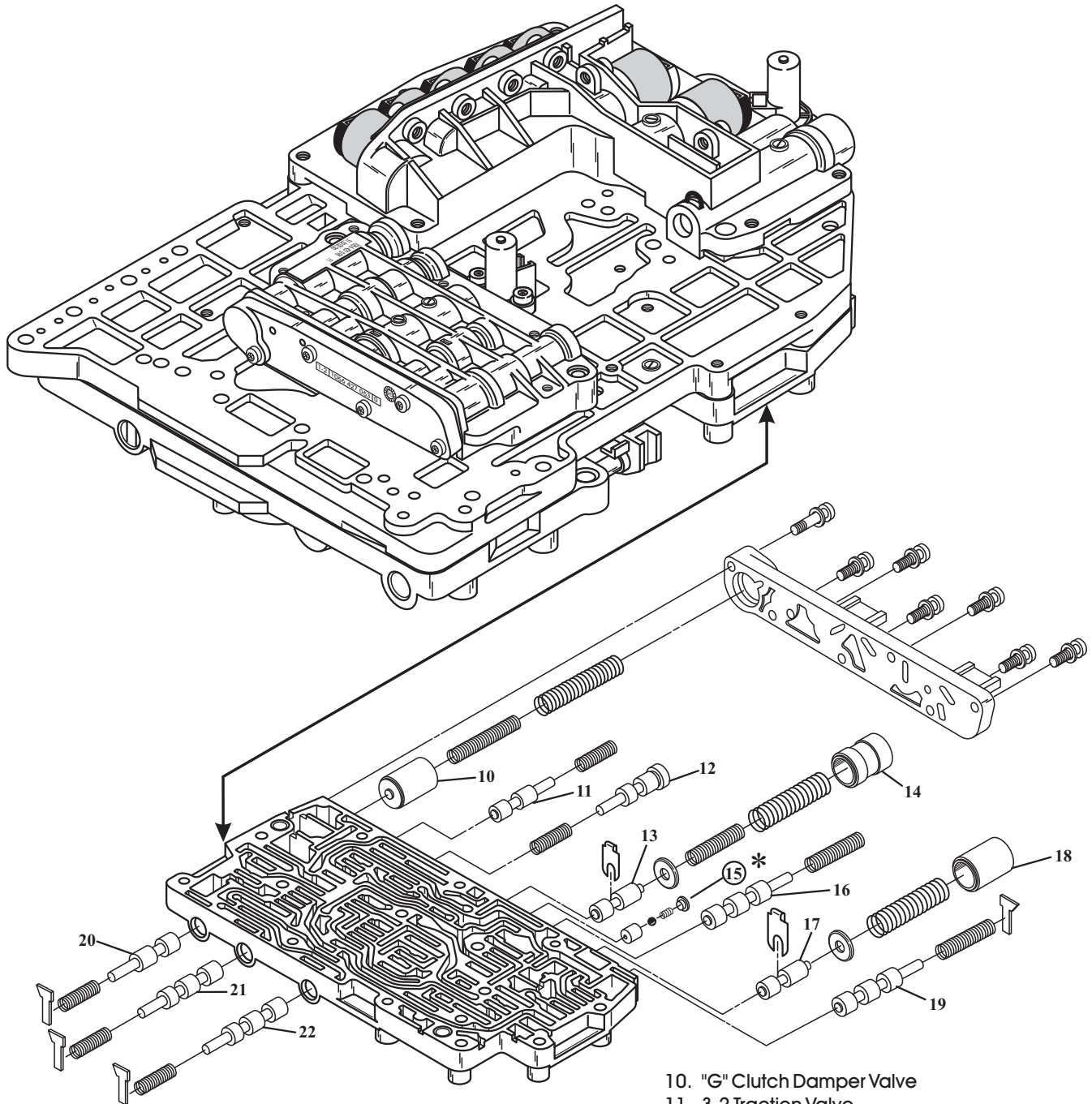

Figure 75

LOWER REAR VALVE BODY



- 10. "G" Clutch Damper Valve
- 11. 3-2 Traction Valve
- 12. 2-3 Traction Valve
- 13. "D" Clutch Accumulator Regulator Valve
- 14. "D" Clutch Damper Valve
- * 15. "D" Clutch One-Way Check Valve Assembly
- 16. Reverse Lock-Out Valve
- 17. "F" Clutch Accumulator Regulator Valve
- 18. "F" Clutch Damper Valve
- 19. Shift Valve Number 2
- 20. Pressure Reduction Valve For MV 1 thru MV 6
- 21. Traction Coast Valve Number 2
- 22. Traction Coast Valve Number 1

Copyright © 2001 ATSG

Figure 76

We wish to thank the following for supplying the actual valve bodies that have made these illustrations possible.



LORY
TRANSMISSION
PARTS

2414 SW 8TH STREET
MIAMI, FLORIDA 33135
TOLL FREE (800) 966-4621
PHONE (305) 642-4621
FAX (305) 541-1444

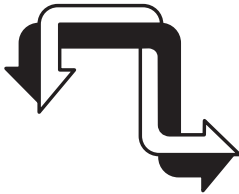

ERIKSSON INDUSTRIES
DIVISION OF
WENTWORTH ENGINEERING, INC.
146 B ELM STREET
OLD SAYBROOK, CT 06475
TOLL FREE (800) 388-4418

INDEPENDENT TRANSMISSION SERVICE
AND MARIO ARISTIDES

5846 SW 68TH STREET
SOUTH MIAMI, FLORIDA 33143
PHONE (305) 666-3544
PHONE (305) 666-4208
FAX (305) 666-8238

BMW ZF-5HP-19FL
DIAGNOSTIC INFORMATION

FOUND IN:

BMW 97-Current, 3 Series E46, 5 Series E39, 7 Series E38.
Audi 95-Current, A4, A8,
Audi 97-Current, A6,
Porsche Boxter 1996-1997
VW Passat 96-Current

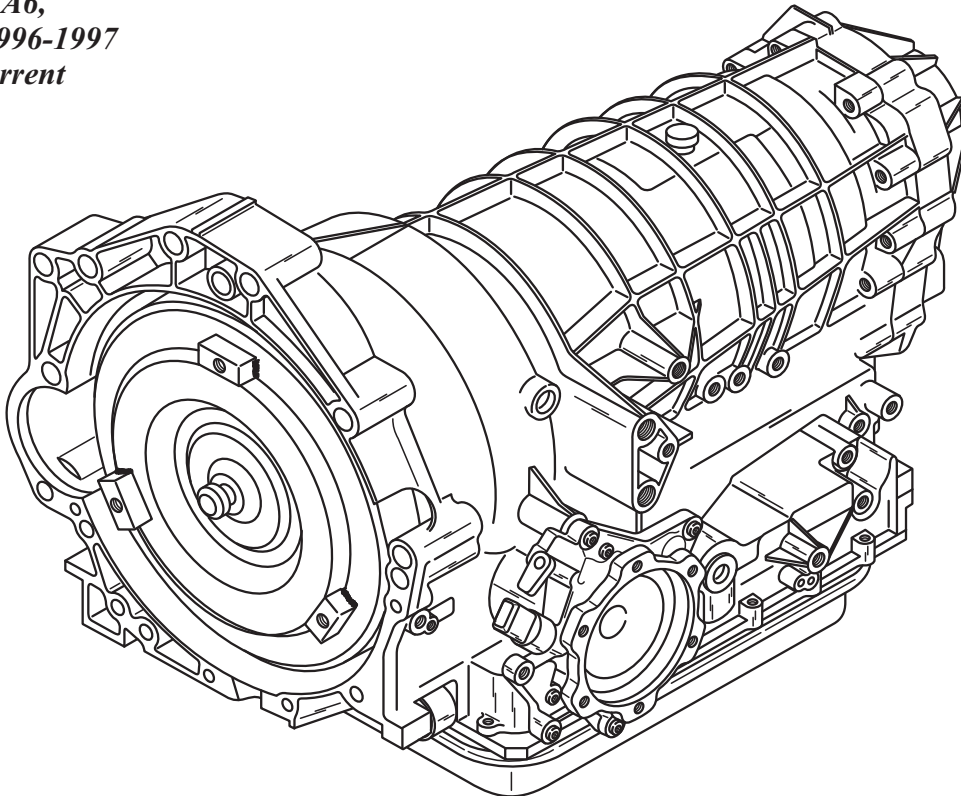

This transmission is manufactured in Germany by ZF and carries the designation ZF-5HP-19..
The ZF-5HP-19 Series is an electronically controlled, five speed automatic transmission with a lock-up clutch type torque converter. Two planetary gear sets, one Ravigneaux gear set and one standard planetary gear set on the output side, four rotating multiple disc clutches, three multiple disc brake clutches, and one sprag clutch (Freewheel) are used to provide the five forward speeds and reverse.

Figure 77



TECHNICIANS DIAGNOSTIC GUIDE

BMW, AUDI, PORSCHE

Refer to Figure 78 for Clutch and Band Application Chart.

Refer to Figure 79 and 80 for Manual Shift Lever Operation, and Failsafe Operation.

Refer to Figures 81, 82, and 83 for Solenoid identification and both MV Solenoid Operation and EDS Solenoid Operation and Tests.

Refer to Figure 84 for wiring harness identification, internal wiring schematic, and transmission case connector pin identification and functions.

Refer to Figure 85 for Shift Solenoid Application chart. Notice that EDS 1 Solenoid is used for line pressure control, and EDS 4 is used for converter clutch.

Refer to Figure 86 for internal components resistance chart, with the pins identified for both the transmission case connector and the Electronic Control Unit.

Refer to Figure 87 for Upper Front Valve Body exploded view and identification of valves.

Refer to Figure 88 for Upper Rear Valve Body exploded view and identification of valves.

Refer to Figure 89 for Lower Front Valve Body exploded view and identification of valves.

Refer to Figure 90 for Lower Rear Valve Body exploded view and identification of valves.

Refer to Figure 91 for Channel Plate exploded view and turbine speed sensor location on the channel plate.

Refer to Figures 92, 93, and 94 for valve body retainer locations in the various valve bodies.

Refer to Figure 95 for the locations of the orifices, checkballs, screens, and the check valves and springs that are located in the channel plate.

Refer to Figure 96 for all valve body spring specifications, as observed in a used valve body.

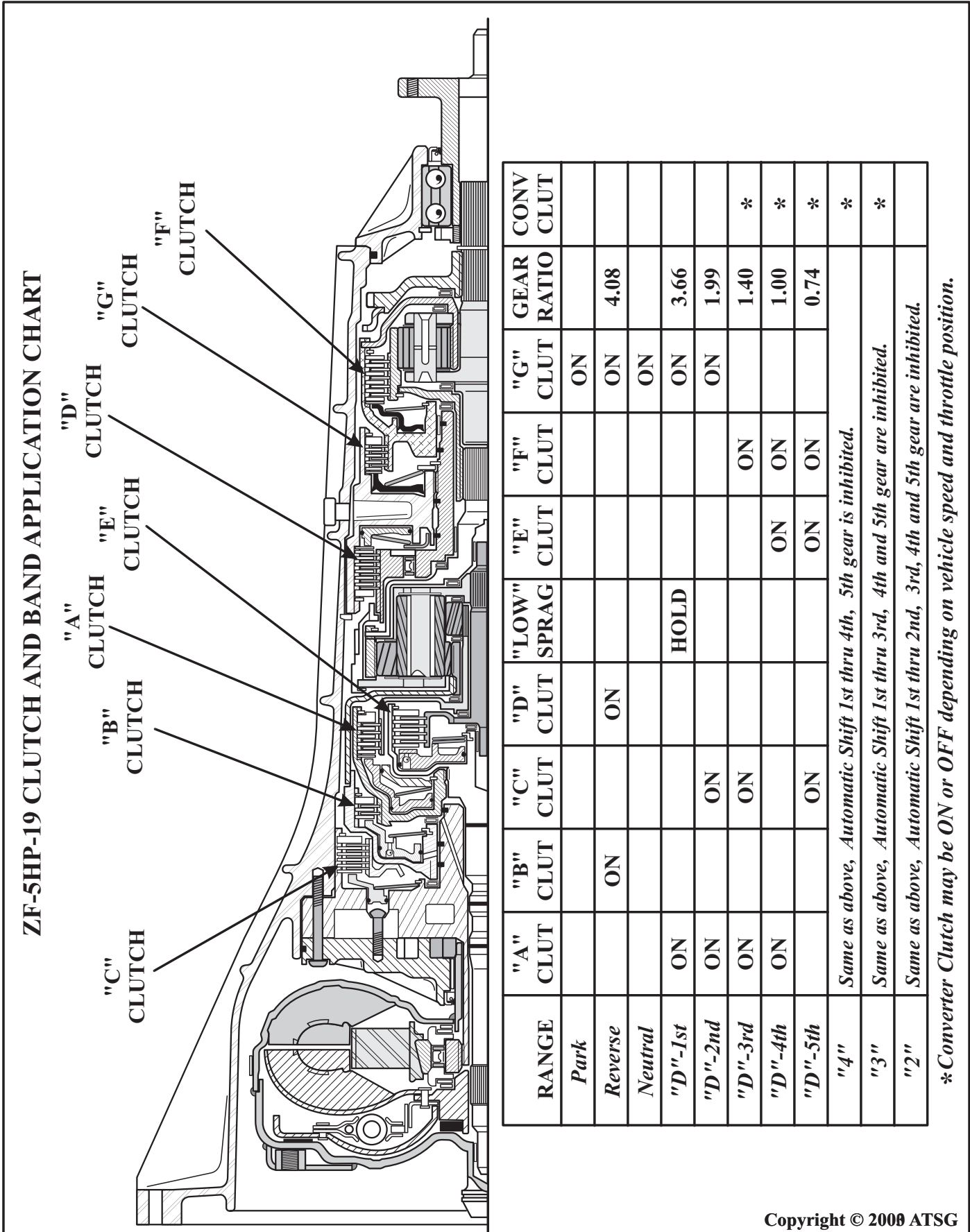

Copyright © 2008 ATSG

Figure 78

SHIFT QUADRANT

- P** = Parking Pawl Engaged
- R** = Reverse Gear
- N** = Neutral
- D** = Automatic Shifts 1st thru 5th Gears
- 4** = Automatic Shifts 1st thru 4th Gears.
5th Gear is locked out.
- 3** = Automatic Shifts 1st thru 3rd Gears.
4th and 5th Gear is locked out.
- 2** = Automatic Shifts 1st thru 2nd Gears.
3rd, 4th and 5th Gear is locked out.

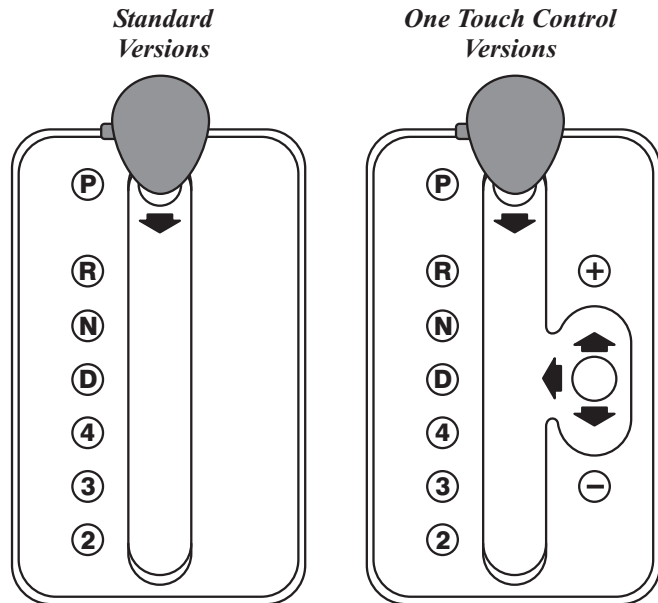

Note: 1st gear, which has an engine braking effect, is selected electronically, dependent on being in Manual Position 2 and at a suitable road speed.

ONE-TOUCH CONTROL VERSIONS

Standard versions have a shift quadrant using only the left gate as shown above. The versions that are equipped with One-Touch Control, supplied as an option and model dependent, have a two section shift quadrant, also shown above. Positions P, R, N, D, 4, 3, 2, can be selected in the left-hand gate and all shifts are automatic depending on which selection was made. When the selector lever is placed in the right-hand gate, the transmission can be up-shifted manually, by tapping the lever in the direction of the "Plus" symbol, or down-shifted manually by tapping the lever in the direction of the "Minus" symbol. The separate program switch is no longer needed, as functions A and B have replaced it.

"A" Left-Hand Gate = DSP (Dynamic Shift Program)

With the selector lever in the left-hand gate, the Dynamic Shift Program (DSP) looks at the speed of accelerator pedal movement, engine speed, vehicle acceleration via output speed and other important parameters in the control unit.

The Electronic Control Unit (ECU) includes modules which will automatically modify the transmissions shift characteristics according to the driving style and the road conditions. These modules effectively replace the program switch.

If the engine temperature is below approximately 40°C (104°F) when it is started, the ECU control system enters a special warm-up program in order to shorten the catalytic converter's warming-up phase. This warm-up program is terminated after approximately 2 minutes of operation.

Continued on next Page

Figure 79

"A" Left-Hand Gate = DSP (Dynamic Shift Program) (Cont'd)

If the speed of the accelerator pedal movement is greatly varied, the shift points are modified for maximum fuel economy, or a more sporting driving style accordingly. There are three shift patterns for this purpose.

- 1. = Comfort Oriented, Economical Driving Style**
- 2. = Average Driving Style**
- 3. = Sports Oriented, High Performance Driving Style**

When the vehicle is started cold, it moves off in shift pattern number one, provided that the transmission temperature is above 40°C (104°F). This shift pattern places the emphasis on maximum fuel economy. If a more enthusiastic driving style is required, detected by the accelerator opening and closing more rapidly, the ECU switches between the shift patterns and adopting shift pattern three where necessary.

If a calmer driving style is resumed, the ECU returns to the lower shift pattern, and will once again place the emphasis on fuel consumption.

"B" Right-Hand Gate = Manual Shift Program

When the selector lever is moved to the right-hand gate, the current gear is retained, and the transmission can be shifted to a lower or higher gear using the one-touch function.

There are engine speed limits for each gear, as in the transmission can only be shifted down if the maximum engine speed will not be exceeded by doing so. No mandatory upshifts will take place.

If the One-Touch feature is not used when the selector lever is in the right-hand gate, for durability concerns, the transmission is allowed to down-shift automatically to 1st gear.

FAILSAFE OPERATION

When a system fault is detected which could impair normal reliable operation, the ECU module interrupts the power supply to Pin 12 at the transmission case connector. The ECU module also alerts the driver of any faults by signaling the vehicles "check control" system. To enable the vehicle to be driven to a repair shop, the following manual gear selections are permitted:

Selector Lever Position	P R N D 4 3 2
Actual Gear Obtained	P R N 4 4 4 4

ZF-5HP-19 SOLENOID IDENTIFICATION AND LOCATIONS

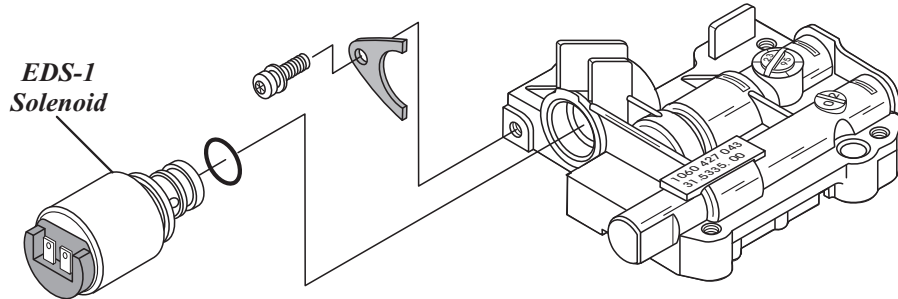

SPECIAL NOTE:

EDS-1 Solenoid
 .650" Snout Diameter
 Requires Green "O" Ring

EDS-2, 3, 4 Solenoids
 .670" Snout Diameter
 Requires Black "O" Ring

MV-1, 2, 3 Solenoids
 Use NO "O" Rings

<i>ZF Part Numbers</i>	
<i>EDS-1 Solenoid</i>	<i>0501 209 875</i>
<i>EDS-2, 3, 4, Solenoid</i>	<i>0501 208 562</i>
<i>MV-1, 2, 3, Solenoid</i>	<i>0501 313 506</i>

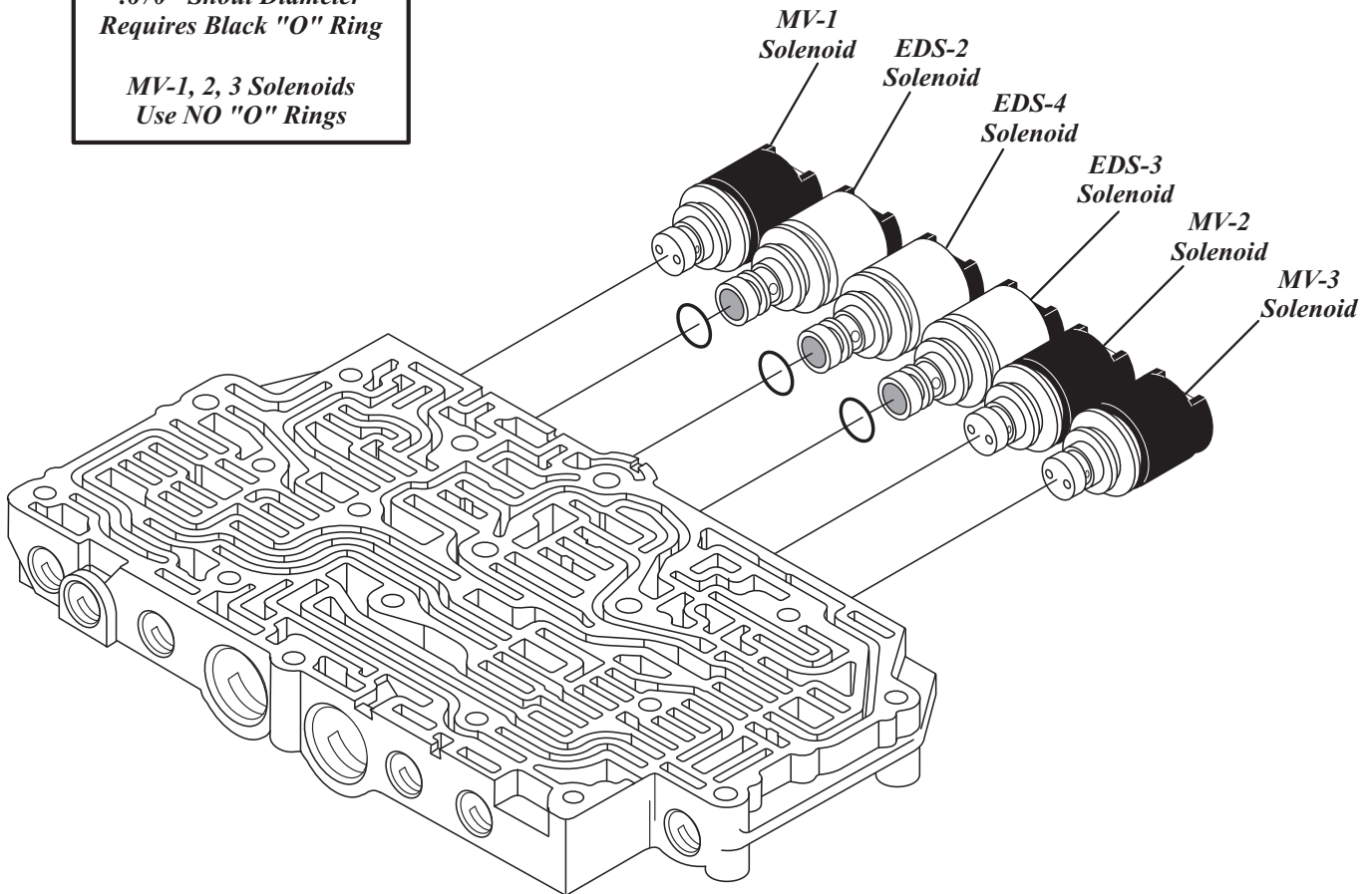
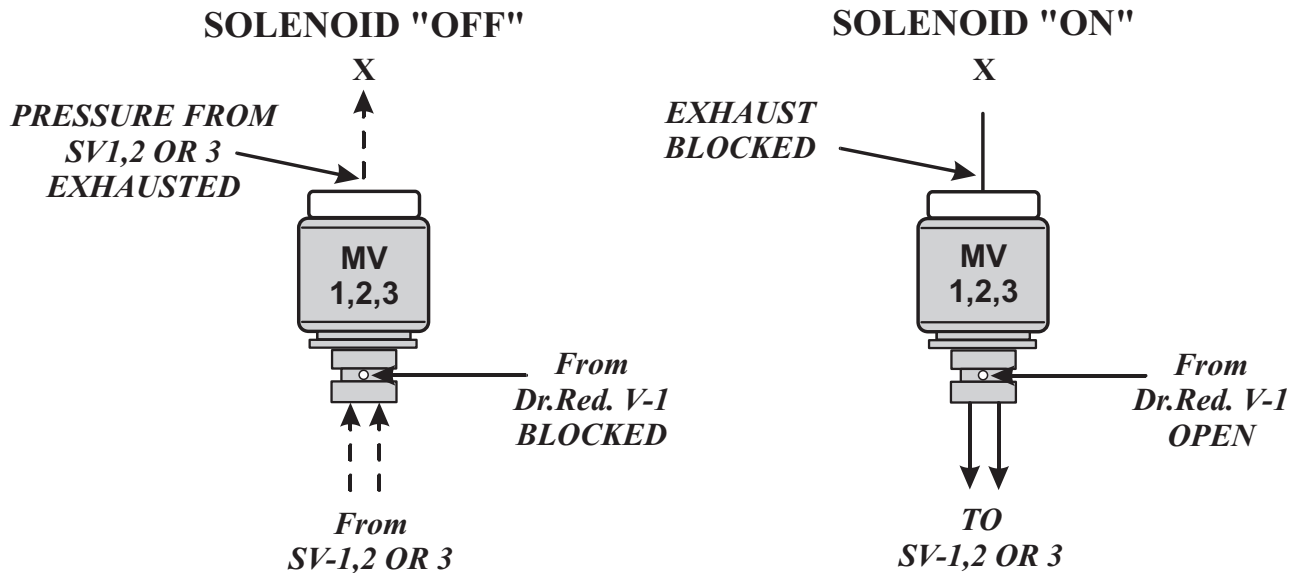

Figure 81

MV1, 2 AND 3 OPERATION



SUMMARY:

When MV 1, 2 or 3 is "OFF" Solenoid reducing pressure, from Dr.Red. V-1, is blocked by the solenoid and oil pressure from SV 1, 2 or 3 is exhausted at the rear of the solenoid.

When MV 1, 2 or 3 is "ON" Solenoid reducing pressure, From Dr.Red. V-1, is open through the solenoid and is applied to SV 1, 2 or 3. The exhaust at the rear of the solenoid is closed.

EDS 2, 3 AND 4 OPERATION

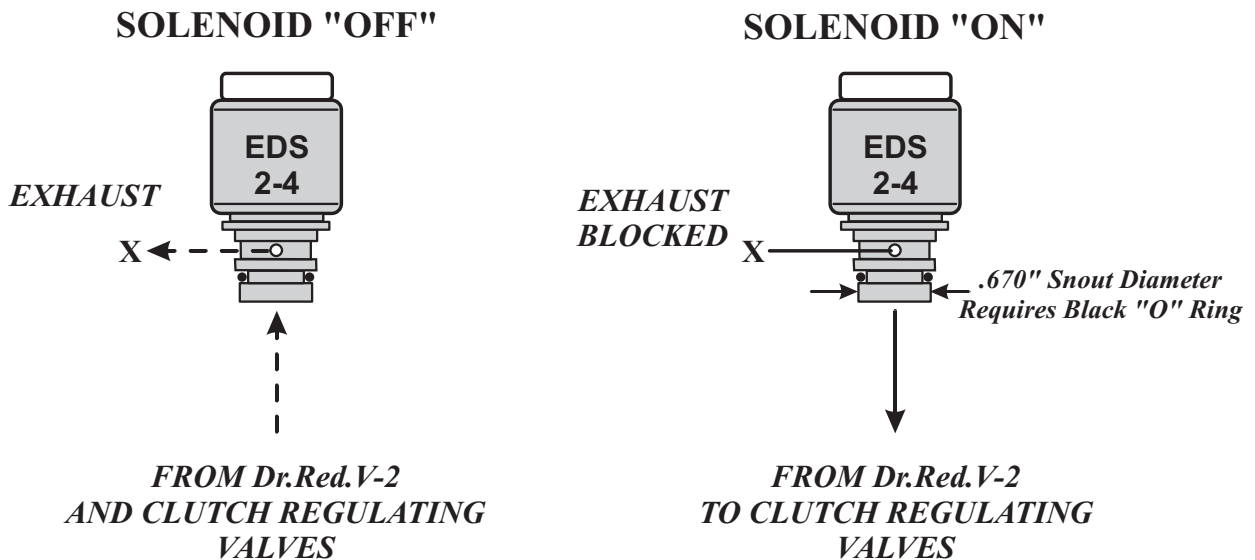

SUMMARY:

When EDS 2-4 solenoids are "OFF" they exhaust orificed solenoid reducing pressure, from Dr. Red. V-2, and the oil pressure from the clutch regulating valves releasing them.

When EDS 2-4 solenoids are "ON" the exhaust is blocked by the solenoid and solenoid reducing pressure, from Dr. Red. V-2, is applied to operate clutch regulating valves.

Copyright © 2003 ATSG

Figure 82

EDS-1 OPERATION
(Line Pressure Solenoid)

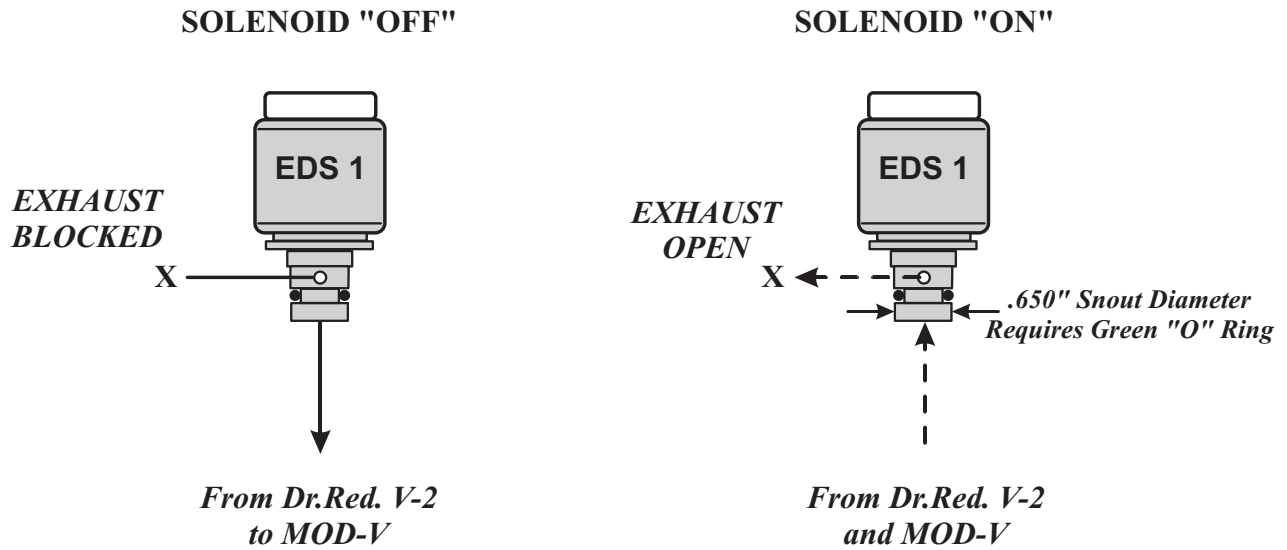

SUMMARY:

When EDS 1 solenoid is "OFF," solenoid reducing pressure, from Dr. Red. V-2, is high to MOD-V valve which creates high line pressure.

When EDS 1 solenoid is "ON," solenoid reducing pressure, from Dr. Red. V-2, is low to

Copyright © 2003 ATSG

Figure 83

ZF-5HP-19 INTERNAL WIRE SCHEMATIC

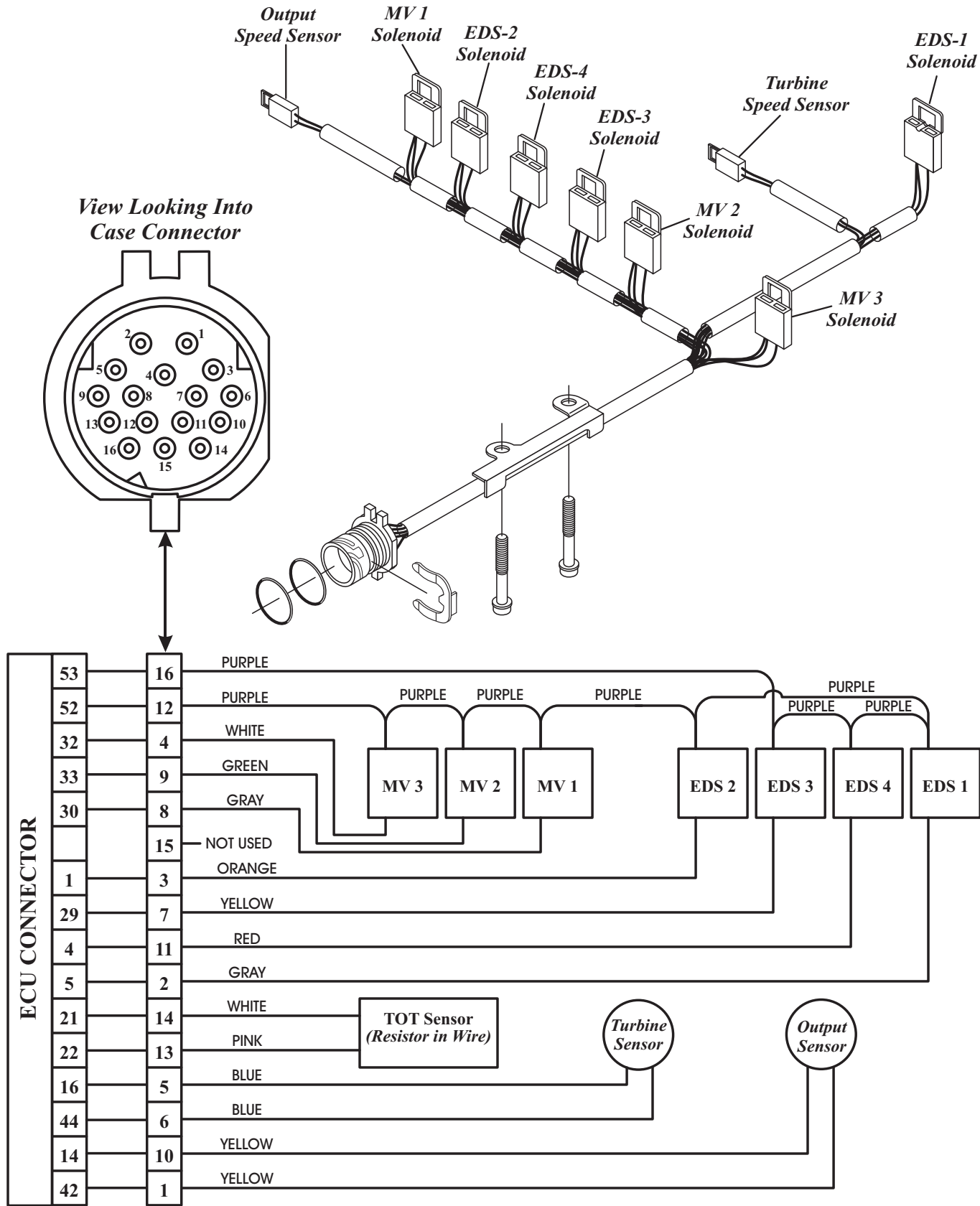

NOTE: Some internal wire colors may vary.

Copyright © 2003 ATSG

Figure 84

TECHNICIANS DIAGNOSTIC GUIDE BMW, AUDI, PORSCHE

ZF-5HP-19 SOLENOID APPLICATION CHART

<i>Selector Lever Position</i>	<i>MV 1 Solenoid</i>	<i>MV 2 Solenoid</i>	<i>MV 3 Solenoid</i>	<i>EDS 1 Solenoid</i>	<i>EDS 2 Solenoid</i>	<i>EDS 3 Solenoid</i>	<i>EDS 4 Solenoid</i>	GEAR RATIO
PARK	ON			**				
REVERSE	ON		⊗	**		*		4.08:1
NEUTRAL	ON	ON		**		*		
D-1ST	ON	ON		**		*		3.66:1
D-2ND	ON	ON		**	*	*		1.99:1
D-3RD		ON		**	*		-*-	1.40:1
D-4TH				**			-*-	1.00:1
D-5TH			-*	**	*		-*-	0.74:1
Failsafe (4th)	OFF	OFF	OFF	OFF	OFF	OFF	OFF	1.00:1

SOLENOID CHART LEGEND

<i>Symbol</i>	<i>Description</i>
ON	<i>MV 1, MV 2 and MV 3 Solenoids are energized by the Electronic Transmission Control unit and have two functions. They are Open or Closed. Energized (On), there is pressure in circuit.</i>
⊗	<i>MV 3 is turned "ON" if reverse is selected at a high vehicle speed, to inhibit reverse engagement.</i>
**	<i>EDS 1 is used for line pressure control only, and operates from 0 to 0.8 amps. When the solenoid is "OFF" (0 amps), pressure is high. EDS 1 pressure is "Lowered" as the solenoid is modulated by the control unit.</i>
*	<i>EDS 2, EDS 3, and EDS 4 Solenoids are also pulse modulated but are exactly the opposite of EDS 1 Solenoid. When these solenoids are "ON" oil pressure in the hydraulic circuit is high, and when they are "OFF" pressure in the hydraulic circuit is low.</i>
-*	<i>Solenoid "OFF" (hydraulic pressure low), then Solenoid "ON" (hydraulic pressure high).</i>
-*-	<i>EDS 4 Solenoid is used for Torque Converter Clutch apply and release only, and depends on throttle position and vehicle speed as to its application.</i>

Figure 85

TECHNICIANS DIAGNOSTIC GUIDE

BMW, AUDI, PORSCHE

ZF 5HP-19 SOLENOID AND SENSOR RESISTANCE CHART

<i>Solenoid</i>	<i>Case Connector</i>	<i>Control Unit Connector</i>	<i>Resistance In Ohms</i>
	<i>Pin Numbers</i> - +	<i>Pin Numbers</i> - +	
MV 1	8 and 12	30 and 52	30 - 34 Ω
MV 2	9 and 12	33 and 52	30 - 34 Ω
MV 3	4 and 12	32 and 52	30 - 34 Ω
EDS 1	2 and 12	5 and 52	5.2 - 6.8 Ω
EDS 2	3 and 12	1 and 52	6.2 - 7.8 Ω
EDS 3	7 and 12	29 and 52	6.2 - 7.8 Ω
EDS 4	11 and 12	4 and 52	6.2 - 7.8 Ω
TOT	13 and 14	21 and 22	1000 Ω at 25° C
OSS	1 and 10	14 and 42	292 - 358 Ω
TSS	5 and 6	44 and 16	292 - 358 Ω

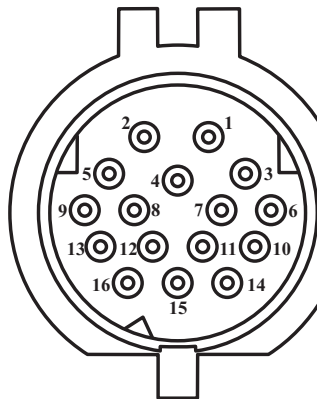

*View Looking Into
Case Connector*

Electronic Control Unit Connector Pin Identification

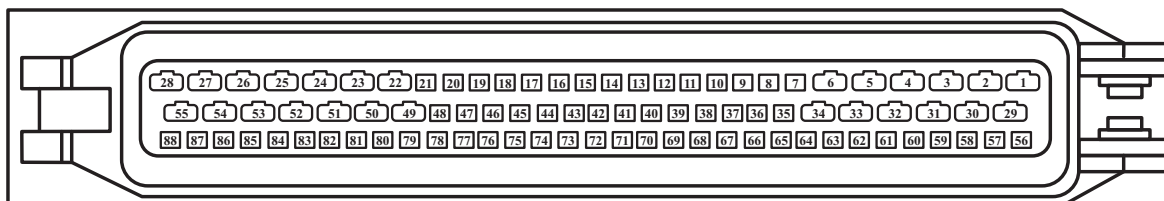
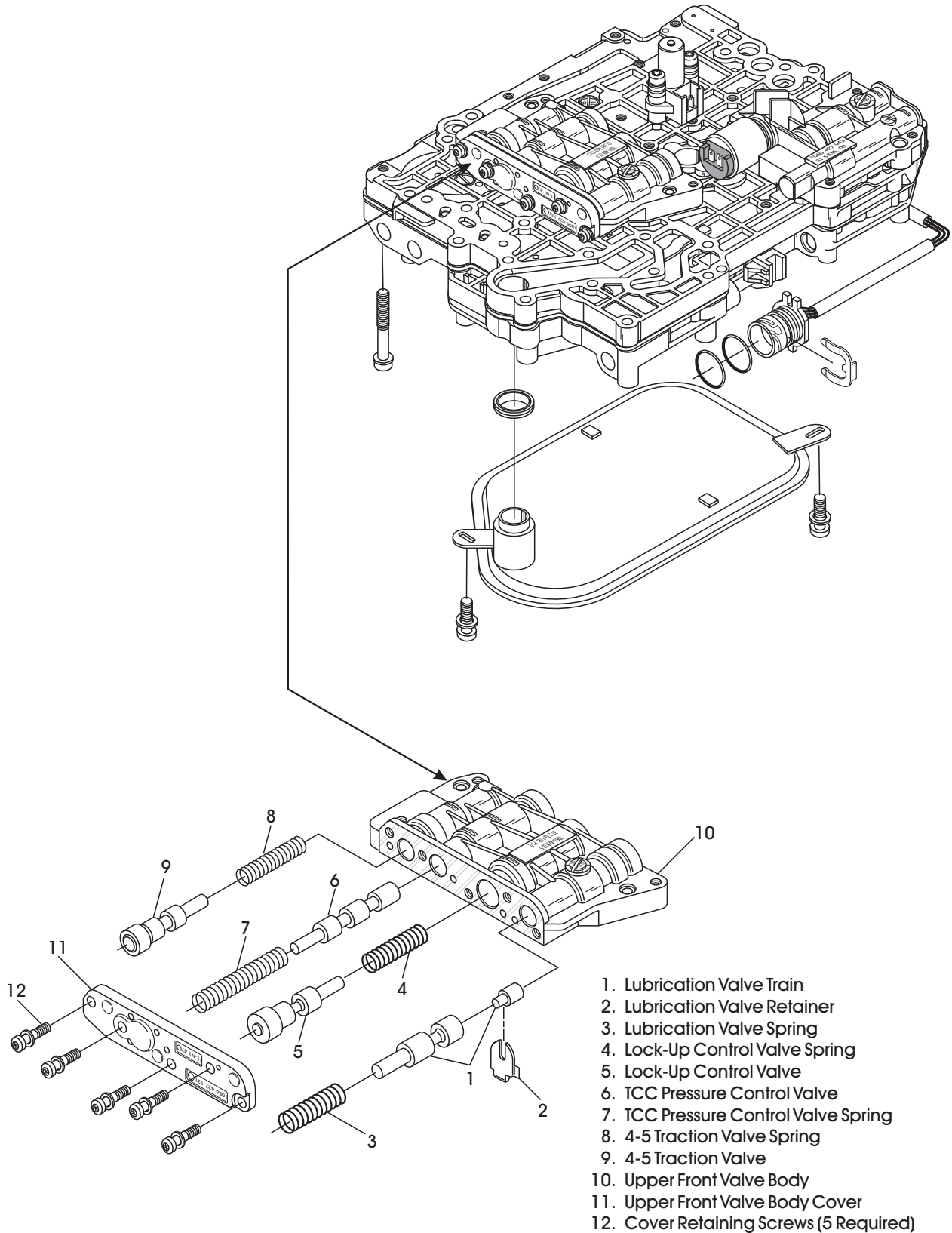

Figure 86

ZF-5HP-19FL
UPPER FRONT VALVE BODY



1. Lubrication Valve Train
2. Lubrication Valve Retainer
3. Lubrication Valve Spring
4. Lock-Up Control Valve Spring
5. Lock-Up Control Valve
6. TCC Pressure Control Valve
7. TCC Pressure Control Valve Spring
8. 4-5 Traction Valve Spring
9. 4-5 Traction Valve
10. Upper Front Valve Body
11. Upper Front Valve Body Cover
12. Cover Retaining Screws (5 Required)

Copyright © 2003 ATSG

Figure 87

ZF-5HP-19FL
UPPER REAR VALVE BODY

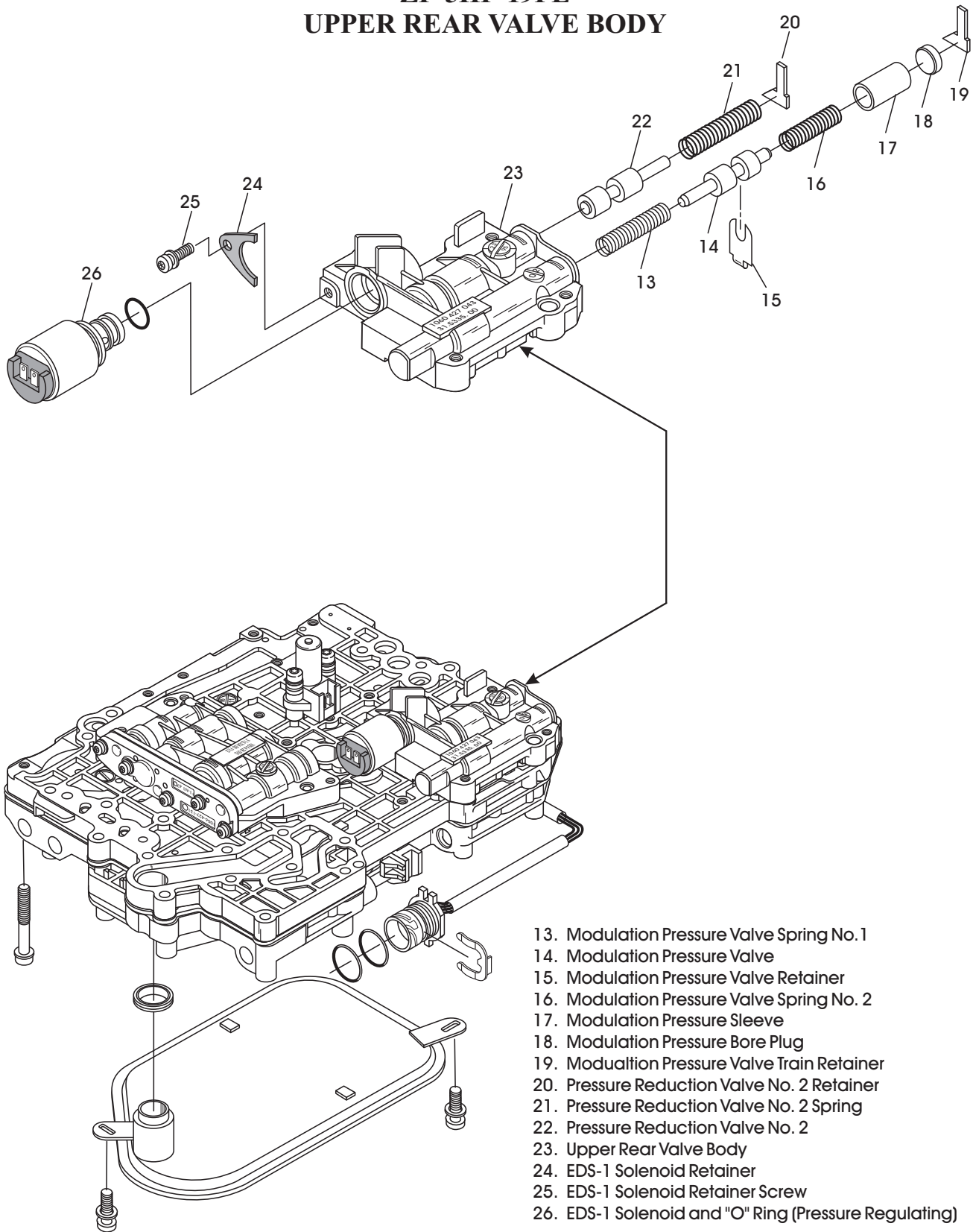

- 13. Modulation Pressure Valve Spring No.1
- 14. Modulation Pressure Valve
- 15. Modulation Pressure Valve Retainer
- 16. Modulation Pressure Valve Spring No. 2
- 17. Modulation Pressure Sleeve
- 18. Modulation Pressure Bore Plug
- 19. Modulation Pressure Valve Train Retainer
- 20. Pressure Reduction Valve No. 2 Retainer
- 21. Pressure Reduction Valve No. 2 Spring
- 22. Pressure Reduction Valve No. 2
- 23. Upper Rear Valve Body
- 24. EDS-1 Solenoid Retainer
- 25. EDS-1 Solenoid Retainer Screw
- 26. EDS-1 Solenoid and "O" Ring (Pressure Regulating)

Copyright © 2003 ATSG

Figure 88

ZF-5HP-19FL LOWER FRONT VALVE BODY

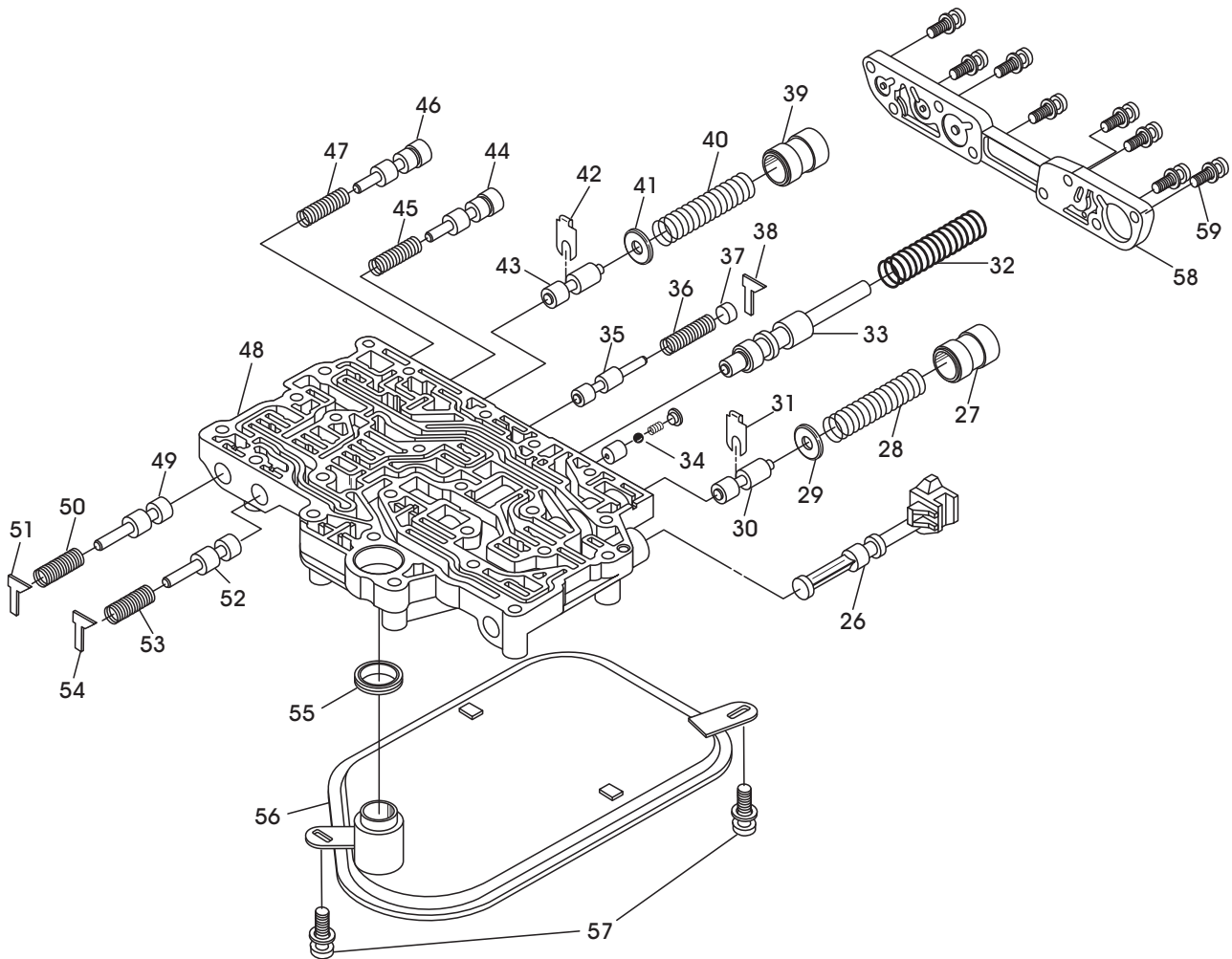

- | | |
|---|---|
| 26. Manual Shift Valve (W-S) | 43. "A" Clutch Accumulator Regulator Valve |
| 27. "E" Clutch Damper Valve | 44. "G" Clutch Accumulator Regulator Valve |
| 28. "E" Clutch Damper Valve Spring | 45. "G" Clutch Accumulator Regulator Valve Spring |
| 29. "E" Clutch Damper Valve Spring Seat | 46. "C" Clutch Accumulator Regulator Valve |
| 30. "E" Clutch Accumulator Regulator Valve | 47. "C" Clutch Accumulator Regulator Valve Spring |
| 31. "E" Clutch Accumulator Regulator Valve Retainer | 48. Lower Front Valve Body |
| 32. Main Pressure Regulator Valve Spring | 49. "C" Clutch Shift Valve |
| 33. Main Pressure Regulator Valve | 50. "C" Clutch Shift Valve Spring |
| 34. "D" Clutch One-Way Check Valve Assembly | 51. "C" Clutch Shift Valve Retainer |
| 35. 5-4 Traction Valve | 52. "G" Clutch Shift Valve |
| 36. 5-4 Traction Valve Spring | 53. "G" Clutch Shift Valve Spring |
| 37. 5-4 Traction Valve Bore Plug | 54. "G" Clutch Shift Valve Retainer |
| 38. 5-4 Traction Valve Train Retainer | 55. Filter Seal |
| 39. "A" Clutch Damper Valve | 56. Oil Filter |
| 40. "A" Clutch Damper Valve Spring | 57. Oil Filter Retaining Screws |
| 41. "A" Clutch Damper Valve Spring Seat | 58. Lower Valve Body Cover |
| 42. "A" Clutch Accumulator Regulator Valve Retainer | 59. Lower Valve Body Cover Screws (8 Required) |

Copyright © 2003 ATSG

Figure 89

ZF-5HP-19FL LOWER REAR VALVE BODY

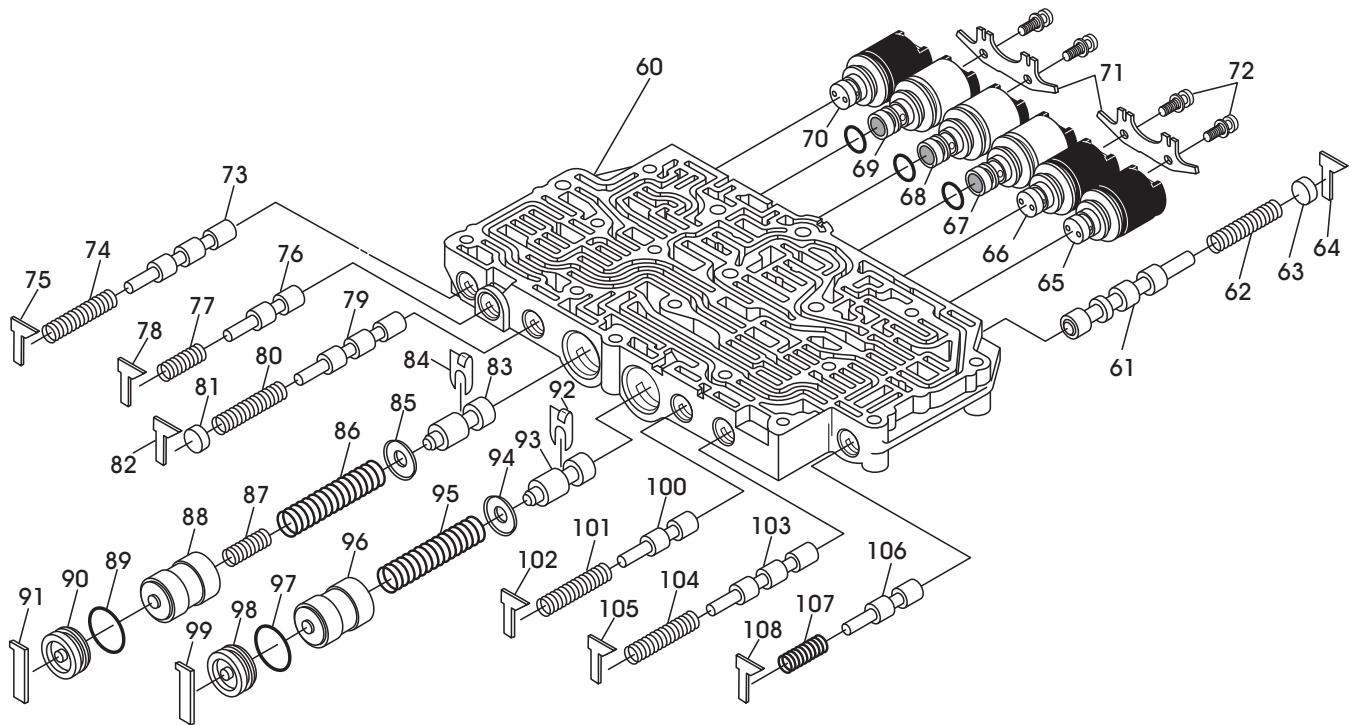

- | | |
|---|---|
| 60. Lower Rear Valve Body | 85. "D" Clutch Damper Valve Spring Seat |
| 61. Number 1 Shift Valve | 86. "D" Clutch Damper Valve Outer Spring |
| 62. Number 1 Shift Valve Spring | 87. "D" Clutch Damper Valve Inner Spring |
| 63. Number 1 Shift Valve Bore Plug | 88. "D" Clutch Damper Valve |
| 64. Number 1 Shift Valve Retainer | 89. "D" Clutch Valve Train Bore Plug "O" Ring |
| 65. MV-3 Solenoid (On-Off) | 90. "D" Clutch Valve Train Bore Plug |
| 66. MV-2 Solenoid (On-Off) | 91. "D" Clutch Valve Train Bore Plug Retainer |
| 67. EDS-3 Solenoid and "O" Ring (Pressure Regulating) | 92. "F" Clutch Accumulator Regulator Valve Retainer |
| 68. EDS-4 Solenoid and "O" Ring (Pressure Regulating) | 93. "F" Clutch Accumulator Regulator Valve |
| 69. EDS-2 Solenoid and "O" Ring (Pressure Regulating) | 94. "F" Clutch Damper Valve Spring Seat |
| 70. MV-1 Solenoid (On-Off) | 95. "F" Clutch Damper Valve Spring |
| 71. Solenoid Retaining Brackets (2 Required) | 96. "F" Clutch Damper Valve |
| 72. Solenoid Retaining Bracket Screws (4 Required) | 97. "F" Clutch Valve Train Bore Plug "O" Ring |
| 73. Traction Coast Valve | 98. "F" Clutch Valve Train Bore Plug |
| 74. Traction Coast Valve Spring | 99. "F" Clutch Valve Train Bore Plug Retainer |
| 75. Traction Coast Valve Train Retainer | 100. Reverse Gear Valve |
| 76. TCC Release Regulator Valve | 101. Reverse Gear Valve Spring |
| 77. TCC Release Regulator Valve Spring | 102. Reverse Gear Valve Train Retainer |
| 78. TCC Release Regulator Valve Train Retainer | 103. Number 2 Shift Valve |
| 79. Number 3 Shift Valve | 104. Number 2 Shift Valve Spring |
| 80. Number 3 Shift Valve Spring | 105. Number 2 Shift Valve Train Retainer |
| 81. Number 3 Shift Valve Train Bore Plug | 106. Pressure Reduction Valve |
| 82. Number 3 Shift Valve Train Retainer | 107. Pressure Reduction Valve Spring |
| 83. "D" Clutch Accumulator Regulator Valve | 108. Pressure Reduction Valve Train Retainer |
| 84. "D" Clutch Accumulator Regulator Valve Retainer | |

Copyright © 2003 ATSG

Figure 90

ZF-5HP-19FL
TRANSFER PLATE, SPACER PLATE, AND
TURBINE SPEED SENSOR

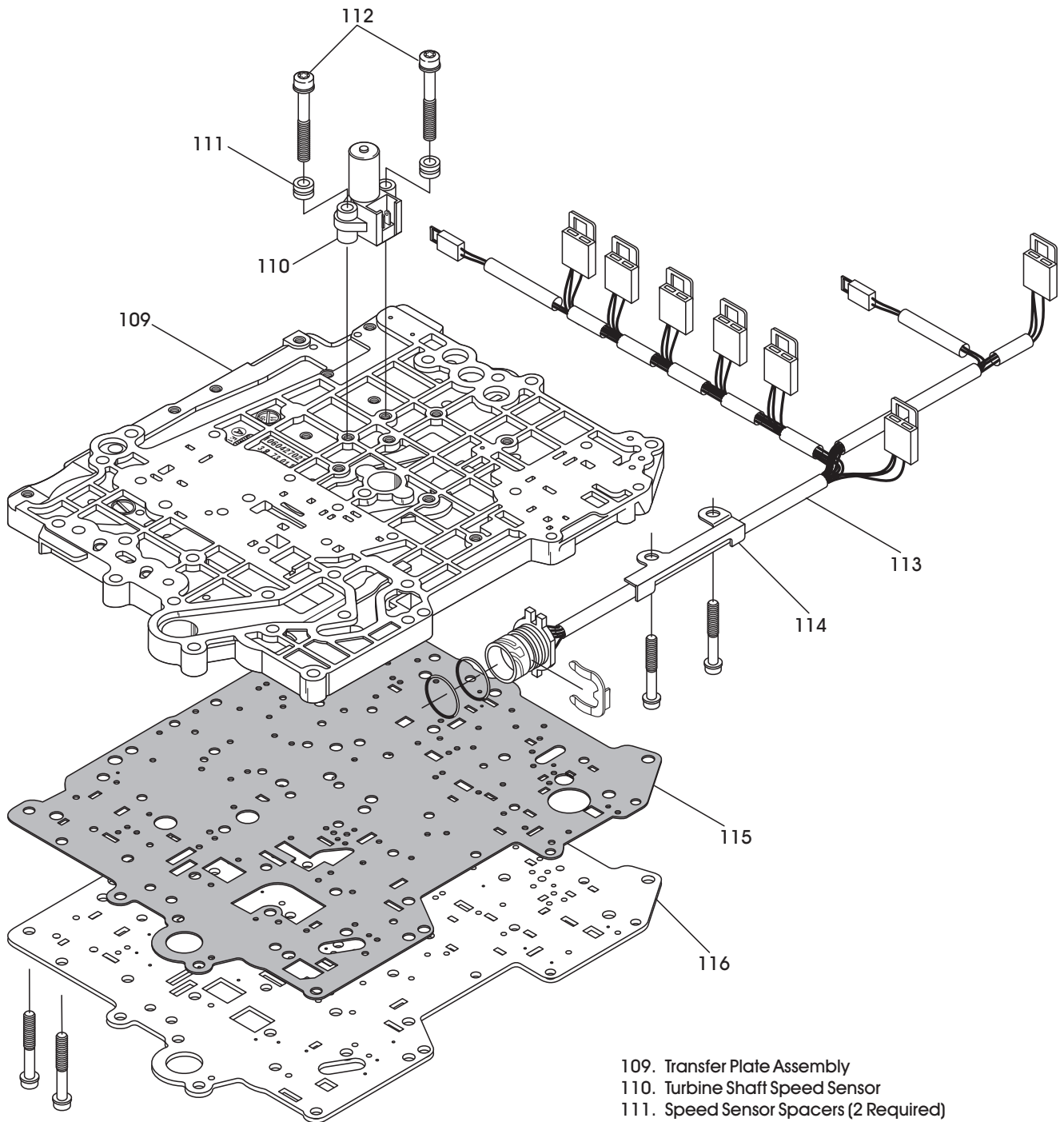

- 109. Transfer Plate Assembly
- 110. Turbine Shaft Speed Sensor
- 111. Speed Sensor Spacers (2 Required)
- 112. Speed Sensor Retaining Bolts (2 Required)
- 113. Internal Wiring Harness Assembly
- 114. Internal Wire Harness Retaining Bracket
- 115. Spacer Plate To Transfer Plate Gasket
- 116. Valve Body Spacer Plate

Copyright © 2003 ATSG

Figure 91

ZF-5HP-19FL
LOWER FRONT VALVE BODY

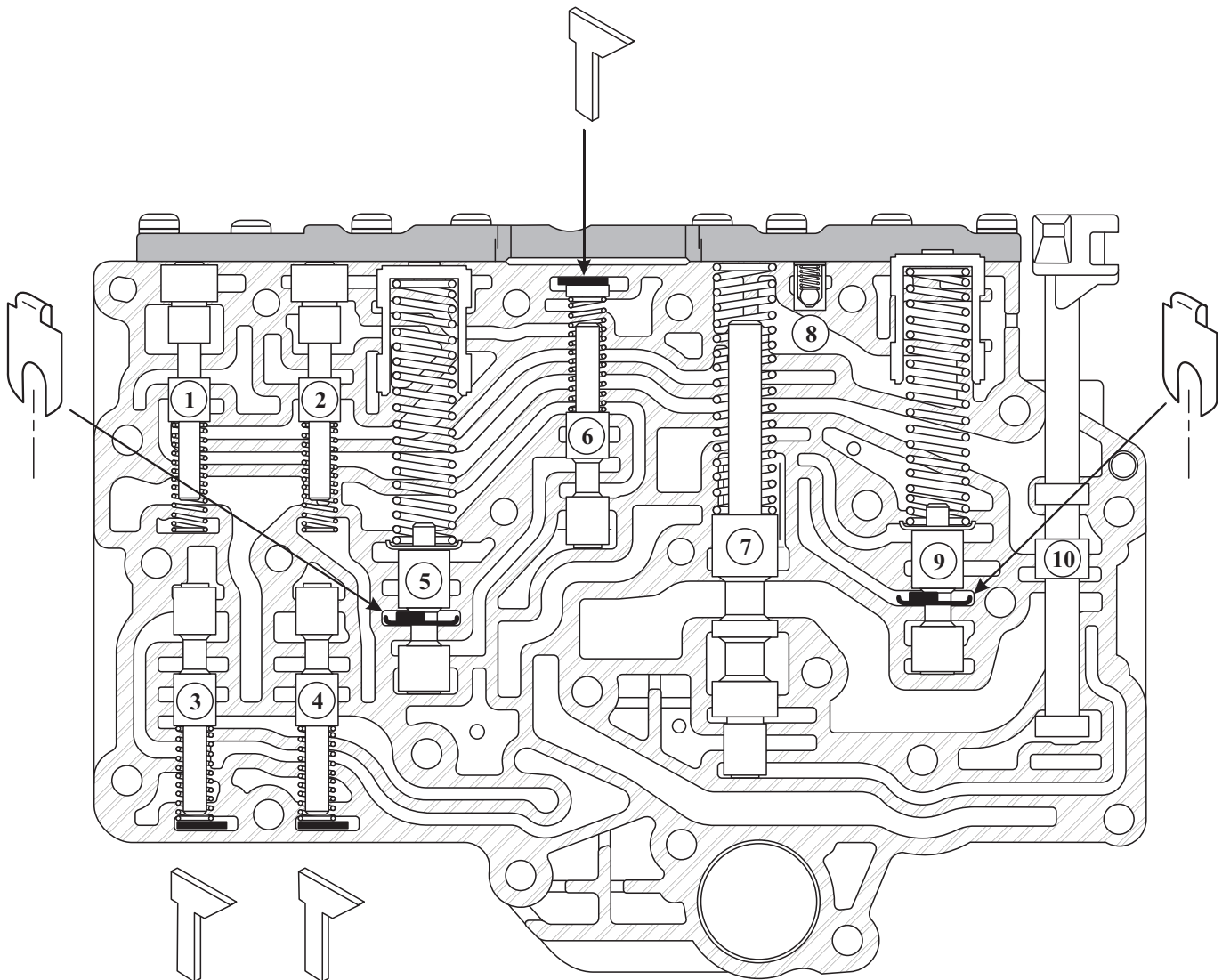

1. "C" CLUTCH ACCUMULATOR REGULATOR VALVE TRAIN LINE-UP.
2. "G" CLUTCH ACCUMULATOR REGULATOR VALVE TRAIN LINE-UP.
3. "C" CLUTCH SHIFT VALVE TRAIN LINE-UP.
4. "G" CLUTCH SHIFT VALVE TRAIN LINE-UP.
5. "A" CLUTCH ACCUMULATOR REGULATOR VALVE TRAIN LINE-UP.
6. 5-4 TRACTION VALVE TRAIN LINE-UP.
7. MAIN PRESSURE REGULATOR VALVE TRAIN LINE-UP.
8. "D" CLUTCH ONE-WAY CHECK VALVE ASSEMBLY.
9. "E" CLUTCH ACCUMULATOR REGULATOR VALVE TRAIN LINE-UP.
10. MANUAL SELECTOR SHIFT VALVE.

Copyright © 2003 ATSG

Figure 92

ZF-5HP-19FL
UPPER FRONT VALVE BODY

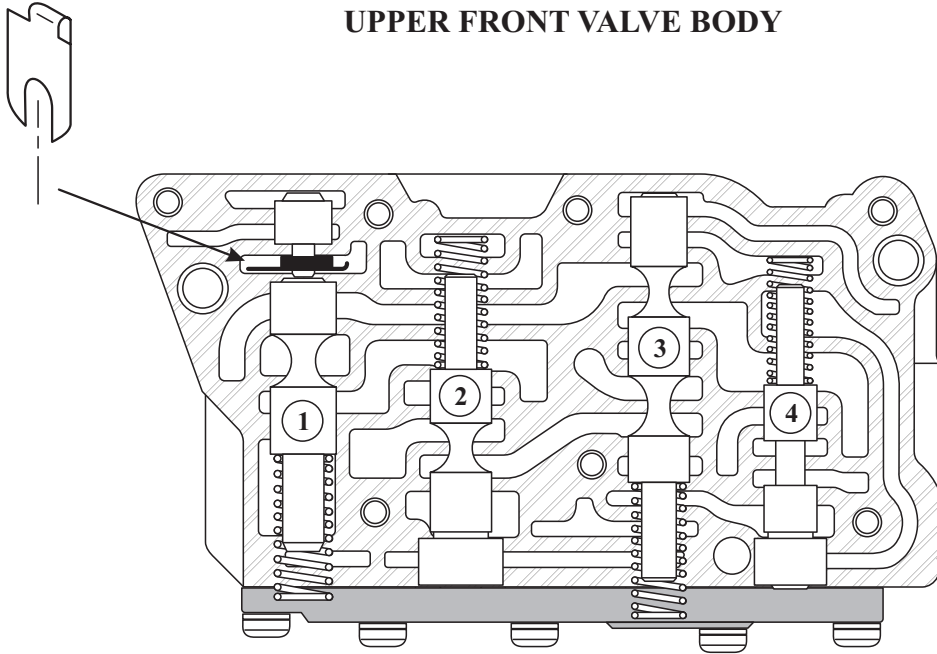

1. LUBRICATION VALVE TRAIN LINE-UP.
2. LOCK-UP CONTROL VALVE TRAIN LINE-UP.
3. LOCK-UP PRESSURE CONTROL VALVE LINE-UP.
4. 4-5 TRACTION VALVE TRAIN LINE-UP.

ZF-5HP-19FL
UPPER REAR VALVE BODY

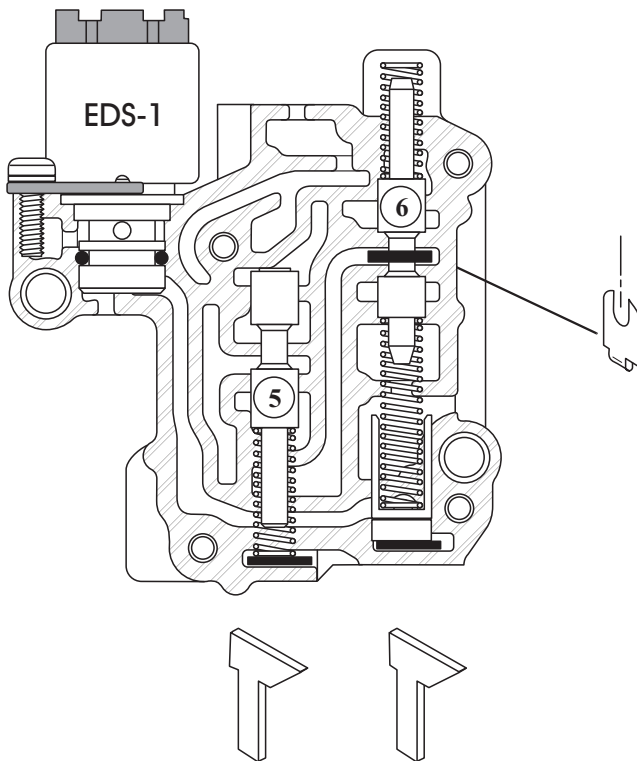

5. MODULATION PRESSURE VALVE TRAIN LINE-UP.
6. PRESSURE REDUCTION VALVE NUMBER TWO LINE-UP.

Copyright © 2003 ATSG

Figure 93

ZF-5HP-19FL
LOWER REAR VALVE BODY

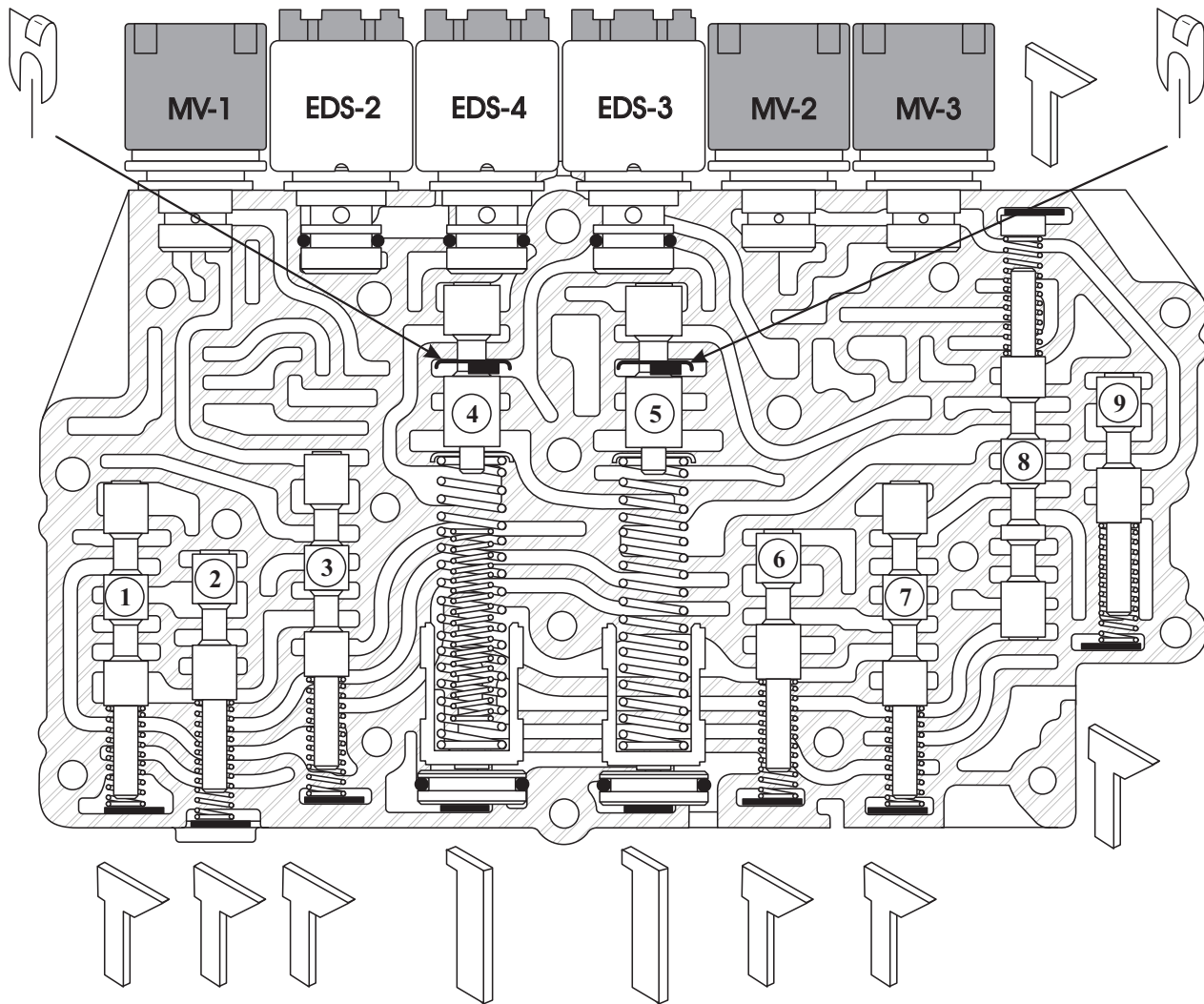

1. TRACTION COAST VALVE TRAIN LINE-UP.
2. TCC RELEASE REGULATOR VALVE TRAIN LINE-UP.
3. NUMBER 3 SHIFT VALVE TRAIN LINE-UP.
4. "D" CLUTCH ACCUMULATOR REGULATOR VALVE TRAIN LINE-UP.
5. "F" CLUTCH ACCUMULATOR REGULATOR VALVE TRAIN LINE-UP.
6. REVERSE GEAR VALVE TRAIN LINE-UP.
7. NUMBER 2 SHIFT VALVE TRAIN LINE-UP.
8. NUMBER 1 SHIFT VALVE TRAIN LINE-UP.
9. PRESSURE REDUCTION VALVE TRAIN LINE-UP.

Copyright © 2003 ATSG

Figure 94

ZF-5HP-19FL CHANNEL PLATE LOCATIONS

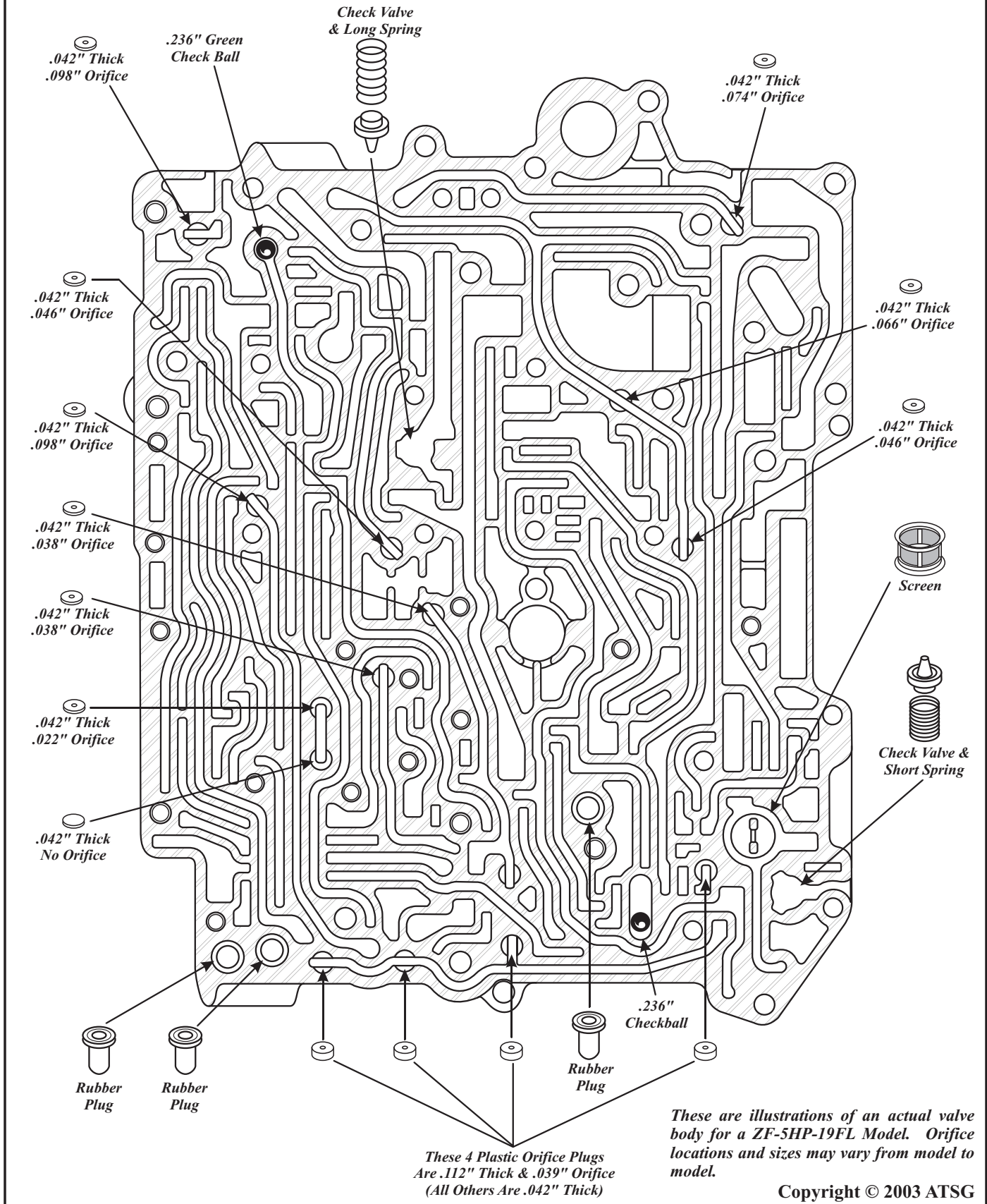

Figure 95



TECHNICIANS DIAGNOSTIC GUIDE

BMW, AUDI, PORSCHE

ZF 5HP-19FL SPRING SPECIFICATIONS

UPPER FRONT VALVE BODY

SPRING ILLUSTRATION NO. 3:
FREE LENGTH = 1.540"
SPRING DIAMETER = .419"
WIRE DIAMETER = .048"

SPRING ILLUSTRATION NO. 4:
FREE LENGTH = 1.712"
SPRING DIAMETER = .423"
WIRE DIAMETER = .043"

SPRING ILLUSTRATION NO. 7:
FREE LENGTH = 2.090"
SPRING DIAMETER = .432"
WIRE DIAMETER = .035"

SPRING ILLUSTRATION NO. 8:
FREE LENGTH = 1.482"
SPRING DIAMETER = .367"
WIRE DIAMETER = .027"

UPPER REAR VALVE BODY

SPRING ILLUSTRATION NO. 13:
FREE LENGTH = 1.632"
SPRING DIAMETER = .300"
WIRE DIAMETER = .027"

SPRING ILLUSTRATION NO. 16:
FREE LENGTH = 1.462"
SPRING DIAMETER = .315"
WIRE DIAMETER = .046"

SPRING ILLUSTRATION NO. 21:
FREE LENGTH = 1.987"
SPRING DIAMETER = .375"
WIRE DIAMETER = .042"

LOWER FRONT VALVE BODY

SPRING ILLUSTRATION NO. 28:
FREE LENGTH = 3.438"
SPRING DIAMETER = .567"
WIRE DIAMETER = .038"

SPRING ILLUSTRATION NO. 32:
FREE LENGTH = 3.730"
SPRING DIAMETER = .606"
WIRE DIAMETER = .077"

SPRING ILLUSTRATION NO. 36:
FREE LENGTH = 1.702"
SPRING DIAMETER = .365"
WIRE DIAMETER = .031"

SPRING ILLUSTRATION NO. 40:
FREE LENGTH = 3.102"
SPRING DIAMETER = .590"
WIRE DIAMETER = .042"

SPRING ILLUSTRATION NO. 45 & 47:
FREE LENGTH = 1.430"
SPRING DIAMETER = .365"
WIRE DIAMETER = .031"

SPRING ILLUSTRATION NO. 50 & 53:
FREE LENGTH = 1.690"
SPRING DIAMETER = .375"
WIRE DIAMETER = .042"

Note: The spring illustration numbers refer to the ATSG illustrations in this manual.

Note: ZF is now working on a "Valve Body Kit" for the 5HP-19 that includes all new stock springs, all check balls, all orifices and screens, but was not ready at the time of this printing.

LOWER REAR VALVE BODY

SPRING ILLUSTRATION NO. 62:
FREE LENGTH = 1.825"
SPRING DIAMETER = .367"
WIRE DIAMETER = .031"

SPRING ILLUSTRATION 74:
FREE LENGTH = 1.832"
SPRING DIAMETER = .367"
WIRE DIAMETER = .031"

SPRING ILLUSTRATION NO. 77:
FREE LENGTH = 1.439"
SPRING DIAMETER = .365"
WIRE DIAMETER = .031"

SPRING ILLUSTRATION NO. 80:
FREE LENGTH = 1.832"
SPRING DIAMETER = .367"
WIRE DIAMETER = .031"

SPRING ILLUSTRATION NO. 86:
FREE LENGTH = 2.925"
SPRING DIAMETER = .640"
WIRE DIAMETER = .049"

SPRING ILLUSTRATION NO. 87:
FREE LENGTH = 1.595"
SPRING DIAMETER = .422"
WIRE DIAMETER = .035"

SPRING ILLUSTRATION NO. 95:
FREE LENGTH = 3.818"
SPRING DIAMETER = .590"
WIRE DIAMETER = .044"

SPRING ILLUSTRATION NO. 101:
FREE LENGTH = 1.825"
SPRING DIAMETER = .367"
WIRE DIAMETER = .031"

SPRING ILLUSTRATION NO. 104:
FREE LENGTH = 1.825"
SPRING DIAMETER = .367"

SPRING ILLUSTRATION NO. 107:
FREE LENGTH = 1.506"
SPRING DIAMETER = .381"
WIRE DIAMETER = .043"

Copyright © 2003 ATSG

Figure 96

**ZF-5HP-24
DIAGNOSTIC INFORMATION**

FOUND IN:

- BMW 5 Series E39, 7 Series E38, 8 Series E31 95-Current*
- Jaguar XK8 (X100), 96-Current*
- Jaguar XJ8 (X300), 97-Current*
- Audi A8 (All Wheel Drive 5HP-24A) 96-Current*

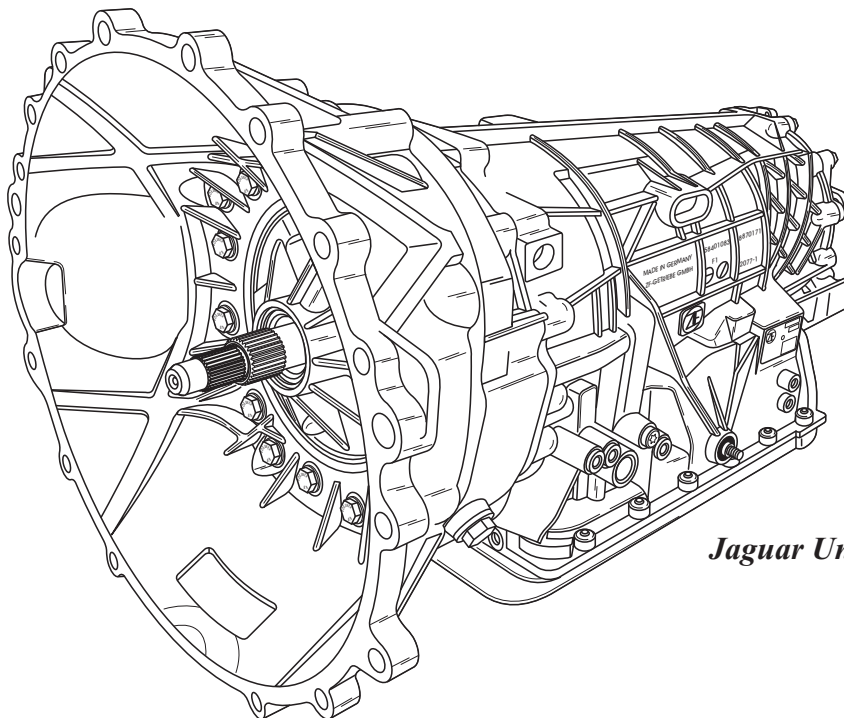

Jaguar Unit Shown

This transmission is manufactured in Germany by ZF and carries the BMW designation A5S 440Z.

The A5S 440Z is an electronically controlled, five speed automatic transmission with a lock-up clutch type torque converter. Three planetary gear sets (Wilson Gearing), three rotating multiple disc clutches, three multiple disc brake clutches, and one sprag clutch (Freewheel) are used to provide the five forward speeds and reverse.

Key to designation:

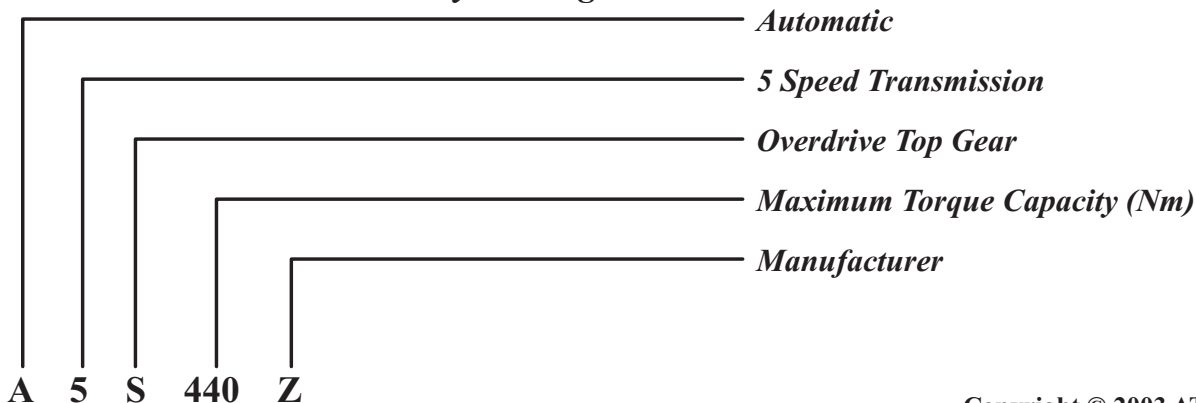

Figure 97



TECHNICIANS DIAGNOSTIC GUIDE BMW, AUDI, PORSCHE

Refer to Figure 98 for Clutch and Band Application Chart.

Refer to Figure 99 for Manual Shift Lever Operation, and Failsafe Operation.

Refer to Figures 100, and 101 for Solenoid identification and both MV Solenoid Operation and EDS Solenoid Operation and Tests.

Refer to Figure 102 for wiring harness identification, internal wiring schematic, and transmission case connector pin identification and functions.

Refer to Figure 103 for Shift Solenoid Application chart. Notice that EDS 1 Solenoid is used for line pressure control, and MV-4 is used for converter clutch.

Refer to Figure 104 for EDS Solenoid "Principles of Operation", as some are normally open and some are normally closed.

Refer to Figure 105 for internal components resistance chart, with the pins identified for both the transmission case connector and the Electronic Control Unit.

Refer to Figure 106 for Upper Valve Body exploded view and identification of valves.

Refer to Figure 107 for Lower Front Valve Body exploded view and identification of valves.

Refer to Figure 108 for Lower Rear Valve Body exploded view and identification of valves.

Refer to Figures 109, 110, and 111 for valve body retainer locations in the various valve bodies.

Refer to Figure 112 for Channel Plate screen location on the upper side.

Refer to Figure 113 for the locations of the orifices, checkballs, screens, and the check valves and springs that are located in the channel plate.

Refer to Figure 114 for external pressure tap locations in the main case.

Refer to Figure 115 for Pump Volume Control Valve location, in the pump cover.

Refer to Figure 116 for explanation of Pump Volume Control Valve operation.

Refer to Figure 119 for all valve body spring specifications, as observed in a used valve body.

ZF-5HP-24 INTERNAL COMPONENT APPLICATION CHART

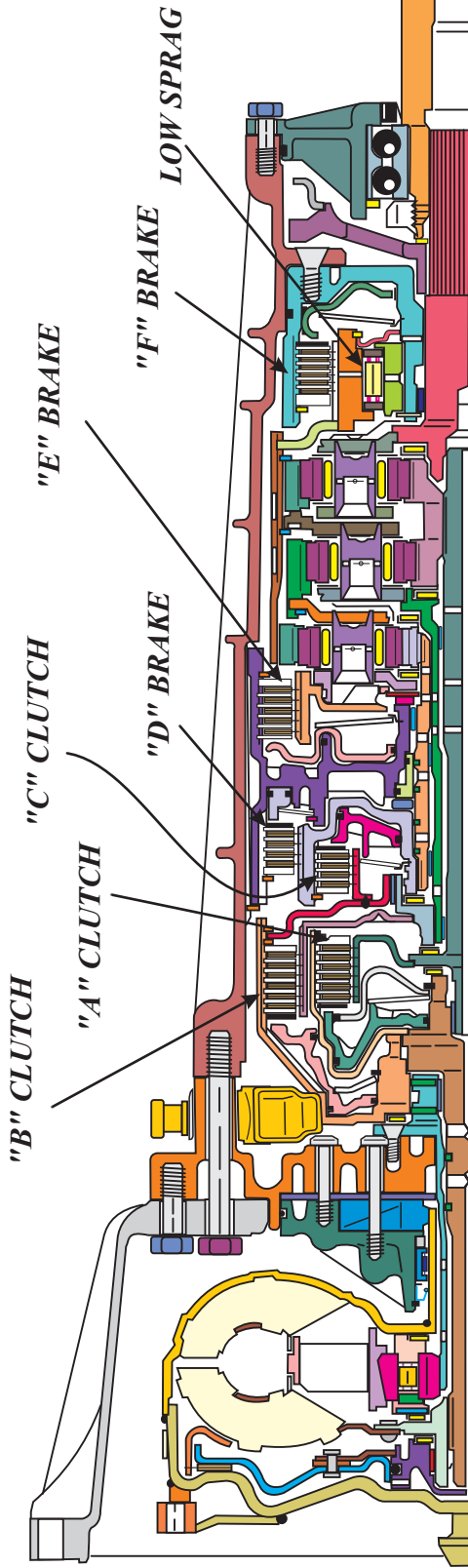

APPLICATION CHART

GEAR	"A" CLUT	"B" CLUT	"C" CLUT	"D" BRAK	"E" BRAK	"F" BRAK	LOW SPRAG	GEAR RATIO
PARK						ON		
REV			ON			ON		4.10:1
NEUT						ON		
D-1ST	ON						HOLD	3.57:1
D-2ND	ON				ON			2.20:1
D-3RD	ON			ON				1.51:1
D-4TH	ON	ON						1.00:1
D-5TH		ON		ON				0.80:1
M-1	ON					ON	HOLD	3.57:1

Figure 98



TECHNICIANS DIAGNOSTIC GUIDE BMW, AUDI, PORSCHE

SELECTOR LEVER POSITIONS

P = *Park*, and should only be selected when the vehicle is at a standstill. First apply the hand brake, and then select the Park position with the manual lever. Refer to Figure 99.

R = *Reverse*, and should only be selected when the vehicle is at a standstill with engine at idle. Refer to Figure 99.

N = *Neutral*, and may be selected when the vehicle is at a standstill, but first applying the handbrake. May also be selected while vehicle is moving, to restart the engine or to counteract a skidding concern. Refer to Figure 99.

D = *Drive*, is the standard position for normal driving in the XE program (AGS) and provides automatic upshifts from 1st to 5th and automatic downshifts from 5th to 1st gear. The adaptive transmission control (AGS) system contains various driving programs such as Stop and Go, Trailer Towing, Mountain Driving, City Driving and Highway Driving (constant speed). These programs are selected by the Electronic Control Unit (ECU), which automatically modifies the transmissions shift characteristics according to rolling resistance, engine load, accelerator pedal movement and vehicle speed. The standard "Drive" position is position "1", as shown in Figure 99.

"S" - Program

The "S" Program is a performance oriented program, where the gear changing characteristics of the transmission are moved up to higher engine speeds. To select the "S" Program, the selector lever is shifted to the left-hand gate (position "2" in Figure 99), without moving shift lever towards plus or minus. The "S" Program provides automatic upshifts from 1st to 4th and automatic downshifts from 4th to 1st gear. 5th gear is inhibited when the "S" Program is selected.

"M" - Program

The "M" Program is a manual shift program which is activated by simply pushing the selector lever towards the minus sign for sequential downshifts and towards the plus sign for sequential upshifts, while the shift lever is in the left-hand gate (position "2" in Figure 99). It is possible to drive off in 1st gear, 2nd gear or 3rd gear, however, 4th gear can be manually selected only at a speed of approximately 40 km per hour and 5th gear at approximately 60 km per hour.

4th Gear, Select this position if the transmission tends to hunt between 5th-4th/4th-5th gears under certain driving conditions.

3rd Gear, Select this position if the transmission tends to hunt between 3rd and 5th gears under certain driving conditions. Also recommended for lengthy descents in mountainous areas.

2nd Gear, Select this position when driving over mountain passes with lengthy ascents and descents.

1st Gear, This position can be selected for engine braking effect, depending on vehicle speed.

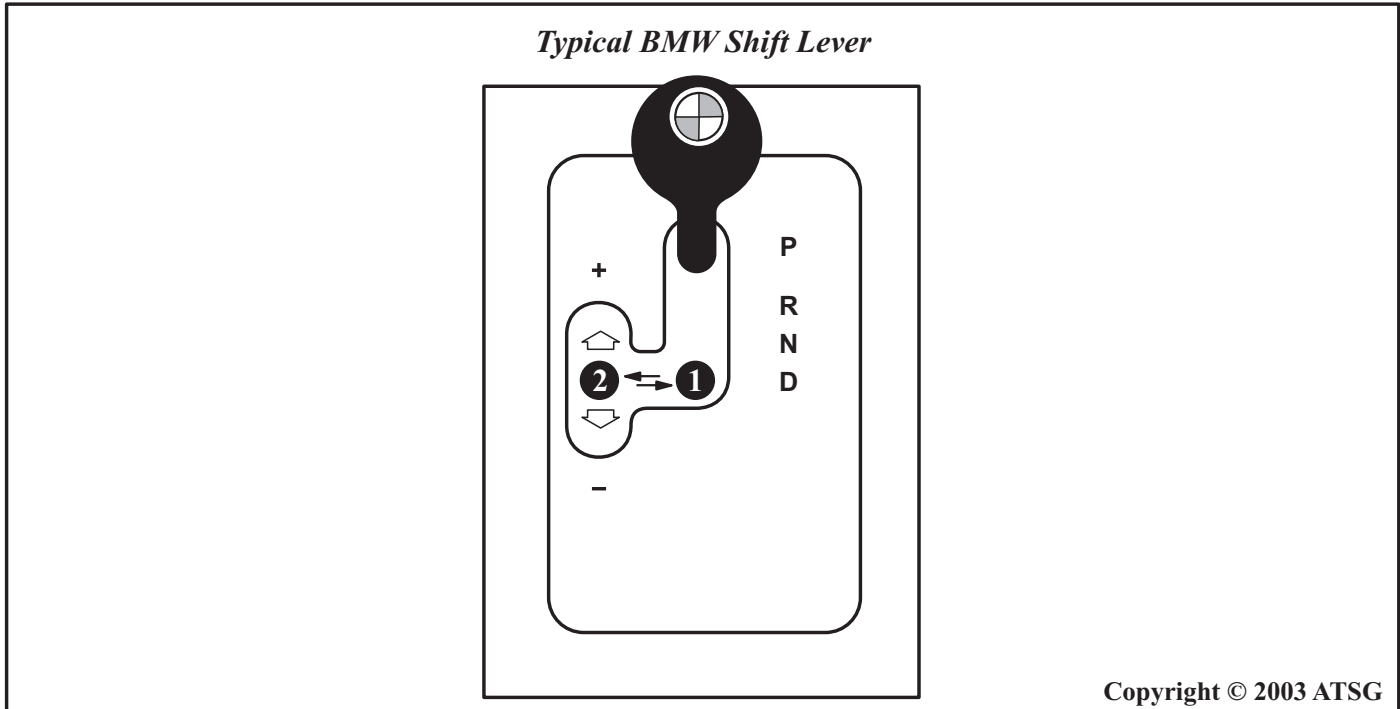

Figure 99

FAILSAFE OPERATION:

When a system fault is detected which would impair normal reliable operation, the transmission control module interrupts the power supply to Pin 12 at the transmission case connector. The transmission control module also alerts the driver of any faults by signaling the vehicle's "check control" system. To enable the vehicle to be driven to a repair shop, the following manual gear selections are permitted:

<i>Selector Lever Position</i>	P R N D 4 3 2
<i>Actual Gear Obtained</i>	P R N 5 5 5 5

MV1, 2 AND 3

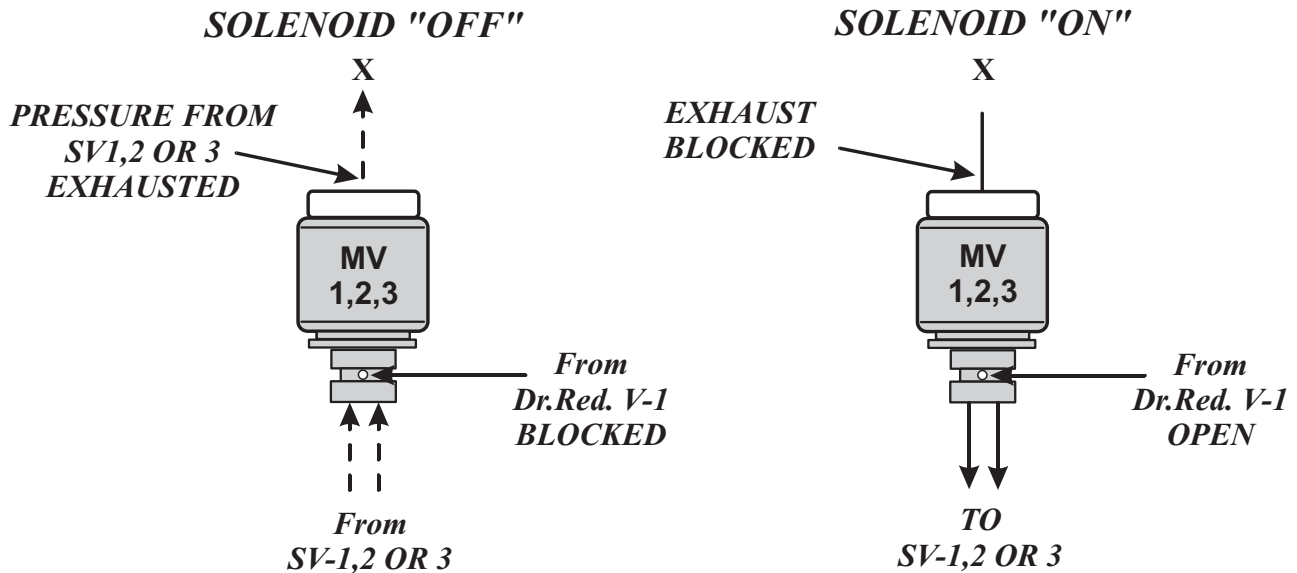

SUMMARY:

*When MV 1, 2 or 3 is "OFF" Solenoid reducing pressure, from Dr.Red. V-1, is blocked by the solenoid and oil pressure from SV 1, 2 or 3 is exhausted at the rear of the solenoid.
When MV 1, 2 or 3 is "ON" Solenoid reducing pressure, From Dr.Red. V-1, is open through the solenoid and is applied to SV 1, 2 or 3. The exhaust at the rear of the solenoid is closed.*

EDS 2, 3, 4, 5,

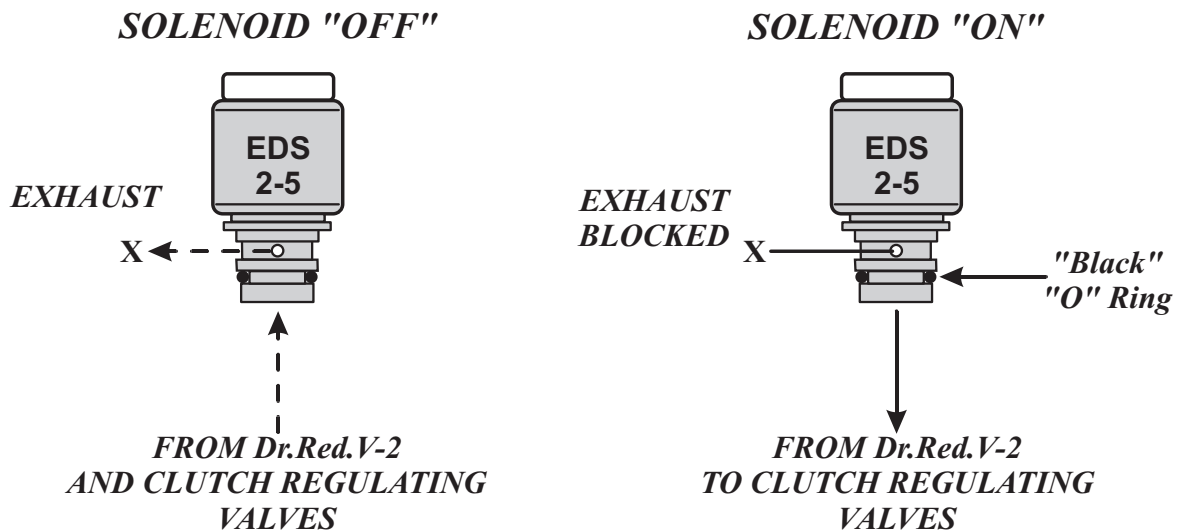

SUMMARY:

*When EDS 2 thru 5 solenoids are "OFF" they exhaust orificed solenoid reducing pressure, from Dr. Red. V-2, and the oil pressure from the clutch regulating valves releasing them.
When EDS 2 thru 5 solenoids are "ON" the exhaust is blocked by the solenoid and solenoid reducing pressure, from Dr. Red. V-2, is applied to operate clutch regulating valves.*

Figure 100

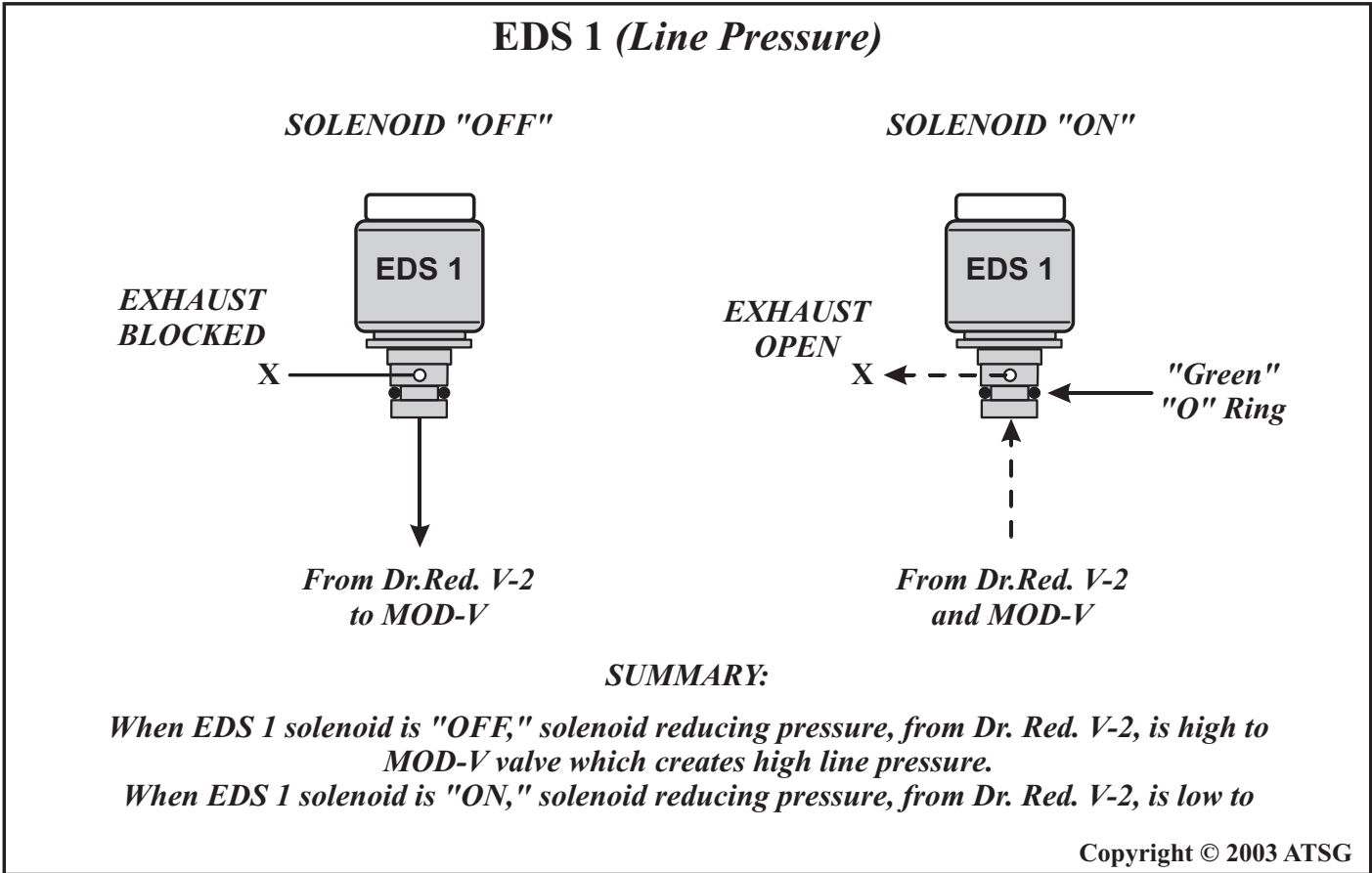
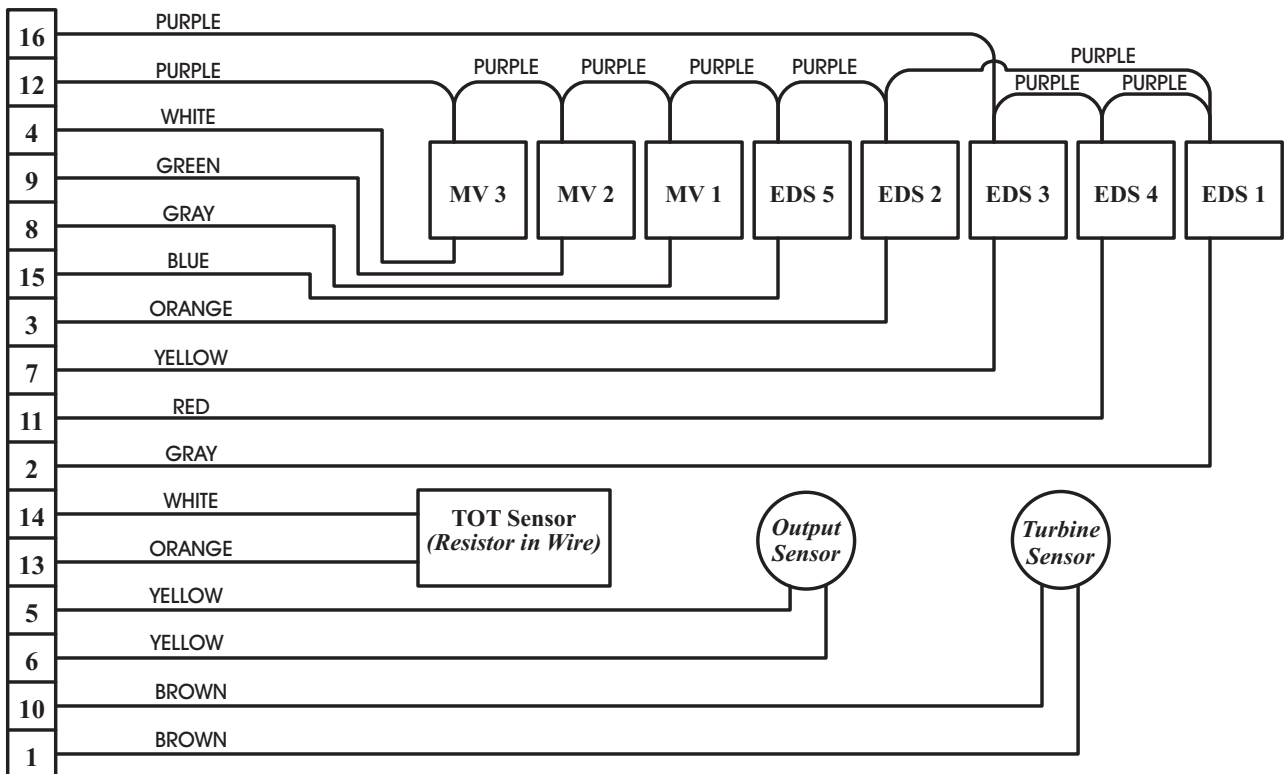
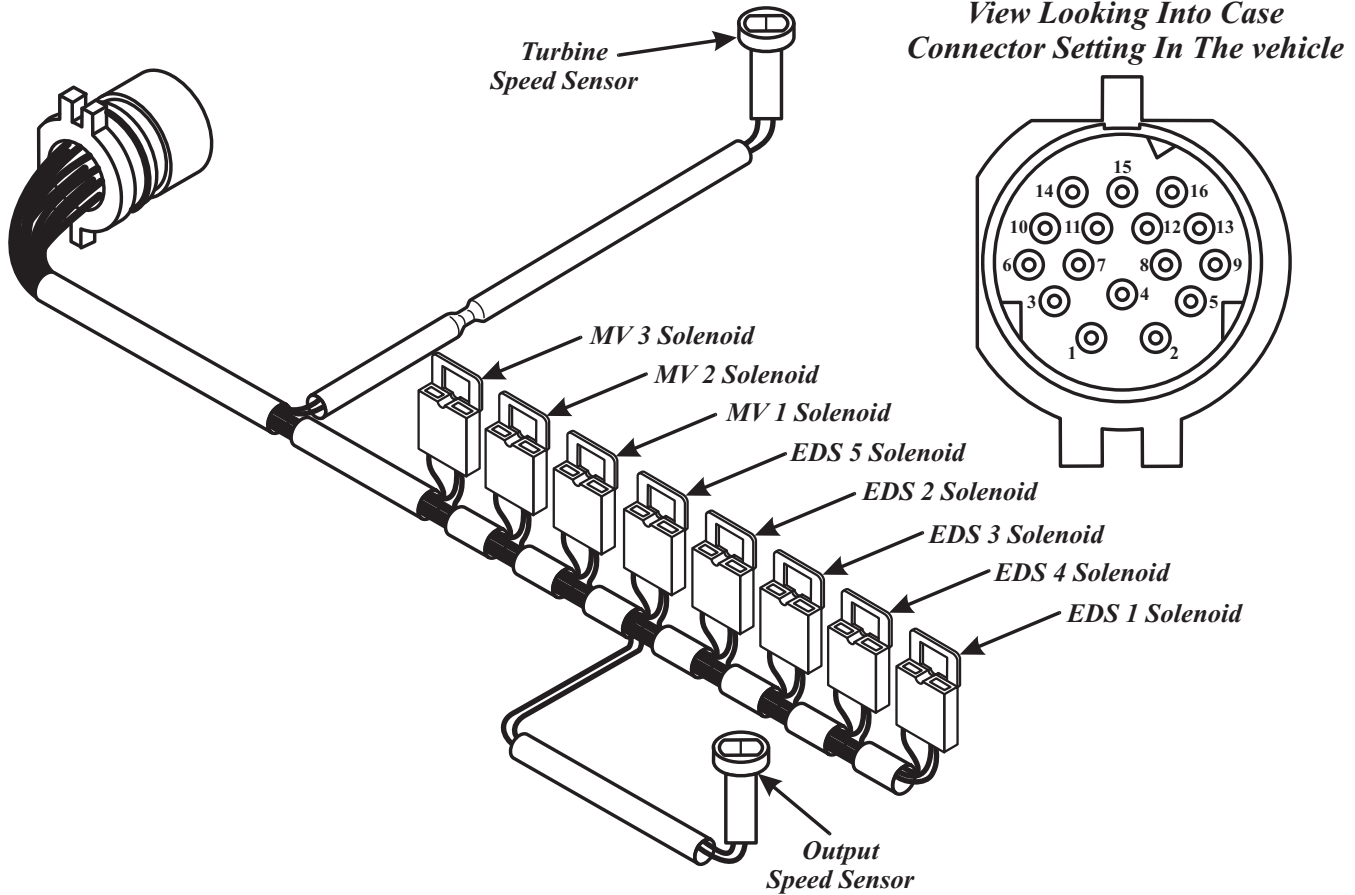

Figure 101

ZF-5HP-24 INTERNAL WIRE SCHEMATIC



NOTE: Some internal wire colors may vary.

Copyright © 2003 ATSG

Figure 102

ZF-5HP-24 SOLENOID APPLICATION CHART

<i>Selector Lever Position</i>	<i>MV 1 Solenoid</i>	<i>MV 2 Solenoid</i>	<i>MV 3 Solenoid</i>	<i>EDS 1 Solenoid</i>	<i>EDS 2 Solenoid</i>	<i>EDS 3 Solenoid</i>	<i>EDS 4 Solenoid</i>	<i>EDS 5 Solenoid</i>	GEAR RATIO
PARK	ON		ON	**	-*	*		-*	
REVERSE		ON	⊗	**	*-	*		*-	4.10:1
NEUTRAL	ON		ON	**	-*	*		-*	
D-1ST	ON			**	*-	*		*-	3.57:1
D-2ND	ON	ON		**		*		*	2.20:1
D-3RD		ON		**		*			1.51:1
D-4TH		ON		**			-*-		1.00:1
D-5TH				**			-*-		0.80:1
D-5TH "TCC"				**			*		0.80:1

SOLENOID CHART LEGEND

<i>Symbol</i>	<i>Description</i>
ON	<i>MV 1, MV 2 and MV 3 Solenoids are energized by the Electronic Transmission Control unit and have two functions. They are Open or Closed. Energized (On), there is pressure in circuit.</i>
⊗	<i>MV 3 is turned "ON" if reverse is selected at a high vehicle speed, to inhibit reverse engagement.</i>
**	<i>EDS 1 is used for line pressure control only, and operates from 0 to 0.8 amps. When the solenoid is "OFF" (0 amps), pressure is high. EDS 1 pressure is "Lowered" as the solenoid is modulated by the control unit.</i>
*	<i>EDS 2, EDS 3, EDS 4 and EDS 5 Solenoids are also pulse modulated but are exactly the opposite of EDS 1 Solenoid. When these solenoids are "ON" oil pressure in the hydraulic circuit is high, and when they are "OFF" pressure in the hydraulic circuit is low.</i>
-*	<i>Solenoid "OFF" (hydraulic pressure low), then Solenoid "ON" (hydraulic pressure high).</i>
*-	<i>Solenoid "ON" briefly (hydraulic pressure high), then Solenoid "OFF" (hydraulic pressure low). The pressure acts briefly on regulator valves to cushion clutch application.</i>
-*-	<i>EDS 4 Solenoid is used for Torque Converter Clutch apply and release only, and depends on throttle position and vehicle speed as to its application.</i>

Figure 103

EDS-5 SOLENOID OPERATION

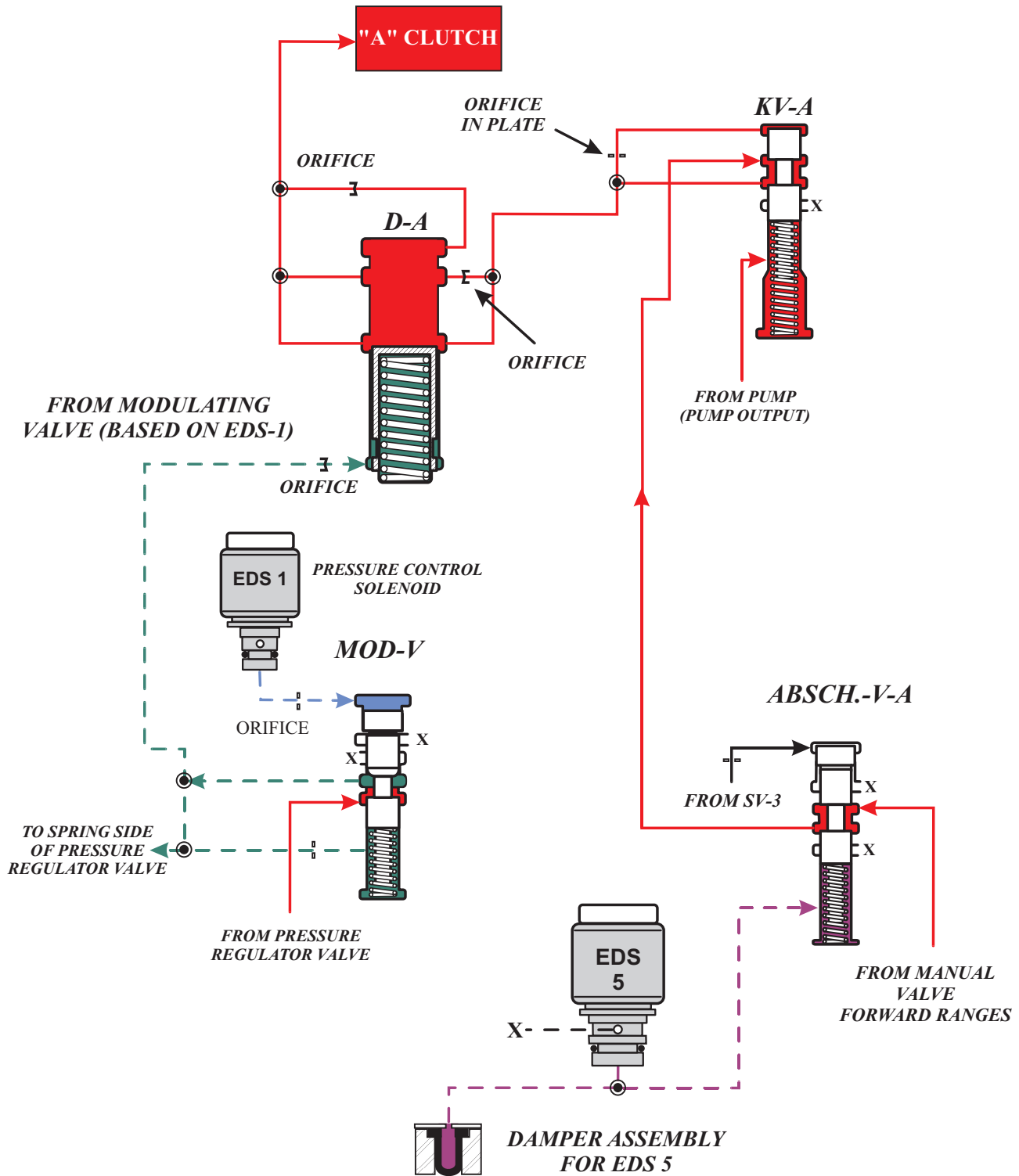

EDS 5 is used to prevent the ABSCH.-V-A, which is the switch valve for the A clutch, from stroking against its spring. Its use is mainly for forward engagement and a 5-4 downshift.

Figure 104

SOLENOID AND SENSOR RESISTANCE CHART

<i>Solenoid</i>	<i>Case Connector Pin Numbers - +</i>	<i>Resistance In Ohms</i>
MV 1	8 and 12	30 - 34 Ω
MV 2	9 and 12	30 - 34 Ω
MV 3	4 and 12	30 - 34 Ω
EDS 1	2 and 12	5.2 - 6.8 Ω
EDS 2	3 and 12	6.2 - 7.8 Ω
EDS 3	7 and 12	6.2 - 7.8 Ω
EDS 4	11 and 12	6.2 - 7.8 Ω
EDS 5	15 and 12	6.2 - 7.8 Ω
TOT	13 and 14	1000 Ω at 25° C
TSS	1 and 10	292 - 358 Ω
OSS	5 and 6	292 - 358 Ω

*View Looking Into Case
Connector Setting In The vehicle*

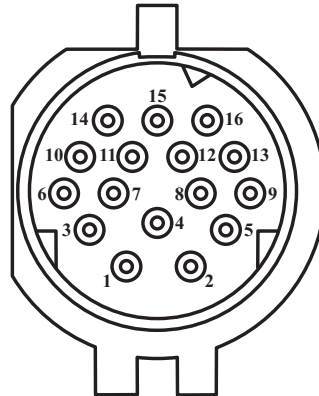

Electronic Control Unit Connector Pin Identification

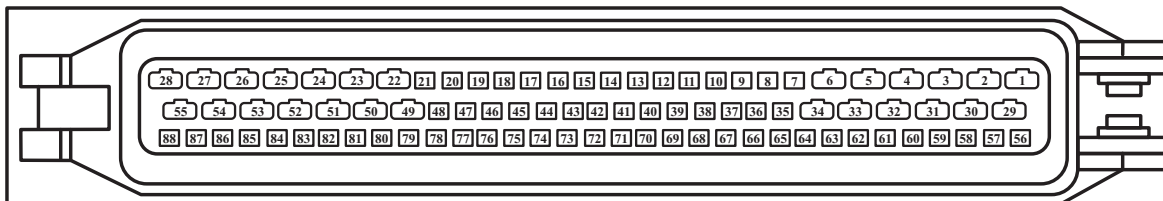
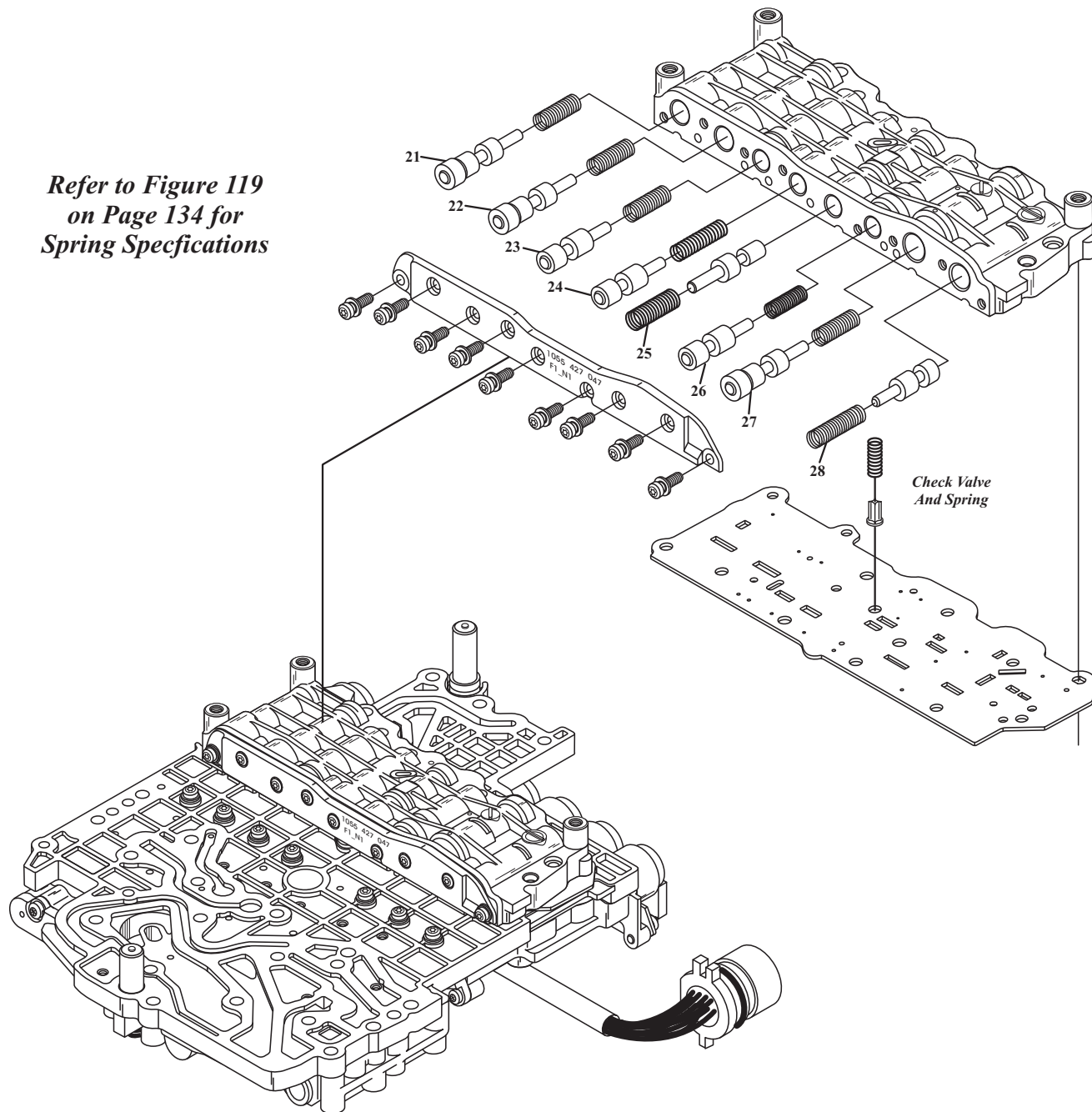

Figure 105

ZF-5HP-24 UPPER VALVE BODY

*Refer to Figure 119
on Page 134 for
Spring Specifications*



- 21. Clutch Valve "F" Line-Up (KV-F).
- 22. Clutch Valve "E" Line-Up KV-E).
- 23. Pressure Reducing Valve 1 (DR-V1).
- 24. Pressure Reducing Valve 2 (DR-V2).
- 25. Clutch Valve "B" Line-Up (KV-B).
- 26. Holding Valve "E" Line-Up (HV-E).
- 27. Switch Valve For "A" Clutch (ABSCH-V-A).

Copyright © 2003 ATSG

Figure 106

ZF-5HP-24 LOWER FRONT VALVE BODY

*Refer to Figure 119
on Page 134 for
Spring Specifications*

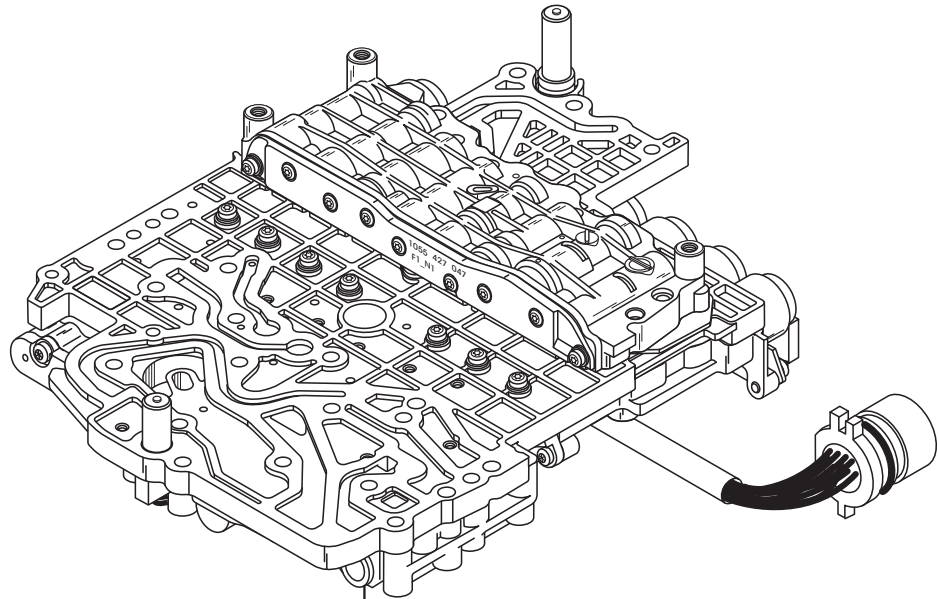

- 9. Manual Shift Valve (W-S).
- 10. Converter Clutch Apply Oil Control Valve (WK-V).
- 11. Converter Clutch Release Oil Control Valve (WD-V).
- 12. Main Pressure Regulator Valve Line-Up (HD-V).
- 13. Lubrication Valve (SCHM-V)
- 14. Modulating Valve Line-Up (MOD-V).
- 15. Holding Valve For "B" Clutch (HV-B).
- 16. Accumulator Valve For EDS 2 Solenoid (D-2).
- 17. Holding Valve For "D" Clutch (HV-D).
- 18. Accumulator Valve For EDS 4 Solenoid (D-4).
- 19. Accumulator Valve For EDS 3 Solenoid (D-3).

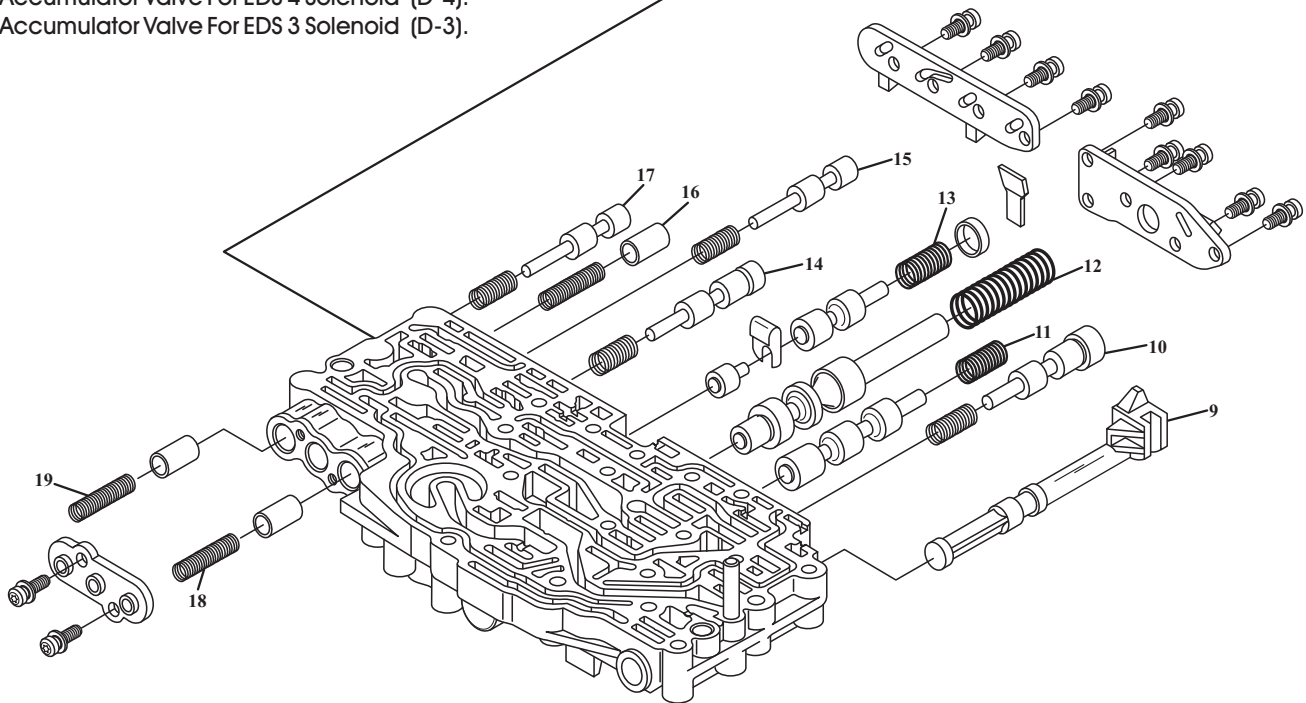

Copyright © 2003 ATSG

Figure 107

ZF-5HP-24 LOWER REAR VALVE BODY

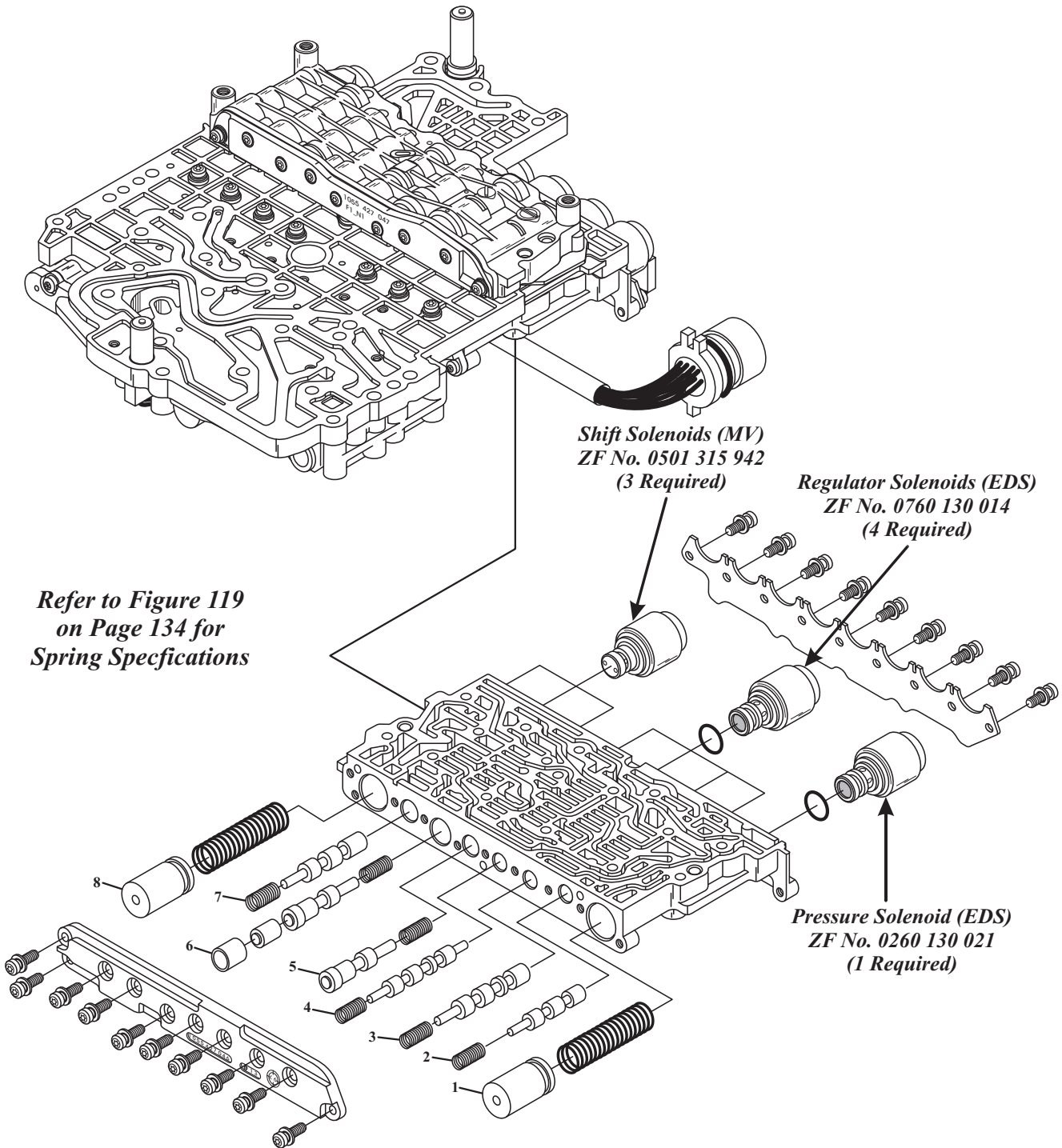

*Refer to Figure 119
on Page 134 for
Spring Specifications*

Shift Solenoids (MV)
ZF No. 0501 315 942
(3 Required)

Regulator Solenoids (EDS)
ZF No. 0760 130 014
(4 Required)

Pressure Solenoid (EDS)
ZF No. 0260 130 021
(1 Required)

1. "A" Clutch Accumulator Line-Up (D-A).
2. Shift Valve Number 1 (SV-1).
3. Shift Valve Number 2 (SV-2).
4. Shift Valve Number 3 (SV-3).
5. Switch Valve For "D" Clutch (ABSCH-V-D).
6. Clutch Valve "D" Line-Up (KV-D).
7. Reverse Gear Valve Line-Up (RG-V).

Copyright © 2003 ATSG

Figure 108

ZF 5HP-24 UPPER VALVE BODY

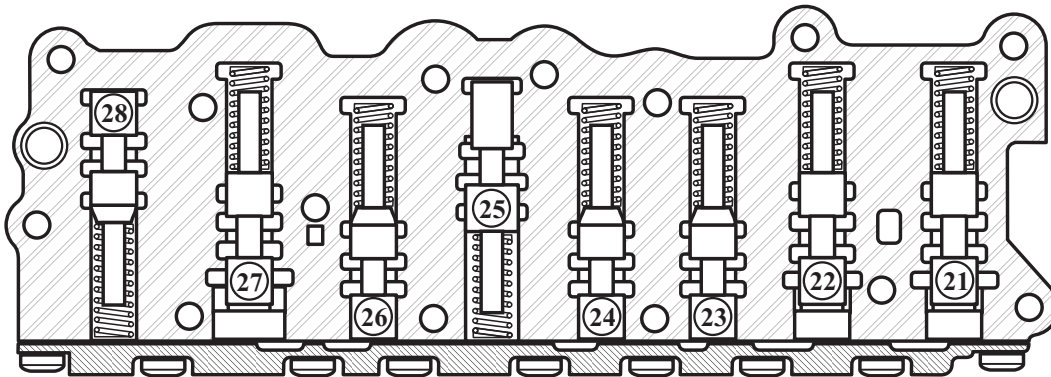

- 21. Clutch Valve "F" Line-Up (KV-F).
- 22. Clutch Valve "E" Line-Up (KV-E).
- 23. Pressure Reducing Valve 1 (DR-V1).
- 24. Pressure Reducing Valve 2 (DR-V2).
- 25. Clutch Valve "B" Line-Up (KV-B).
- 26. Holding Valve "E" Line-Up (HV-E).
- 27. Switch Valve For "A" Clutch (ABSCH-V-A).

*Refer to Figure 119
on Page 134 for
Spring Specifications*

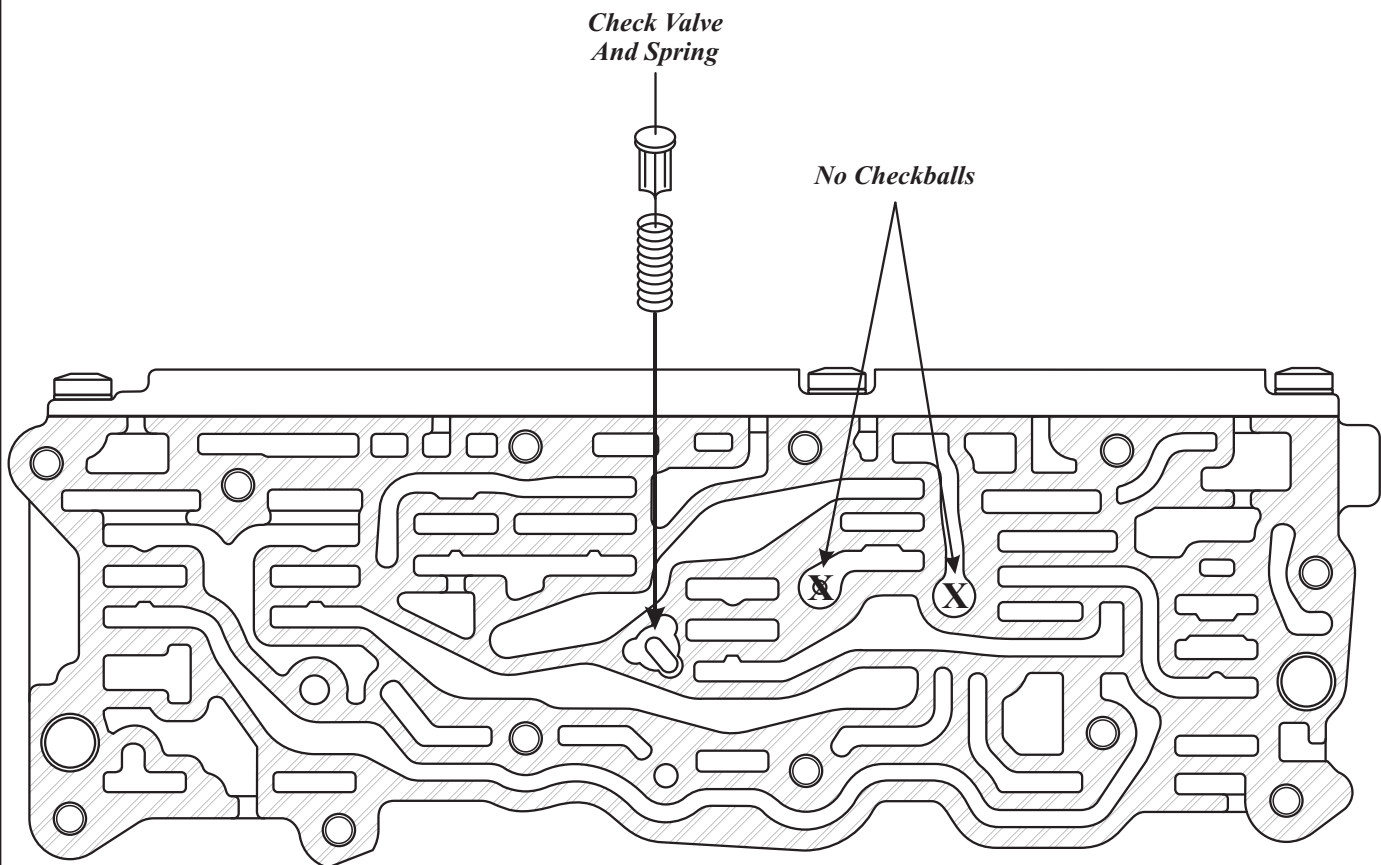

Figure 109

ZF 5HP-24 LOWER FRONT VALVE BODY

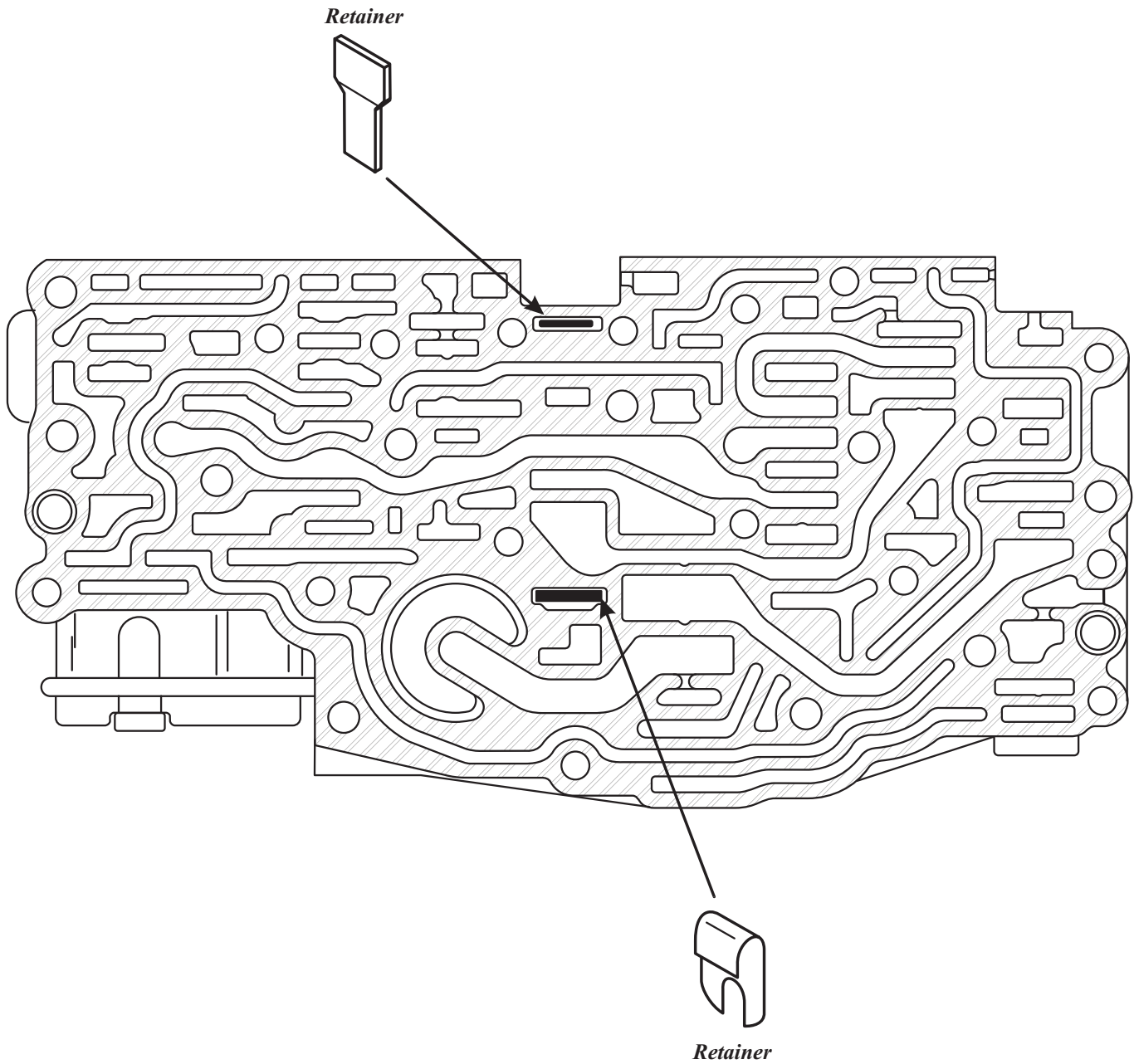

Figure 110

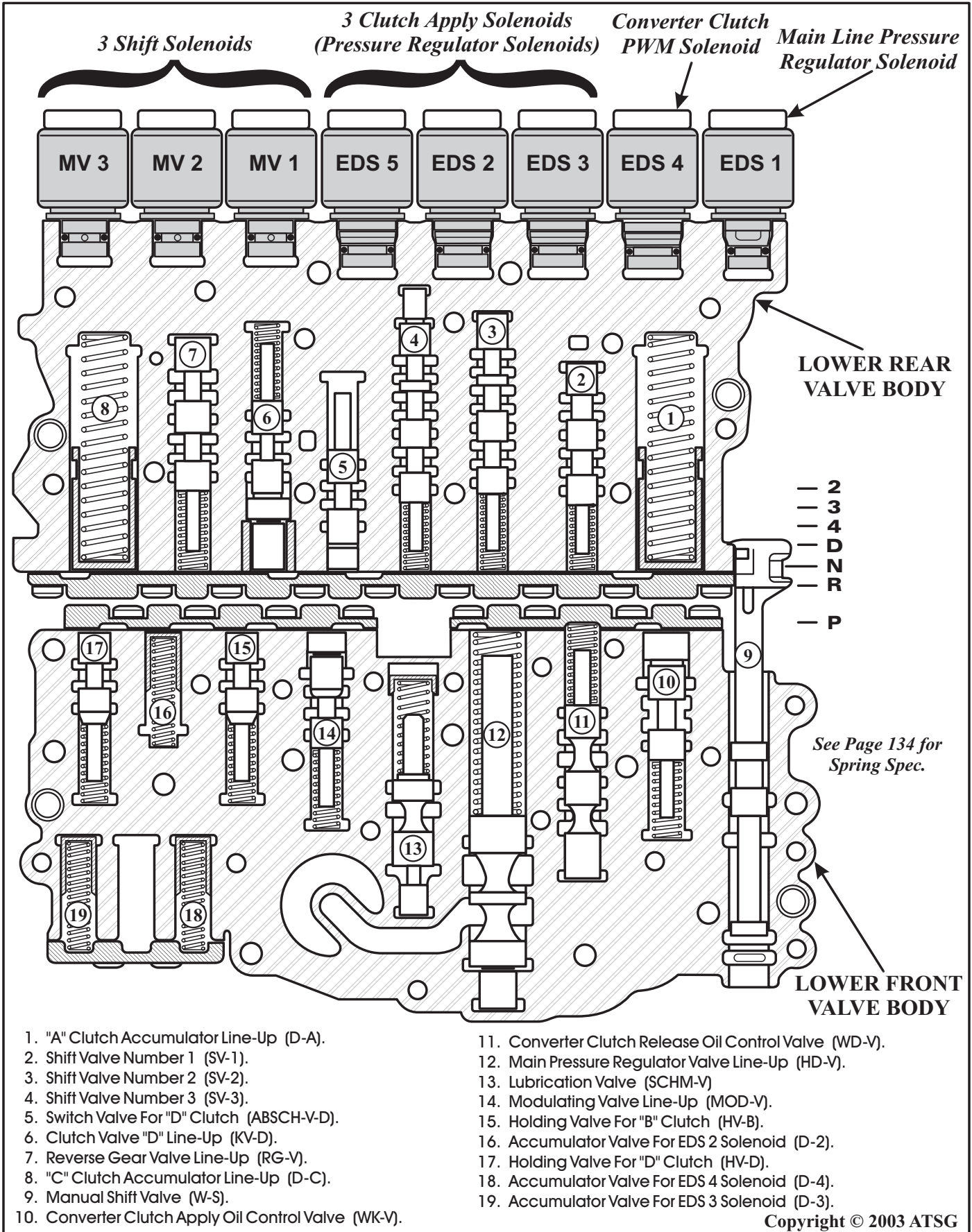

Figure 111

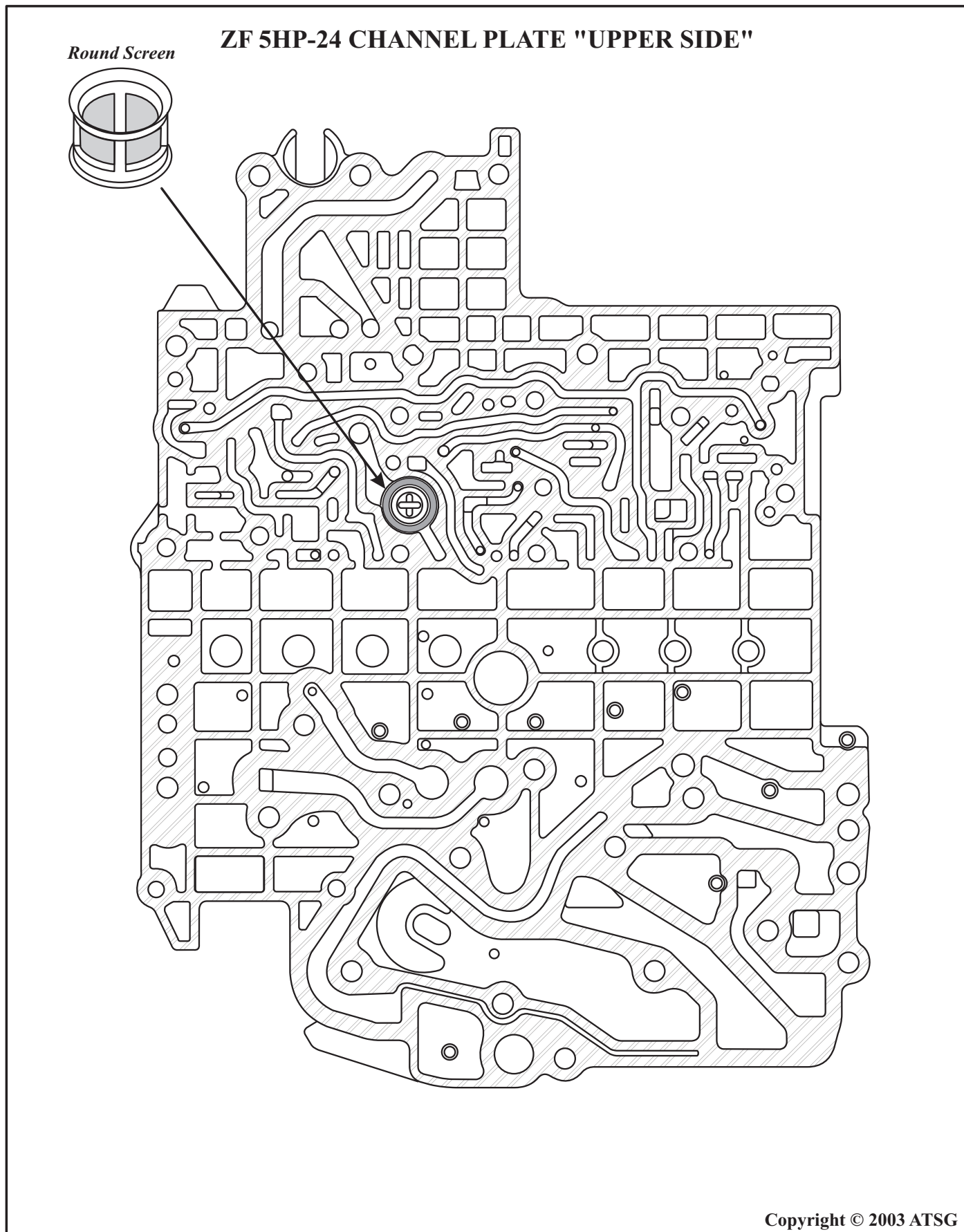
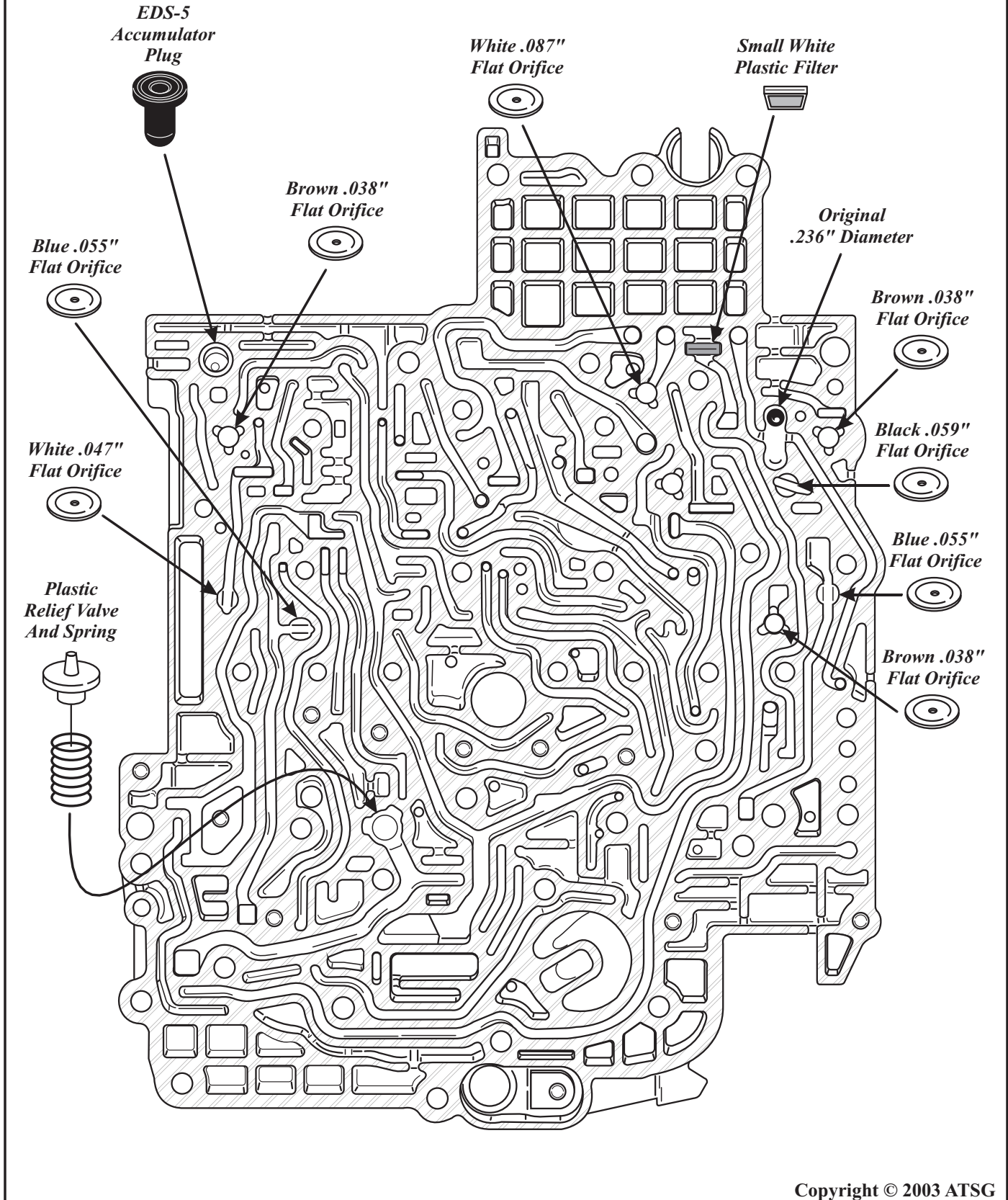

Figure 112

ZF 5HP-24 CHANNEL PLATE "LOWER SIDE"



Copyright © 2003 ATSG

Figure 113

PRESSURE TAP LOCATIONS AND IDENTIFICATION

Jaguar Model Shown

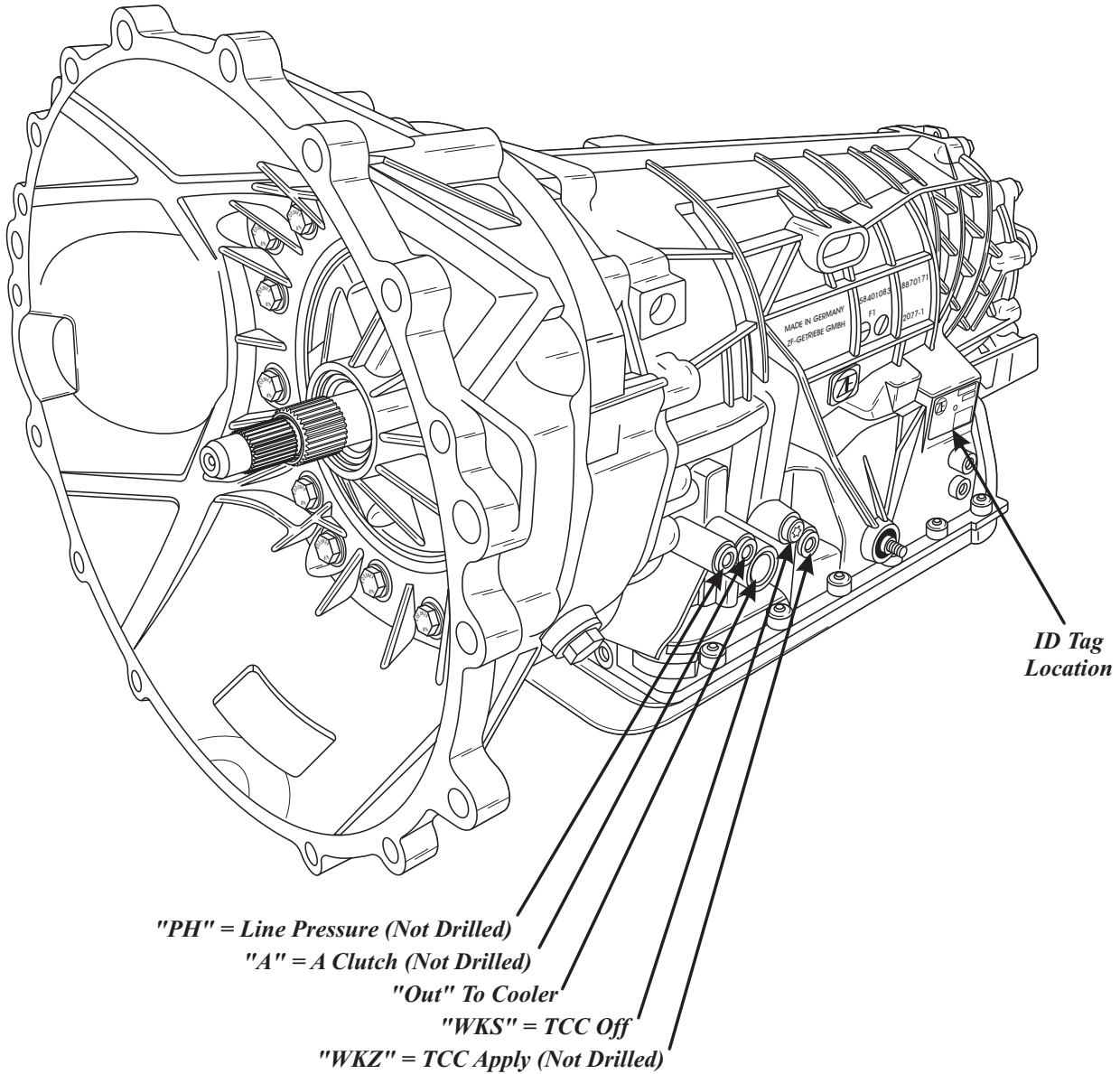
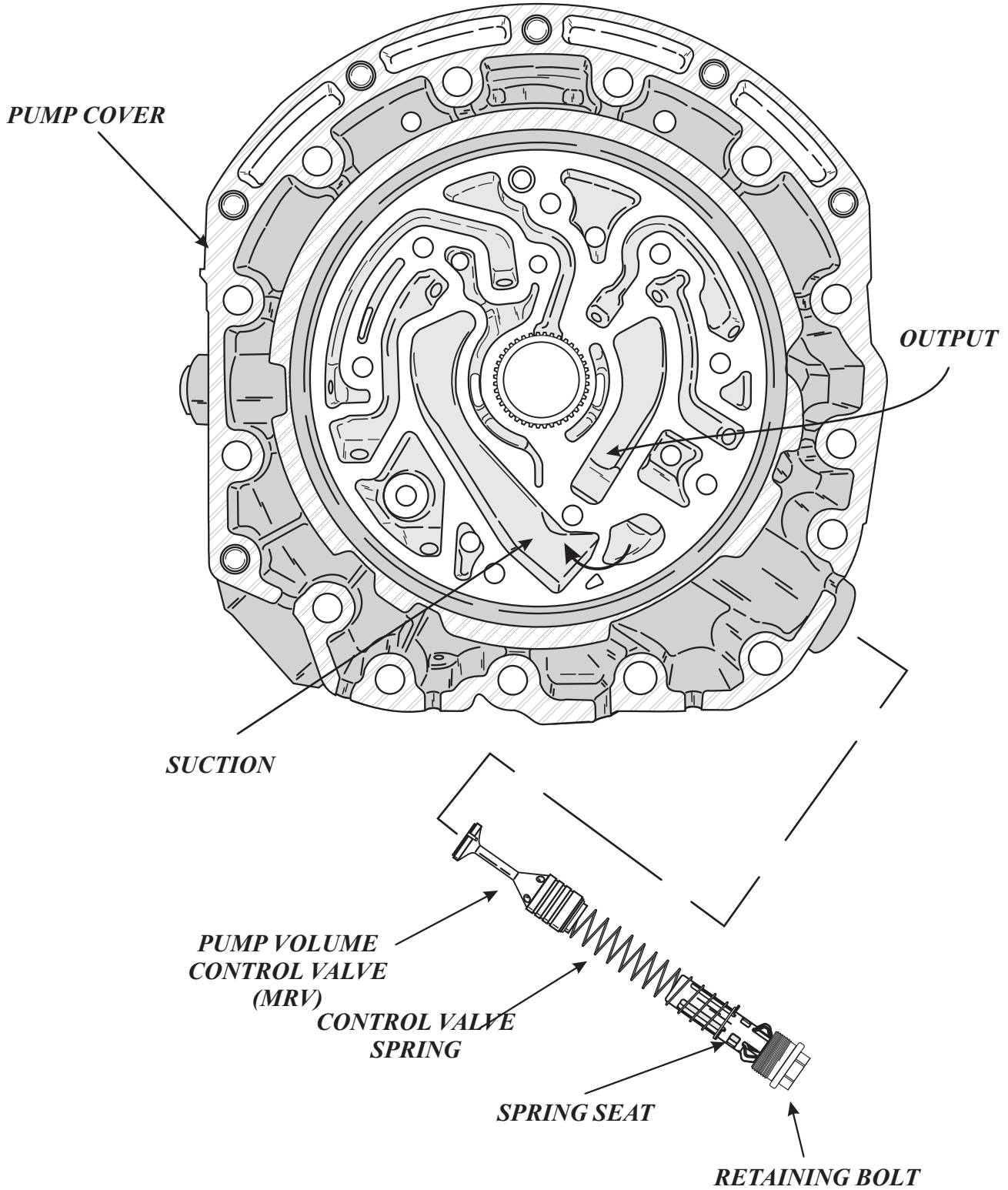

Figure 114

**PUMP VOLUME CONTROL
VALVE LOCATION**



Copyright © 2003 ATSG

Figure 115

**PUMP VOLUME CONTROL
VALVE OPERATION**

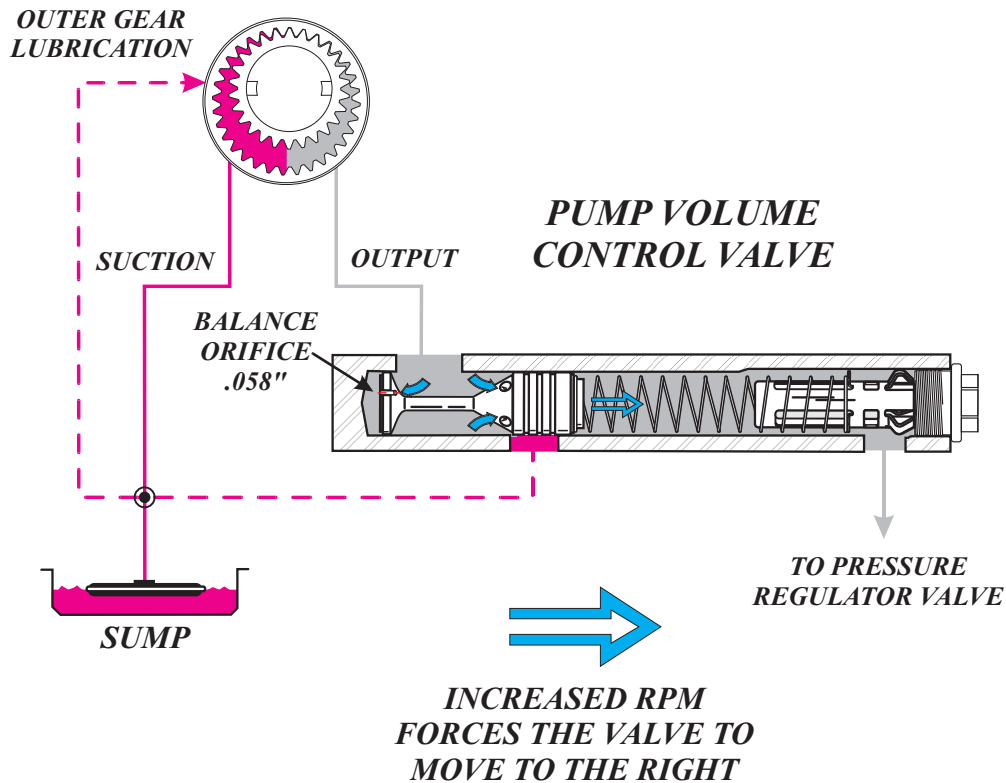

The Pump Volume Control Valve regulates the amount of oil volume to the Pressure Regulator Valve. As engine rpm. increases, pump output increases and forces the Pump Volume Control Valve to move to the right. This allows excess pump output to return to the sump, and a consistent amount of volume to be sent to the Pressure Regulator Valve. The Pump Control Valve maintains 45 to 48 gallons per minute from 2000 to 6000 rpm.

Figure 116

ZF 5HP-24 PUMP COVER REAR VIEW

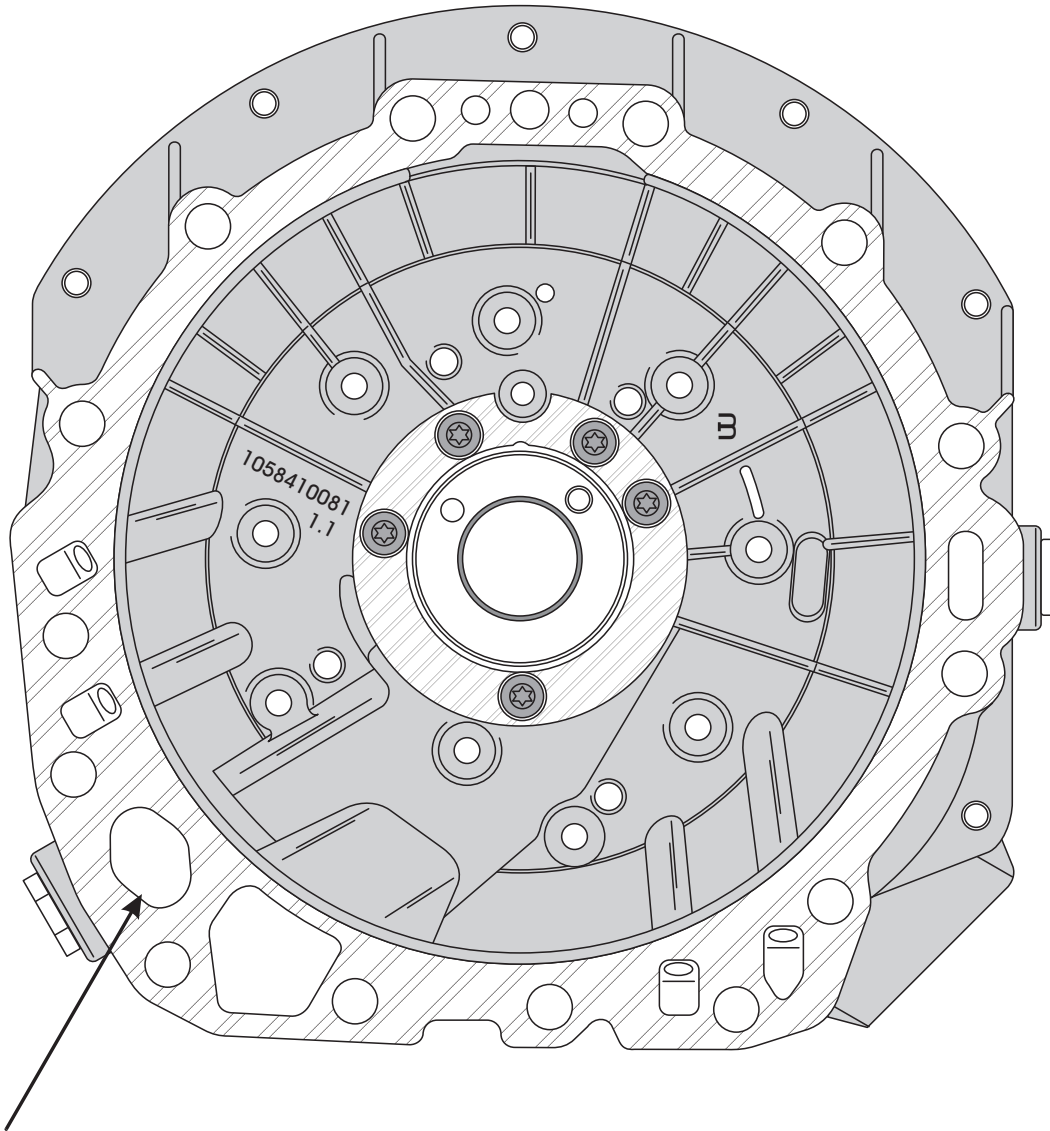

*Output to Pressure
Regulator Valve*

Figure 117

**PUMP AND
PUMP PLATE**

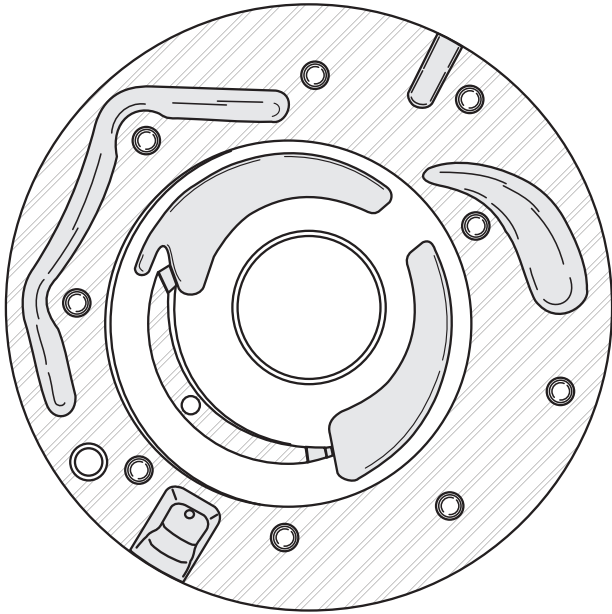

PUMP BODY

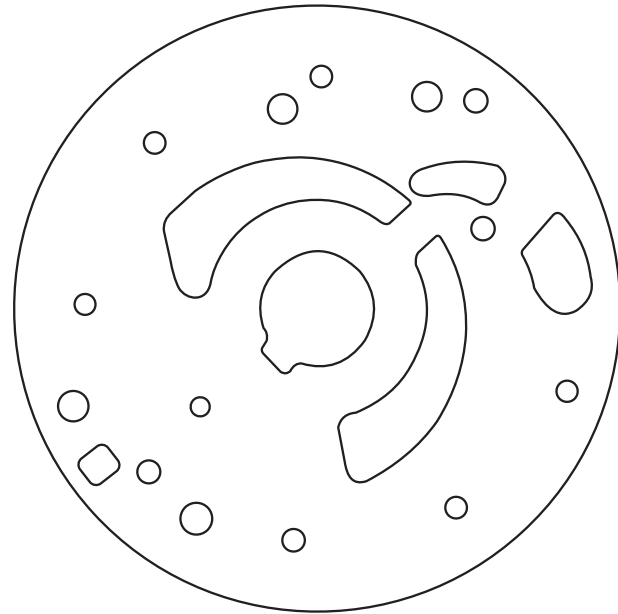

PUMP PLATE

**OUTER PUMP
GEAR LUBRICATION**

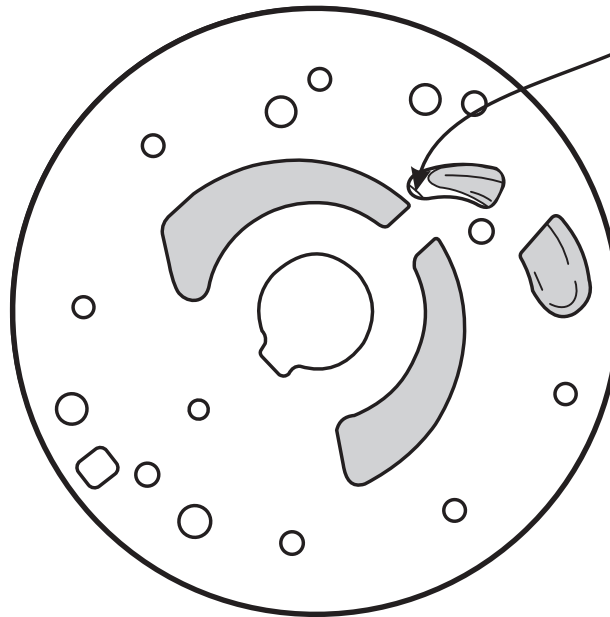

**PUMP PLATE INSTALLED
ON PUMP BODY**

Figure 118



TECHNICIANS DIAGNOSTIC GUIDE

BMW, AUDI, PORSCHE

ZF 5HP-24 VALVE BODY SPRING SPECIFICATIONS

UPPER VALVE BODY

- | | | |
|--|--|--|
| <p>21. Clutch Valve "F" (KV-F)
Free Length = 1.400"
Wire Diameter = .031"
Outside Diameter = .365"</p> | <p>24. Pressure Reducing Valve (DR-V2)
Free Length = 1.942"
Wire Diameter = .045"
Outside Diameter = .370"</p> | <p>27. A Clutch Swit Valve (ABSCH.V-A)
Free Length = 1.455"
Wire Diameter = .028"
Outside Diameter = .365"</p> |
| <p>22. Clutch Valve "E" (KV-E)
Free Length = 1.551"
Wire Diameter = .031"
Outside Diameter = .365"</p> | <p>25. Clutch Valve "B" (KV-B)
Free Length = 1.710"
Wire Diameter = .042"
Outside Diameter = .420"</p> | <p>28. Clutch Valve "A" (KV-A)
Free Length = 1.830"
Wire Diameter = .028"
Outside Diameter = .316"</p> |
| <p>23. Pressure Reducing Valve (DR-V1)
Free Length = 1.685"
Wire Diameter = .042"
Outside Diameter = .370"</p> | <p>26. Holding Valve "E" (KV-E)
Free Length = 1.685"
Wire Diameter = .042"
Outside Diameter = .372"</p> | <p><i>These spring locations
shown on Page 121.</i></p> |

LOWER "FRONT" VALVE BODY

- | | | |
|---|---|---|
| <p>10. TCC Apply Control Valve (WK-V)
Free Length = 1.952"
Wire Diameter = .042"
Outside Diameter = .370"</p> | <p>14. Modulating Valve (MOD-V)
Free Length = 1.493"
Wire Diameter = .031"
Outside Diameter = .365"</p> | <p>18. EDS 4, Accumulator Valve (D-4)
Free Length = 1.560"
Wire Diameter = .042"
Outside Diameter = .322"</p> |
| <p>11. TCC Release Control Valve (WD-V)
Free Length = 2.052"
Wire Diameter = .034"
Outside Diameter = .438"</p> | <p>15. Holding Valve, "B" Clutch (HV-B)
Free Length = 1.414"
Wire Diameter = .031"
Outside Diameter = .365"</p> | <p>19. EDS 3, Accumulator Valve (D-3)
Free Length = 1.560"
Wire Diameter = .042"
Outside Diameter = .322"</p> |
| <p>12. Pressure Regulator Valve (HD-V)
Free Length = 3.780"
Wire Diameter = .087"
Outside Diameter = .686"</p> | <p>16. EDS 2, Accumulator Valve (D-2)
Free Length = 1.565"
Wire Diameter = .042"
Outside Diameter = .322"</p> | <p><i>These spring locations
shown on Page 122.</i></p> |
| <p>13. Lubrication Valve (SCHM.-V)
Free Length = 1.710"
Wire Diameter = .048"
Outside Diameter = .485"</p> | <p>17. Holding Valve, "D" Clutch (HV-B)
Free Length = 1.681"
Wire Diameter = .042"
Outside Diameter = .375"</p> | |

LOWER REAR VALVE BODY

- | | | |
|--|---|--|
| <p>1. "A" Clutch Accumulator (D-A)
Free Length = 3.067"
Wire Diameter = .066"
Outside Diameter = .595"</p> | <p>4. Shift Valve Number 3 (SV-3)
Free Length = 1.640"
Wire Diameter = .031"
Outside Diameter = .366"</p> | <p>7. Reverse Gear Valve (RG-V)
Free Length = 1.800"
Wire Diameter = .038"
Outside Diameter = .435"</p> |
| <p>2. Shift Valve Number 1 (SV-1)
Free Length = 1.755"
Wire Diameter = .031"
Outside Diameter = .367"</p> | <p>5. Switch Valve "D" Clutch (ABSCH.V-D)
Free Length = 1.396"
Wire Diameter = .039"
Outside Diameter = .300"</p> | <p>8. "C" Clutch Accumulator (D-C)
Free Length = 3.067"
Wire Diameter = .066"
Outside Diameter = .595"</p> |
| <p>3. Shift Valve Number 2 (SV-2)
Free Length = 1.770"
Wire Diameter = .031"
Outside Diameter = .367"</p> | <p>6. Clutch Valve "D" Line-Up (KV-D)
Free Length = 1.800"
Wire Diameter = .031"
Outside Diameter = .360"</p> | <p><i>These spring locations
shown on Page 123.</i></p> |

Copyright © 2003 ATSG

Figure 119

**BMW ZF-5HP-30
DIAGNOSTIC INFORMATION**

840cia E31	92-96
740ia & 740il E38	94-97
750il & 850cia E31 & e38	94-Current
540ia E34, 740ia, & 740il E32	91-95

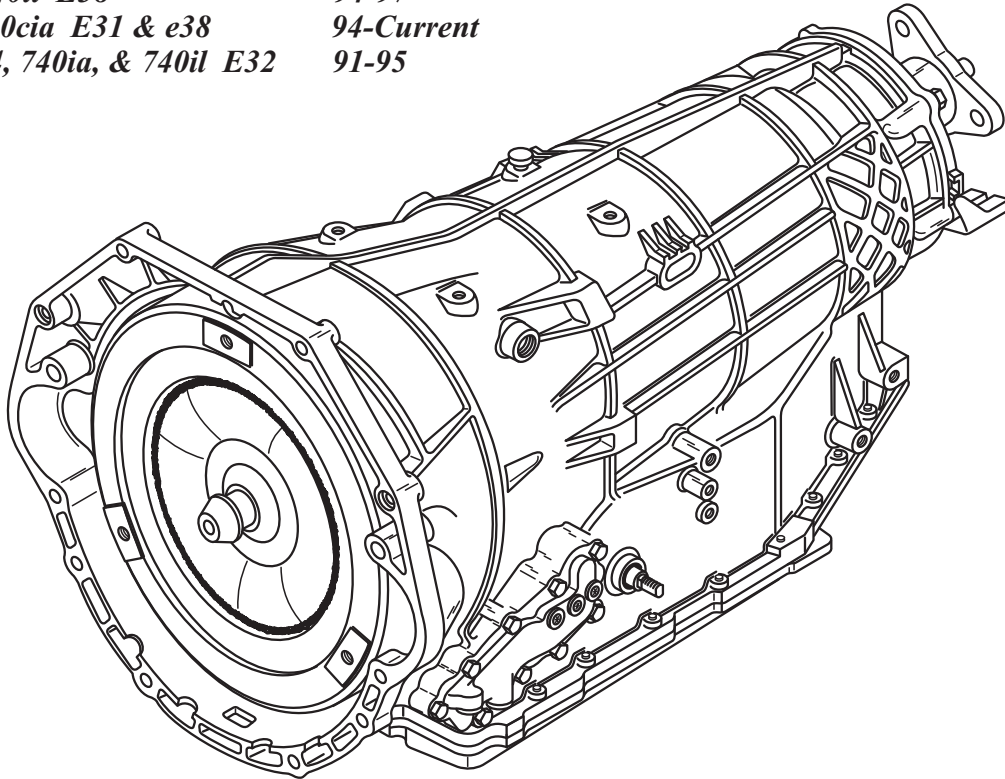

This transmission is manufactured in Germany by ZF and carries the BMW designation A5S 560Z.

The A5S 560Z is an electronically controlled, five speed automatic transmission with a lock-up clutch type torque converter. Three planetary gear sets (Wilson Gearing), three rotating multiple disc clutches, four multiple disc brake clutches, and two sprag clutches (Freewheels) are used to provide the five forward speeds and reverse.

Key to designation:

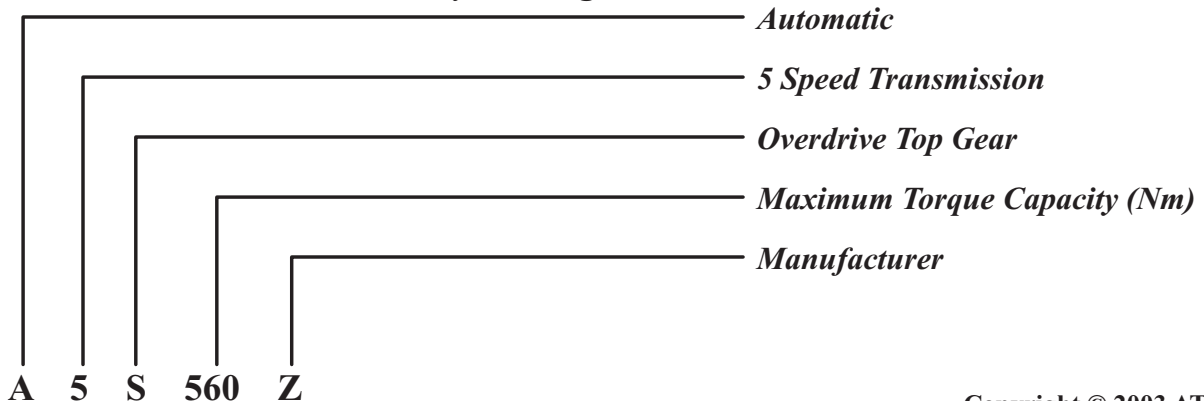

Copyright © 2003 ATSG

Figure 120



TECHNICIANS DIAGNOSTIC GUIDE

BMW, AUDI, PORSCHE

Refer to Figure 121 for Internal Component Application Chart.

Refer to Figure 122 for Normal Operation, Adaptive Shift Control, and Failsafe Operation.

Refer to Figures 123, 124, and 125 for Solenoid identification and locations, and both MV Solenoid Operation and EDS Solenoid Operation and tests.

Refer to Figure 126 for wiring harness identification, internal wiring schematic, and transmission case connector pin identification.

Refer to Figure 127 for individual Solenoid Application Chart and definitions.

Refer to Figure 128 for internal components resistance chart, with the pins identified for both the transmission case connector and the Electronic Control Unit.

Refer to Figure 129 and 130 for Retrieving Fault Codes, a Fault Code Chart with code definitions and the Diagnostic Tool required.

Refer to Figure 131 for all pressure tap locations.

Refer to Figure 132 for Upper Rear Valve Body exploded view and identification of valves.

Refer to Figure 133 for Lower Front Valve Body exploded view and identification of valves.

Refer to Figure 134 for Lower Rear Valve Body explode view and identification of valves.

Refer to Figures 135 and 136 for cut-away views and check ball locations in uppre rear valve body.

Refer to Figure 137 for all valve body spring specifications, as observed in a used valve body.

Refer to Figures 138 and 139 for the locations of the orifices, checkballs, screens and the check valves and springs that are located in the channel plate.

Refer to Page 156 for a condition of "No Reverse".

BMW ZF-5HP-30

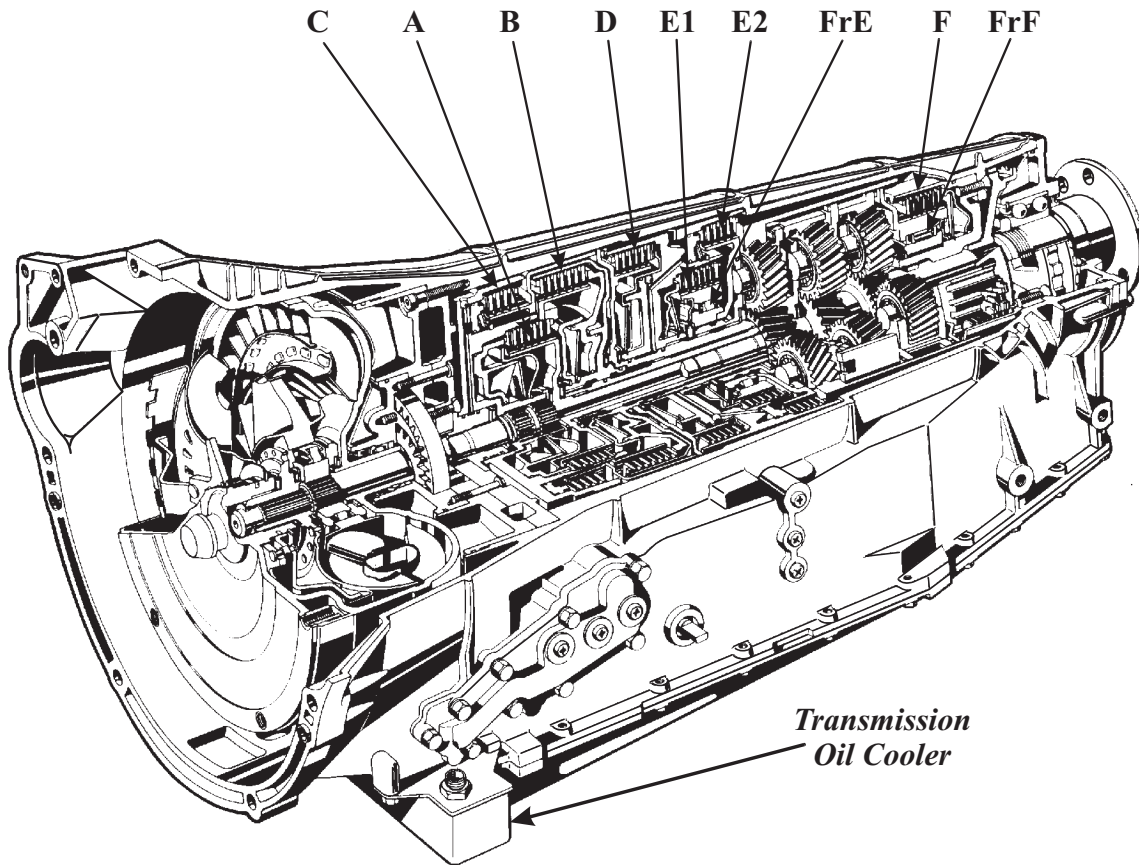

The oil cooler is a separate unit mounted on the underside of the transmission just ahead of the oil pan. The connections to the transmission oil supply are integrated into the mounting. The two external fittings visible are the supply and return lines for engine coolant. Full flow is maintained through the cooler at all times.

GEAR	"A" CLUT	"B" CLUT	"C" CLUT	"D" CLUT	"E1" CLUT	"E2" CLUT	"F" CLUT	"FrE" SPRAG	"FrF" SPRAG	GEAR RATIO
PARK							ON			
REV			ON	ON			ON			3.68:1
NEUT							ON			
D-1ST	ON								HOLD	3.55:1
D-2ND	ON				ON	ON		HOLD		2.24:1
D-3RD	ON			ON	ON					1.54:1
D-4TH	ON	ON			ON					1.00:1
D-5TH		ON		ON	ON					0.79:1
M-2	ON						ON			

Figure 121

NORMAL OPERATION:

A console mounted tip switch allows the driver to select either the Automatic or Winter mode. The Winter mode is designated by an ice crystal symbol () on the program switch. When in the Winter mode, the transmission starts off in 2nd gear and the upshifts are programmed to occur earlier to reduce the torque at the drive wheels and prevent wheel spin. The following chart explains the gear selection and each program mode based on the selector lever position.

SELECTOR LEVER POSITION	PROGRAM MODE	
	AUTOMATIC (A)	WINTER (*)
P	P	P
R	R	R
N	N	N
D	<i>D - Economy Program</i>	<i>D - Starts In 2nd, Early Upshifts 2-5</i>
4	<i>4 - Sport Program Delayed Upshifts 1-4</i>	<i>4 - Starts In 2nd, Early Upshifts 2-4</i>
3	<i>3 - Sport Program Delayed Upshifts 1-3</i>	<i>3 - Starts In 2nd, Early Upshifts 2-3</i>
2	<i>2 - Sport Program Delayed Upshifts 1-2</i>	<i>2 - Locked In 2nd</i>

ADAPTIVE SHIFT CONTROL:

Stop and Go Function:

When the transmission control module detects that the vehicle is being driven in a heavy traffic situation with many stops and starts at very low road speed, it will begin using 2nd gear when pulling away. Starting in 2nd gear and not downshifting to 1st gear when stopping eliminates the feeling of excessive load reversals, and provides a more comfortable driving style in this situation.

Deceleration Rate:

Typically, automatic transmission software programs will upshift to the highest gear possible when driven at a given road speed with no throttle application. The transmission control module on the A5S 560Z monitors the rate of change in throttle position when the throttle is released. If the throttle is released quickly, the transmission will stay in the present gear engaged, in anticipation of the drivers intent to slow down. If the throttle is gradually released, as when approaching desired road speed, the transmission will upshift to the next highest possible gear for that road speed.

FAILSAFE OPERATION:

When a system fault is detected which would impair normal reliable operation, the transmission control module interrupts the power supply to Pin 12 at the transmission case connector. The transmission control module also alerts the driver of any faults by signaling the vehicle's "check control" system. To enable the vehicle to be driven to a repair shop, the following manual gear selections are permitted:

<i>Selector Lever Position</i>	P R N D 4 3 2
<i>Actual Gear Obtained</i>	P R N 4 4 4 4

Figure 122

ZF 5HP-30
SOLENOID LOCATIONS AND IDENTIFICATION

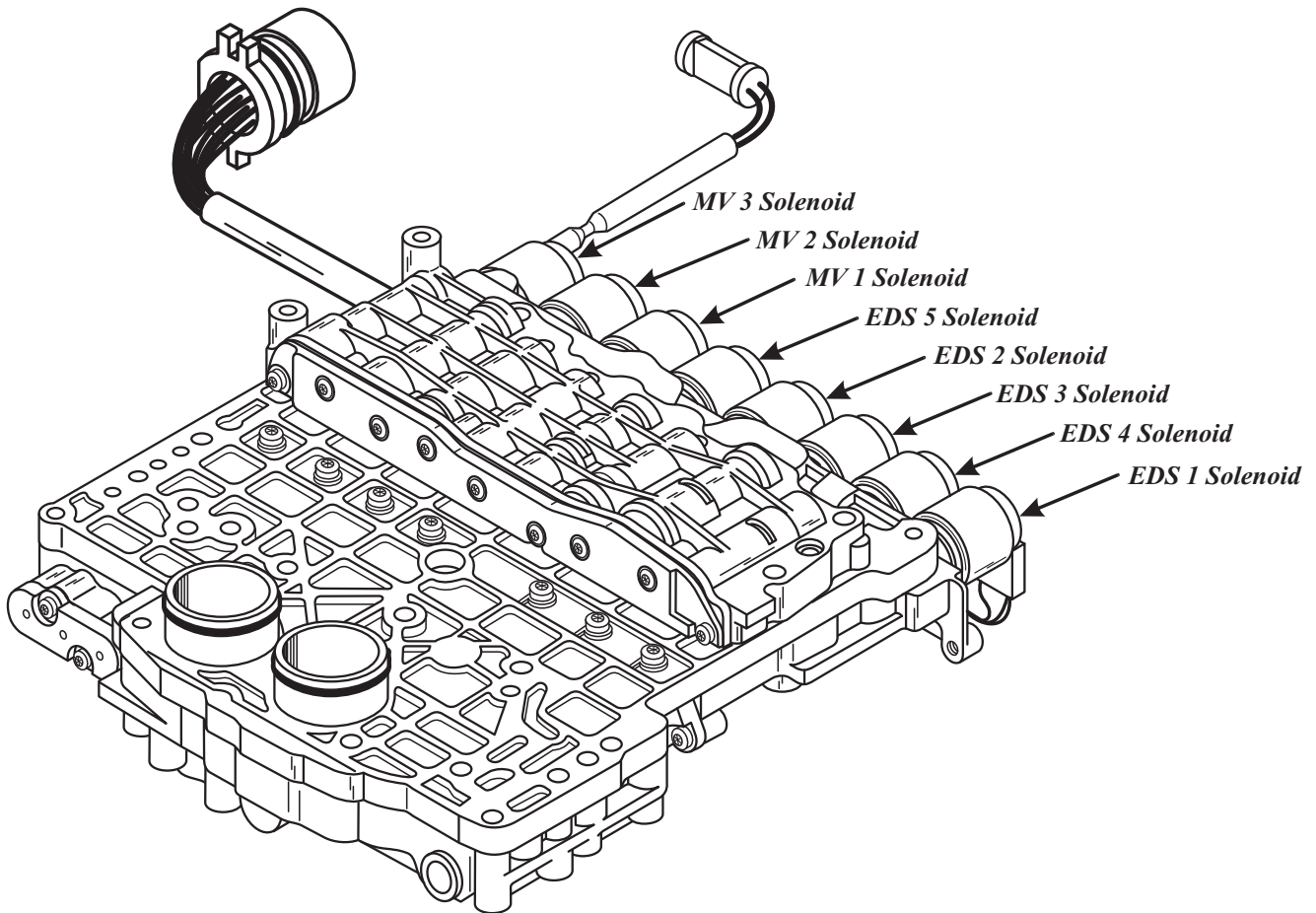
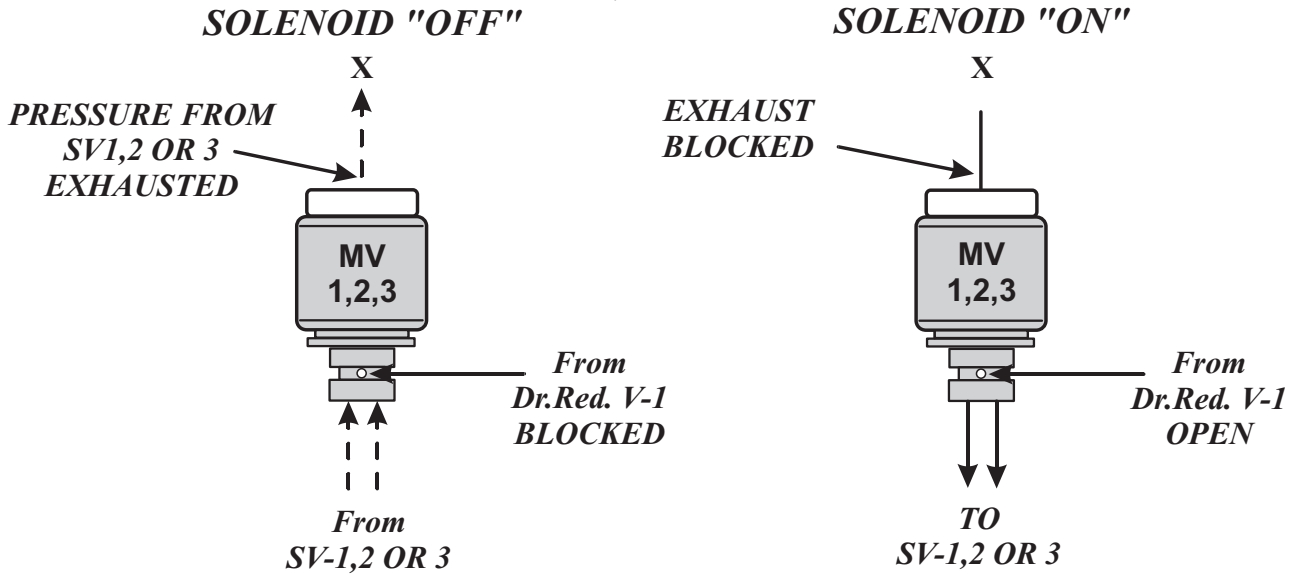

Figure 123

MV1, 2 AND 3



SUMMARY:

When MV 1, 2 or 3 is "OFF" Solenoid reducing pressure, from Dr.Red. V-1, is blocked by the solenoid and oil pressure from SV 1, 2 or 3 is exhausted at the rear of the solenoid.
 When MV 1, 2 or 3 is "ON" Solenoid reducing pressure, From Dr.Red. V-1, is open through the solenoid and is applied to SV 1, 2 or 3. The exhaust at the rear of the solenoid is closed.

EDS 2 -5

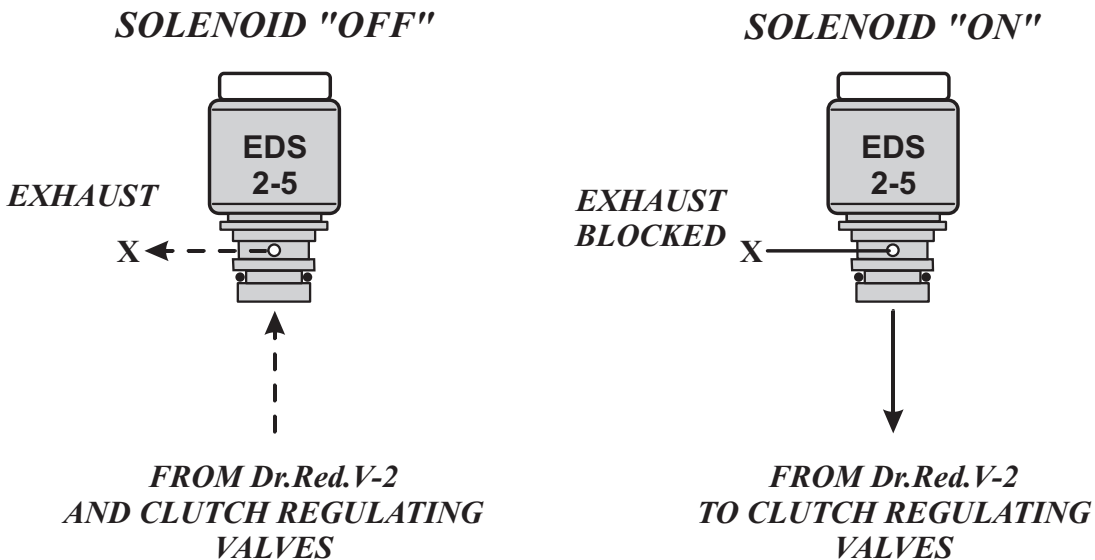

SUMMARY:

When EDS 2-5 solenoids are "OFF" they exhaust orificed solenoid reducing pressure, from Dr. Red. V-2, and the oil pressure from the clutch regulating valves releasing them.
 When EDS 2-5 solenoids are "ON" the exhaust is blocked by the solenoid and solenoid reducing pressure, from Dr. Red. V-2, is applied to operate clutch regulating valves.

Figure 124

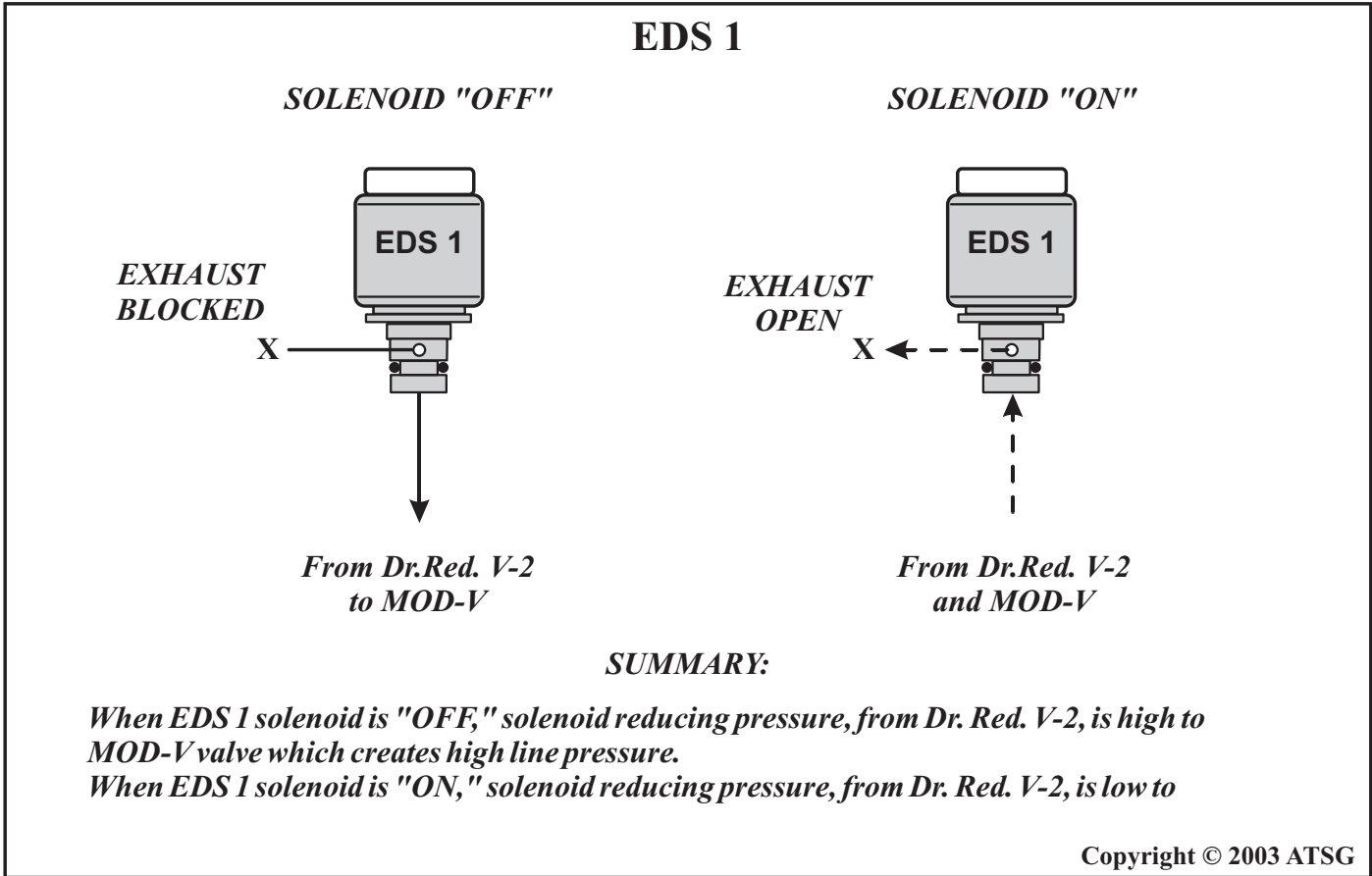
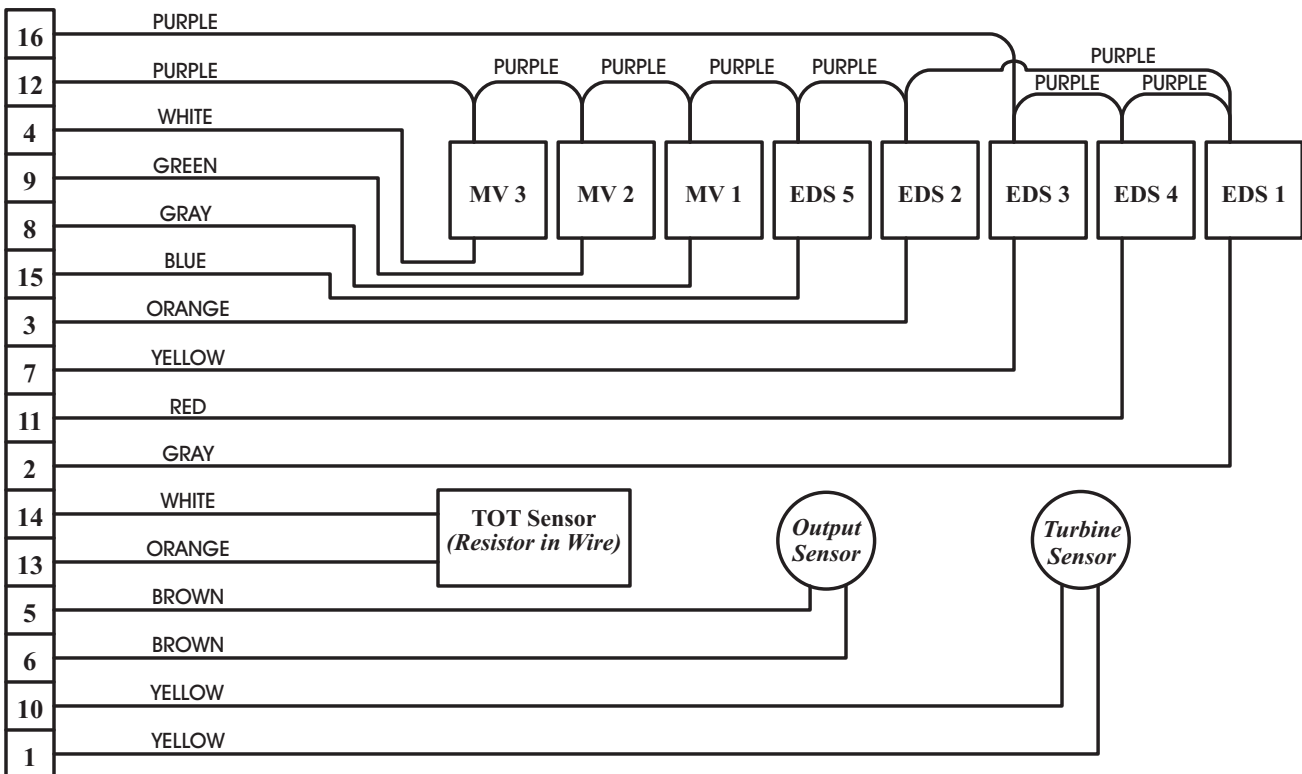
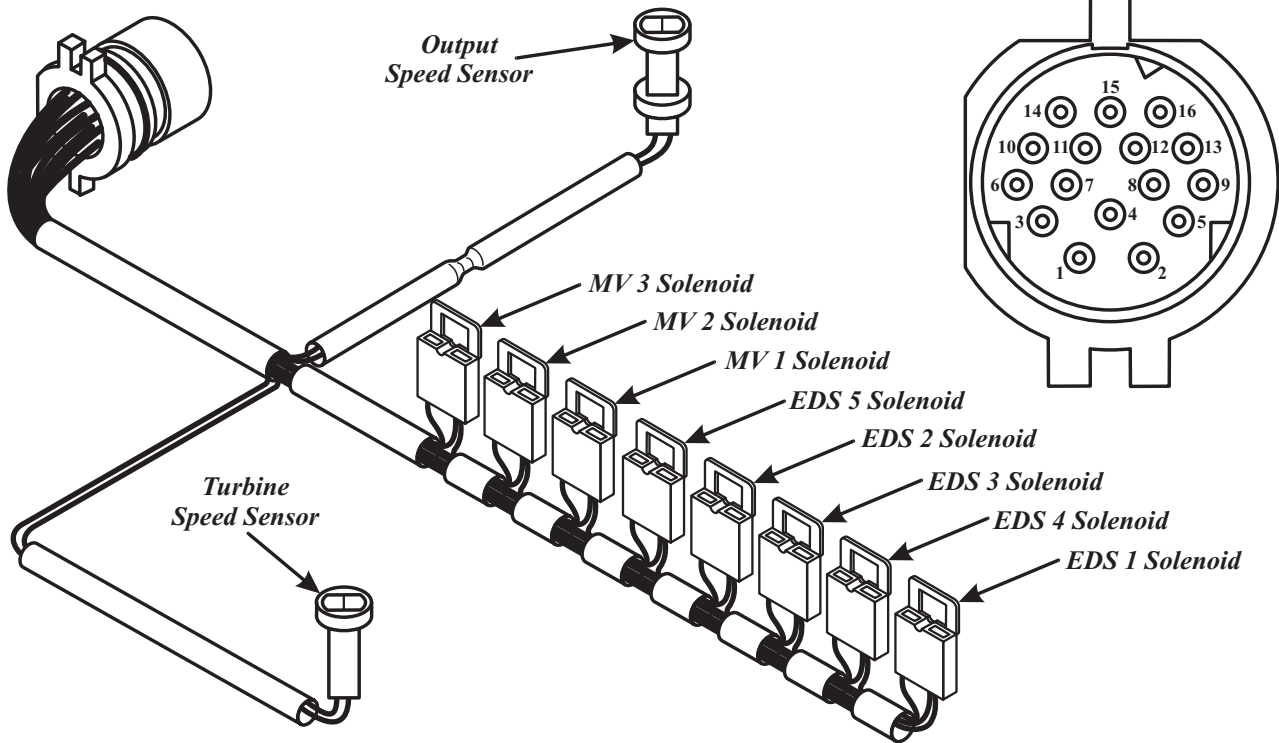

Figure 125

ZF-5HP-30 INTERNAL WIRE SCHEMATIC

*View Looking Into Case
Connector Setting In The vehicle*



NOTE: Some internal wire colors may vary.

Copyright © 2001 ATSG

Figure 126

TECHNICIANS DIAGNOSTIC GUIDE BMW, AUDI, PORSCHE

ZF-5HP-30 SOLENOID APPLICATION CHART

<i>Selector Lever Position</i>	<i>MV 1 Solenoid</i>	<i>MV 2 Solenoid</i>	<i>MV 3 Solenoid</i>	<i>EDS 1 Solenoid</i>	<i>EDS 2 Solenoid</i>	<i>EDS 3 Solenoid</i>	<i>EDS 4 Solenoid</i>	<i>EDS 5 Solenoid</i>	<i>GEAR RATIO</i>
PARK	ON			**					
REVERSE		ON	⊗	**	*-	*		*-	3.68:1
NEUTRAL	ON			**					
D-1ST	ON			**	*-	*-		*-	3.55:1
D-2ND	ON	ON		**		*		*	2.24:1
D-3RD		ON		**	*	*		*	1.54:1
D-4TH		ON		**	*-		-*-	*-	1.00:1
D-5TH			-*	**	*		-*-	*-	0.79:1
Failsafe (4th)	OFF	OFF	OFF	OFF	OFF	OFF	OFF	OFF	1.00:1

SOLENOID CHART LEGEND

<i>Symbol</i>	<i>Description</i>
ON	<i>MV 1, MV 2 and MV 3 Solenoids are energized by the Electronic Transmission Control unit and have two functions. They are Open or Closed. Energized (On), there is pressure in circuit.</i>
⊗	<i>MV 3 is turned "ON" if reverse is selected at a high vehicle speed, to inhibit reverse engagement.</i>
**	<i>EDS 1 is used for line pressure control only, and operates from 0 to 0.8 amps. When the solenoid is "OFF" (0 amps), pressure is high. EDS 1 pressure is "Lowered" as the solenoid is modulated by the</i>
*	<i>EDS 2, EDS 3, EDS 4 and EDS 5 Solenoids are also pulse modulated but are exactly the opposite of EDS 1 Solenoid. When these solenoids are "ON" oil pressure in the hydraulic circuit is high, and when they are "OFF" pressure in the hydraulic circuit is low.</i>
-*	<i>Solenoid "OFF" (hydraulic pressure low), then Solenoid "ON" (hydraulic pressure high).</i>
*-	<i>Solenoid "ON" briefly (hydraulic pressure high), then Solenoid "OFF" (hydraulic pressure low). The pressure acts briefly on regulator valves to cushion clutch application.</i>
-*-	<i>EDS 4 Solenoid is used for Torque Converter Clutch apply and release only, and depends on throttle position and vehicle speed as to its application.</i>

Figure 127

TECHNICIANS DIAGNOSTIC GUIDE

BMW, AUDI, PORSCHE

SOLENOID AND SENSOR RESISTANCE CHART

Solenoid	Case Connector Pin Numbers		Control Unit Connector Pin Numbers		Resistance In Ohms
	-	+	-	+	
MV 1	8	12	30	52	30 - 34 Ω
MV 2	9	12	33	52	30 - 34 Ω
MV 3	4	12	32	52	30 - 34 Ω
EDS 1	2	12	5	52	5.2 - 6.8 Ω
EDS 2	3	12	1	52	6.2 - 7.8 Ω
EDS 3	7	12	29	52	6.2 - 7.8 Ω
EDS 4	11	12	4	52	6.2 - 7.8 Ω
EDS 5	15	12	51	52	6.2 - 7.8 Ω
TOT	13	14	21	22	1000 Ω at 25° C
TSS	1	10	44	16	292 - 358 Ω
OSS	5	6	14	42	292 - 358 Ω

*View Looking Into Case
Connector Setting In The vehicle*

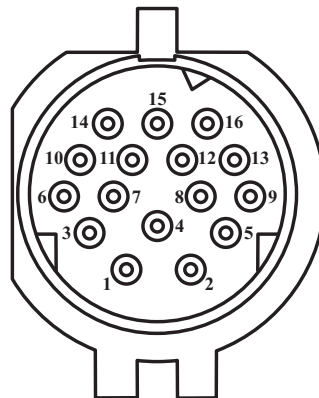

Electronic Control Unit Connector Pin Identification

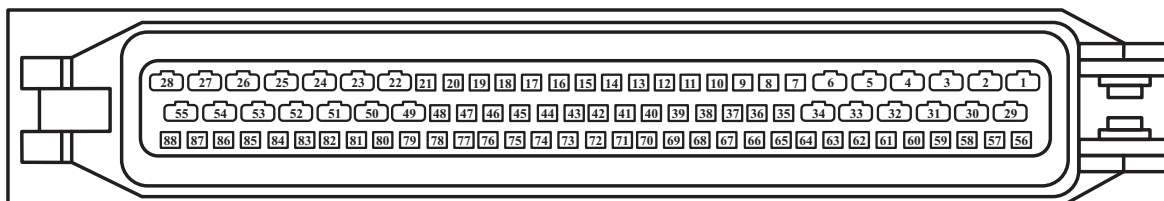

Figure 128



TECHNICIANS DIAGNOSTIC GUIDE BMW, AUDI, PORSCHE

RETRIEVING FAULT CODES

The BMW, Audi, Porsche Diagnostic Tool is *required* to retrieve the fault codes that are stored in the control unit. The diagnostic tool has the ability to retrieve codes, clear codes and activate individual components, and is adaptable to 3 Series, 5 Series, 7 Series and 8 Series vehicles equipped with 4HP-22/24, 4L30-E, 4HP-18FLE, 5HP-18, 5HP-19, and 5HP-30. The BMW, Audi, Porsche Diagnostic Tool can be purchased from:

Assenmacher Specialty Tools, Inc
Phone (303) 530-2424 Fax (303) 530-4720

BMW ZF-5HP-30 FAULT CODE CHART

<i>Code</i>	<i>Description and TCM Terminal I.D.</i>	<i>Possible Causes</i>
01	Pressure Regulator, EDS 2 - Pin 1	Questionable signal, or break or short in wiring
02	Park-Neutral Lock Solenoid - Pin 2	Break or short in wiring
04	Pressure Regulator, EDS 4 - Pin 4	Questionable signal, or break or short in wiring
05	Pressure Regulator, EDS 1 - Pin 5	Questionable signal, or break or short in wiring
08	Selector Lever Position L2 - Pin 8	Vehicle acceleration detected while selector lever in P or N position, or engine has been started even though EGS control unit has not detected a selector lever position of P or N
09	Selector Lever Position L3/L4 - Pins 37 and 9	Engine has been started even though EGS control unit has not detected a selector lever position of P or N
0C	Program Selector Switch - Pins 12, 13 and 45	Short in wiring, or more than one program selector switch input is applied to ground
10	Rotational Speed Sensor, Turbocharger Pins 16 and 44	No input, or incorrect engine speed information
12	Kickdown Switch - Pin 18	Questionable signal
13	ASC Monitoring - Pin 19	ASC operation has been detected while selector lever was in Park or Neutral position
16	TOT Sensor - Pins 21 and 22	Resistance of TOT Sensor not within permissible range
1A	Battery Voltage Supply - Pin 26	Break in wiring
1D	Pressure Regulator, EDS 3 - Pin 29	Questionable signal, or break or short in wiring
1E	MV 1 Solenoid - Pin 30	Break or short in wiring, or defective winding in solenoid
20	MV 3 Solenoid - Pin 32	Break or short in wiring, or defective winding in solenoid
21	MV 2 Solenoid - Pin 33	Break or short in wiring, or defective winding in solenoid
24	Selector Lever Position L1 - Pin 36	Break or short in wiring, or defective sensor
2A	Output Speed Sensor signal and Stall Speed signal - Pins 13 and 42	No input, or incorrect engine speed information
33	Pressure Regulator, EDS 5 - Pin 51	Questionable signal, or break or short in wiring
34	Power Supply to transmission - Pin 52	Break or short in wiring

Copyright © 2003 ATSG

Figure 129

BMW ZF-5HP-30 FAULT CODE CHART

Code	Description and TCM Terminal I.D.	Possible Causes
36	Power Supply - Pin 54	Power Supply less than 9 volts at engine speeds greater than 1600 RPM
64	Speed Monitoring	Faulty Speed Sensor signal, or slip in Transmission
65	EPROM - Checksum	Program memory in Transmission Control Unit faulty
66	Incorrect Program Checksum	Program memory in Transmission Control Unit faulty
67	Transmission Relay - Pin 52	Pickup and dropout times too long
68	Over-revving Lock	Engine RPM greater than 6816 has been detected
69	Speed Monitoring	Faulty Speed Sensor signal, or slip in Transmission
6A	Speed Monitoring	Faulty Speed Sensor signal, or slip in Transmission
96	CAN Timeout 1	CAN signal not sent during initialization (Ignition On)
97	CAN Timeout 2	CAN signal not sent during operation
98	CAN Bus monitoring	Values in CAN RAM are not updated
99	CAN status fault	
9A	CAN throttle valve information	DME detects faulty throttle valve signal
9B	CAN load signal information	DME detects faulty load signal
9C	CAN engine intervention	DME cannot carry out reduction in engine torque desire by the EGS, or DME has different requirements compared to other CAN users
9D	CAN engine temperature info	DME detects faulty engine temperature signal

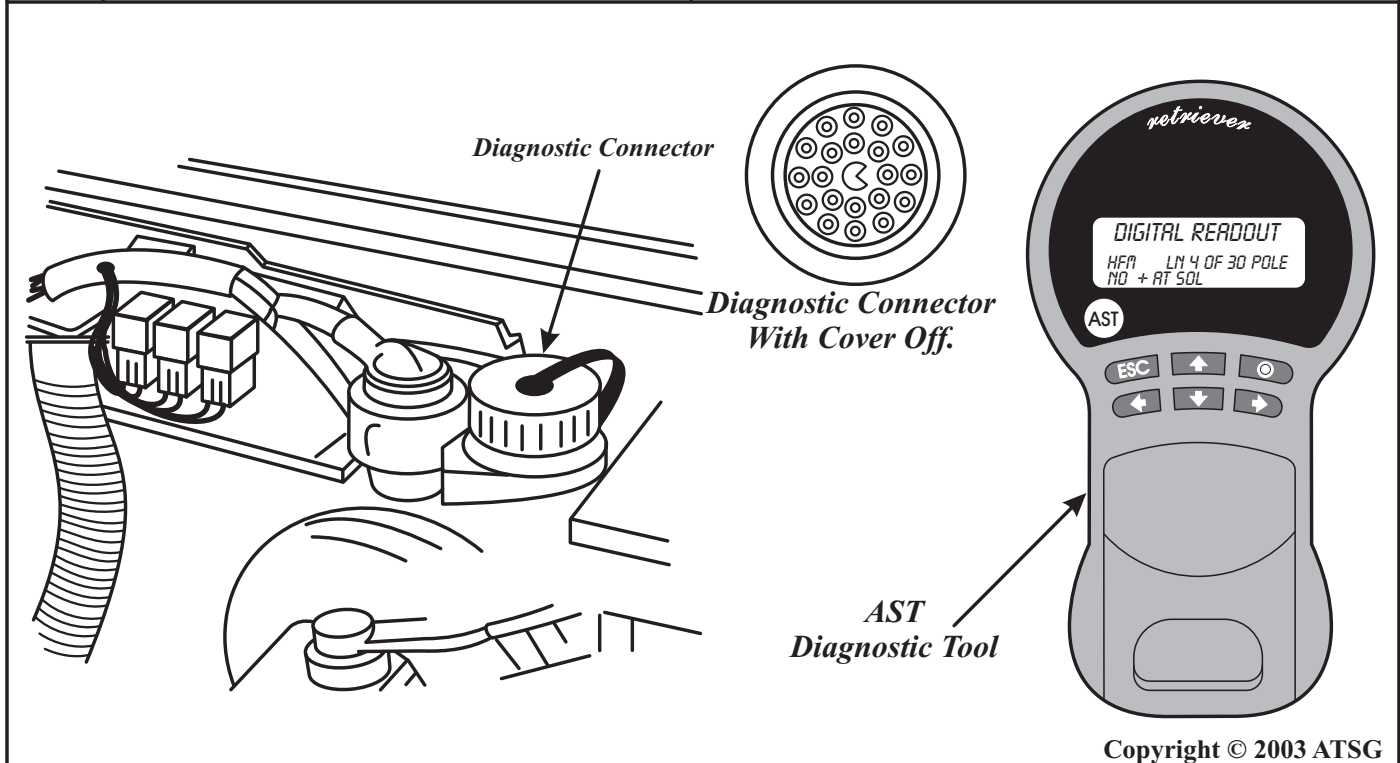
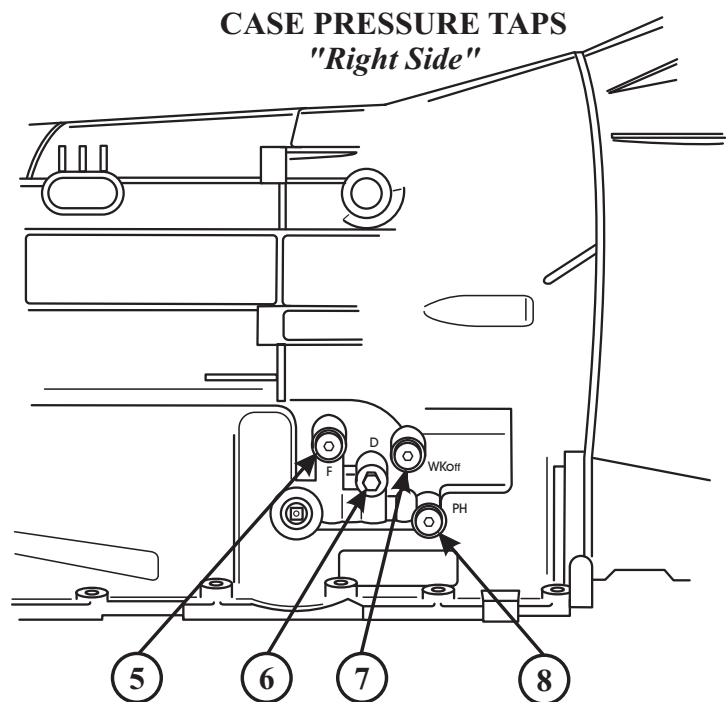
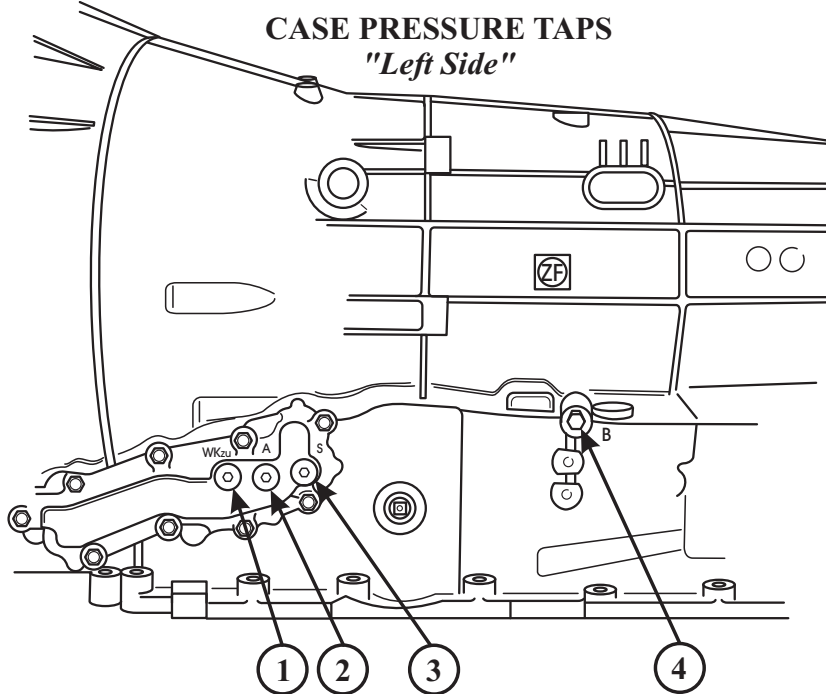

Figure 130



1. *WKzu = Converter Clutch ON Pressure.*
2. *A = "A" Clutch Pressure.*
3. *S = Cooler Pressure.*
4. *B = "B" Clutch Pressure (Must Drill and Tap for Access).*
5. *F = "F" Clutch Pressure.*
6. *D = "D" Clutch Pressure (Must Drill and Tap for Access).*
7. *WKoff = Converter Clutch OFF Pressure.*
8. *PH = Line Pressure.*

Copyright © 2003 ATSG

Figure 131

ZF-5HP-30
UPPER REAR VALVE BODY

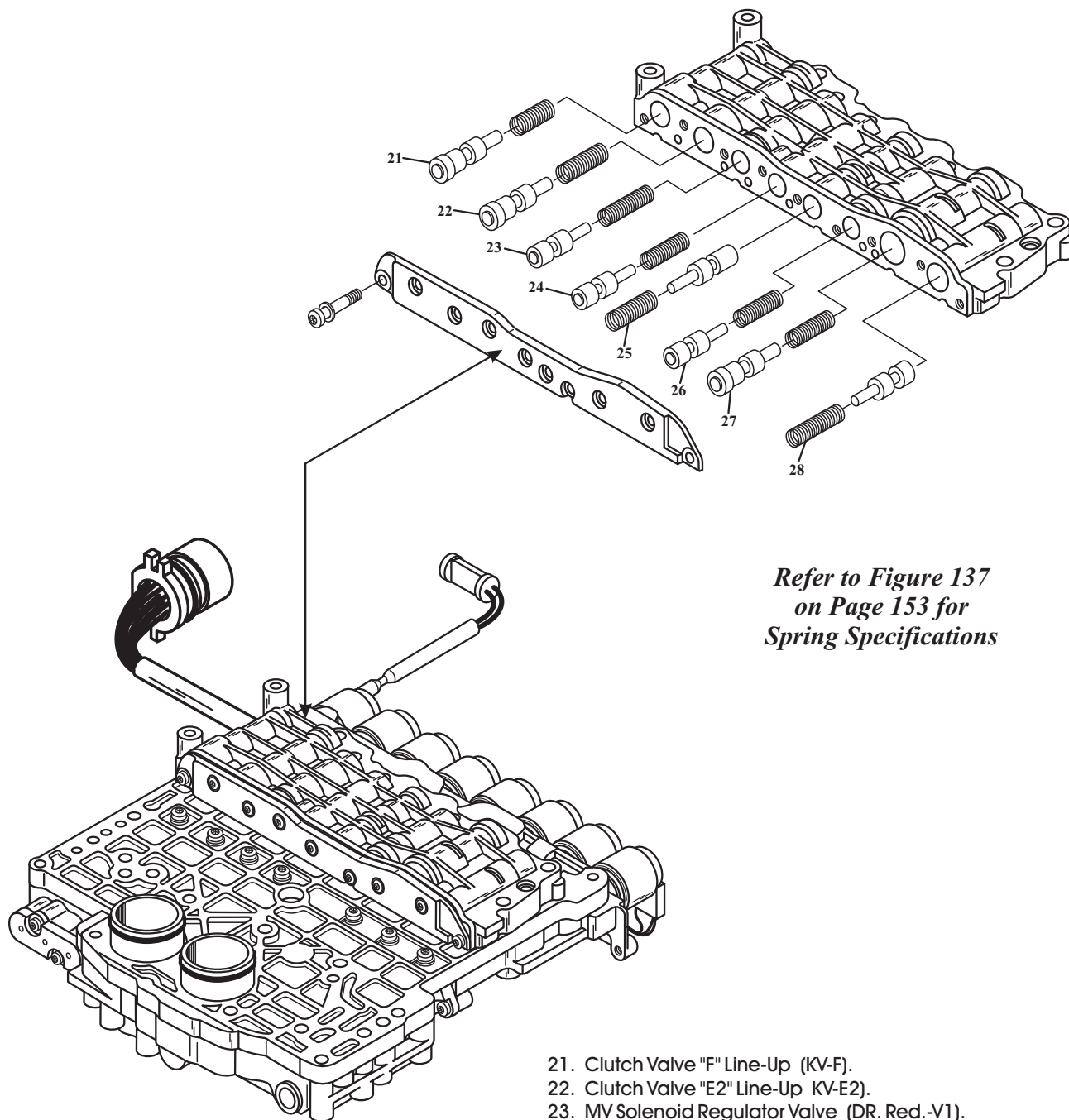

*Refer to Figure 137
on Page 153 for
Spring Specifications*

- 21. Clutch Valve "F" Line-Up (KV-F).
- 22. Clutch Valve "E2" Line-Up (KV-E2).
- 23. MV Solenoid Regulator Valve (DR. Red.-V1).
- 24. EDS Solenoid Regulator Valve (DR. Red.-V2).
- 25. Clutch Valve "B" Line-Up (KV-B).
- 26. Clutch Valve "E1" Line-Up (KV-E1).
- 27. Switch Valve For "A" Clutch (ABSCH-V-A).

Figure 132

ZF-5HP-30
LOWER FRONT VALVE BODY

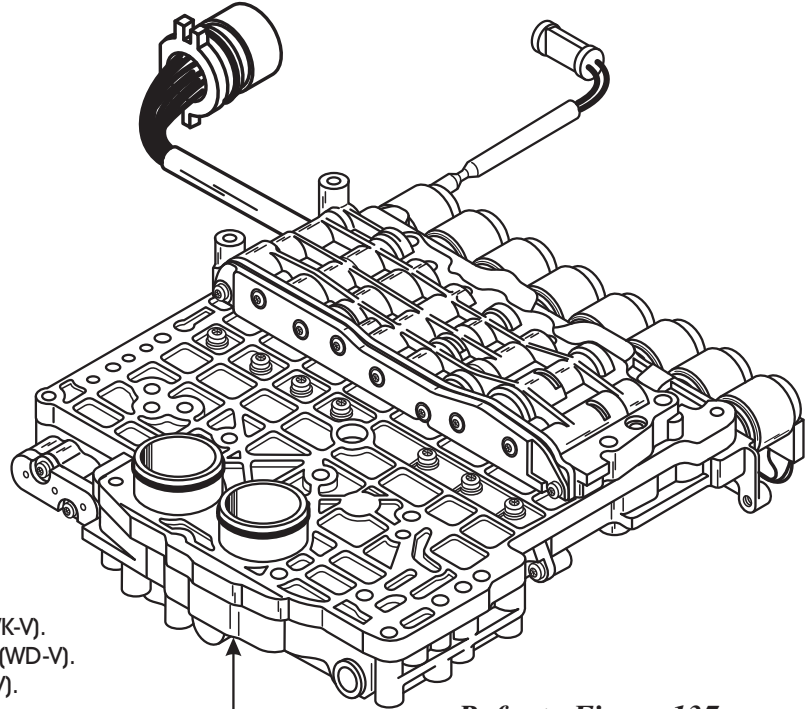

- 9. Manual Shift Valve (W-S).
- 10. Converter Clutch Apply Oil Control Valve (WK-V).
- 11. Converter Clutch Release Oil Control Valve (WD-V).
- 12. Main Pressure Regulator Valve Line-Up (HD-V).
- 13. Lubrication Valve (SCHM-V)
- 14. Modulating Valve Line-Up (MOD-V).
- 15. Main Regulator Valve For "B" Clutch (HV-B).
- 16. Accumulator Valve For EDS 2 Solenoid (D-2).
- 17. Main Regulator Valve For "D" Clutch (HV-D).
- 18. Accumulator Valve For EDS 4 Solenoid (D-4).
- 19. Accumulator Valve For EDS 5 Solenoid (D-5).
- 20. Accumulator Valve For EDS 3 Solenoid (D-3).

*Refer to Figure 137
on Page 153 for
Spring Specifications*

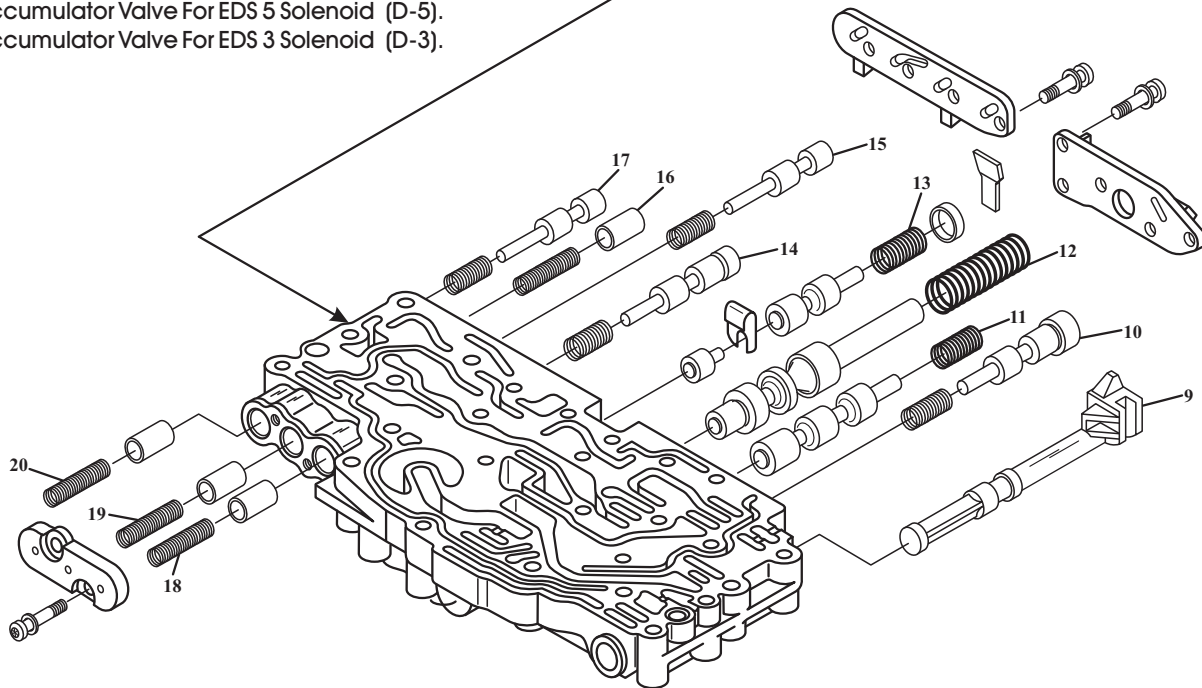

Copyright © 2003 ATSG

Figure 133

ZF-5HP-30
LOWER REAR VALVE BODY

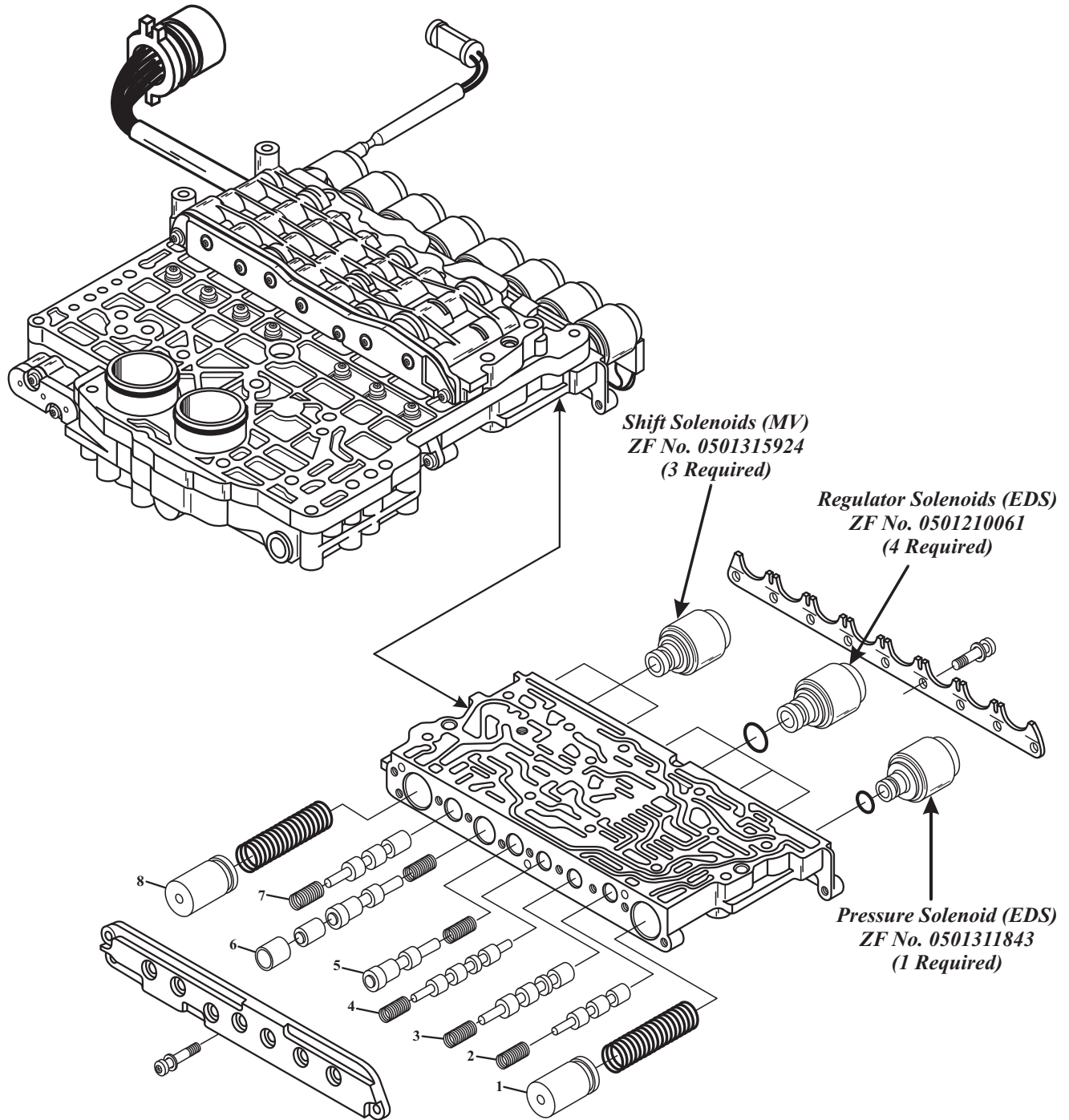

1. "A" Clutch Accumulator Line-Up (D-A).
2. Shift Valve Number 1 (SV-1).
3. Shift Valve Number 2 (SV-2).
4. Shift Valve Number 3 (SV-3).
5. Switch Valve For "D" Clutch (ABSCH-V-D).
6. Clutch Valve "D" Line-Up (KV-D).
7. Reverse Gear Valve Line-Up (RG-V).

*Refer to Figure 137
on Page 153 for
Spring Specifications*

Figure 134

UPPER REAR VALVE BODY

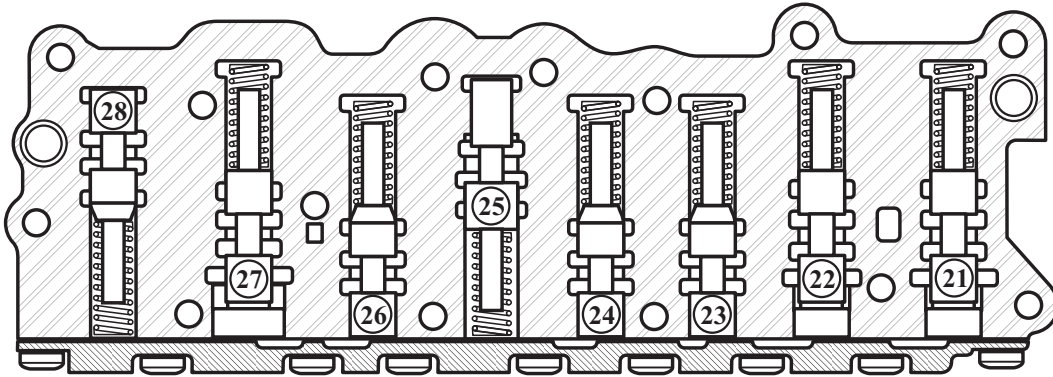

- 21. Clutch Valve "F" Line-Up (KV-F).
- 22. Clutch Valve "E2" Line-Up KV-E2).
- 23. MV Solenoid Regulator Valve (DR. Red.-V1).
- 24. EDS Solenoid Regulator Valve (DR. Red.-V2).
- 25. Clutch Valve "B" Line-Up (KV-B).
- 26. Clutch Valve "E1" Line-Up (KV-E1).
- 27. Switch Valve For "A" Clutch (ABSCH-V-A).

*Only One .250" (6.35mm) ball is located here.
 Do Not install a ball in the pocket marked X.*

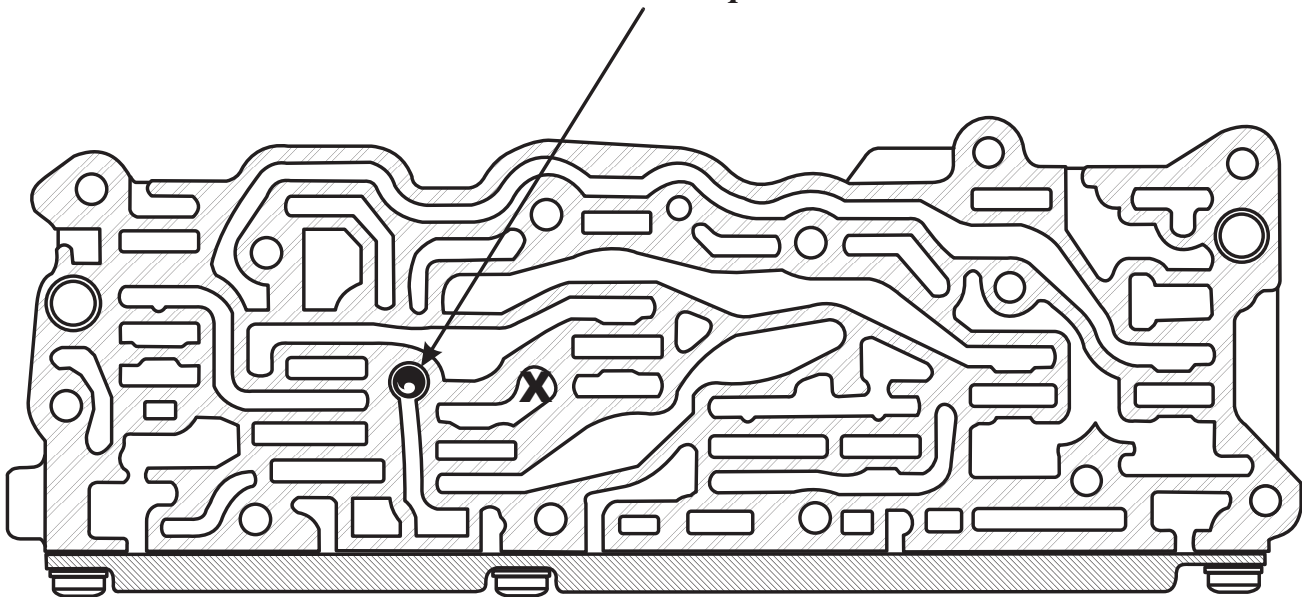

Figure 135

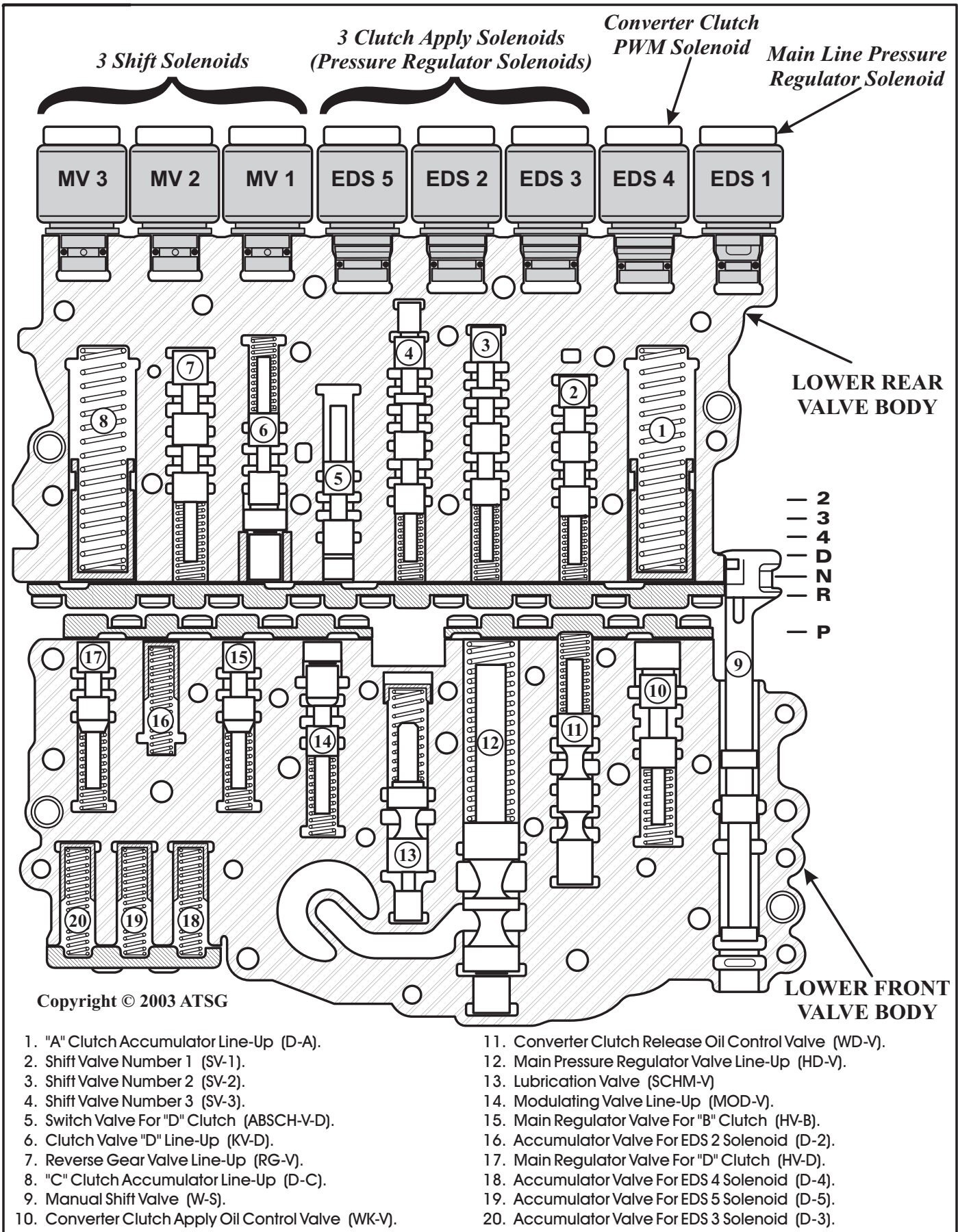

Figure 136

ZF 5HP-30 VALVE BODY SPRING SPECIFICATIONS

UPPER REAR VALVE BODY

- | | | |
|--|---|--|
| <p>21. Clutch Valve "F" (KV-F)
Free Length = 1.370"
Wire Diameter = .030"
Outside Diameter = .365"</p> | <p>24. EDS Solenoid Reg Valve (DR-V2)
Free Length = 1.980"
Wire Diameter = .045"
Outside Diameter = .370"</p> | <p>27. A Clutch Swit Valve (ABSCH.V-A)
Free Length = 1.692"
Wire Diameter = .031"
Outside Diameter = .365"</p> |
| <p>22. Clutch Valve "E2" (KV-E2)
Free Length = 1.558"
Wire Diameter = .031"
Outside Diameter = .365"</p> | <p>25. Clutch Valve "B" (KV-B)
Free Length = 1.710"
Wire Diameter = .042"
Outside Diameter = .424"</p> | <p>28. Clutch Valve "A" (KV-A)
Free Length = 1.792"
Wire Diameter = .031"
Outside Diameter = .358"</p> |
| <p>23. MV Solenoid Reg Valve (DR-V1)
Free Length = 1.395"
Wire Diameter = .038"
Outside Diameter = .301"</p> | <p>26. Clutch Valve "E1" (KV-E1)
Free Length = 1.742"
Wire Diameter = .023"
Outside Diameter = .352"</p> | <p><i>These spring locations
shown on Page 148.</i></p> |

LOWER "FRONT" VALVE BODY

- | | | |
|---|---|---|
| <p>10. TCC Apply Control Valve (WK-V)
Free Length = 1.628"
Wire Diameter = .048"
Outside Diameter = .440"</p> | <p>14. Modulating Valve (MOD-V)
Free Length = 1.493"
Wire Diameter = .031"
Outside Diameter = .365"</p> | <p>18. EDS 4, Accumulator Valve (D-4)
Free Length = 1.530"
Wire Diameter = .042"
Outside Diameter = .322"</p> |
| <p>11. TCC Release Control Valve (WD-V)
Free Length = 2.007"
Wire Diameter = .034"
Outside Diameter = .438"</p> | <p>15. "B" Clutch Reg Valve (HV-B)
Free Length = 1.414"
Wire Diameter = .030"
Outside Diameter = .365"</p> | <p>19. EDS 5, Accumulator Valve (D-5)
Free Length = 1.530"
Wire Diameter = .042"
Outside Diameter = .322"</p> |
| <p>12. Pressure Regulator Valve (HD-V)
Free Length = 3.548"
Wire Diameter = .087"
Outside Diameter = .686"</p> | <p>16. EDS 2, Accumulator Valve (D-2)
Free Length = 1.530"
Wire Diameter = .042"
Outside Diameter = .322"</p> | <p>20. EDS 3, Accumulator Valve (D-3)
Free Length = 1.530"
Wire Diameter = .042"
Outside Diameter = .322"</p> |
| <p>13. Lubrication Valve (SCHM.-V)
Free Length = 1.750"
Wire Diameter = .048"
Outside Diameter = .480"</p> | <p>17. "D" Clutch Reg Valve (HV-D)
Free Length = 1.543"
Wire Diameter = .042"
Outside Diameter = .348"</p> | <p><i>These spring locations
shown on Page 149.</i></p> |

LOWER "REAR" VALVE BODY

- | | | |
|--|---|--|
| <p>1. "A" Clutch Accumulator (D-A)
Free Length = 2.929"
Wire Diameter = .066"
Outside Diameter = .608"</p> | <p>4. Shift Valve Number 3 (SV-3)
Free Length = 1.640"
Wire Diameter = .031"
Outside Diameter = .366"</p> | <p>7. Reverse Gear Valve (RG-V)
Free Length = 1.836"
Wire Diameter = .038"
Outside Diameter = .435"</p> |
| <p>2. Shift Valve Number 1 (SV-1)
Free Length = 1.800"
Wire Diameter = .031"
Outside Diameter = .360"</p> | <p>5. Switch Valve "D" Clutch (ABSCH.V-D)
Free Length = 1.733"
Wire Diameter = .023"
Outside Diameter = .350"</p> | <p>8. "C" Clutch Accumulator (D-C)
Free Length = 2.929"
Wire Diameter = .066"
Outside Diameter = .608"</p> |
| <p>3. Shift Valve Number 2 (SV-2)
Free Length = 1.800"
Wire Diameter = .031"
Outside Diameter = .360"</p> | <p>6. Clutch Valve "D" Line-Up (KV-D)
Free Length = 1.763"
Wire Diameter = .031"
Outside Diameter = .360"</p> | <p><i>These spring locations
shown on Page 150.</i></p> |

Note: There is now available from ZF distributors a "Valve Body Kit" for the 5HP-30 that includes all new stock springs, all check balls, all orifices and screens. ZF part number "5HP-30 VBK".

Note: The number in front of the name of the valve line-up is the illustration number in the ATSG illustrations in this manual.

Figure 137

**ZF-5HP-30 CHANNEL PLATE
UPPER VALVE BODY SIDE**

Round Screen

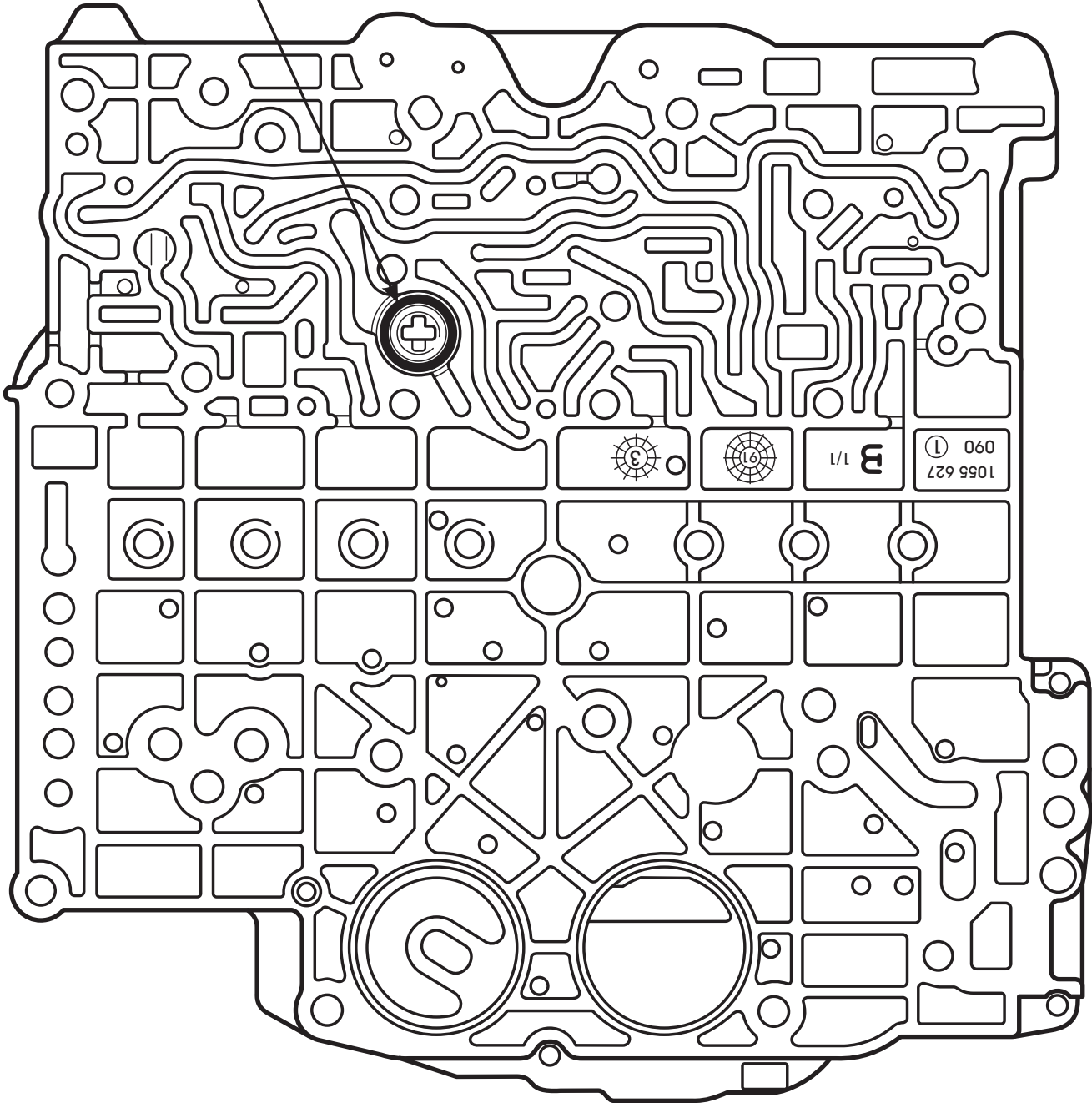
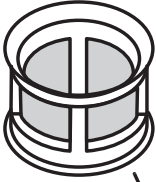

Copyright © 2003 ATSG

Figure 138

**ZF-5HP-30 CHANNEL PLATE
LOWER VALVE BODY SIDE**

*Replace the original ball with
a plastic .250" (6.35mm) ball.*

*Original
.236" Diameter*

*.039"
Flat Orifice*

*.048"
Flat Orifice*

*.048"
Flat Orifice*

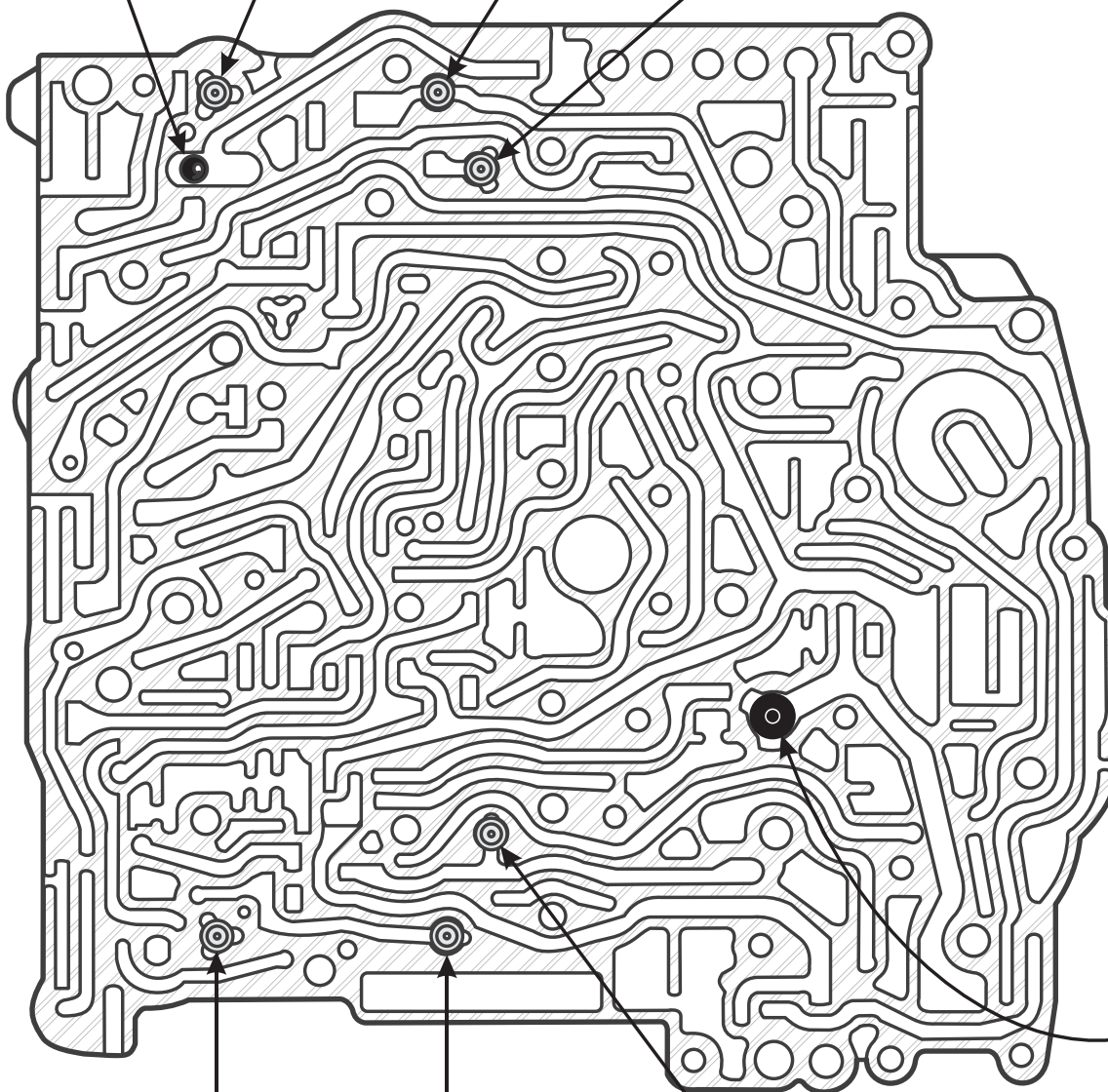

*PLASTIC VALVE
AND SPRING*

*.039"
Flat Orifice*

*.048"
Flat Orifice*

*.067"
Flat Orifice*

Copyright © 2003 ATSG

Figure 139



TECHNICIANS DIAGNOSTIC GUIDE BMW, AUDI, PORSCHE

BMW ZF 5-HP-30 NO REVERSE

COMPLAINT: 1991 and later BMW vehicles equipped with the ZF 5-HP-30 transmission may exhibit a no reverse condition, when the selector lever is placed into reverse.

CAUSE: The cause may be, the .236" diameter checkball located in the bathtub in the channel plate has blown through the spacer plate, which will now exhaust "F" clutch (Reverse) oil pressure.

CORRECTION: Install a .250" diameter plastic checkball into the bathtub in the channel plate as shown in Figure 140. The holes in the spacer plate over the bathtub measure .198" and the larger diameter checkball will greatly decrease the probability of this condition occurring again. There is also ample room in the bathtub for the increased diameter of the checkball to perform its duties. Refer to Figure 140. Figure 141 illustrates the location of the only other checkball in this unit and, *do not install checkball in the location marked "X"*.

SPECIAL NOTE: The checkball wearing and blowing through the spacer plate causing the loss of reverse, may also have caused some damage to the "C" Clutch, which is also on in reverse. This condition has also been known to create damage to the "A"/"C" Clutch Housing as well. If the clutch housing has been severely damaged, aluminum material will be evident in the bottom pan upon inspection.

When the unit is removed and the "A"/"C" Clutch Housing is dis-assembled, it is not uncommon for the unit to set for over a week waiting on parts. When re-assembling, it is *very easy to mis-assemble the "B" Clutch Hub* on top of the retaining snap ring for the "A" Clutch pack. This mis-assembly will allow the "B" clutch hub to move out of the A/C clutch housing and create a neutralizing on the 3-4 upshift, and the Trans light will begin flashing. *Ensure that you assemble the "B" Clutch Hub on top of the "A" Clutch stack, and then install the "A" Clutch Pressure Plate and snap ring, as shown in Figures 142 and 143.*

ZF-5HP-30 CHANNEL PLATE
LOWER VALVE BODY SIDE

*Replace the original ball with
a plastic .250" (6.35mm) ball.*

*Original
.236" Diameter*

*.039"
Flat Orifice*

*.048"
Flat Orifice*

*.048"
Flat Orifice*

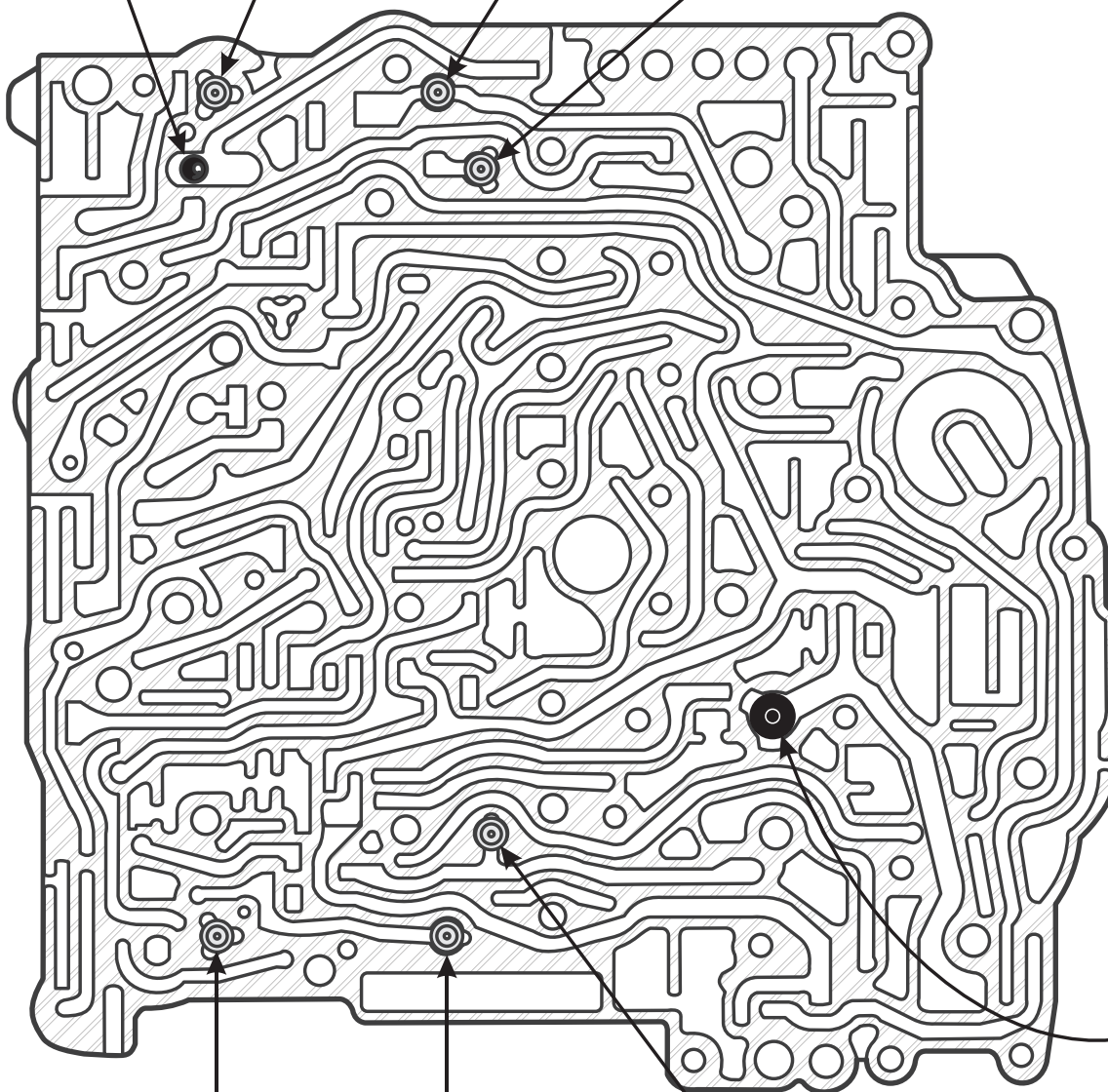

*PLASTIC VALVE
AND SPRING*

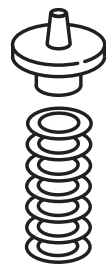

*.039"
Flat Orifice*

*.048"
Flat Orifice*

*.067"
Flat Orifice*



Copyright © 2003 ATSG

Figure 140

TECHNICIANS DIAGNOSTIC GUIDE
BMW, AUDI, PORSCHE

UPPER REAR VALVE BODY
CHECKBALL LOCATION

*Only One .250" (6.35mm) ball is located here.
Do Not install a ball in the pocket marked X.*

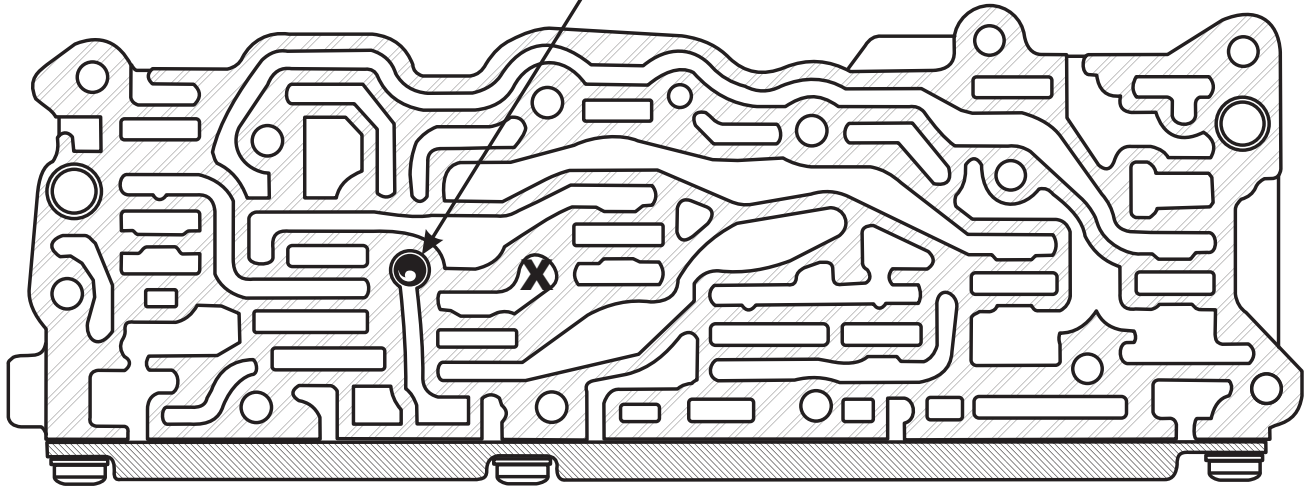

Copyright © 2003 ATSG

Figure 141

"A"/"C" CLUTCH HOUSING COMPONENTS

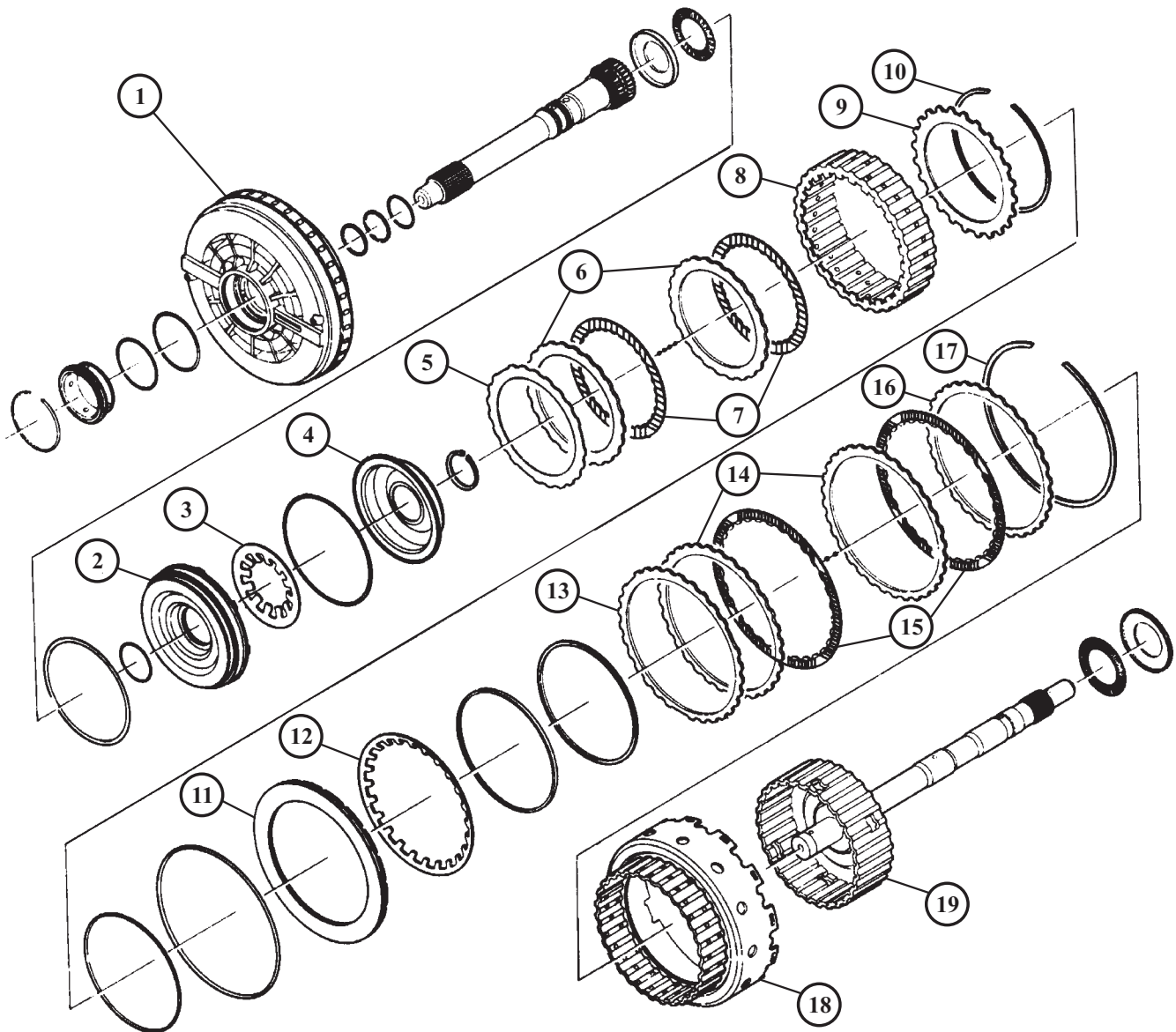

- 1. "A"/"C" Clutch Housing Assembly
- 2. "A" Clutch Apply Piston
- 3. "A" Clutch Bellville Return Spring
- 4. "A" Clutch Piston Oil Dam
- 5. "A" Clutch Cushion Plate
- 6. "A" Clutch Steel Plates (5 Required)
- 7. "A" Clutch Friction Plates (5 Required)
- 8. "B" Clutch Hub
- 9. "A" Clutch Pressure Plate
- 10. "A" Clutch Pressure Plate Snap Ring

- 11. "C" Clutch Apply Piston
- 12. "C" Clutch Apply Piston Return Spring
- 13. "C" Clutch Cushion Plate
- 14. "C" Clutch Steel Plates (3 Required)
- 15. "C" Clutch Friction Plates (3 Required)
- 16. "C" Clutch Pressure Plate
- 17. "C" Clutch Pressure Plate Snap Ring
- 18. "C" Clutch Hub
- 19. "A" Clutch Hub And Input Shaft

Copyright © 2003 ATSG

Figure 142

A/C CLUTCH HOUSING CUT-AWAY

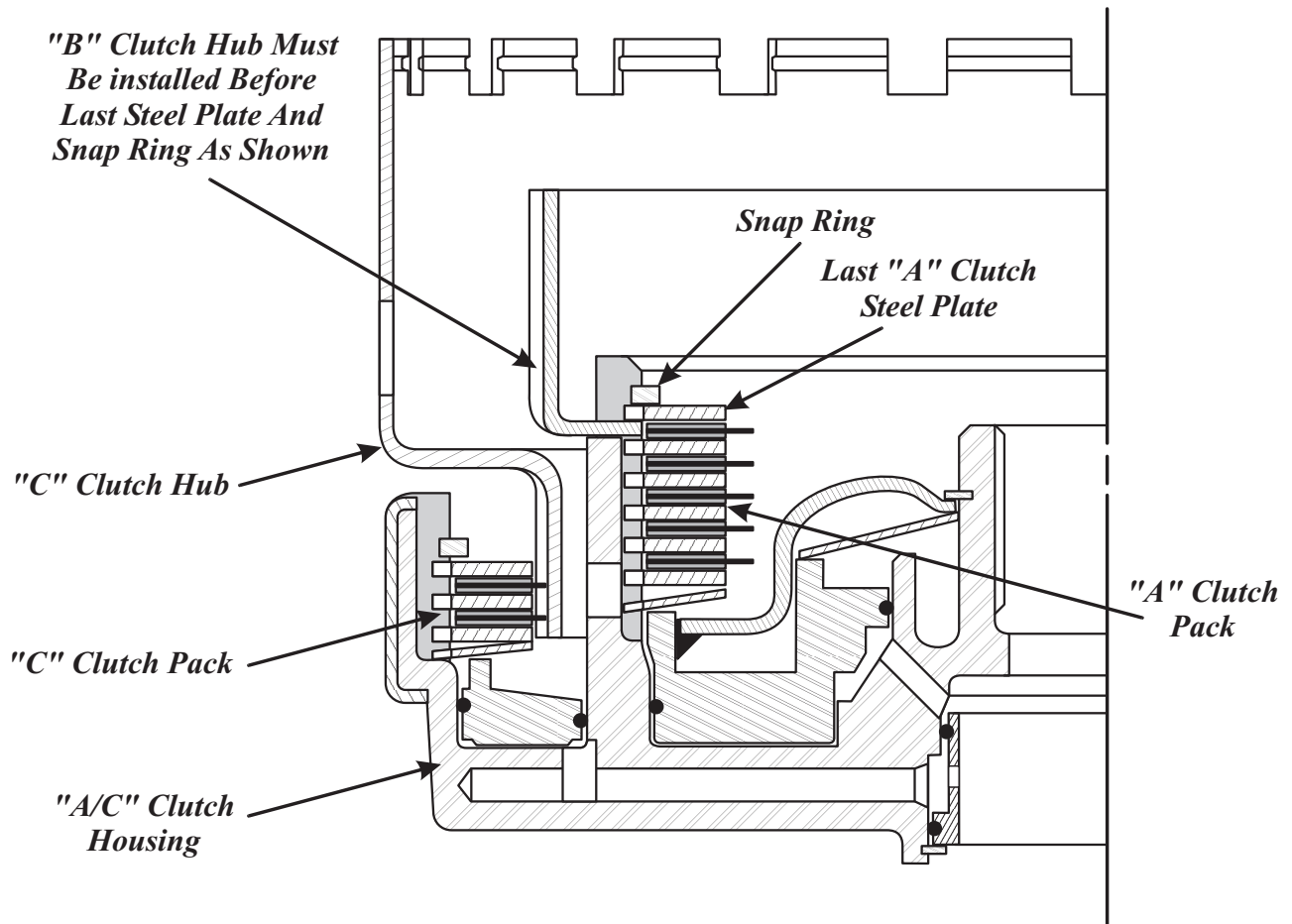

Figure 143