

SECTION **CVT**

CVT

A
B

CVT

D

E

CONTENTS

INDEX FOR DTC	6	Input/Output Signal of TCM	20	F
Alphabetical Index	6	Line Pressure and Secondary Pressure Control ...	21	
DTC No. Index	7	NORMAL CONTROL	21	
PRECAUTIONS	8	FEEDBACK CONTROL	21	G
Precautions for Supplemental Restraint System		Shift Control	21	
(SRS) "AIR BAG" and "SEAT BELT PRE-TEN-		"D" POSITION	22	H
SIONER"	8	"M" POSITION	22	
On Board Diagnostic (OBD) System of CVT and		DOWNHILL ENGINE BRAKE CONTROL (AUTO		H
Engine	8	ENGINE BRAKE CONTROL)	22	
Precautions for TCM and CVT Assembly Replace-		ACCELERATION CONTROL	22	
ment	8	Lock-up and Select Control	22	I
EEPROM ERASING PATTERNS	8	TORQUE CONVERTER CLUTCH AND SELECT		
METHOD FOR ERASING THE EEPROM IN THE		CONTROL VALVE CONTROL	23	J
TCM	9	Control Valve	24	
METHOD FOR WRITING DATA FROM THE		FUNCTION OF CONTROL VALVE	24	J
ROM ASSEMBLY IN THE TRANSAXLE	9	ON BOARD DIAGNOSTIC (OBD) SYSTEM	25	K
CHECK METHOD	9	Introduction	25	
Removal and Installation Procedure for CVT Unit		OBD-II Function for CVT System	25	
Connector	9	One or Two Trip Detection Logic of OBD-II	25	
REMOVAL	9	ONE TRIP DETECTION LOGIC	25	
INSTALLATION	10	TWO TRIP DETECTION LOGIC	25	L
Precautions	10	OBD-II Diagnostic Trouble Code (DTC)	25	
Service Notice or Precautions	11	HOW TO READ DTC AND 1ST TRIP DTC	25	
OBD-II SELF-DIAGNOSIS	11	HOW TO ERASE DTC	26	
Wiring Diagrams and Trouble Diagnosis	11	HOW TO ERASE DTC (WITH CONSULT-II)	27	
PREPARATION	12	HOW TO ERASE DTC (WITH GST)	27	M
Special Service Tools	12	Malfunction Indicator (MI)	28	
Commercial Service Tools	13	DESCRIPTION	28	
CVT FLUID	14	TROUBLE DIAGNOSIS	29	
Checking CVT Fluid	14	DTC Inspection Priority Chart	29	
Changing CVT Fluid	15	Fail-safe	29	
CVT SYSTEM	16	FAIL-SAFE FUNCTION	29	
Cross-Sectional View - RE0F09A	16	How to Perform Trouble Diagnosis for Quick and		
Control System	17	Accurate Repair	30	
Hydraulic Control System	18	INTRODUCTION	30	
TCM Function	19	WORK FLOW	31	
CONTROL SYSTEM OUTLINE	19	DIAGNOSTIC WORKSHEET	32	
CONTROL SYSTEM DIAGRAM	19	CVT Electrical Parts Location	35	
CAN Communication	20	Circuit Diagram	36	
SYSTEM DESCRIPTION	20	Inspections Before Trouble Diagnosis	37	

CVT FLUID CHECK	37	Wiring Diagram — CVT — PNP/SW	76
STALL TEST	37	Diagnostic Procedure	78
LINE PRESSURE TEST	39	Component Inspection	80
Road Test	41	PNP SWITCH	80
DESCRIPTION	41	DTC P0710 CVT FLUID TEMPERATURE SENSOR	
CONSULT-II SETTING PROCEDURE	41	CIRCUIT	81
Check Before Engine Is Started	44	Description	81
Check at Idle	44	CONSULT-II Reference Value	81
Cruise Test	47	On Board Diagnosis Logic	81
Vehicle Speed at Which Gear Shifting Occurs	49	Possible Cause	81
TCM Input/Output Signal Reference Values	50	DTC Confirmation Procedure	81
TCM TERMINAL CONNECTOR LAYOUT	50	WITH CONSULT-II	81
TCM INSPECTION TABLE	50	WITH GST	81
CONSULT-II Function (TRANSMISSION)	53	Wiring Diagram — CVT — FTS	82
FUNCTION	53	Diagnostic Procedure	83
CONSULT-II REFERENCE VALUE	53	Component Inspection	85
CONSULT-II SETTING PROCEDURE	55	CVT FLUID TEMPERATURE SENSOR	85
WORK SUPPORT MODE	56	DTC P0715 INPUT SPEED SENSOR CIRCUIT (PRI	
SELF-DIAGNOSTIC RESULT MODE	58	SPEED SENSOR)	86
DATA MONITOR MODE	61	Description	86
CAN DIAGNOSTIC SUPPORT MONITOR		CONSULT-II Reference Value	86
MODE	63	On Board Diagnosis Logic	86
Diagnostic Procedure Without CONSULT-II	64	Possible Cause	86
OBD-II SELF-DIAGNOSTIC PROCEDURE		DTC Confirmation Procedure	86
(WITH GST)	64	WITH CONSULT-II	86
DTC U1000 CAN COMMUNICATION LINE	65	WITH GST	86
Description	65	Wiring Diagram — CVT — PRSCVT	87
On Board Diagnosis Logic	65	Diagnostic Procedure	88
Possible Cause	65	DTC P0720 VEHICLE SPEED SENSOR CVT (SEC-	
DTC Confirmation Procedure	65	ONDARY SPEED SENSOR)	91
WITH CONSULT-II	65	Description	91
WITH GST	65	CONSULT-II Reference Value	91
Wiring Diagram — CVT — CAN	66	On Board Diagnosis Logic	91
Diagnostic Procedure	67	Possible Cause	91
DTC P0615 START SIGNAL CIRCUIT	68	DTC Confirmation Procedure	91
Description	68	WITH CONSULT-II	91
CONSULT-II Reference Value	68	WITH GST	91
On Board Diagnosis Logic	68	Wiring Diagram — CVT — SESCOVT	92
Possible Cause	68	Diagnostic Procedure	93
DTC Confirmation Procedure	68	DTC P0725 ENGINE SPEED SIGNAL	97
WITH CONSULT-II	68	Description	97
Wiring Diagram — CVT — STSIG	69	CONSULT-II Reference Value	97
Diagnostic Procedure	70	On Board Diagnosis Logic	97
DTC P0703 STOP LAMP SWITCH CIRCUIT	72	Possible Cause	97
Description	72	DTC Confirmation Procedure	97
CONSULT-II Reference Value	72	WITH CONSULT-II	97
On Board Diagnosis Logic	72	Diagnostic Procedure	97
Possible Cause	72	DTC P0730 BELT DAMAGE	99
DTC Confirmation Procedure	72	Description	99
WITH CONSULT-II	72	CONSULT-II Reference Value	99
Diagnostic Procedure	73	On Board Diagnosis Logic	99
DTC P0705 PARK/NEUTRAL POSITION SWITCH..	74	Possible Cause	99
Description	74	DTC Confirmation Procedure	99
CONSULT-II Reference Value	74	WITH CONSULT-II	99
On Board Diagnosis Logic	74	Diagnostic Procedure	100
Possible Cause	74	DTC P0740 TORQUE CONVERTER CLUTCH	
DTC Confirmation Procedure	74	SOLENOID VALVE	101
WITH CONSULT-II	75	Description	101
WITH GST	75	CONSULT-II Reference Value	101

On Board Diagnosis Logic	101	On Board Diagnosis Logic	120
Possible Cause	101	Possible Cause	120
DTC Confirmation Procedure	101	DTC Confirmation Procedure	120
WITH CONSULT-II	101	WITH CONSULT-II	120
WITH GST	101	WITH GST	120
Wiring Diagram — CVT — TCV	102	Wiring Diagram — CVT — SECPSV	121
Diagnostic Procedure	103	Diagnostic Procedure	122
Component Inspection	105	Component Inspection	124
TORQUE CONVERTER CLUTCH SOLENOID VALVE	105	PRESSURE CONTROL SOLENOID VALVE B (SECONDARY PRESSURE SOLENOID VALVE)	124
DTC P0744 A/T TCC S/V FUNCTION (LOCK-UP) 106		DTC P0826 MANUAL MODE SWITCH CIRCUIT .. 125	
Description	106	Description	125
CONSULT-II Reference Value	106	CONSULT-II Reference Value	125
On Board Diagnosis Logic	106	On Board Diagnosis Logic	125
Possible Cause	106	Possible Cause	125
DTC Confirmation Procedure	106	DTC Confirmation Procedure	125
WITH CONSULT-II	106	WITH CONSULT-II	125
WITH GST	106	Wiring Diagram — CVT — MMSW (LHD Models)	126
Diagnostic Procedure	107	Wiring Diagram — CVT — MMSW (RHD Models)	128
DTC P0745 LINE PRESSURE SOLENOID VALVE 109		Diagnostic Procedure	129
Description	109	Component Inspection	131
CONSULT-II Reference Value	109	MANUAL MODE SWITCH	131
On Board Diagnosis Logic	109	DTC P0840 TRANSMISSION FLUID PRESSURE SENSOR A CIRCUIT (SEC PRESSURE SENSOR) 132	
Possible Cause	109	Description	132
DTC Confirmation Procedure	109	CONSULT-II Reference Value	132
WITH CONSULT-II	109	On Board Diagnosis Logic	132
WITH GST	109	Possible Cause	132
Wiring Diagram — CVT — LPSV	110	DTC Confirmation Procedure	132
Diagnostic Procedure	111	WITH CONSULT-II	132
Component Inspection	113	WITH GST	132
PRESSURE CONTROL SOLENOID VALVE A (LINE PRESSURE SOLENOID VALVE)	113	Wiring Diagram — CVT — SECPS	133
DTC P0746 PRESSURE CONTROL SOLENOID A PERFORMANCE (LINE PRESSURE SOLENOID VALVE) 114		Diagnostic Procedure	134
Description	114	DTC P0841 PRESSURE SENSOR FUNCTION 137	
CONSULT-II Reference Value	114	Description	137
On Board Diagnosis Logic	114	CONSULT-II Reference Value	137
Possible Cause	114	On Board Diagnosis Logic	137
DTC Confirmation Procedure	114	Possible Cause	137
WITH CONSULT-II	114	DTC Confirmation Procedure	137
WITH GST	114	WITH CONSULT-II	137
Diagnostic Procedure	115	Diagnostic Procedure	138
DTC P0776 PRESSURE CONTROL SOLENOID B PERFORMANCE (SEC PRESSURE SOLENOID VALVE) 117		DTC P0845 TRANSMISSION FLUID PRESSURE SENSOR B CIRCUIT (PRI PRESSURE SENSOR) 140	
Description	117	Description	140
CONSULT-II Reference Value	117	CONSULT-II Reference Value	140
On Board Diagnosis Logic	117	On Board Diagnosis Logic	140
Possible Cause	117	Possible Cause	140
DTC Confirmation Procedure	117	DTC Confirmation Procedure	140
WITH CONSULT-II	117	WITH CONSULT-II	140
WITH GST	117	WITH GST	140
Diagnostic Procedure	118	Wiring Diagram — CVT — PRIPS	141
DTC P0778 PRESSURE CONTROL SOLENOID B ELECTRICAL (SEC PRESSURE SOLENOID VALVE) 120		Diagnostic Procedure	142
Description	120	DTC P0868 SECONDARY PRESSURE DOWN 145	
CONSULT-II Reference Value	120	Description	145
		CONSULT-II Reference Value	145
		On Board Diagnosis Logic	145
		Possible Cause	145
		DTC Confirmation Procedure	145

A
B
CVT
D
E
F
G
H
I
J
K
L
M

WITH CONSULT-II	145	Possible Cause	168
Diagnostic Procedure	146	DTC Confirmation Procedure	168
DTC P1701 TRANSMISSION CONTROL MODULE		WITH CONSULT-II	168
(POWER SUPPLY)	148	Diagnostic Procedure	168
Description	148	DTC P1777 STEP MOTOR - CIRCUIT	169
On Board Diagnosis Logic	148	Description	169
Possible Cause	148	CONSULT-II Reference Value	169
DTC Confirmation Procedure	148	On Board Diagnosis Logic	169
WITH CONSULT-II	148	Possible Cause	169
Wiring Diagram — CVT — POWER (LHD Models)	149	DTC Confirmation Procedure	169
Wiring Diagram — CVT — POWER (RHD Models)	151	WITH CONSULT-II	169
Diagnostic Procedure	152	WITH GST	169
DTC P1705 THROTTLE POSITION SENSOR	155	Wiring Diagram — CVT — STM	170
Description	155	Diagnostic Procedure	171
CONSULT-II Reference Value	155	Component Inspection	172
On Board Diagnosis Logic	155	STEP MOTOR	172
Possible Cause	155	DTC P1778 STEP MOTOR - FUNCTION	173
DTC Confirmation Procedure	155	Description	173
WITH CONSULT-II	155	CONSULT-II Reference Value	173
Diagnostic Procedure	156	On Board Diagnosis Logic	173
DTC P1722 ESTM VEHICLE SPEED SIGNAL	157	Possible Cause	173
Description	157	DTC Confirmation Procedure	173
CONSULT-II Reference Value	157	WITH CONSULT-II	173
On Board Diagnosis Logic	157	WITH GST	174
Possible Cause	157	Diagnostic Procedure	174
DTC Confirmation Procedure	157	CVT INDICATOR CIRCUIT	175
WITH CONSULT-II	157	Description	175
Diagnostic Procedure	158	CONSULT-II Reference Value	175
DTC P1723 CVT SPEED SENSOR FUNCTION	159	Diagnostic Procedure	175
Description	159	CVT INDICATOR SYMPTOM CHART	175
On Board Diagnosis Logic	159	TROUBLE DIAGNOSIS FOR SYMPTOMS	176
Possible Cause	159	Wiring Diagram — CVT — NONDTC (LHD Models)	176
DTC Confirmation Procedure	159	Wiring Diagram — CVT — NONDTC (RHD Models)	180
WITH CONSULT-II	159	CVT Indicator Lamp Does Not Come On	184
Diagnostic Procedure	160	SYMPTOM:	184
DTC P1726 ELECTRIC THROTTLE CONTROL		DIAGNOSTIC PROCEDURE	184
SYSTEM	161	Engine Cannot Be Started in “P” or “N” Position	186
Description	161	SYMPTOM:	186
On Board Diagnosis Logic	161	DIAGNOSTIC PROCEDURE	186
Possible Cause	161	In “P” Position, Vehicle Moves Forward or Backward	
DTC Confirmation Procedure	161	When Pushed	187
WITH CONSULT-II	161	SYMPTOM:	187
Diagnostic Procedure	162	DIAGNOSTIC PROCEDURE	187
DTC P1740 LOCK-UP SELECT SOLENOID VALVE		In “N” Position, Vehicle Moves	188
CIRCUIT	163	SYMPTOM:	188
Description	163	DIAGNOSTIC PROCEDURE	188
CONSULT-II Reference Value	163	Large Shock “N” → “R” Position	189
On Board Diagnosis Logic	163	SYMPTOM:	189
Possible Cause	163	DIAGNOSTIC PROCEDURE	189
DTC Confirmation Procedure	163	Vehicle Does Not Creep Backward in “R” Position	191
WITH CONSULT-II	163	SYMPTOM:	191
WITH GST	163	DIAGNOSTIC PROCEDURE	191
Wiring Diagram — CVT — L/USSV	164	Vehicle Does Not Creep Forward in “D” Position	193
Diagnostic Procedure	165	SYMPTOM:	193
Component Inspection	167	DIAGNOSTIC PROCEDURE	193
LOCK-UP SELECT SOLENOID VALVE	167	CVT Does Not Shift	195
DTC P1745 LINE PRESSURE CONTROL	168	SYMPTOM:	195
Description	168	DIAGNOSTIC PROCEDURE	195
On Board Diagnosis Logic	168	Cannot Be Changed to Manual Mode	197

SYMPTOM:	197	DIFFERENTIAL SIDE OIL SEAL	215	
DIAGNOSTIC PROCEDURE	197	Removal and Installation	215	A
CVT Does Not Shift in Manual Mode	198	COMPONENTS	215	
SYMPTOM:	198	REMOVAL	215	B
DIAGNOSTIC PROCEDURE	198	INSTALLATION	216	
Vehicle Does Not Decelerate by Engine Brake ...	200	CVT FLUID COOLER SYSTEM	217	
SYMPTOM:	200	CVT Fluid Cooler Removal and Installation	217	
DIAGNOSTIC PROCEDURE	200	COMPONENTS	217	CVT
SHIFT CONTROL SYSTEM	202	REMOVAL	217	
Removal and Installation	202	INSTALLATION	219	
CONTROL DEVICE COMPONENTS	202	CVT Fluid Cooler Bypass Valve Removal and Instal-		
CONTROL CABLE COMPONENTS	203	lation	220	D
REMOVAL	203	REMOVAL	220	
INSTALLATION	204	INSTALLATION	221	
Adjustment of CVT Position	204	CVT Fluid Cooler Valve Removal and Installation	222	E
Checking of CVT Position	205	COMPONENTS	222	
CVT SHIFT LOCK SYSTEM	206	REMOVAL	223	
Description	206	INSTALLATION	225	F
Shift Lock System Electrical Parts Location	206	COMPONENT INSPECTION	225	
Wiring Diagram — CVT — SHIFT (LHD Models)	207	TRANSAXLE ASSEMBLY	226	
Wiring Diagram — CVT — SHIFT (RHD Models)	209	Removal and Installation	226	
Shift Lock Control Unit Reference Values	211	COMPONENTS	226	G
SHIFT LOCK HARNESS CONNECTOR TERMINALS LAYOUT	211	REMOVAL	227	
SHIFT LOCK CONTROL UNIT INSPECTION TABLE	211	INSPECTION	229	
Component Inspection	212	INSTALLATION	230	H
SHIFT LOCK SOLENOID	212	SERVICE DATA AND SPECIFICATIONS (SDS) ...	232	
DETENTION SWITCH	212	General Specifications	232	
DETENTION SWITCH	212	Vehicle Speed at Which Gear Shifting Occurs	232	I
KEY LOCK SOLENOID	212	Stall Speed	232	
KEY SWITCH	213	Line Pressure	232	J
STOP LAMP SWITCH	213	Solenoid Valves	232	
AIR BREATHER HOSE	214	CVT Fluid Temperature Sensor	233	
Removal and Installation	214	Primary Speed Sensor	233	K
		Secondary Speed Sensor	233	
		Removal and Installation	233	L
				M

INDEX FOR DTC

INDEX FOR DTC

PFP:00024

Alphabetical Index

ECS00F56

NOTE:

If DTC “U1000 CAN COMM CIRCUIT” is displayed with other DTCs, first perform the trouble diagnosis for “DTC U1000 CAN COMMUNICATION LINE”. Refer to [CVT-65](#) .

Items (CONSULT-II screen terms)	DTC		Reference page
	OBD-II	Except OBD-II	
	CONSULT-II GST*1	CONSULT-II only “TRANSMISSION”	
A/T TCC S/V FNCTN	P0744	P0744	CVT-106
ATF TEMP SEN/CIRC	P0710	P0710	CVT-81
BELT DAMG	—	P0730	CVT-99
BRAKE SW/CIRC	—	P0703	CVT-72
CAN COMM CIRCUIT	U1000	U1000	CVT-65
CVT SPD SEN/FNCTN	—	P1723	CVT-159
ENGINE SPEED SIG	—	P0725	CVT-97
ELEC TH CONTROL	—	P1726	CVT-161
ESTM VEH SPD SIG	—	P1722	CVT-157
INPUT SPD SEN/CIRC	P0715	P0715	CVT-86
L/PRESS CONTROL	—	P1745	CVT-168
L/PRESS SOL/CIRC	P0745	P0745	CVT-109
LU-SLCT SOL/CIRC	P1740	P1740	CVT-163
MANUAL MODE SWITCH	—	P0826	CVT-125
PNP SW/CIRC	P0705	P0705	CVT-74
PRESS SEN/FNCTN	—	P0841	CVT-137
PRS CNT SOL/A FCTN	P0746	P0746	CVT-114
PRS CNT SOL/B CIRC	P0778	P0778	CVT-120
PRS CNT SOL/B FCTN	P0776	P0776	CVT-117
SEC/PRESS DOWN	—	P0868	CVT-145
STARTER RELAY/CIRC	—	P0615	CVT-68
STEP MOTR CIRC	P1777	P1777	CVT-169
STEP MOTR/FNC	P1778	P1778	CVT-173
TCC SOLENOID/CIRC	P0740	P0740	CVT-101
TCM-POWER SUPPLY	—	P1701	CVT-148
TP SEN/CIRC A/T	—	P1705	CVT-155
TR PRS SENS/A CIRC	P0840	P0840	CVT-132
TR PRS SENS/B CIRC	P0845	P0845	CVT-140
VEH SPD SEN/CIR AT	P0720	P0720	CVT-91

*1: These numbers are prescribed by SAE J2012.

INDEX FOR DTC

DTC No. Index

ECS00F57

NOTE:

If DTC "U1000 CAN COMM CIRCUIT" is displayed with other DTCs, first perform the trouble diagnosis for "DTC U1000 CAN COMMUNICATION LINE". Refer to [CVT-65](#).

DTC		Items (CONSULT-II screen terms)	Reference page
OBD-II	Except OBD-II		
CONSULT-II GST*1	CONSULT-II only "TRANSMISSION"		
—	P0615	STARTER RELAY/CIRC	CVT-68
—	P0703	BRAKE SW/CIRC	CVT-72
P0705	P0705	PNP SW/CIRC	CVT-74
P0710	P0710	ATF TEMP SEN/CIRC	CVT-81
P0715	P0715	INPUT SPD SEN/CIRC	CVT-86
P0720	P0720	VEH SPD SEN/CIR AT	CVT-91
—	P0725	ENGINE SPEED SIG	CVT-97
—	P0730	BELT DAMG	CVT-99
P0740	P0740	TCC SOLENOID/CIRC	CVT-101
P0744	P0744	A/T TCC S/V FNCTN	CVT-106
P0745	P0745	L/PRESS SOL/CIRC	CVT-109
P0746	P0746	PRS CNT SOL/A FCTN	CVT-114
P0776	P0776	PRS CNT SOL/B FCTN	CVT-117
P0778	P0778	PRS CNT SOL/B CIRC	CVT-120
—	P0826	MANUAL MODE SWITCH	CVT-125
P0840	P0840	TR PRS SENS/A CIRC	CVT-132
—	P0841	PRESS SEN/FNCTN	CVT-137
P0845	P0845	TR PRS SENS/B CIRC	CVT-140
—	P0868	SEC/PRESS DOWN	CVT-145
—	P1701	TCM-POWER SUPPLY	CVT-148
—	P1705	TP SEN/CIRC A/T	CVT-155
—	P1722	ESTM VEH SPD SIG	CVT-157
—	P1723	CVT SPD SEN/FNCTN	CVT-159
—	P1726	ELEC TH CONTROL	CVT-161
P1740	P1740	LU-SLCT SOL/CIRC	CVT-163
—	P1745	L/PRESS CONTROL	CVT-168
P1777	P1777	STEP MOTR CIRC	CVT-169
P1778	P1778	STEP MOTR/FNC	CVT-173
U1000	U1000	CAN COMM CIRCUIT	CVT-65

*1: These numbers are prescribed by SAE J2012.

PRECAUTIONS

PRECAUTIONS

PFP:00001

Precautions for Supplemental Restraint System (SRS) “AIR BAG” and “SEAT BELT PRE-TENSIONER”

ECS00F58

The Supplemental Restraint System such as “AIR BAG” and “SEAT BELT PRE-TENSIONER”, used along with a front seat belt, helps to reduce the risk or severity of injury to the driver and front passenger for certain types of collision. This system includes seat belt switch inputs and dual stage front air bag modules. The SRS system uses the seat belt switches to determine the front air bag deployment, and may only deploy one front air bag, depending on the severity of a collision and whether the front occupants are belted or unbelted. Information necessary to service the system safely is included in the SRS and SB section of this Service Manual.

WARNING:

- To avoid rendering the SRS inoperative, which could increase the risk of personal injury or death in the event of a collision which would result in air bag inflation, all maintenance must be performed by an authorized NISSAN/INFINITI dealer.
- Improper maintenance, including incorrect removal and installation of the SRS, can lead to personal injury caused by unintentional activation of the system. For removal of Spiral Cable and Air Bag Module, see the SRS section.
- Do not use electrical test equipment on any circuit related to the SRS unless instructed to in this Service Manual. SRS wiring harnesses can be identified by yellow and/or orange harnesses or harness connectors.

On Board Diagnostic (OBD) System of CVT and Engine

ECS00FNP

The ECM has an on board diagnostic system. It will light up the malfunction indicator (MI) to warn the driver of a malfunction causing emission deterioration.

CAUTION:

- Be sure to turn the ignition switch OFF and disconnect the negative battery cable before any repair or inspection work. The open/short circuit of related switches, sensors, solenoid valves, etc. will cause the MI to light up.
- Be sure to connect and lock the connectors securely after work. A loose (unlocked) connector will cause the MI to light up due to the open circuit. (Be sure the connector is free from water, grease, dirt, bent terminals, etc.)
- Be sure to route and secure the harnesses properly after work. The interference of the harness with a bracket, etc. may cause the MI to light up due to the short circuit.
- Be sure to connect rubber tubes properly after work. A misconnected or disconnected rubber tube may cause the MI to light up due to the malfunction of the fuel injection system, etc.
- Be sure to erase the unnecessary malfunction information (repairs completed) from the TCM and ECM before returning the vehicle to the customer.

Precautions for TCM and CVT Assembly Replacement

ECS00F5A

CAUTION:

- Check if new data (Unit ID) are entered correctly after replacing CVT assembly and erasing data in TCM. (Connect CONSULT-II, and then turn ignition switch OFF.)
- When replacing CVT assembly or TCM, refer to the pattern table below and erase the EEPROM in the TCM if necessary.

EEPROM ERASING PATTERNS

CVT assembly	TCM	Erasing EEPROM in TCM	Remarks
Replaced	Replaced	Not required	Not required because the EEPROM in the TCM is in the default state. (CVT assembly must be replaced first.)
Not replaced	Replaced	Not required	Not required because the EEPROM in the TCM is in the default state.
Replaced	Not replaced	Required	Required because data has been written in the EEPROM in the TCM and because the TCM cannot write data from the ROM assembly in the transmission.

PRECAUTIONS

METHOD FOR ERASING THE EEPROM IN THE TCM

1. Connect CONSULT-II to data link connector. Refer to [CVT-55, "CONSULT-II SETTING PROCEDURE"](#) .
2. Turn ignition switch ON. Confirm that CONSULT-II is turned ON.
3. Move selector lever to "R" position.
4. Touch "START (NISSAN BASED VHCL)" on CONSULT-II.
5. Select "SELF-DIAG RESULTS" mode for "TRANSMISSION" with CONSULT-II.
6. Press the brake pedal and turn the brake switch ON.
7. Press the accelerator pedal (0.5/8 - 4/8 throttle) not to exceed the half, and hold it in the half or less open position. (This will set the closed throttle position signal to OFF and the wide open throttle position signal to "OFF".)
8. Touch "ERASE" on CONSULT-II, and then touch "YES".
9. Wait 3 seconds and then release the accelerator pedal.
10. Turn ignition switch OFF.

METHOD FOR WRITING DATA FROM THE ROM ASSEMBLY IN THE TRANSAXLE

In the following procedure, the TCM reads data from the ROM assembly and writes it to the EEPROM in the TCM.

1. Erase the EEPROM in the TCM.
2. Move selector lever to "P" position.
3. Turn ignition switch ON.

CHECK METHOD

- Standard: About 2 seconds after the ignition switch ON, the CVT indicator lamp lights up for 2 seconds.
- Non-standard: Even after the ignition switch ON, the CVT indicator lamp does not light up after 2 seconds or illuminates immediately.

CAUTION:

Perform in the "P" or "N" position.

Action for Non-standard

- Replace the CVT assembly.
- Replace the TCM.

Removal and Installation Procedure for CVT Unit Connector

REMOVAL

- Rotate bayonet ring counterclockwise, pull out CVT unit harness connector upward and remove it.

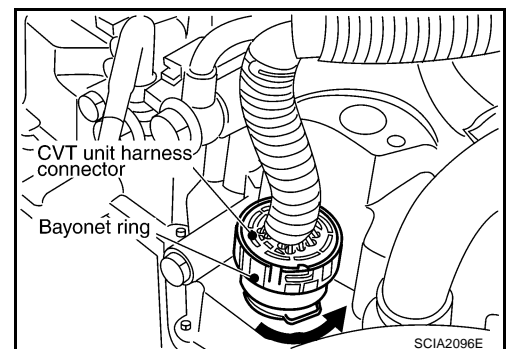

PRECAUTIONS

INSTALLATION

1. Align Δ marking on CVT unit harness connector terminal body with \square marking on bayonet ring, insert CVT unit harness connector, and then rotate bayonet ring clockwise.

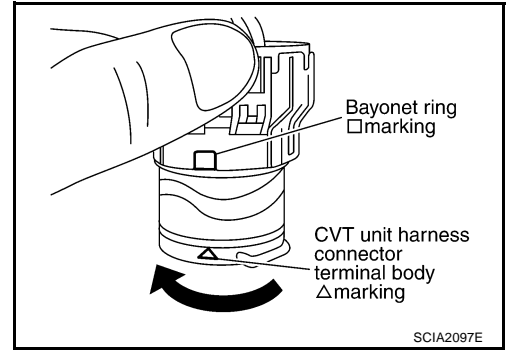

2. Rotate bayonet ring clockwise until Δ marking on CVT unit harness connector terminal body is aligned with the slit on bayonet ring as shown in the figure (correctly fitting condition), install CVT unit harness connector to CVT unit harness connector terminal body.

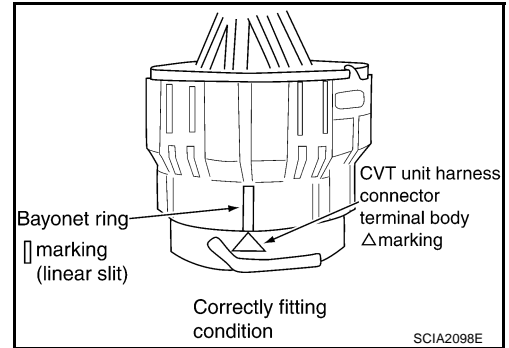

CAUTION:

- Securely align Δ marking on CVT unit harness connector terminal body with bayonet ring slit. Then, be careful not to make a half fit condition as shown in the figure.
- Do not mistake the slit of bayonet ring for other dent portion.

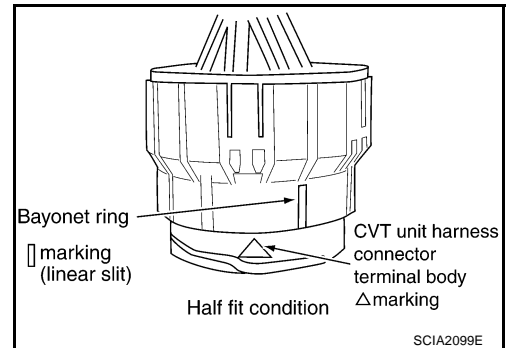

Precautions

ECS00F5C

NOTE:

If any malfunction occurs in the RE0F09A model transaxle, replace the entire transaxle assembly.

- Before connecting or disconnecting the TCM harness connector, turn ignition switch OFF and disconnect the battery cable from the negative terminal. Because battery voltage is applied to TCM even if ignition switch is turned OFF.

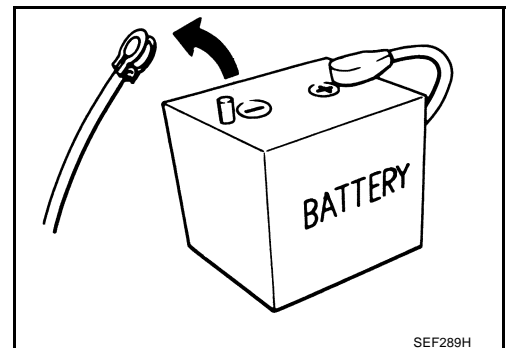

PRECAUTIONS

- When connecting or disconnecting pin connectors into or from TCM, take care not to damage pin terminals (bend or break).
When connecting pin connectors make sure that there are not any bends or breaks on TCM pin terminal.

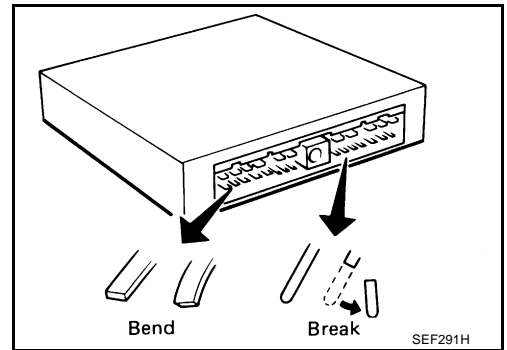

- Before replacing TCM, perform TCM input/output signal inspection and make sure whether TCM functions properly or not. Refer to [CVT-50, "TCM INSPECTION TABLE"](#).

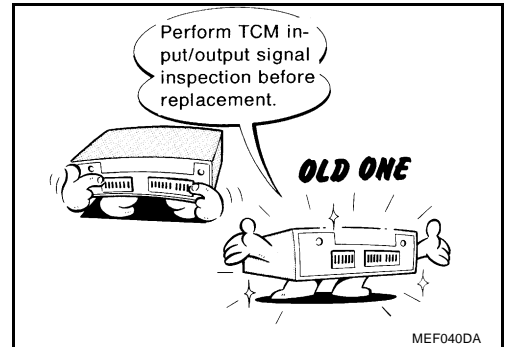

- After performing each TROUBLE DIAGNOSIS, perform "DTC Confirmation Procedure".
If the repair is completed the DTC should not be displayed in the "DTC Confirmation Procedure".
- Always use the specified brand of CVT fluid. Refer to [MA-14, "Fluids and Lubricants"](#).
- Use lint-free paper, not cloth rags, during work.
- After replacing the CVT fluid, dispose of the waste oil using the methods prescribed by law, ordinance, etc.

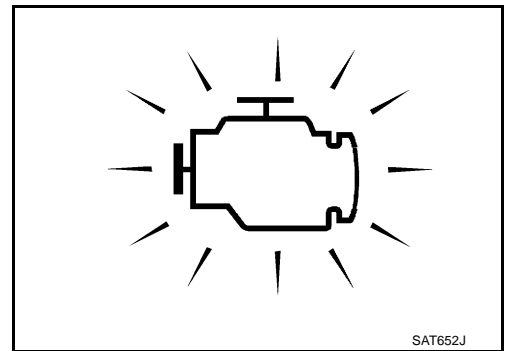

Service Notice or Precautions OBD-II SELF-DIAGNOSIS

- CVT self-diagnosis is performed by the TCM in combination with the ECM. The results can be read through the blinking pattern of the malfunction indicator (MI). Refer to the table on [CVT-58, "Display Items List"](#) for the indicator used to display each self-diagnostic result.
- The self-diagnostic results indicated by the MI are automatically stored in both the TCM and ECM memories.
Always perform the procedure on [CVT-26, "HOW TO ERASE DTC"](#) to complete the repair and avoid unnecessary blinking of the MI.

For details of OBD-II, refer to [EC-35, "ON BOARD DIAGNOSTIC \(OBD\) SYSTEM"](#).

- Certain systems and components, especially those related to OBD, may use the new style slide-locking type harness connector. For description and how to disconnect, refer to [PG-103, "HARNESS CONNECTOR"](#).

Wiring Diagrams and Trouble Diagnosis

When reading wiring diagrams, refer to the following:

- [GI-14, "How to Read Wiring Diagrams"](#).
- [PG-3, "POWER SUPPLY ROUTING CIRCUIT"](#) for power distribution circuit.

When performing trouble diagnosis, refer to the following:

- [GI-10, "How to Follow Trouble Diagnoses"](#).
- [GI-23, "How to Perform Efficient Diagnosis for an Electrical Incident"](#).

A
B
CVT
D
E
F
G
H
I
J
K
L
M

PREPARATION

PREPARATION

PFP:00002

Special Service Tools

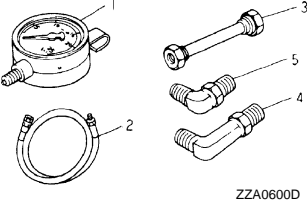
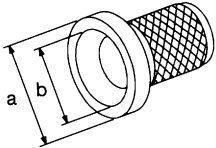
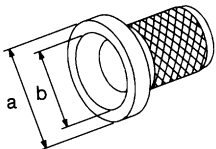

ECS00F5F

Tool number Tool name	Description
<p>ST2505S001 Oil pressure gauge set 1 ST25051001 Oil pressure gauge 2 ST25052000 Hose 3 ST25053000 Joint pipe 4 ST25054000 Adapter 5 ST25055000 Adapter</p>	<p>Measuring line pressure</p>  <p style="text-align: right;">ZZA0600D</p>
<p>KV40100621 Drift a: 76 mm (2.99 in) dia. b: 69 mm (2.72 in) dia</p>	<p>Installing differential side oil seal</p> <ul style="list-style-type: none"> ● Converter housing side (right)  <p style="text-align: center;">NT086</p>
<p>ST33400001 Drift a: 60 mm (2.36 in) dia. b: 47 mm (1.85 in) dia.</p>	<p>Installing differential side oil seal</p> <ul style="list-style-type: none"> ● Transaxle case side (left)  <p style="text-align: center;">NT086</p>

PREPARATION

Commercial Service Tools

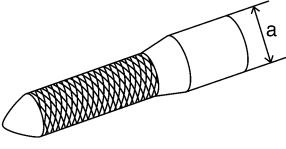
ECS00F5G

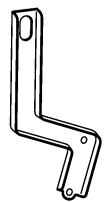
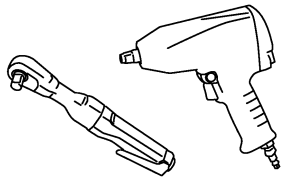
Tool number Tool name	Description
31197CA000 Drive plate location guide a: 14 mm (0.55 in) dia. <div style="text-align: center;">  <p>SCIA2013E</p> </div>	Installing transaxle assembly
31093CA000 Slinger <div style="text-align: center;">  <p>SCIA2014E</p> </div>	Removing and installing transaxle assembly
31092CA000 Slinger <div style="text-align: center;">  <p>SCIA2015E</p> </div>	Removing and installing transaxle assembly
Power tool <div style="text-align: center;">  <p>PBIC0190E</p> </div>	Loosening nuts and bolts

A
B
CVT
D
E
F
G
H
I
J
K
L
M

CVT FLUID

PFP:KLE50

Checking CVT Fluid

ECS00F5H

Fluid level should be checked with the fluid warmed up to 50 to 80°C (122 to 176°F). The fluid level check procedure is as follows:

1. Check for fluid leakage.
2. With the engine warmed up, drive the vehicle in an urban area. When ambient temperature is 20°C (68°F), it takes about 10 minutes for the CVT fluid to warm up to 50 to 80°C (122 to 176°F).
3. Park the vehicle on a level surface.
4. Apply parking brake firmly.
5. With engine at idle, while depressing brake pedal, move shift selector throughout the entire shift range.

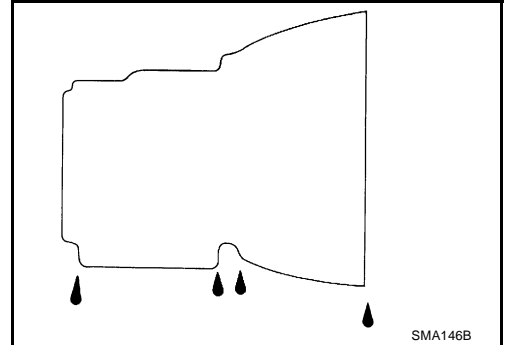

6. Pull out the CVT fluid level gauge from the CVT fluid charging pipe after pressing the tab on the CVT fluid level gauge to release the lock.

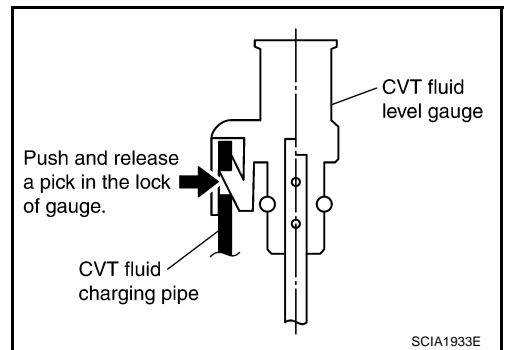

7. Wipe fluid off the CVT fluid level gauge. Insert the CVT fluid level gauge rotating 180° from the originally installed position, then securely push the CVT fluid level gauge until it meets the top end of the CVT fluid charging pipe.

CAUTION:

When wiping away the CVT fluid level gauge, always use lint-free paper, not a cloth rag.

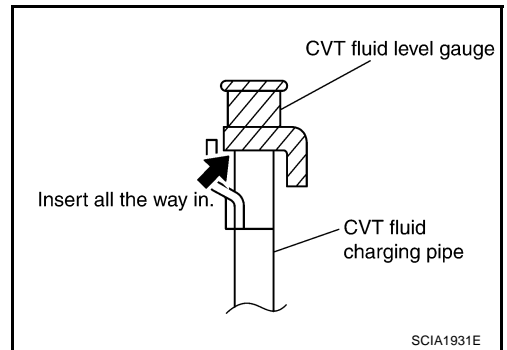

8. Place the selector lever in "P" or "N" and make sure the fluid level is within the specified range.

CAUTION:

- **When reinstalling CVT fluid level gauge, insert it into the CVT fluid charging pipe and rotate it to the original installation position until it is securely locked.**

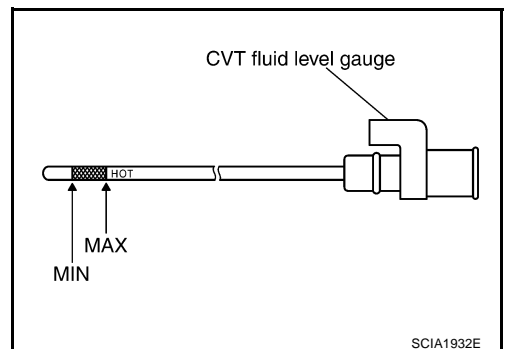

CVT FLUID

9. Check CVT fluid condition.

- If CVT fluid is very dark or smells burned, check operation of CVT. Flush cooling system after repair of CVT.
- If CVT fluid contains frictional material (clutches, bands, etc.), replace radiator and flush cooler line using cleaning solvent and compressed air after repair of CVT. Refer to [CO-13, "RADIATOR"](#).

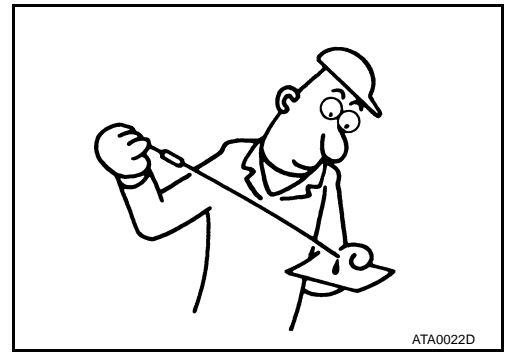

ATA0022D

ECS00F5I

Changing CVT Fluid

1. Warm up CVT fluid by driving the vehicle for 10 minutes.
 - ←: Vehicle front
 - Radiator (2)
 - CVT fluid cooler hose [inlet side (3)]
 - Transaxle assembly (4)
2. Drain CVT fluid from CVT fluid cooler hose [outlet side (1)] and refill with new CVT fluid at CVT fluid charging pipe with the engine running at idle speed.
3. Refill until new CVT fluid comes out from CVT fluid cooler hose (outlet side).
About 30 to 50% extra fluid will be required for this procedure.

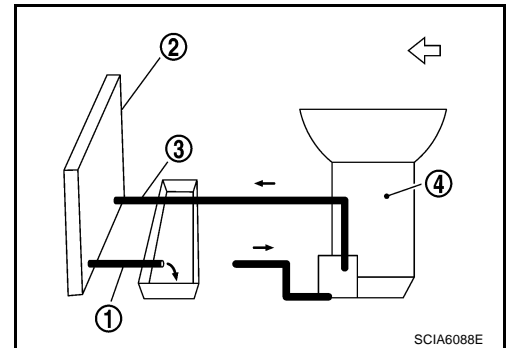

SCIA6088E

CVT fluid:

Genuine NISSAN CVT fluid NS-2

Fluid capacity:

Approx. 10.0 ℓ (8-3/4 Imp qt)

CAUTION:

- Use only Genuine NISSAN CVT fluid NS-2. Do not mix with other fluid.
 - Using CVT fluid other than Genuine NISSAN CVT fluid NS-2 will deteriorate in driveability and CVT durability, and may damage the CVT, which is not covered by the warranty.
 - When filling CVT fluid, take care not to scatter heat generating parts such as exhaust.
 - Delete CVT fluid deterioration date with CONSULT-II after changing CVT fluid. Refer to [CVT-57, "Check CVT Fluid Deterioration Date"](#).
4. Check fluid leakage, fluid level and condition.

CVT SYSTEM

PFP:31036

CVT SYSTEM

Cross-Sectional View - RE0F09A

ECS00F5K

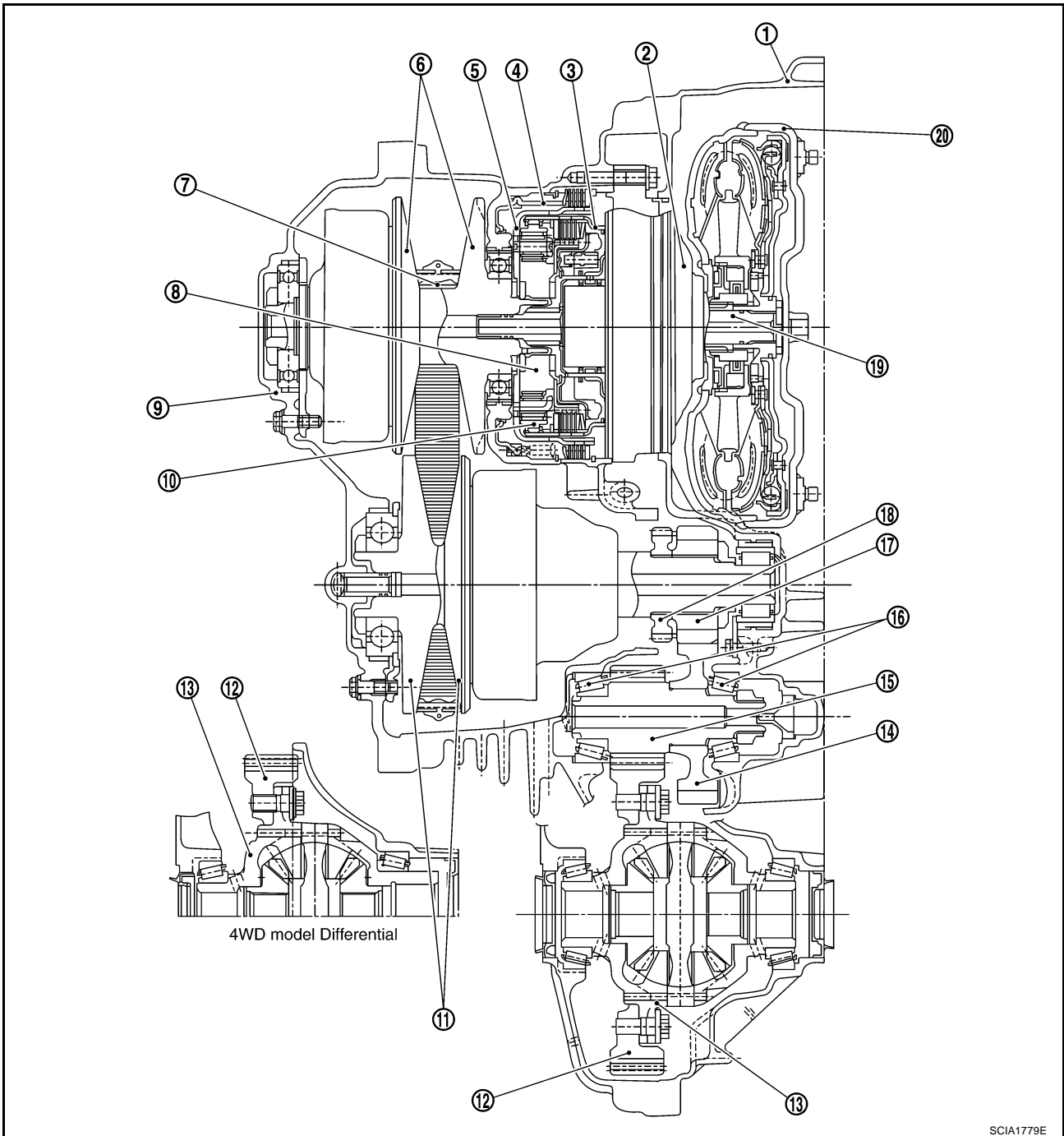

SCIA1779E

- | | | |
|--------------------------|----------------------|--------------------|
| 1. Converter housing | 2. Oil pump | 3. Forward clutch |
| 4. Reverse brake | 5. Planetary carrier | 6. Primary pulley |
| 7. Steel belt | 8. Sun gear | 9. Side cover |
| 10. Internal gear | 11. Secondary pulley | 12. Final gear |
| 13. Differential case | 14. Idler gear | 15. Reduction gear |
| 16. Taper roller bearing | 17. Output gear | 18. Parking gear |
| 19. Input shaft | 20. Torque converter | |

CVT SYSTEM

Control System

ECS00F5L

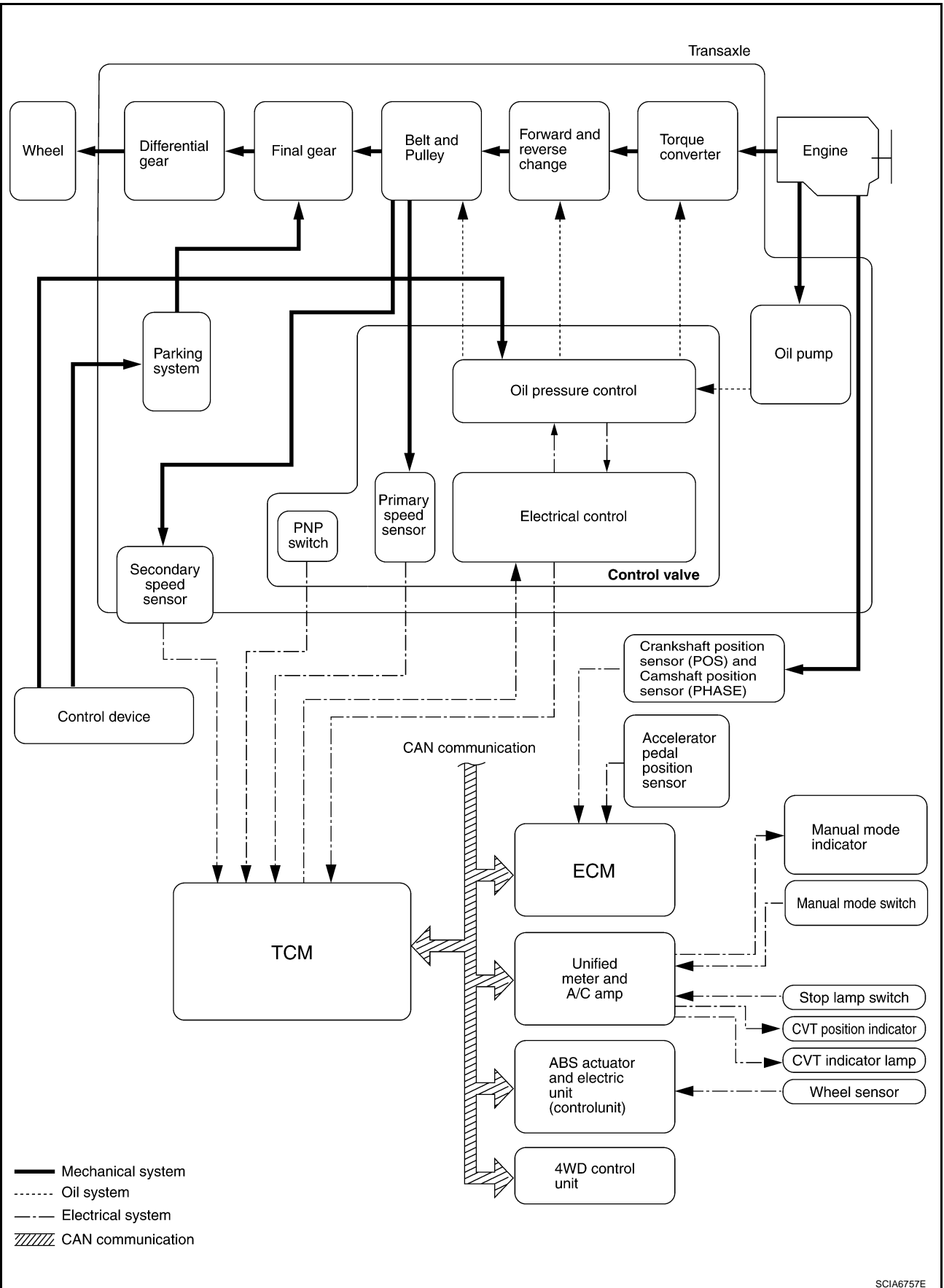

A
B
CVT
D
E
F
G
H
I
J
K
L
M

SCIA6757E

CVT SYSTEM

Hydraulic Control System

ECS00F5M

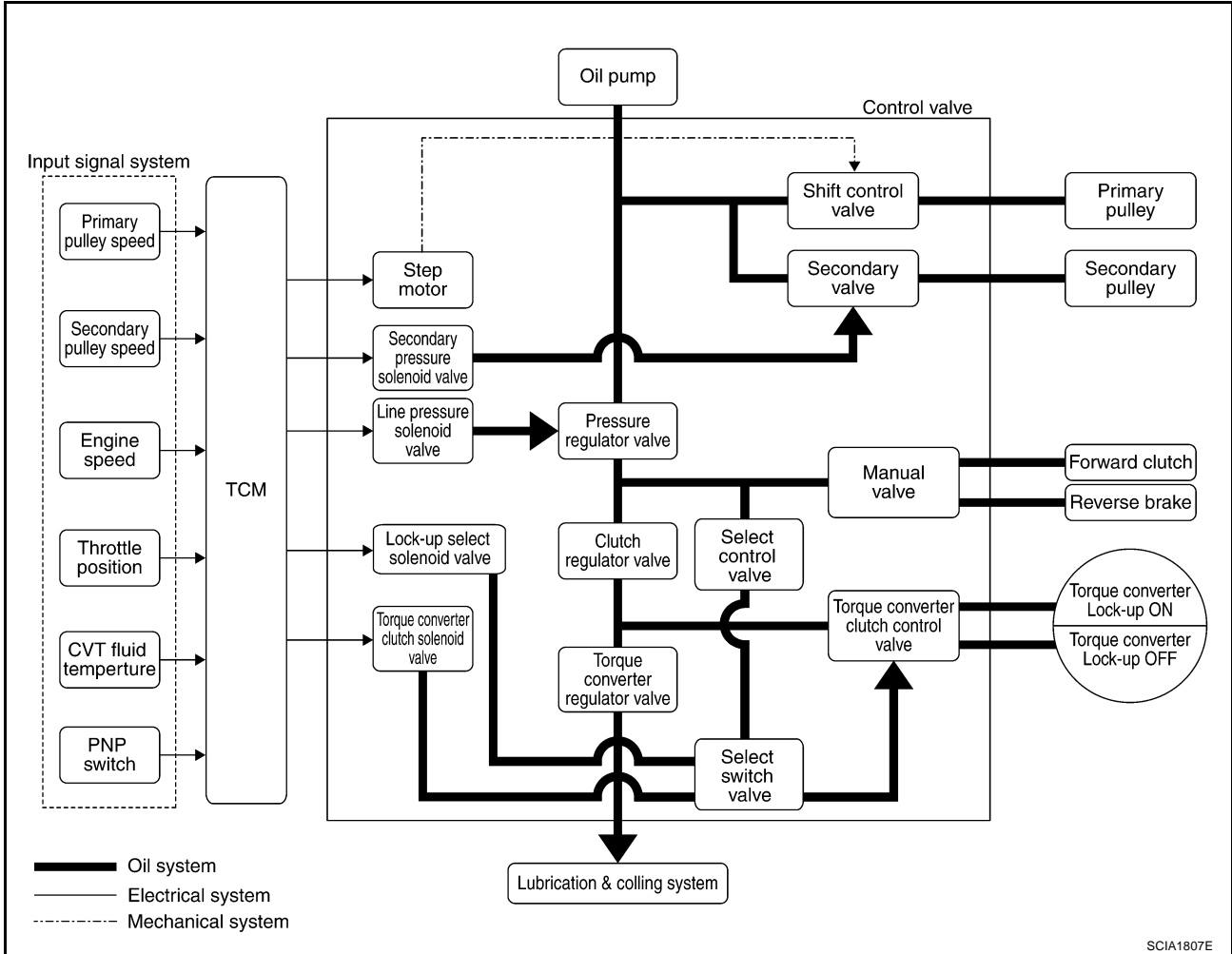

CVT SYSTEM

EC.S00F5N

TCM Function

The function of the TCM is to:

- Receive input signals sent from various switches and sensors.
- Determine required line pressure, shifting point, and lock-up operation.
- Send required output signals to the step motor and the respective solenoids.

CONTROL SYSTEM OUTLINE

The CVT senses vehicle operating conditions through various sensors. It always controls the optimum shift position and reduces shifting and lock-up shocks.

SENSORS (or SIGNAL)	TCM	ACTUATORS
PNP switch Accelerator pedal position signal Closed throttle position signal Engine speed signal CVT fluid temperature sensor Vehicle speed signal Manual mode signal Stop lamp switch signal Primary speed sensor Secondary speed sensor Primary pressure sensor Secondary pressure sensor	Shift control Line pressure control Primary pressure control Secondary pressure control Lock-up control Engine brake control Vehicle speed control Fail-safe control Self-diagnosis CONSULT-II communication line Duet-EA control CAN system On board diagnosis	Step motor Torque converter clutch solenoid valve Lock-up select solenoid valve Line pressure solenoid valve Secondary pressure solenoid valve Manual mode indicator CVT position indicator CVT indicator lamp Starter relay

CONTROL SYSTEM DIAGRAM

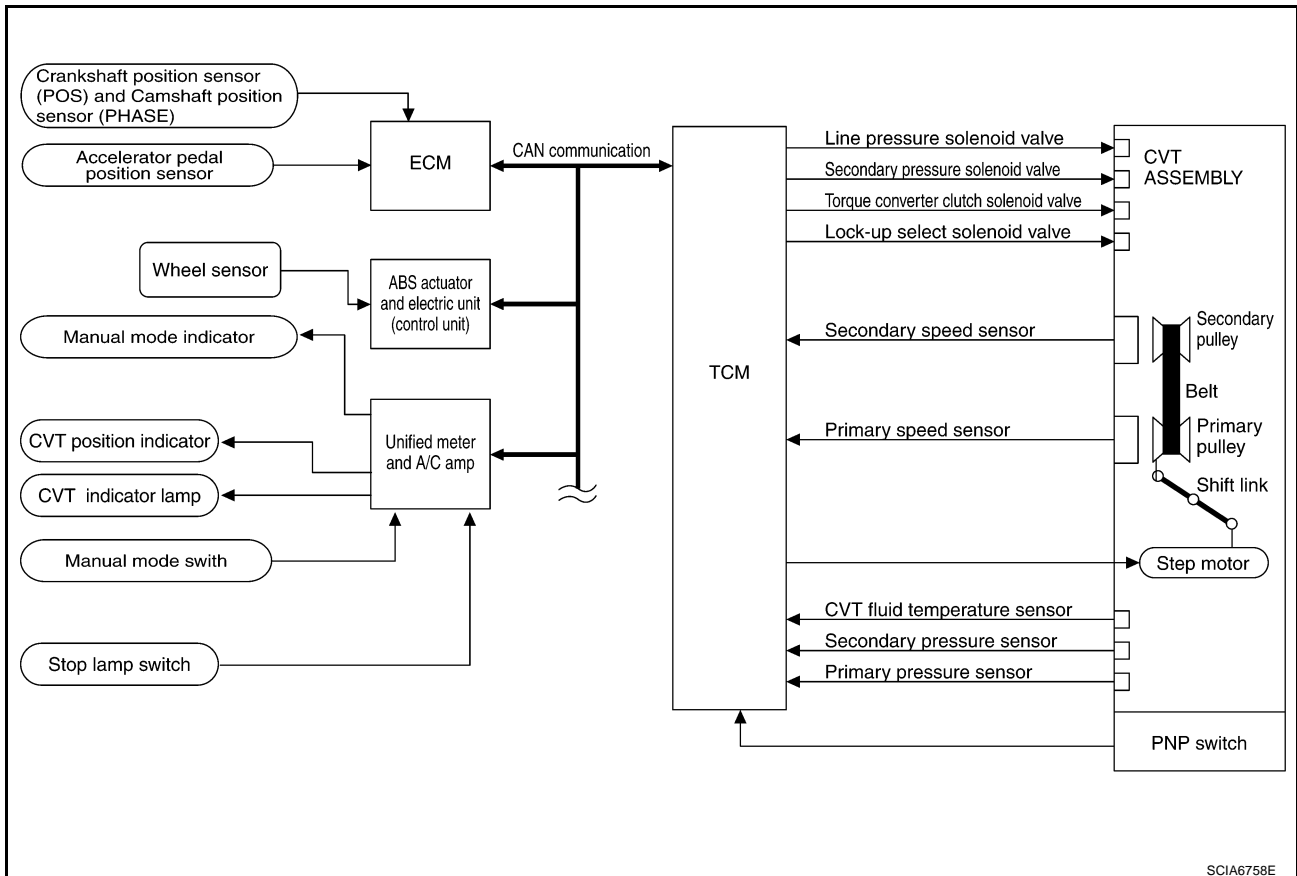

SCIA6758E

CVT SYSTEM

ECS00F50

CAN Communication SYSTEM DESCRIPTION

CAN (Controller Area Network) is a serial communication line for real time application. It is an on-vehicle multiplex communication line with high data communication speed and excellent error detection ability. Many electronic control units are equipped onto a vehicle, and each control unit shares information and links with other control units during operation (not independent). In CAN communication, control units are connected with 2 communication lines (CAN H line, CAN L line) allowing a high rate of information transmission with less wiring. Each control unit transmits/receives data but selectively reads required data only. For details, refer to [LAN-21, "CAN Communication Unit"](#).

Input/Output Signal of TCM

ECS00F5P

Control item		Fluid pressure control	Select control	Shift control	Lock-up control	CAN communication control	Fail-safe function (*2)
Input	PNP switch	X	X	X	X	X	X
	Accelerator pedal position signal (*1)	X	X	X	X	X	X
	Closed throttle position signal(*1)	X		X	X	X	
	Engine speed signal(*1)	X	X		X	X	X
	CVT fluid temperature sensor	X	X	X	X		X
	Manual mode signal(*1)	X		X	X	X	X
	Stop lamp switch signal(*1)	X		X	X	X	
	Primary speed sensor	X		X	X	X	X
	Secondary speed sensor	X	X	X	X	X	X
	Primary pressure sensor	X		X			
	Secondary pressure sensor	X		X			X
	TCM power supply voltage signal	X	X	X	X	X	X
Output	Step motor			X			X
	TCC solenoid valve		X		X		X
	Lock-up select solenoid valve		X		X		X
	Line pressure solenoid valve	X	X	X			X
	Secondary pressure solenoid valve	X		X			X

*1: Input by CAN communications.

*2: If these input and output signals are different, the TCM triggers the fail-safe function.

CVT SYSTEM

Line Pressure and Secondary Pressure Control

ECS00F5Q

- When an input torque signal equivalent to the engine drive force is sent from the ECM to the TCM, the TCM controls the line pressure solenoid valve and secondary pressure solenoid valve.
- This line pressure solenoid controls the pressure regulator valve as the signal pressure and adjusts the pressure of the operating oil discharged from the oil pump to the line pressure most appropriate to the driving state. Secondary pressure is controlled by decreasing line pressure.

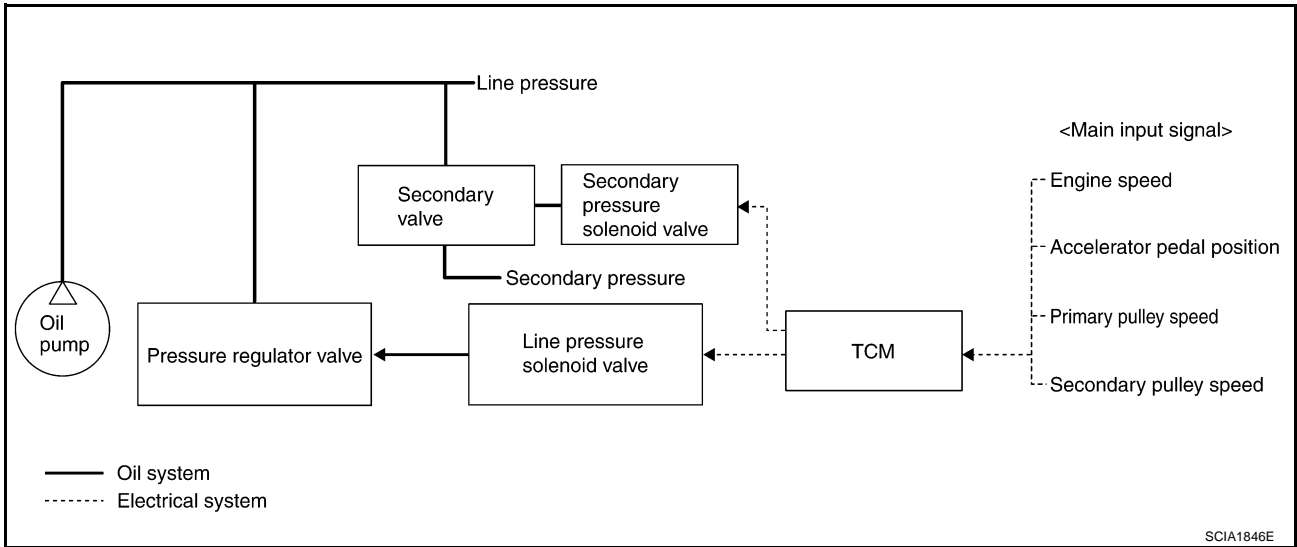

NORMAL CONTROL

Optimize the line pressure and secondary pressure, depending on driving conditions, on the basis of the throttle position, the engine speed, the primary pulley (input) revolution speed, the secondary pulley (output) revolution speed, the brake signal, the PNP switch signal, the lock-up signal, the voltage, the target gear ratio, the fluid temperature, and the fluid pressure.

FEEDBACK CONTROL

When controlling the normal fluid pressure or the selected fluid pressure, the secondary pressure can be set more accurately by using the fluid pressure sensor to detect the secondary pressure and controlling the feedback.

Shift Control

ECS00F5R

In order to select the gear ratio which can obtain the driving force in accordance with driver's intention and the vehicle condition, TCM monitors the driving conditions, such as the vehicle speed and the throttle position and selects the optimum gear ratio, and determines the gear change steps to the gear ratio. Then send the command to the step motor, and control the flow-in/flow-out of line pressure from the primary pulley to determine the position of the moving-pulley and control the gear ratio.

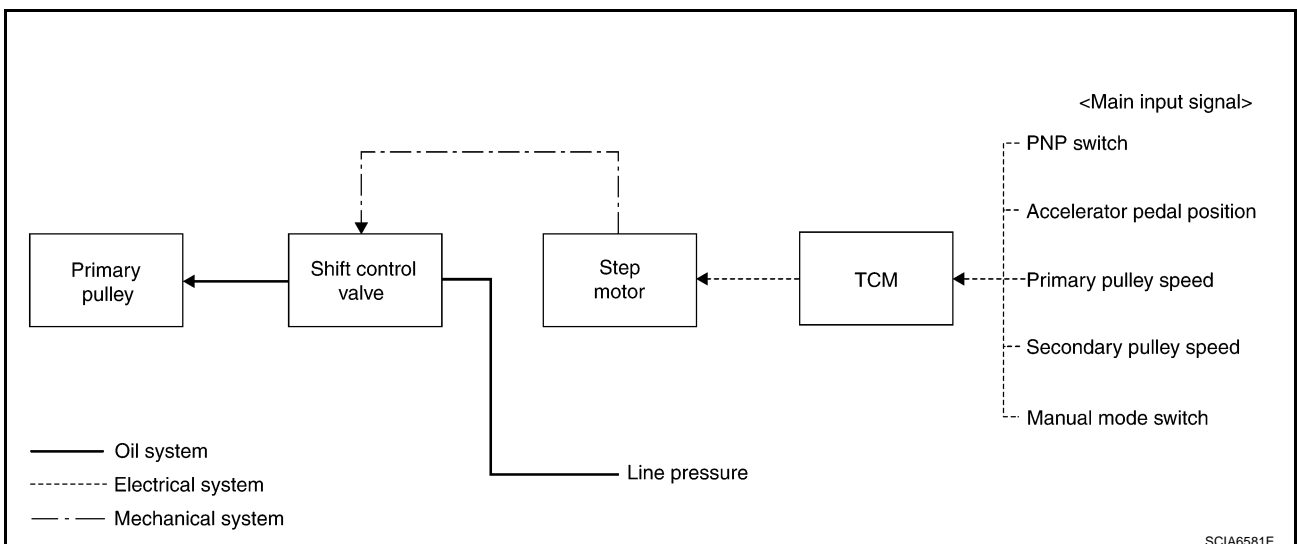

CVT SYSTEM

NOTE:

The gear ratio is set for every position separately.

“D” POSITION

Shifting over all the ranges of gear ratios from the lowest to the highest.

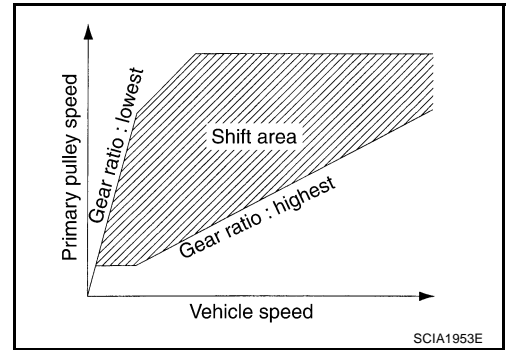

“M” POSITION

When the selector lever is put in the manual shift gate side, the fixed changing gear line is set. By moving the selector lever to + side or - side, the manual mode switch is changed over, and shift change like M/T becomes possible following the changing gear set line step by step.

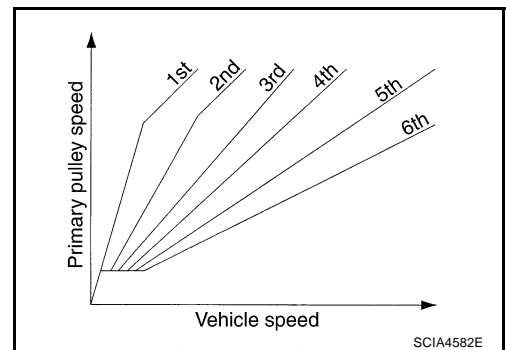

DOWNHILL ENGINE BRAKE CONTROL (AUTO ENGINE BRAKE CONTROL)

When downhill is detected with the accelerator pedal released, the engine brake will be strengthened up by downshifting so as not to accelerate the vehicle more than necessary.

ACCELERATION CONTROL

According to vehicle speed and a change of accelerator pedal angle, driver's request for acceleration and driving scene are judged. This function assists improvement in acceleration feeling by making the engine speed proportionate to the vehicle speed. And a shift map which can gain a larger driving force is available for compatibility of mileage with drivability.

Lock-up and Select Control

ECS00F5S

- The torque converter clutch piston in the torque converter is engaged to eliminate torque converter slip to increase power transmission efficiency.
- The torque converter clutch control valve operation is controlled by the torque converter clutch solenoid valve, which is controlled by a signal from TCM. The torque converter clutch control valve engages or releases the torque converter clutch piston.
- When shifting between “N” (“P”) ↔ “D” (“R”), torque converter clutch solenoid controls engagement power of forward clutch and reverse brake.
- The lock-up applied gear range was expanded by locking up the torque converter at a lower vehicle speed than conventional CVT models.

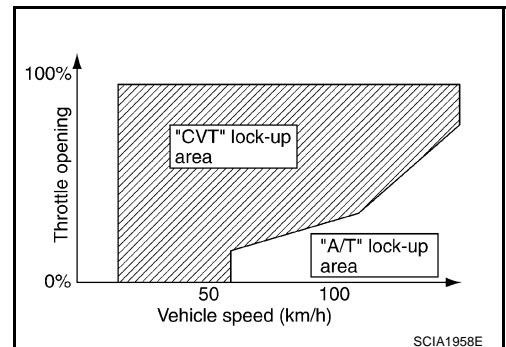

CVT SYSTEM

TORQUE CONVERTER CLUTCH AND SELECT CONTROL VALVE CONTROL

Lock-up and Select Control System Diagram

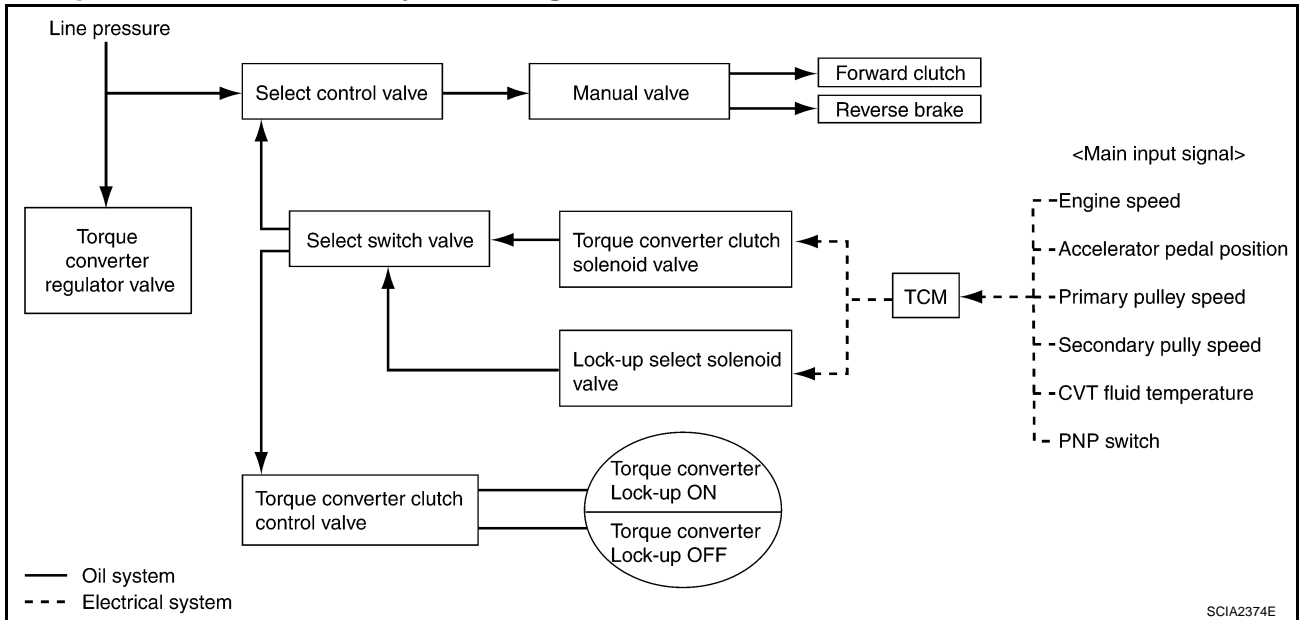

Lock-up Released

- In the lock-up released state, the torque converter clutch control valve is set into the unlocked state by the torque converter clutch solenoid and the lock-up apply pressure is drained. In this way, the torque converter clutch piston is not coupled.

Lock-up Applied

- In the lock-up applied state, the torque converter clutch control valve is set into the locked state by the torque converter clutch solenoid and lock-up apply pressure is generated. In this way, the torque converter clutch piston is pressed and coupled.

Select Control

- When shifting between “N” (“P”) ⇔ “D” (“R”), optimize the operating pressure on the basis of the throttle position, the engine speed, and the secondary pulley (output) revolution speed to lessen the shift shock.

CVT SYSTEM

Control Valve FUNCTION OF CONTROL VALVE

ECS00F5T

Name	Function
Torque converter regulator valve	Optimizes the supply pressure for the torque converter depending on driving conditions.
Pressure regulator valve	Optimizes the discharge pressure from the oil pump depending on driving conditions.
TCC control valve	<ul style="list-style-type: none">● Activates or deactivate the lock-up.● Lock-up smoothly by opening lock-up operation excessively.
TCC solenoid valve	Controls the TCC control valve or select control valve.
Shift control valve	Controls flow-in/out of line pressure from the primary pulley depending on the stroke difference between the stepping motor and the primary pulley.
Secondary valve	Controls the line pressure from the secondary pulley depending on operating conditions.
Clutch regulator valve	Adjusts the clutch operating pressure depending on operating conditions.
Secondary pressure solenoid valve	Controls the secondary valve.
Line pressure solenoid valve	Controls the line pressure control valve.
Step motor	Controls the pulley ratio.
Manual valve	Transmits the clutch operating pressure to each circuit in accordance with the selected position.
Select control valve	Engages forward clutch, reverse brake smoothly depending on select operation.
Select switch valve	Switches torque converter clutch solenoid valve control pressure use to torque converter clutch control valve or select control valve.
Lock-up select solenoid valve	Controls the select switch valve.

ON BOARD DIAGNOSTIC (OBD) SYSTEM

PDF:00028

Introduction

ECS00F5U

The CVT system has two self-diagnostic systems.

The first is the emission-related on board diagnostic system (OBD-II) performed by the TCM in combination with the ECM. The malfunction is indicated by the MI (malfunction indicator) and is stored as a DTC in the ECM memory, and the TCM memory.

The second is the TCM original self-diagnosis performed by the TCM. The malfunction is stored in the TCM memory. The detected items are overlapped with OBD-II self-diagnostic items. For detail, refer to [CVT-58](#), "Display Items List".

OBD-II Function for CVT System

ECS00F5V

The ECM provides emission-related on board diagnostic (OBD-II) functions for the CVT system. One function is to receive a signal from the TCM used with OBD-related parts of the CVT system. The signal is sent to the ECM when a malfunction occurs in the corresponding OBD-related part. The other function is to indicate a diagnostic result by means of the MI (malfunction indicator) on the instrument panel. Sensors, switches and solenoid valves are used as sensing elements.

The MI automatically illuminates in One or Two Trip Detection Logic when a malfunction is sensed in relation to CVT system parts.

One or Two Trip Detection Logic of OBD-II ONE TRIP DETECTION LOGIC

ECS00F5W

If a malfunction is sensed during the first test drive, the MI will illuminate and the malfunction will be stored in the ECM memory as a DTC. The TCM is not provided with such a memory function.

TWO TRIP DETECTION LOGIC

When a malfunction is sensed during the first test drive, it is stored in the ECM memory as a 1st trip DTC (diagnostic trouble code) or 1st trip freeze frame data. At this point, the MI will not illuminate. — 1st trip



If the same malfunction as that experienced during the first test drive is sensed during the second test drive, the MI will illuminate. — 2nd trip

The "trip" in the "One or Two Trip Detection Logic" means a driving mode in which self-diagnosis is performed during vehicle operation.

OBD-II Diagnostic Trouble Code (DTC) HOW TO READ DTC AND 1ST TRIP DTC

ECS00F5X

DTC and 1st trip DTC can be read by the following methods.

( with **CONSULT-II** or ( **GST**) CONSULT-II or GST (Generic Scan Tool) Examples: P0705, P0720 etc. These DTC are prescribed by SAE J2012.

(CONSULT-II also displays the malfunctioning component or system.)

- **1st trip DTC No. is the same as DTC No.**
- **Output of the diagnostic trouble code indicates that the indicated circuit has a malfunction. However, in case of the Mode II and GST, they do not indicate whether the malfunction is still occurring or occurred in the past and returned to normal.**
CONSULT-II can identify them as shown below, therefore, CONSULT-II (if available) is recommended.

A sample of CONSULT-II display for DTC and 1st trip DTC is shown on the next page. DTC or 1st trip DTC of a malfunction is displayed in SELF-DIAGNOSTIC RESULTS mode for "ENGINE" with CONSULT-II. Time data indicates how many times the vehicle was driven after the last detection of a DTC.

SELECT SYSTEM
ENGINE
ABS
AIR BAG
ALL MODE AWD/4WD
IPDM E/R
BCM

SCIA4823E

ON BOARD DIAGNOSTIC (OBD) SYSTEM

If the DTC is being detected currently, the time data will be "0".

SELF-DIAG RESULTS	
DTC RESULTS	TIME
PNP SW/CIRC [P0705]	0

SAT015K

If a 1st trip DTC is stored in the ECM, the time data will be "1 t".

SELF-DIAG RESULTS	
DTC RESULTS	TIME
PNP SW/CIRC [P0705]	1 t

SAT016K

Freeze Frame Data and 1st Trip Freeze Frame Data

The ECM has a memory function, which stores the driving condition such as fuel system status, calculated load value, engine coolant temperature, short term fuel trim, long term fuel trim, engine speed and vehicle speed at the moment the ECM detects a malfunction.

Data which are stored in the ECM memory, along with the 1st trip DTC, are called 1st trip freeze frame data, and the data, stored together with the DTC data, are called freeze frame data and displayed on CONSULT-II or GST. The 1st trip freeze frame data can only be displayed on the CONSULT-II screen, not on the GST. For details, refer to [EC-98, "CONSULT-II Function \(ENGINE\)"](#).

Only one set of freeze frame data (either 1st trip freeze frame data or freeze frame data) can be stored in the ECM. 1st trip freeze frame data is stored in the ECM memory along with the 1st trip DTC. There is no priority for 1st trip freeze frame data, and it is updated each time a different 1st trip DTC is detected. However, once freeze frame data (2nd trip detection/MI on) is stored in the ECM memory, 1st trip freeze frame data is no longer stored. Remember, only one set of freeze frame data can be stored in the ECM. The ECM has the following priorities to update the data.

Priority	Items
1	Freeze frame data Misfire — DTC: P0300 - P0306 Fuel Injection System Function — DTC: P0171, P0172, P0174, P0175
2	Except the above items (Includes CVT related items)
3	1st trip freeze frame data

Both 1st trip freeze frame data and freeze frame data (along with the DTC) are cleared when the ECM memory is erased.

HOW TO ERASE DTC

The diagnostic trouble code can be erased by CONSULT-II, GST or ECM DIAGNOSTIC TEST MODE as described following.

- **If the battery cable is disconnected, the diagnostic trouble code will be lost within 24 hours.**
- **When you erase the DTC, using CONSULT-II or GST is easier and quicker than switching the mode selector on the ECM.**

The following emission-related diagnostic information is cleared from the ECM memory when erasing DTC related to OBD-II. For details, refer to [EC-36, "Emission-related Diagnostic Information"](#).

- **Diagnostic trouble codes (DTC)**
- **1st trip diagnostic trouble codes (1st trip DTC)**
- **Freeze frame data**

ON BOARD DIAGNOSTIC (OBD) SYSTEM

- 1st trip freeze frame data
- System readiness test (SRT) codes
- Test values

HOW TO ERASE DTC (WITH CONSULT-II)

- If a DTC is displayed for both ECM and TCM, it is necessary to be erased for both ECM and TCM.
1. If the ignition switch stays ON after repair work, be sure to turn ignition switch OFF once. Wait at least 10 seconds and then turn it ON (engine stopped) again.
 2. Turn CONSULT-II ON and touch "TRANSMISSION".
 3. Touch "SELF-DIAG RESULTS".
 4. Touch "ERASE". (The DTC in the TCM will be erased.) Then touch "BACK" twice.
 5. Touch "ENGINE".
 6. Touch "SELF-DIAG RESULTS".
 7. Touch "ERASE". (The DTC in the ECM will be erased.)

How to erase DTC (With CONSULT-II)

1. If the ignition switch stays "ON" after repair work, be sure to turn ignition switch "OFF" once. Wait at least 10 seconds and then turn it "ON" (engine stopped) again.

SELECT SYSTEM
IPDM E/R
BCM
AUTO DRIVE POS
AIR PRESSURE MONITOR
TRANSMISSION
METER A/C AMP

2. Turn CONSULT -II "ON", and touch "TRANSMISSION".

SELECT DIAG MODE
WORK SUPPORT
SELF-DIAG RESULTS
DATA MONITOR
CAN DIAG SUPPORT MNTR
CALIB DATA
FUNCTION TEST

3. Touch "SELF-DIAG RESULTS".

SELF-DIAG RESULTS	
DTC RESULTS	TIME
TCC SOLENOID/CIRC [P0740]	PAST

4. Touch "ERASE". (The DTC in the TCM will be erased.)

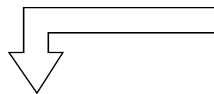

Touch "BACK".

Touch "BACK".

SELECT SYSTEM
ENGINE
ABS
AIR BAG
ALL MODE AWD/4WD
IPDM E/R
BCM

5. Touch "ENGINE".

SELECT DIAG MODE
WORK SUPPORT
SELF-DIAG RESULTS
DATA MONITOR
DATA MONITOR (SPEC)
CAN DIAG SUPPORT MNTR
ACTIVE TEST

6. Touch "SELF-DIAG RESULTS".

SELF-DIAG RESULTS	
DTC RESULTS	TIME
TCC SOLENOID/CIRC [P0740]	0

7. Touch "ERASE". (The DTC in the ECM will be erased.)

SCIA6465E

HOW TO ERASE DTC (WITH GST)

1. If the ignition switch stays ON after repair work, be sure to turn ignition switch OFF once. Wait at least 10 seconds and then turn it ON (engine stopped) again.
2. Select Mode 4 with Generic Scan Tool (GST). For details, refer to [EC-109. "Generic Scan Tool \(GST\) Function"](#).

ON BOARD DIAGNOSTIC (OBD) SYSTEM

Malfunction Indicator (MI)

EC500F5Y

DESCRIPTION

The MI is located on the instrument panel.

1. The MI will light up when the ignition switch is turned ON without the engine running. This is a bulb check.
 - If the MI does not light up, refer to [DI-37, "WARNING LAMPS"](#), or see [EC-682, "MI & DATA LINK CONNECTORS"](#).
2. When the engine is started, the MI should go off. If the MI remains on, the on board diagnostic system has detected an engine system malfunction.

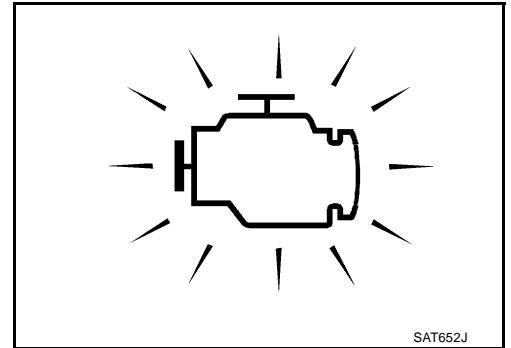

TROUBLE DIAGNOSIS

TROUBLE DIAGNOSIS

PFP:00004

DTC Inspection Priority Chart

ECS00F5Z

If some DTCs are displayed at the same time, perform inspections one by one based on the following priority chart.

NOTE:

If DTC “U1000 CAN COMM CIRCUIT” is displayed with other DTCs, first perform the trouble diagnosis for “DTC U1000 CAN COMMUNICATION LINE”. Refer to [CVT-65](#).

Priority	Detected items (DTC)
1	U1000 CAN communication line
2	Except above

Fail-safe

ECS00F60

The TCM has an electrical fail-safe mode. This mode makes it possible to operate even if there is an error in a main electronic control input/output signal circuit.

FAIL-SAFE FUNCTION

If any malfunction occurs in a sensor or solenoid, this function controls the CVT to make driving possible.

Output Speed Sensor (Secondary Speed Sensor)

- The shift pattern is changed in accordance with throttle position when an unexpected signal is sent from the output speed sensor (secondary speed sensor) to the TCM. The manual mode position and second position is inhibited, and the transaxle is put in “D”.

Input Speed Sensor (Primary Speed Sensor)

- The shift pattern is changed in accordance with throttle position and secondary speed (vehicle speed) when an unexpected signal is sent from the input speed sensor (primary speed sensor) to the TCM. The manual mode position and second position is inhibited, and the transaxle is put in “D”.

PNP Switch

- If an unexpected signal is sent from the PNP switch to the TCM, the transaxle is put in “D”.

Manual Mode Switch

- If an unexpected signal is sent from the manual mode switch to the TCM, the transaxle is put in “D”.

CVT Fluid Temperature Sensor

- If an unexpected signal is sent from the CVT fluid temperature sensor to the TCM, the gear ratio in use before receiving the unexpected signal is maintained or the gear ratio is controlled to keep engine speed under 5,000 rpm.

Transmission Fluid Pressure Sensor A (Secondary Pressure Sensor)

- If an unexpected signal is sent from the transmission fluid pressure sensor A (secondary pressure sensor) to the TCM, the secondary pressure feedback control is stopped and the offset value obtained before the non-standard condition occurs is used to control line pressure.
- If transmission fluid pressure sensor A (secondary pressure sensor) error signal is input to TCM, secondary pressure feedback control stops, but line pressure is controlled normally.

Pressure Control Solenoid A (Line Pressure Solenoid)

- If an unexpected signal is sent from the solenoid to the TCM, the pressure control solenoid A (line pressure solenoid) is turned OFF to achieve the maximum fluid pressure.

Pressure Control Solenoid B (Secondary Pressure Solenoid)

- If an unexpected signal is sent from the solenoid to the TCM, the pressure control solenoid B (secondary pressure solenoid) is turned OFF to achieve the maximum fluid pressure.

Torque Converter Clutch Solenoid

- If an unexpected signal is sent from the solenoid to the TCM, the torque converter clutch solenoid is turned OFF to cancel the lock-up.

TROUBLE DIAGNOSIS

Step Motor

- If an unexpected signal is sent from the step motor to the TCM, the step motor coil phases “A” through “D” are all turned OFF to hold the gear ratio used right before the non-standard condition occurred.

CVT Lock-up Select Solenoid

- If an unexpected signal is sent from the solenoid to the TCM, the CVT lock-up select solenoid is turned OFF to cancel the lock-up.

TCM Power Supply (Memory Back-up)

- Transaxle assembly is protected by limiting the engine torque when the memory back-up power supply (for controlling) from the battery is not supplied to TCM. Normal status is restored when turning the ignition switch OFF to ON after the normal power supply.

How to Perform Trouble Diagnosis for Quick and Accurate Repair

ECS00F61

INTRODUCTION

The TCM receives a signal from the vehicle speed sensor, PNP switch and provides shift control or lock-up control via CVT solenoid valves.

The TCM also communicates with the ECM by means of a signal sent from sensing elements used with the OBD-related parts of the CVT system for malfunction-diagnostic purposes. The TCM is capable of diagnosing malfunctioning parts while the ECM can store malfunctions in its memory.

Input and output signals must always be correct and stable in the operation of the CVT system. The CVT system must be in good operating condition and be free of valve seizure, solenoid valve malfunction, etc.

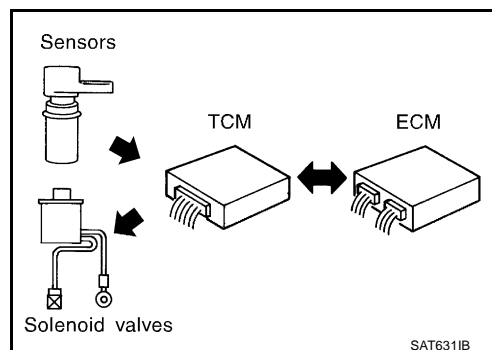

It is much more difficult to diagnose an error that occurs intermittently rather than continuously. Most intermittent errors are caused by poor electric connections or improper wiring. In this case, careful checking of suspected circuits may help prevent the replacement of good parts.

A visual check only may not find the cause of the errors. A road test with CONSULT-II (or GST) or a circuit tester connected should be performed. Follow the [CVT-31, "WORK FLOW"](#) .

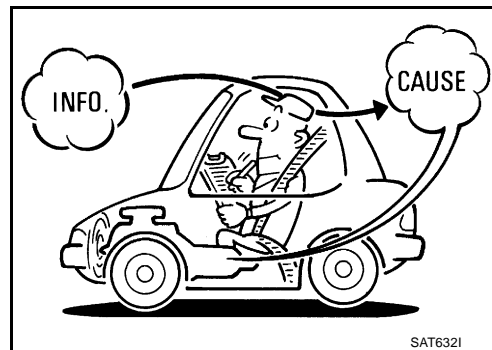

Before undertaking actual checks, take a few minutes to talk with a customer who approaches with a driveability complaint. The customer can supply good information about such errors, especially intermittent ones. Find out what symptoms are present and under what conditions they occur. A “DIAGNOSTIC WORKSHEET” as shown on the example (Refer to [CVT-32](#)) should be used.

Start your diagnosis by looking for “conventional” errors first. This will help troubleshoot driveability errors on an electronically controlled engine vehicle.

Also check related Service bulletins.

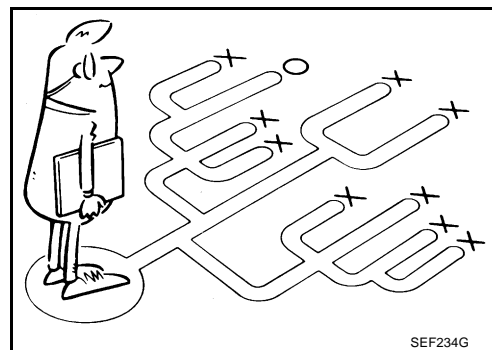

TROUBLE DIAGNOSIS

WORK FLOW

A good understanding of the malfunction conditions can make troubleshooting faster and more accurate. In general, each customer feels differently about a malfunction. It is important to fully understand the symptoms or conditions for a customer complaint.

Make good use of the two sheets provided, [CVT-32, "Information from Customer"](#) and [CVT-32, "Diagnostic Worksheet Chart"](#), to perform the best troubleshooting possible.

Work Flow Chart

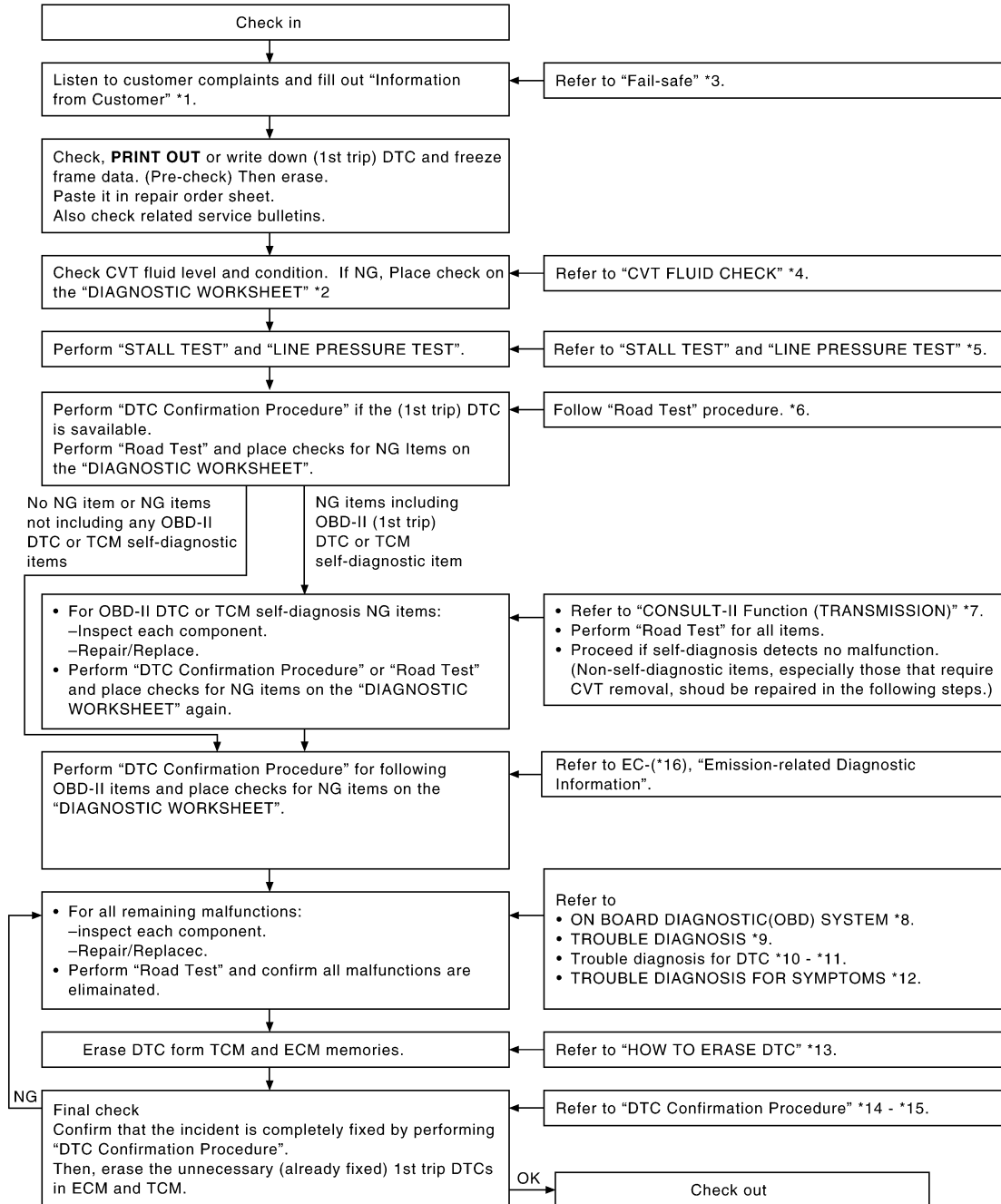

*1. [CVT-32](#)

*4. [CVT-37](#)

*7. [CVT-53](#)

*10. [CVT-65](#)

*13. [CVT-26](#)

*16. [EC-36](#)

*2. [CVT-32](#)

*5. [CVT-37](#), [CVT-39](#)

*8. [CVT-25](#)

*11. [CVT-173](#)

*14. [CVT-65](#)

*3. [CVT-29](#)

*6. [CVT-41](#)

*9. [CVT-29](#)

*12. [CVT-176](#)

*15. [CVT-173](#)

SCIA6877E

TROUBLE DIAGNOSIS

DIAGNOSTIC WORKSHEET

Information from Customer

KEY POINTS

- **WHAT.....** Vehicle & CVT model
- **WHEN.....** Date, Frequencies
- **WHERE.....** Road conditions
- **HOW.....** Operating conditions, Symptoms

Customer name	MR/MS	Model & Year	VIN
Trans. Model	Engine	Mileage	
Malfunction Date	Manuf. Date	In Service Date	
Frequency	<input type="checkbox"/> Continuous <input type="checkbox"/> Intermittent (times a day)		
Symptoms	<input type="checkbox"/> Vehicle does not move. (<input type="checkbox"/> Any position <input type="checkbox"/> Particular position)		
	<input type="checkbox"/> No shift		
	<input type="checkbox"/> Lock-up malfunction		
	<input type="checkbox"/> Shift shock or slip (<input type="checkbox"/> N → D <input type="checkbox"/> N → R <input type="checkbox"/> Lock-up <input type="checkbox"/> Any drive position)		
	<input type="checkbox"/> Noise or vibration		
	<input type="checkbox"/> No pattern select		
Malfunction indicator (MI)	<input type="checkbox"/> Continuously lit		<input type="checkbox"/> Not lit

Diagnostic Worksheet Chart

1	<input type="checkbox"/> Read the item on cautions concerning fail-safe and understand the customer's complaint.	CVT-29
2	<input type="checkbox"/> CVT fluid inspection	CVT-37
	<input type="checkbox"/> Leak (Repair leak location.) <input type="checkbox"/> State <input type="checkbox"/> Amount	
3	<input type="checkbox"/> Stall test and line pressure test	
	<input type="checkbox"/> Stall test	
	<input type="checkbox"/> Torque converter one-way clutch <input type="checkbox"/> Reverse brake <input type="checkbox"/> Forward clutch <input type="checkbox"/> Steel belt	<input type="checkbox"/> Engine <input type="checkbox"/> Line pressure low <input type="checkbox"/> Primary pulley <input type="checkbox"/> Secondary pulley
<input type="checkbox"/> Line pressure inspection - Suspected part:		

TROUBLE DIAGNOSIS

	<input type="checkbox"/> Perform road test.		CVT-41	A
4	4-1.	Check before engine is started	CVT-44	B
		<input type="checkbox"/> CVT-184, "CVT Indicator Lamp Does Not Come On" <input type="checkbox"/> Perform self-diagnosis. Enter checks for detected items. CVT-58		C
		<input type="checkbox"/> CVT-65, "DTC U1000 CAN COMMUNICATION LINE" . <input type="checkbox"/> CVT-68, "DTC P0615 START SIGNAL CIRCUIT" . <input type="checkbox"/> CVT-72, "DTC P0703 STOP LAMP SWITCH CIRCUIT" . <input type="checkbox"/> CVT-74, "DTC P0705 PARK/NEUTRAL POSITION SWITCH" . <input type="checkbox"/> CVT-81, "DTC P0710 CVT FLUID TEMPERATURE SENSOR CIRCUIT" . <input type="checkbox"/> CVT-86, "DTC P0715 INPUT SPEED SENSOR CIRCUIT (PRI SPEED SENSOR)" . <input type="checkbox"/> CVT-91, "DTC P0720 VEHICLE SPEED SENSOR CVT (SECONDARY SPEED SENSOR)" . <input type="checkbox"/> CVT-97, "DTC P0725 ENGINE SPEED SIGNAL" . <input type="checkbox"/> CVT-99, "DTC P0730 BELT DAMAGE" . <input type="checkbox"/> CVT-101, "DTC P0740 TORQUE CONVERTER CLUTCH SOLENOID VALVE" . <input type="checkbox"/> CVT-106, "DTC P0744 A/T TCC S/V FUNCTION (LOCK-UP)" . <input type="checkbox"/> CVT-109, "DTC P0745 LINE PRESSURE SOLENOID VALVE" . <input type="checkbox"/> CVT-114, "DTC P0746 PRESSURE CONTROL SOLENOID A PERFORMANCE (LINE PRESSURE SOLENOID VALVE)" . <input type="checkbox"/> CVT-117, "DTC P0776 PRESSURE CONTROL SOLENOID B PERFORMANCE (SEC PRESSURE SOLENOID VALVE)" . <input type="checkbox"/> CVT-120, "DTC P0778 PRESSURE CONTROL SOLENOID B ELECTRICAL (SEC PRESSURE SOLENOID VALVE)" . <input type="checkbox"/> CVT-125, "DTC P0826 MANUAL MODE SWITCH CIRCUIT" . <input type="checkbox"/> CVT-132, "DTC P0840 TRANSMISSION FLUID PRESSURE SENSOR A CIRCUIT (SEC PRESSURE SENSOR)" . <input type="checkbox"/> CVT-137, "DTC P0841 PRESSURE SENSOR FUNCTION" . <input type="checkbox"/> CVT-140, "DTC P0845 TRANSMISSION FLUID PRESSURE SENSOR B CIRCUIT (PRI PRESSURE SENSOR)" . <input type="checkbox"/> CVT-145, "DTC P0868 SECONDARY PRESSURE DOWN" . <input type="checkbox"/> CVT-148, "DTC P1701 TRANSMISSION CONTROL MODULE (POWER SUPPLY)" . <input type="checkbox"/> CVT-155, "DTC P1705 THROTTLE POSITION SENSOR" . <input type="checkbox"/> CVT-157, "DTC P1722 ESTM VEHICLE SPEED SIGNAL" . <input type="checkbox"/> CVT-159, "DTC P1723 CVT SPEED SENSOR FUNCTION" . <input type="checkbox"/> CVT-161, "DTC P1726 ELECTRIC THROTTLE CONTROL SYSTEM" . <input type="checkbox"/> CVT-163, "DTC P1740 LOCK-UP SELECT SOLENOID VALVE CIRCUIT" . <input type="checkbox"/> CVT-169, "DTC P1777 STEP MOTOR - CIRCUIT" . <input type="checkbox"/> CVT-173, "DTC P1778 STEP MOTOR - FUNCTION" .		D E F G H I J K
4-2.	Check at idle	CVT-44	L	
	<input type="checkbox"/> CVT-186, "Engine Cannot Be Started in "P" or "N" Position" . <input type="checkbox"/> CVT-187, "In "P" Position, Vehicle Moves Forward or Backward When Pushed" . <input type="checkbox"/> CVT-188, "In "N" Position, Vehicle Moves" . <input type="checkbox"/> CVT-189, "Large Shock "N" → "R" Position" . <input type="checkbox"/> CVT-191, "Vehicle Does Not Creep Backward in "R" Position" . <input type="checkbox"/> CVT-193, "Vehicle Does Not Creep Forward in "D" Position" .		M	

CVT

TROUBLE DIAGNOSIS

4	4-3.	<p>Cruise test</p> <p><input type="checkbox"/> CVT-195, "CVT Does Not Shift" .</p> <p><input type="checkbox"/> CVT-197, "Cannot Be Changed to Manual Mode" .</p> <p><input type="checkbox"/> CVT-198, "CVT Does Not Shift in Manual Mode" .</p> <p><input type="checkbox"/> CVT-200, "Vehicle Does Not Decelerate by Engine Brake" .</p> <p><input type="checkbox"/> Perform self-diagnosis. Enter checks for detected items. CVT-58</p> <hr/> <p><input type="checkbox"/> CVT-65, "DTC U1000 CAN COMMUNICATION LINE" .</p> <p><input type="checkbox"/> CVT-68, "DTC P0615 START SIGNAL CIRCUIT" .</p> <p><input type="checkbox"/> CVT-72, "DTC P0703 STOP LAMP SWITCH CIRCUIT" .</p> <p><input type="checkbox"/> CVT-74, "DTC P0705 PARK/NEUTRAL POSITION SWITCH" .</p> <p><input type="checkbox"/> CVT-81, "DTC P0710 CVT FLUID TEMPERATURE SENSOR CIRCUIT" .</p> <p><input type="checkbox"/> CVT-86, "DTC P0715 INPUT SPEED SENSOR CIRCUIT (PRI SPEED SENSOR)" .</p> <p><input type="checkbox"/> CVT-91, "DTC P0720 VEHICLE SPEED SENSOR CVT (SECONDARY SPEED SENSOR)" .</p> <p><input type="checkbox"/> CVT-97, "DTC P0725 ENGINE SPEED SIGNAL" .</p> <p><input type="checkbox"/> CVT-99, "DTC P0730 BELT DAMAGE" .</p> <p><input type="checkbox"/> CVT-101, "DTC P0740 TORQUE CONVERTER CLUTCH SOLENOID VALVE" .</p> <p><input type="checkbox"/> CVT-106, "DTC P0744 A/T TCC S/V FUNCTION (LOCK-UP)" .</p> <p><input type="checkbox"/> CVT-109, "DTC P0745 LINE PRESSURE SOLENOID VALVE" .</p> <p><input type="checkbox"/> CVT-114, "DTC P0746 PRESSURE CONTROL SOLENOID A PERFORMANCE (LINE PRESSURE SOLENOID VALVE)" .</p> <p><input type="checkbox"/> CVT-117, "DTC P0776 PRESSURE CONTROL SOLENOID B PERFORMANCE (SEC PRESSURE SOLENOID VALVE)" .</p> <p><input type="checkbox"/> CVT-120, "DTC P0778 PRESSURE CONTROL SOLENOID B ELECTRICAL (SEC PRESSURE SOLENOID VALVE)" .</p> <p><input type="checkbox"/> CVT-125, "DTC P0826 MANUAL MODE SWITCH CIRCUIT" .</p> <p><input type="checkbox"/> CVT-132, "DTC P0840 TRANSMISSION FLUID PRESSURE SENSOR A CIRCUIT (SEC PRESSURE SENSOR)" .</p> <p><input type="checkbox"/> CVT-137, "DTC P0841 PRESSURE SENSOR FUNCTION" .</p> <p><input type="checkbox"/> CVT-140, "DTC P0845 TRANSMISSION FLUID PRESSURE SENSOR B CIRCUIT (PRI PRESSURE SENSOR)" .</p> <p><input type="checkbox"/> CVT-145, "DTC P0868 SECONDARY PRESSURE DOWN" .</p> <p><input type="checkbox"/> CVT-148, "DTC P1701 TRANSMISSION CONTROL MODULE (POWER SUPPLY)" .</p> <p><input type="checkbox"/> CVT-155, "DTC P1705 THROTTLE POSITION SENSOR" .</p> <p><input type="checkbox"/> CVT-157, "DTC P1722 ESTM VEHICLE SPEED SIGNAL" .</p> <p><input type="checkbox"/> CVT-159, "DTC P1723 CVT SPEED SENSOR FUNCTION" .</p> <p><input type="checkbox"/> CVT-161, "DTC P1726 ELECTRIC THROTTLE CONTROL SYSTEM" .</p> <p><input type="checkbox"/> CVT-163, "DTC P1740 LOCK-UP SELECT SOLENOID VALVE CIRCUIT" .</p> <p><input type="checkbox"/> CVT-169, "DTC P1777 STEP MOTOR - CIRCUIT" .</p> <p><input type="checkbox"/> CVT-173, "DTC P1778 STEP MOTOR - FUNCTION" .</p>	CVT-47
5	<input type="checkbox"/> Inspect each system for items found to be NG in the self-diagnosis and repair or replace the malfunctioning parts.		
6	<input type="checkbox"/> Perform all road tests and enter the checks again for the required items.		CVT-41
7	<input type="checkbox"/> For any remaining NG items, perform the "diagnosis procedure" and repair or replace the malfunctioning parts.		
8	<input type="checkbox"/> Erase the results of the self-diagnosis from the TCM.		CVT-27, CVT-27

TROUBLE DIAGNOSIS

CVT Electrical Parts Location

ECS00F62

A
B
CVT
D
E
F
G
H
I
J
K
L
M

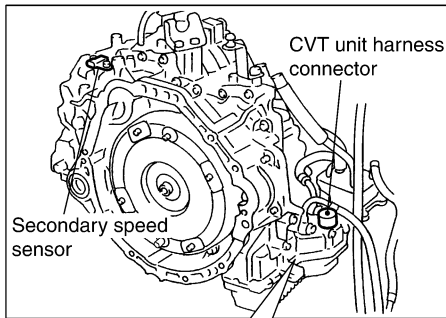
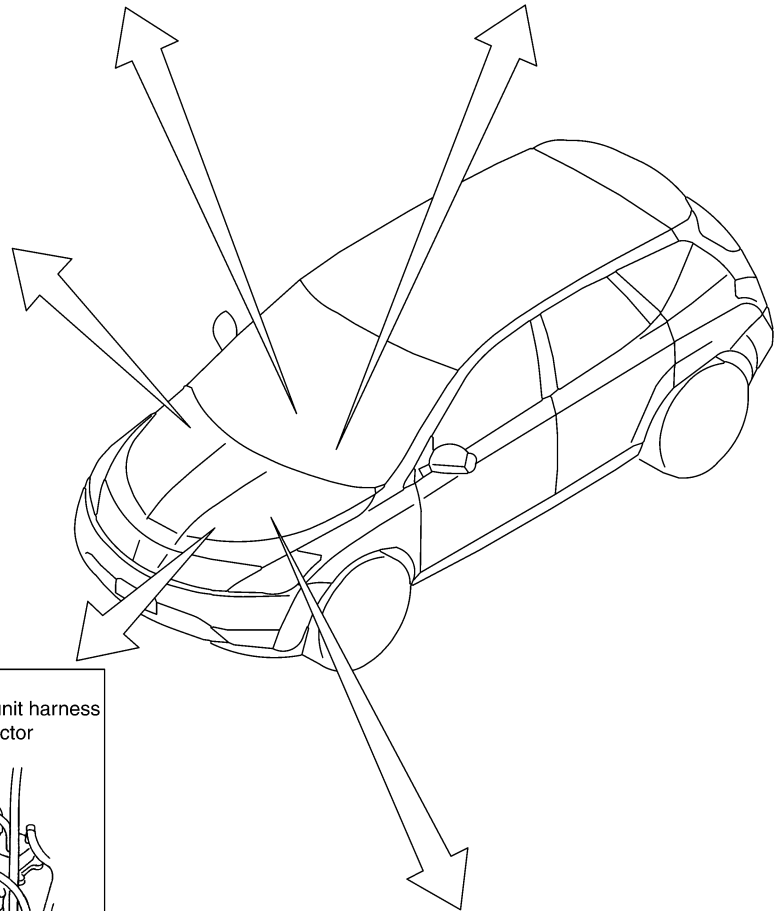
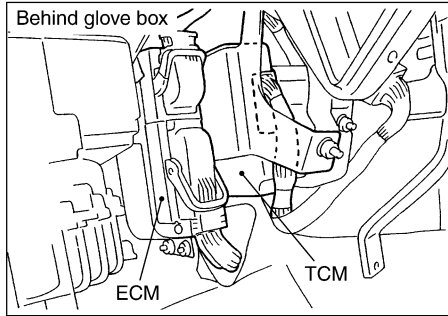
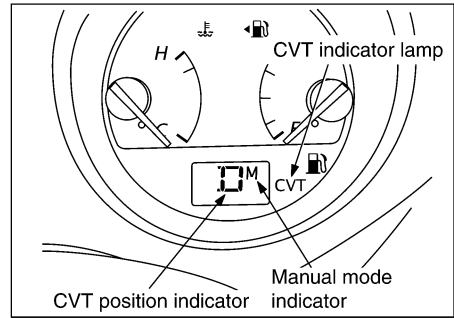
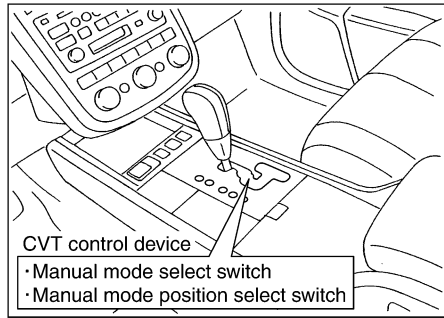

Control valve assembly

- PNP switch
- Primary speed sensor
- Step motor
- Secondary pressure solenoid valve
- Line pressure solenoid valve
- Torque converter clutch solenoid valve
- Shift control valve
- Secondary valve
- Manual valve
- Torque converter clutch control valve
- Lock-up select solenoid valve
- CVT fluid temperature sensor
- Secondary pressure sensor
- Primary pressure sensor

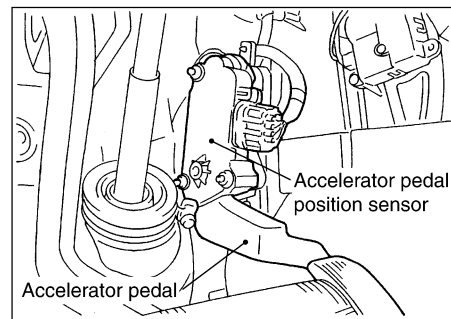

SCIA6472E

TROUBLE DIAGNOSIS

Circuit Diagram

ECS00F64

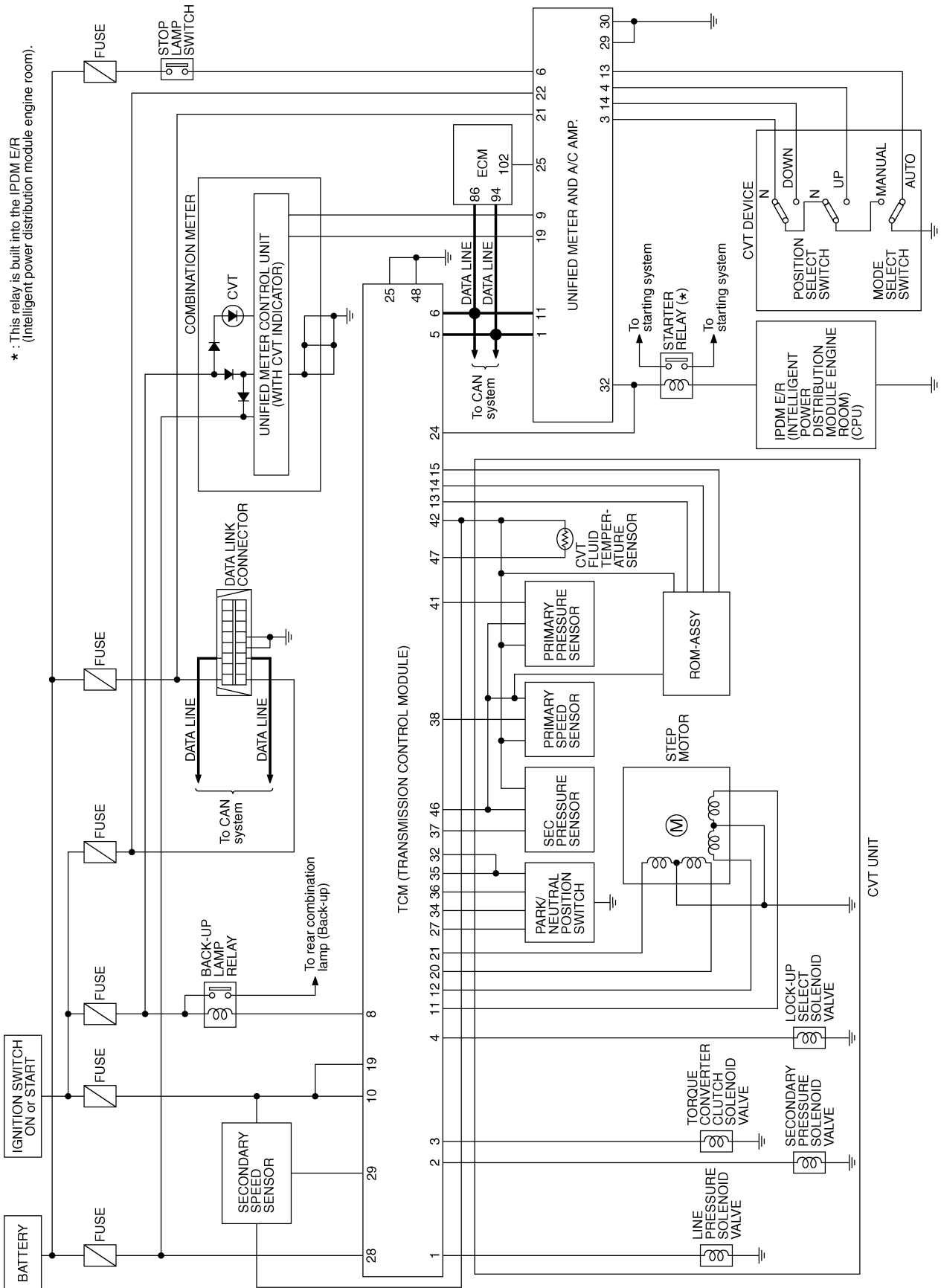

TCWB0135E

TROUBLE DIAGNOSIS

ECS00F65

Inspections Before Trouble Diagnosis

CVT FLUID CHECK

Fluid Leakage and Fluid Level Check

- Inspect for fluid leakage and check the fluid level. Refer to [CVT-14, "Checking CVT Fluid"](#).

Fluid Condition Check

Inspect the fluid condition.

Fluid status	Conceivable cause	Required operation
Varnished (viscous varnish state)	Clutch, brake scorched	Replace the CVT fluid and check the CVT main unit and the vehicle for malfunctions (wire harnesses, cooler pipes, etc.)
Milky white or cloudy	Water in the fluid	Replace the CVT fluid and check for places where water is getting in.
Large amount of metal powder mixed in	Unusual wear of sliding parts within CVT	Replace the CVT fluid and check for improper operation of the CVT.

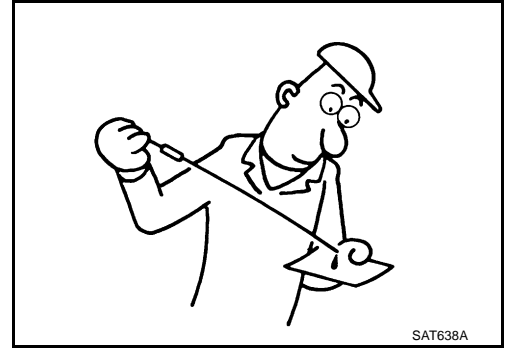

STALL TEST

Stall Test Procedure

- Inspect the amount of engine oil. Replenish the engine oil if necessary.
- Drive for about 10 minutes to warm up the vehicle so that the CVT fluid temperature is 50 to 80°C (122 to 176°F). Inspect the amount of CVT fluid. Replenish if necessary.

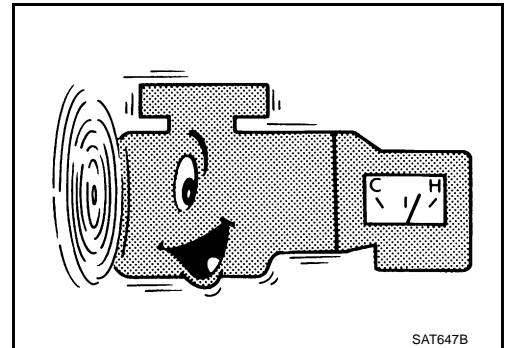

- Securely engage the parking brake so that the tires do not turn.
- Install a tachometer where it can be seen by driver during test.
 - It is good practice to mark the point of specified engine rpm on indicator.

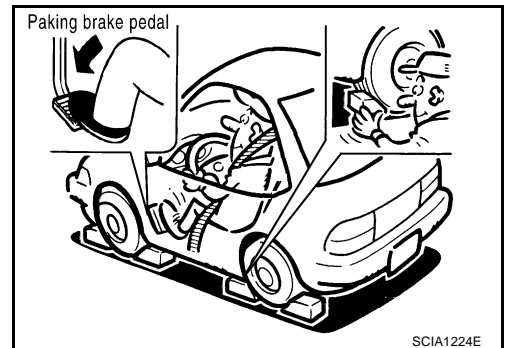

- Start engine, apply foot brake, and place selector lever in "D" position.

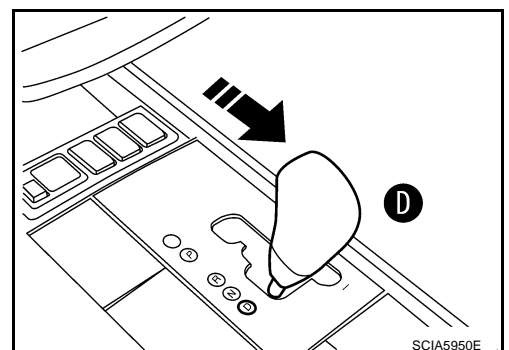

A
B
CVT
D
E
F
G
H
I
J
K
L
M

TROUBLE DIAGNOSIS

6. While holding down the foot brake, gradually press down the accelerator pedal.
7. Quickly read off the stall speed, and then quickly remove your foot from the accelerator pedal.

CAUTION:

Do not hold down the accelerator pedal for more than 5 seconds during this test.

Stall speed: 2,700 - 3,250 rpm

8. Move the selector lever to the “N” position.
9. Cool down the CVT fluid.

CAUTION:

Run the engine at idle for at least one minute.

10. Repeat steps 6 through 9 with selector lever in “R” position.

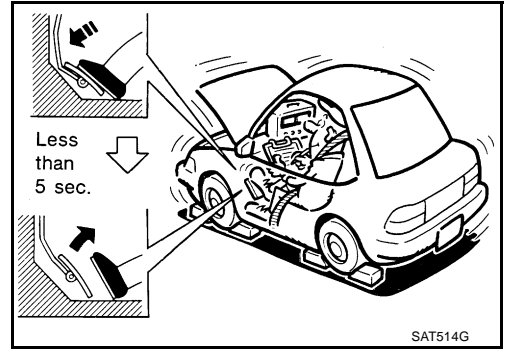

Judgement Stall Test

	Selector lever position		Expected problem location
	“D”	“R”	
Stall rotation	H	O	● Forward clutch
	O	H	● Reverse brake
	L	L	● Engine and torque converter one-way clutch
	H	H	<ul style="list-style-type: none"> ● Line pressure low ● Primary pulley ● Secondary pulley ● Steel belt

O: Stall speed within standard value position.

H: Stall speed is higher than standard value.

L: Stall speed is lower than standard value.

TROUBLE DIAGNOSIS

LINE PRESSURE TEST

Line Pressure Test Port

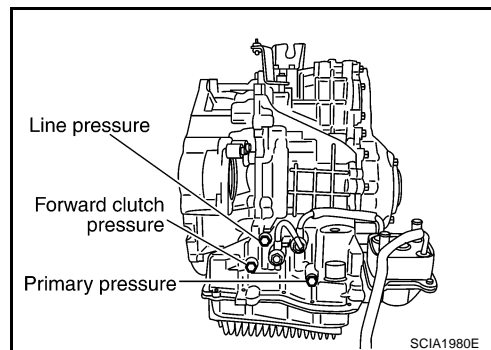

Line Pressure Test Procedure

1. Inspect the amount of engine oil and replenish if necessary.
2. Drive the car for about 10 minutes to warm it up so that the CVT fluid reaches in the range of 50 to 80°C (122 to 176°F), then inspect the amount of CVT fluid and replenish if necessary.

NOTE:

The CVT fluid temperature rises in the range of 50 to 80°C (122 to 176°F) during 10 minutes of driving.

3. After warming up CVT, remove the oil pressure detection plug and install the oil pressure gauge. (Special service tool: ST2505S001)

CAUTION:

When using the oil pressure gauge, be sure to use the O-ring attached to the oil pressure detection plug.

4. Securely engage the parking brake so that the tires do not turn.

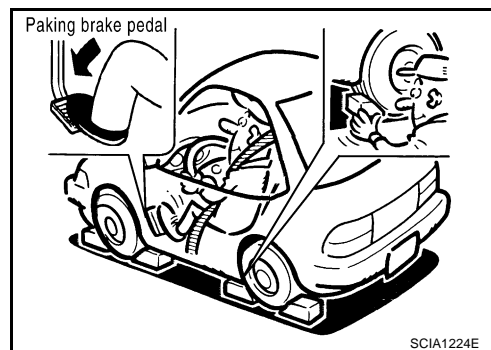

5. Start the engine, and then measure the line pressure at both idle and the stall speed.

CAUTION:

- Keep the brake pedal pressed all the way down during measurement.
- When measuring the line pressure at the stall speed, refer to [CVT-37, "STALL TEST"](#).

6. After the measurements are complete, install the oil pressure detection plug and tighten to the specified torque below.

 : 7.5 N·m (0.77 kg·m, 66 in·lb)

CAUTION:

- Do not reuse O-ring.
- Apply CVT fluid to O-ring.

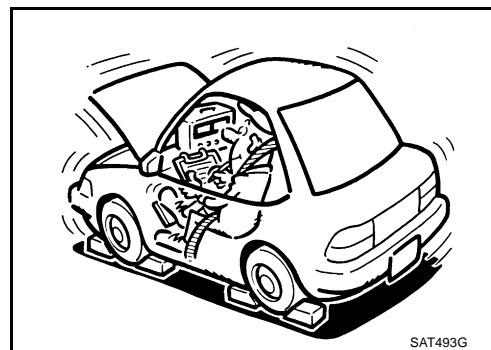

TROUBLE DIAGNOSIS

Line Pressure

Engine	Engine speed	Line pressure kPa (kg/cm ² , psi)
		"R", "D" positions
VQ35DE	At idle speed	750 (7.65, 108.8)
	At stall speed	5,700 (58.14, 826.5)* ¹

*¹ : Reference values

Judgement of Line Pressure Test

Judgement		Possible cause
Idle speed	Low for all positions ("P", "R", "N", "D")	<p>Possible causes include malfunctions in the pressure supply system and low oil pump output. For example</p> <ul style="list-style-type: none"> ● Oil pump wear ● Pressure regulator valve or plug sticking or spring fatigue ● Oil strainer ⇒ oil pump ⇒ pressure regulator valve passage oil leak ● Engine idle speed too low
	Only low for a specific position	<p>Possible causes include an oil pressure leak in a passage or device related to the position after the pressure is distributed by the manual valve.</p>
	High	<p>Possible causes include a sensor malfunction or malfunction in the line pressure adjustment function. For example</p> <ul style="list-style-type: none"> ● Accelerator pedal position signal malfunction ● CVT fluid temperature sensor malfunction ● Pressure control solenoid A (line pressure solenoid) malfunction (sticking in "OFF" state, filter clog, cut line) ● Pressure regulator valve or plug sticking
Stall speed	Oil pressure does not rise higher than the oil pressure for idle.	<p>Possible causes include a sensor malfunction or malfunction in the pressure adjustment function. For example</p> <ul style="list-style-type: none"> ● Accelerator pedal position signal malfunction ● TCM malfunction ● Pressure control solenoid A (line pressure solenoid) malfunction (shorting, sticking in "ON" state) ● Pressure regulator valve or plug sticking
	The pressure rises, but does not enter the standard position.	<p>Possible causes include malfunctions in the pressure supply system and malfunction in the pressure adjustment function. For example</p> <ul style="list-style-type: none"> ● Accelerator pedal position signal malfunction ● Pressure control solenoid A (line pressure solenoid) malfunction (sticking, filter clog) ● Pressure regulator valve or plug sticking
	Only low for a specific position	<p>Possible causes include an oil pressure leak in a passage or device related to the position after the pressure is distributed by the manual valve.</p>

TROUBLE DIAGNOSIS

ECS00F66

Road Test DESCRIPTION

- The purpose of the test is to determine overall performance of CVT and analyze causes of problems.
- The road test consists of the following three parts:
 1. "Check Before Engine Is Started" [CVT-44](#) .
 2. "Check at Idle" [CVT-44](#) .
 3. "Cruise Test" [CVT-47](#) .

ROAD TEST PROCEDURE

1. Check before engine is started.



2. Check at idle.



3. Cruise test.

SAT786A

- Before road test, familiarize yourself with all test procedures and items to check.
- Perform tests on all items until specified symptom is found. Troubleshoot items which check out No Good after road test. Refer to [CVT-25, "ON BOARD DIAGNOSTIC \(OBD\) SYSTEM"](#) .



SAT496G

CONSULT-II SETTING PROCEDURE

CAUTION:

If CONSULT-II is used with no connection of CONSULT-II CONVERTER, malfunctions might be detected in self-diagnosis depending on control unit which performs CAN communication.

- Using CONSULT-II, perform a cruise test and record the result.
- Print the result and ensure that shifts and lock-ups take place as per Shift Schedule.

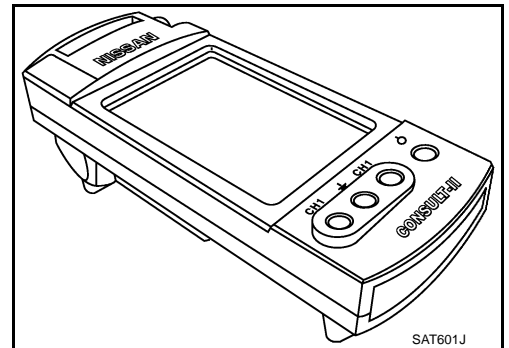

SAT601J

1. Turn ignition switch OFF.
2. Connect CONSULT-II and CONSULT-II CONVERTER to data link connector, which is located in instrument driver lower panel on driver side.

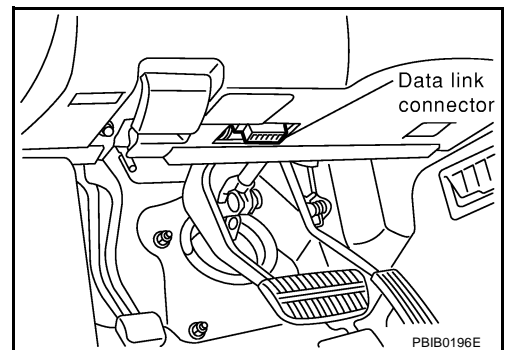

Data link connector

PBIB0196E

A
B
CVT
D
E
F
G
H
I
J
K
L
M

TROUBLE DIAGNOSIS

3. Turn ignition switch ON.
4. Touch "START (NISSAN BASED VHCL)".

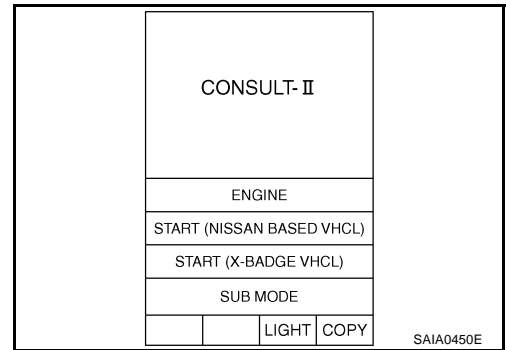

5. Touch "TRANSMISSION".
If "TRANSMISSION" is not indicated, go to [GI-35, "CONSULT-II Data Link Connector \(DLC\) Circuit"](#) .

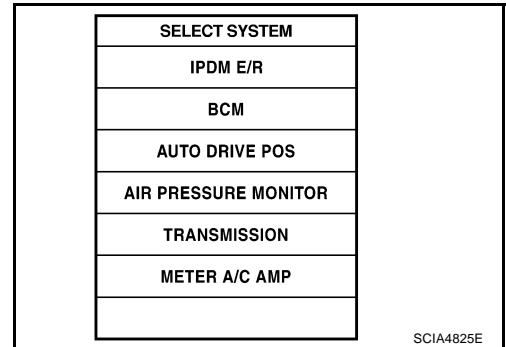

6. Touch "DATA MONITOR".

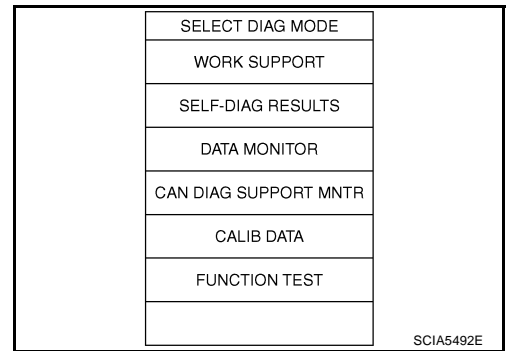

7. Touch "MAIN SIGNALS" to set recording condition.
8. See "Numerical Display", "Barchart Display" or "Line Graph Display".
9. Touch "START".

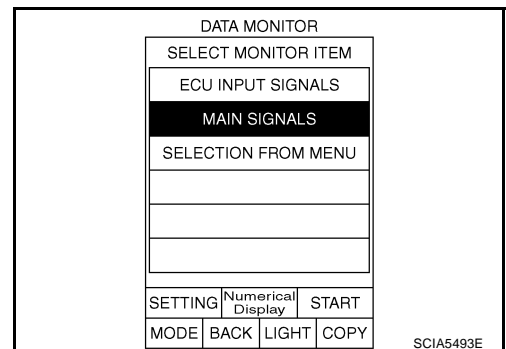

10. When performing cruise test. Refer to [CVT-47, "Cruise Test"](#) .
11. After finishing cruise test part, touch "RECORD".

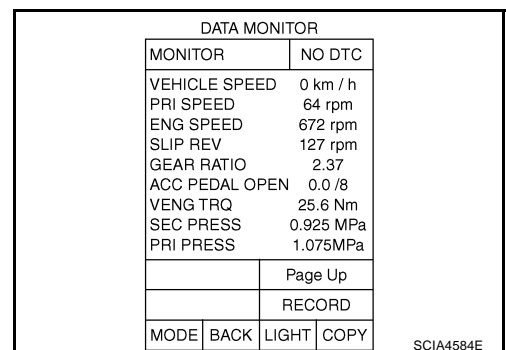

TROUBLE DIAGNOSIS

12. Touch "STORE".

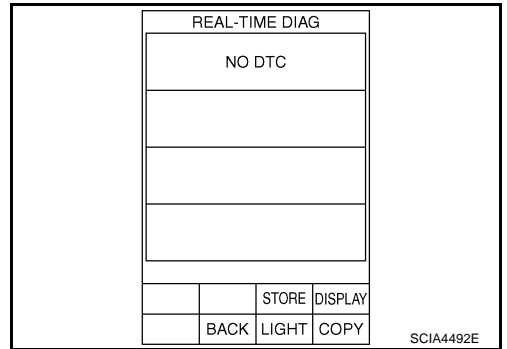

A
B
CVT

13. Touch "BACK".

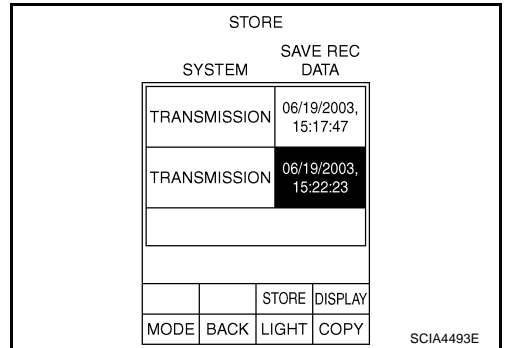

D
E
F
G

14. Touch "DISPLAY".

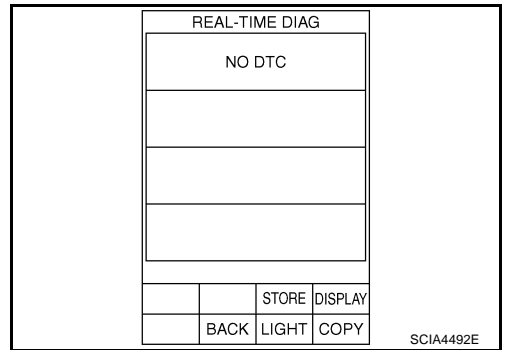

H
I
J
K

15. Touch "PRINT".

16. Check the monitor data printed out.

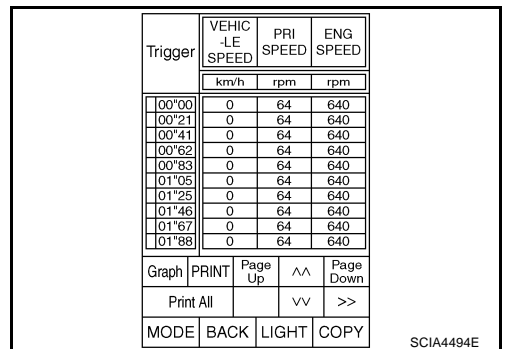

L
M

TROUBLE DIAGNOSIS

Check Before Engine Is Started

ECS00F67

1. CHECK CVT INDICATOR LAMP

1. Park vehicle on flat surface.
2. Move selector lever to "P" position.
3. Turn ignition switch OFF. Wait at least 5 seconds.
4. Turn ignition switch ON. (Do not start engine.)

Does CVT indicator lamp come on for about 2 seconds?

YES >> 1. Turn ignition switch OFF.

2. Perform self-diagnosis and note NG items.
Refer to [CVT-58, "SELF-DIAGNOSTIC RESULT MODE"](#).

3. Go to [CVT-44, "Check at Idle"](#).

NO >> Stop "Road Test". Go to [CVT-184, "CVT Indicator Lamp Does Not Come On"](#).

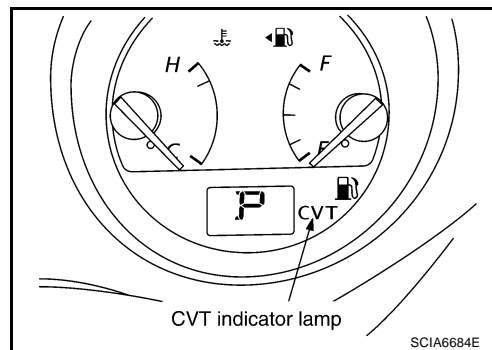

Check at Idle

ECS00F68

1. CHECK STARTING THE ENGINE

1. Park vehicle on flat surface.
2. Move selector lever to "P" or "N" position.
3. Turn ignition switch OFF.
4. Turn ignition switch to START position.

Is engine started?

YES >> GO TO 2.

NO >> Stop "Road Test". Mark the box on the [CVT-32, "DIAGNOSTIC WORKSHEET"](#). Go to [CVT-186, "Engine Cannot Be Started in "P" or "N" Position"](#).

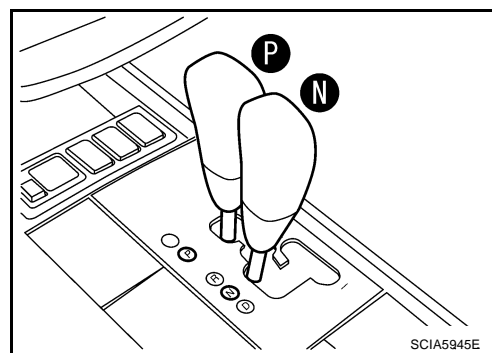

2. CHECK STARTING THE ENGINE

1. Turn ignition switch ON.
2. Move selector lever to "D", "M" or "R" position.
3. Turn ignition switch to START position.

Is engine started?

YES >> Stop "Road Test". Mark the box on the [CVT-32, "DIAGNOSTIC WORKSHEET"](#). Go to [CVT-186, "Engine Cannot Be Started in "P" or "N" Position"](#).

NO >> GO TO 3.

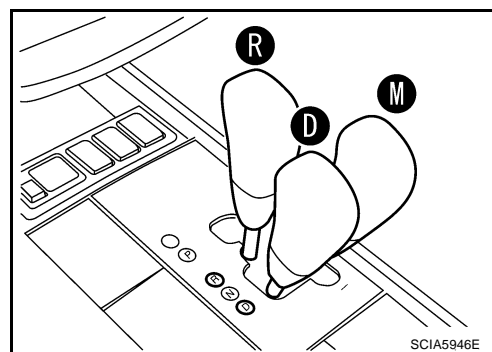

TROUBLE DIAGNOSIS

3. CHECK "P" POSITION FUNCTION

1. Move selector lever to "P" position.
2. Turn ignition switch OFF.
3. Release parking brake.

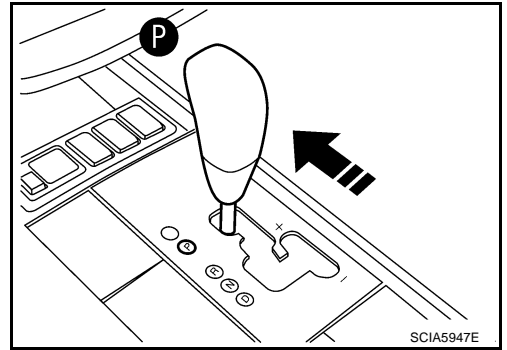

4. Push vehicle forward or backward.
5. Apply parking brake.

Does vehicle move when it is pushed forward or backward?

YES >> Mark the box "In "P" Position, Vehicle Moves Forward or Backward When Pushed" on the [CVT-32, "DIAGNOSTIC WORKSHEET"](#) . Continue "Road Test".

NO >> GO TO 4.

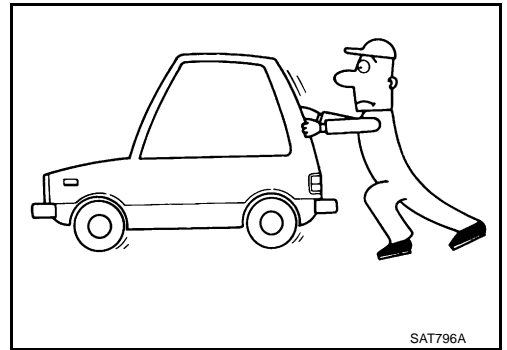

4. CHECK "N" POSITION FUNCTION

1. Start engine.
2. Move selector lever to "N" position.
3. Release parking brake.

Does vehicle move forward or backward?

YES >> Mark the box "In "N" Position, Vehicle Moves" on the [CVT-32, "DIAGNOSTIC WORKSHEET"](#) . Continue "Road Test".

NO >> GO TO 5.

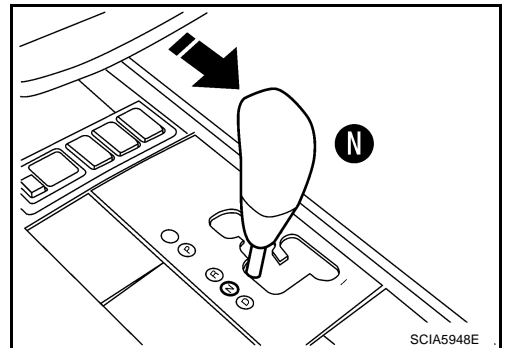

A
B
CVT
D
E
F
G
H
I
J
K
L
M

TROUBLE DIAGNOSIS

5. CHECK SHIFT SHOCK

1. Apply foot brake.

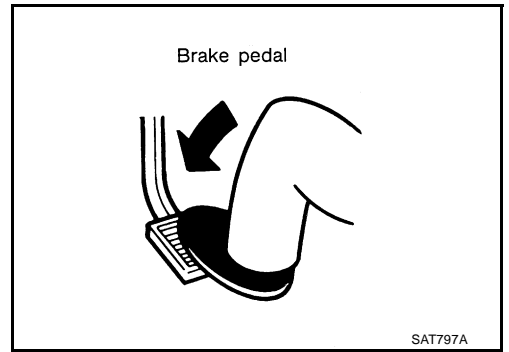

2. Move selector lever to "R" position.

Is there large shock when changing from "N" to "R" position?

- YES >> Mark the box "Large shock "N" → "R" Position" on the [CVT-32, "DIAGNOSTIC WORKSHEET"](#) . Continue "Road Test".
- NO >> GO TO 6.

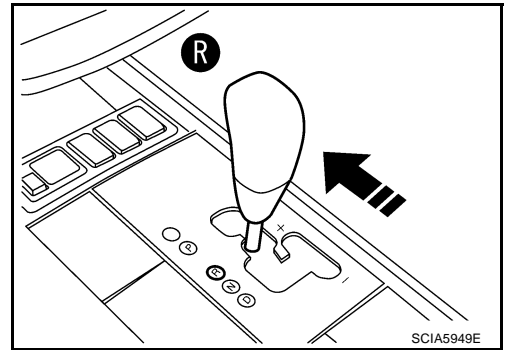

6. CHECK "R" POSITION FUNCTION

Release foot brake for several seconds.

Does vehicle creep backward when foot brake is released?

- YES >> GO TO 7.
- NO >> Mark the box "Vehicle Does Not Creep Backward in "R" Position" on the [CVT-32, "DIAGNOSTIC WORKSHEET"](#) . Continue "Road Test".

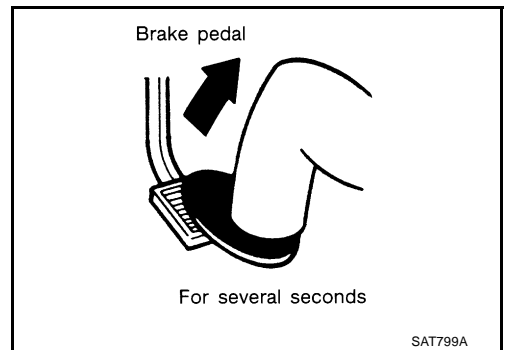

7. CHECK "D" POSITION FUNCTION

Move selector lever to "D" position and check if vehicle creeps forward.

Does vehicle creep forward in all four positions?

- YES >> Go to [CVT-47, "Cruise Test"](#) .
- NO >> Mark the box "Vehicle Does Not Creep Forward in "D" Position" on the [CVT-32, "DIAGNOSTIC WORKSHEET"](#) . Continue "Road Test".

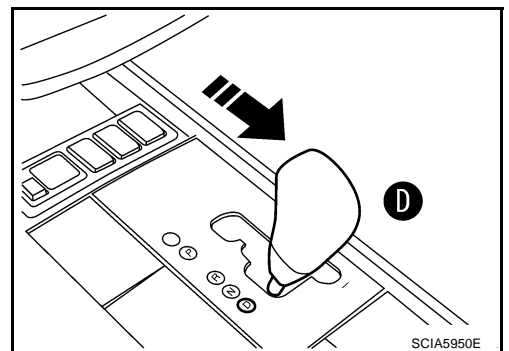

TROUBLE DIAGNOSIS

Cruise Test

ECS00F69

1. CHECK VEHICLE SPEED WHEN SHIFTING GEARS — PART 1

1. Drive vehicle for approximately 10 minutes to warm engine oil and CVT fluid up to operating temperature.

CVT fluid operating temperature: 50 - 80°C (122 - 176°F)

2. Park vehicle on flat surface.
3. Move selector lever to "P" position.
4. Start engine.

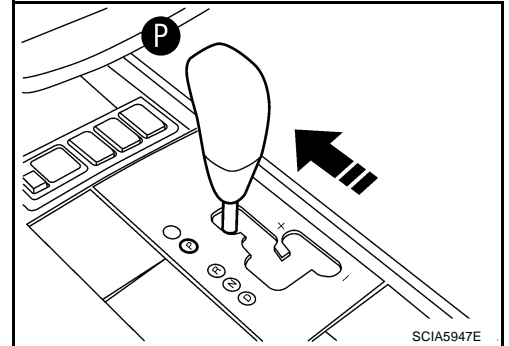

5. Move selector lever to "D" position.

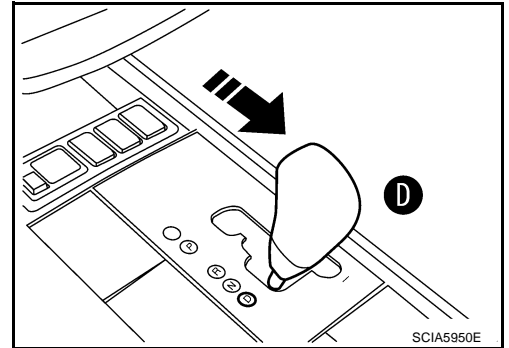

6. Accelerate vehicle to 2/8-way throttle depressing accelerator pedal constantly.

Ⓜ Read vehicle speed and engine speed. Refer to [CVT-49, "Vehicle Speed at Which Gear Shifting Occurs"](#).

OK or NG

OK >> GO TO 2.

NG >> Mark the box of "CVT Does Not Shift" on the [CVT-32, "DIAGNOSTIC WORKSHEET"](#). Continue "Road Test".

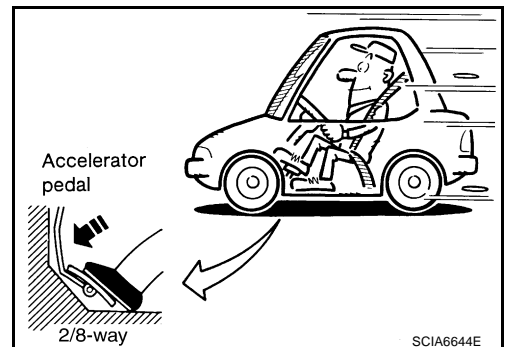

A
B
CVT
D
E
F
G
H
I
J
K
L
M

TROUBLE DIAGNOSIS

2. CHECK VEHICLE SPEED WHEN SHIFTING GEARS — PART 2

1. Park vehicle on flat surface.
2. Move selector lever to "D" position.

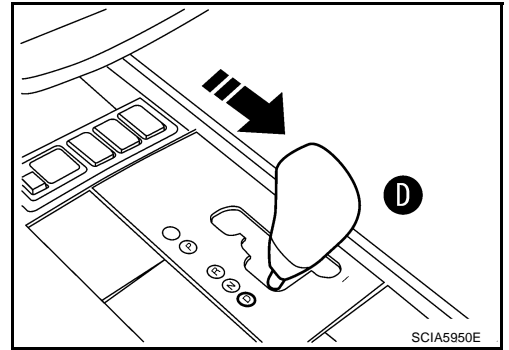

3. Accelerate vehicle to full depression depressing accelerator pedal constantly.
Ⓟ Read vehicle speed and engine speed. Refer to [CVT-49, "Vehicle Speed at Which Gear Shifting Occurs"](#).

OK or NG

OK >> GO TO 3.

NG >> Mark the box of "CVT Does Not Shift" on the [CVT-32, "DIAGNOSTIC WORKSHEET"](#). Continue "Road Test".

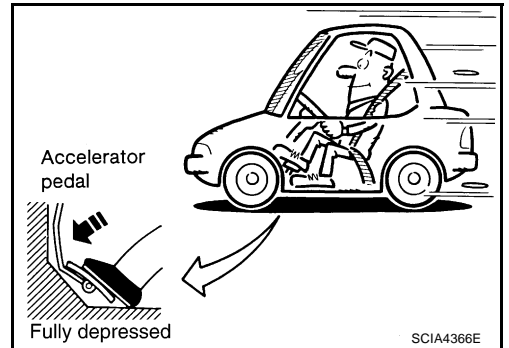

3. CHECK MANUAL MODE FUNCTION

Move to manual mode from "D" position.

Does it switch to manual mode?

YES >> GO TO 4.

NO >> Mark the box of "Cannot Be Changed to Manual Mode" on the [CVT-32, "DIAGNOSTIC WORKSHEET"](#). Continue "Road Test".

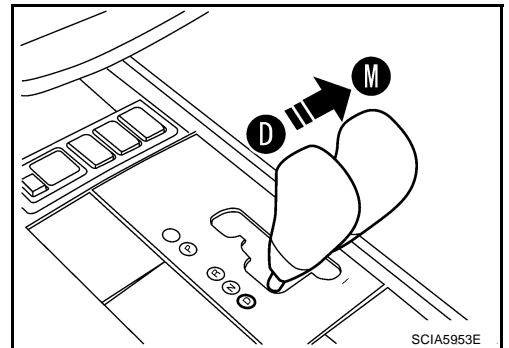

4. CHECK SHIFT-UP FUNCTION

During manual mode driving, is upshift from M1 → M2 → M3 → M4 → M5 → M6 performed?

Ⓟ Read the gear position. Refer to [CVT-61, "DATA MONITOR MODE"](#).

Is upshifting correctly performed?

YES >> GO TO 5.

NO >> Mark the box of "CVT Does Not Shift in Manual Mode" on the [CVT-32, "DIAGNOSTIC WORKSHEET"](#). Continue "Road Test".

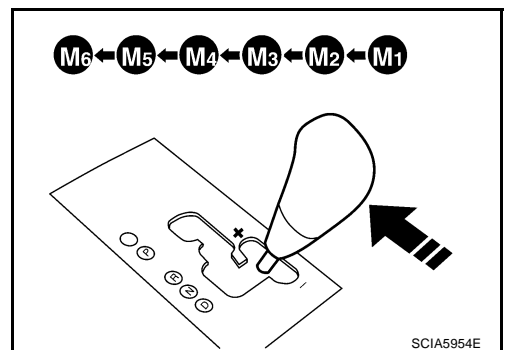

TROUBLE DIAGNOSIS

5. CHECK SHIFT-DOWN FUNCTION

During manual mode driving, is downshift from M6 → M5 → M4 → M3 → M2 → M1 performed?

① Read the gear position. Refer to [CVT-61, "DATA MONITOR MODE"](#).

Is downshifting correctly performed?

YES >> GO TO 6.

NO >> Mark the box of "CVT Does Not Shift in Manual Mode" on the [CVT-32, "DIAGNOSTIC WORKSHEET"](#). Continue "Road Test".

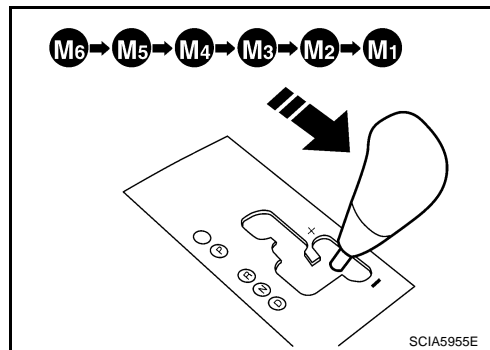

6. CHECK ENGINE BRAKE FUNCTION

Check engine brake.

Does engine braking effectively reduce speed in M1 position?

YES >> 1. Stop the vehicle.

2. Perform self-diagnosis. Refer to [CVT-58, "SELF-DIAGNOSTIC RESULT MODE"](#).

NO >> Mark the box of "Vehicle Does Not Decelerate by Engine Brake" on the [CVT-32, "DIAGNOSTIC WORKSHEET"](#). then continue trouble diagnosis.

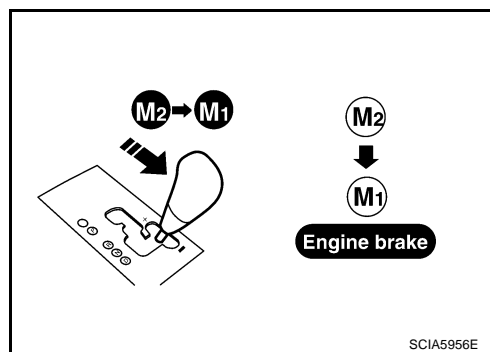

Vehicle Speed at Which Gear Shifting Occurs

Numerical value data are reference values.

Engine type	Throttle position	Shift pattern	Engine speed (rpm)	
			At 40 km/h (25 MPH)	At 60 km/h (37 MPH)
VQ35DE	8/8	"D" position	2,800 - 4,300	3,900 - 5,300
	2/8	"D" position	1,200 - 2,000	1,300 - 2,100

CAUTION:

Lock-up clutch is engaged when vehicle speed is approximately 18 km/h (11 MPH) to 90 km/h (56 MPH).

TROUBLE DIAGNOSIS

TCM Input/Output Signal Reference Values TCM TERMINAL CONNECTOR LAYOUT

EC500F6B

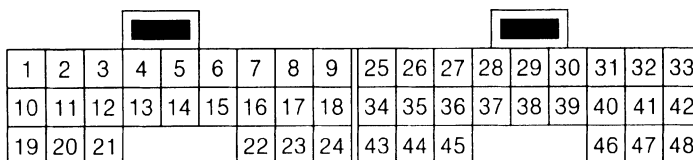













SCIA0495E

TCM INSPECTION TABLE

Data are reference values and are measured between each terminal and ground.

Terminal	Wire color	Item	Condition		Data (Approx.)
1	R/Y	Pressure control solenoid valve A (Line pressure solenoid valve)		Release your foot from the accelerator pedal.	5.0 - 7.0V
				Press the accelerator pedal all the way down.	1.0 - 3.0V
2	W/B	Pressure control solenoid valve B (Secondary pressure solenoid valve)		Release your foot from the accelerator pedal.	5.0 - 7.0V
				Press the accelerator pedal all the way down.	3.0 - 4.0V
3	L/W*1 G*2	Torque converter clutch solenoid valve		When vehicle cruises in "D" position.	When CVT performs lock-up. 6.0V
					When CVT does not perform lock-up. 1.0V
4	L/Y*1 L*2	Lock-up select solenoid valve		Selector lever in "P", "N" positions.	Battery voltage
				Wait at least for 5 seconds with the selector lever in "R", "D" positions.	0V
5	L	CAN H		-	-
6	P	CAN L		-	-
8	SB	Back-up lamp relay		Selector lever in "R" position.	0V
				Selector lever in other positions.	Battery voltage
10	Y	Power supply		—	Battery voltage
					—
11	G/R	Step motor A	Within 2 seconds after ignition switch ON, the time measurement by using the pulse width measurement function (Hi level) of CONSULT-II.*1 CAUTION: Connect the diagnosis data link cable to the vehicle diagnosis connector. *1: A circuit tester cannot be used to test this item.		30.0 msec
12	O/B	Step motor B			10.0 msec
13	G/W	ROM assembly		—	—
14	L/R	ROM assembly		—	—
15	BR/R	ROM assembly		—	—

TROUBLE DIAGNOSIS

Terminal	Wire color	Item	Condition		Data (Approx.)
19	Y	Power supply		—	Battery voltage
				—	0V
20	R	Step motor C	Within 2 seconds after ignition switch ON, the time measurement by using the pulse width measurement function (Hi level) of CONSULT-II.*1		30.0 msec
21	R/G	Step motor D	CAUTION: Connect the diagnosis data link cable to the vehicle diagnosis connector. *1: A circuit tester cannot be used to test this item.		10.0 msec
24	G/O	Starter relay		Selector lever in "N", "P" positions.	Battery voltage
				Selector lever in other positions.	0V
				—	0V
25	B	Ground	Always		0V
27	BR/W	PNP switch 1		Selector lever in "R", "N" and "D" positions.	0V
				Selector lever in "P" position.	Battery voltage
28	Y/R	Power supply (memory back-up)	Always		Battery voltage
29	G ^{*1} LG/R ^{*2}	Output speed sensor (Secondary speed sensor)		When driving ["D" position, 20 km/h (12 MPH)].	300 Hz
32	GR	PNP switch 3 (monitor)		Selector lever in "D" position.	0V
				Selector lever in "P", "R" and "N" positions.	8.0V - Battery voltage
34	P/B	PNP switch 2		Selector lever in "N", "D" positions.	0V
				Selector lever in "P", "R" positions.	10.0V - Battery voltage
35	P/L	PNP switch 3		Selector lever in "D" position.	0V
				Selector lever in "P", "R" and "N" positions.	8.0V - Battery voltage
36	G ^{*1} G/O ^{*2}	PNP switch 4		Selector lever in "R", "D" positions.	0V
				Selector lever in "P", "N" positions.	10.0V - Battery voltage
37	V/W	Transmission fluid pressure sensor A (Secondary pressure sensor)	 and 	"N" position idle	0.8V
38	LG	Input speed sensor (Primary speed sensor)		When driving ["D" position, 20 km/h (12 MPH)].	600 Hz

A

B

CVT

D

E

F

G

H

I





J

K

L

M

TROUBLE DIAGNOSIS

Terminal	Wire color	Item	Condition		Data (Approx.)
41	V/O	Transmission fluid pressure sensor B (Primary pressure sensor)	 and 	"N" position idle	0.7 - 3.5V
42	W/R	Sensor ground	Always		0V
46	L/O	Sensor power		—	4.5 - 5.5V
				—	0V
47	V	CVT fluid temperature sensor		When CVT fluid temperature is 20°C (68°F)	2.0V
				When CVT fluid temperature is 80°C (176°F)	1.0V
48	B	Ground	Always		0V

*1: LHD models.

*2: RHD models.

TROUBLE DIAGNOSIS

CONSULT-II Function (TRANSMISSION)

EC500F6C

CONSULT-II can display each diagnostic item using the diagnostic test modes shown below.

FUNCTION

Diagnostic test mode	Function	Reference page
Work support	This mode enables a technician to adjust some devices faster and more accurately by following the indications on CONSULT-II.	CVT-56
Self-diagnostic results	Self-diagnostic results can be read and erased quickly.	CVT-58
Data monitor	Input/Output data in the TCM can be read.	CVT-61
CAN diagnostic support monitor	The results of transmit/receive diagnosis of CAN communication can be read.	CVT-63
CALIB data	Characteristic information for TCM and CVT assembly can be read. Do not use, but displayed.	—
Function test	Performed by CONSULT-II instead of a technician to determine whether each system is "OK" or "NG".	—
ECU part number	TCM part number can be read.	—

CONSULT-II REFERENCE VALUE

Item name	Condition	Display value (Approx.)
VSP SENSOR	During driving	Approximately matches the speedometer reading.
ESTM VSP SIG		
PRI SPEED SEN	During driving (lock-up ON)	Approximately matches the engine speed.
ENG SPEED SIG	Engine running	Closely matches the tachometer reading.
SEC HYDR SEN	"N" position idle	0.8 - 1.0V
PRI HYDR SEN	"N" position idle	0.7 - 3.5V
ATF TEMP SEN	When CVT fluid temperature is 20°C (68°F)	1.8 - 2.0V
	When CVT fluid temperature is 80°C (176°F)	0.6 - 1.0V
VIGN SEN	Ignition switch: ON	Battery voltage
VEHICLE SPEED	During driving	Approximately matches the speedometer reading.
PRI SPEED	During driving (lock-up ON)	Approximately matches the engine speed.
SEC SPEED	During driving	45 X Approximately matches the speedometer reading.
ENG SPEED	Engine running	Closely matches the tachometer reading.
GEAR RATIO	During driving	2.37 - 0.43
ACC PEDAL OPEN	Released accelerator pedal - Fully depressed accelerator pedal	0.0/8 - 8.0/8
SEC PRESS	"N" position idle	0.5 - 0.9MPa
PRI PRESS	"N" position idle	0.3 - 0.9MPa
STM STEP	During driving	-20 step - 190 step
ISOLT1	Lock-up "OFF"	0.0A
	Lock-up "ON"	0.7A
ISOLT2	Release your foot from the accelerator pedal.	0.8A
	Press the accelerator pedal all the way down.	0.0A
ISOLT3	Secondary pressure low - Secondary pressure high	0.8 - 0.0A
SOLMON1	Lock-up "OFF"	0.0A
	Lock-up "ON"	0.6 - 0.7A

TROUBLE DIAGNOSIS

Item name	Condition	Display value (Approx.)
SOLMON2	"N" position idle	0.8A
	When stalled	0.3 - 0.6A
SOLMON3	"N" position idle	0.6 - 0.7A
	When stalled	0.4 - 0.6A
INH SW3M	Selector lever in "D" position	ON
	Selector lever in "P", "R" and "N" positions	OFF
INH SW4	Selector lever in "R", "D" positions	ON
	Selector lever in "P", "N" positions	OFF
INH SW3	Selector lever in "D" position	ON
	Selector lever in "P", "R" and "N" positions	OFF
INH SW2	Selector lever in "N", "D" positions	ON
	Selector lever in "P", "R" positions	OFF
INH SW1	Selector lever in "R", "N" and "D" positions	ON
	Selector lever in "P" position	OFF
BRAKE SW	Depressed brake pedal	ON
	Released brake pedal	OFF
FULL SW	Fully depressed accelerator pedal	ON
	Released accelerator pedal	OFF
IDLE SW	Released accelerator pedal	ON
	Fully depressed accelerator pedal	OFF
DOWNLVR	Select lever: - side	ON
	Other than the above	OFF
UPLVR	Select lever: + side	ON
	Other than the above	OFF
NON MMODE	Manual shift gate position (neutral, +side, -side)	OFF
	Other than the above	ON
MMODE	Manual shift gate position (neutral)	ON
	Other than the above	OFF
SMCOIL D	During driving	Changes ON ⇔ OFF.
SMCOIL C		
SMCOIL B		
SMCOIL A		
LUSEL SOL OUT	Selector lever in "P", "N" positions	ON
	Wait at least for 5 seconds with the selector lever in "R" or "D" position	OFF
STRTR RLY OUT	Selector lever in "P", "N" positions	ON
	Selector lever in other positions	OFF
STRTR RLY MON	Selector lever in "P", "N" positions	ON
	Selector lever in other positions	OFF
VDC ON	ESP operate	ON
	Other conditions	OFF
TCS ON	TCS operate	ON
	Other conditions	OFF
ABS ON	ABS operate	ON
	Other conditions	OFF

TROUBLE DIAGNOSIS

Item name	Condition	Display value (Approx.)
RANGE	Selector lever in "N" or "P" position	N·P
	Selector lever in "R" position	R
	Selector lever in "D" position	D
M GEAR POS	During driving	1, 2, 3, 4, 5, 6

CONSULT-II SETTING PROCEDURE

CAUTION:

If CONSULT-II is used with no connection of CONSULT-II CONVERTER, malfunctions might be detected in self-diagnosis depending on control unit which performs CAN communication.

- For details, refer to the separate "CONSULT-II Operations Manual".

- Turn ignition switch OFF.
- Connect CONSULT-II and CONSULT-II CONVERTER to data link connector, which is located in instrument driver lower panel on driver side.

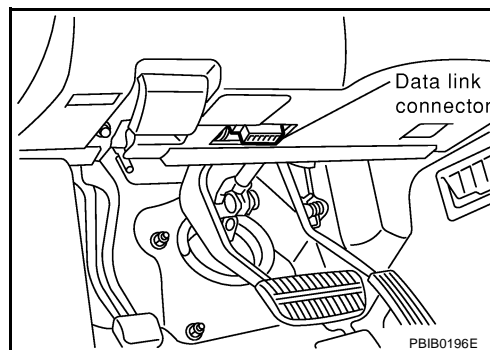

- Turn ignition switch ON. (Do not start engine.)
- Touch "START (NISSAN BASED VHCL)".

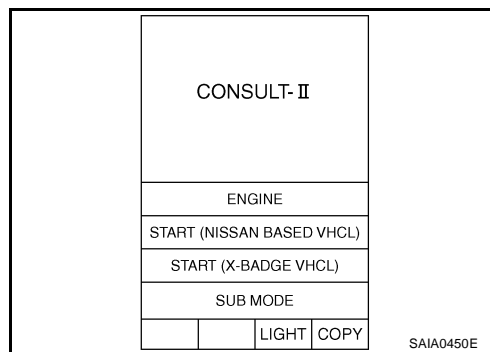

- Touch "TRANSMISSION".
If "TRANSMISSION" is not indicated, go to [GI-35, "CONSULT-II Data Link Connector \(DLC\) Circuit"](#).

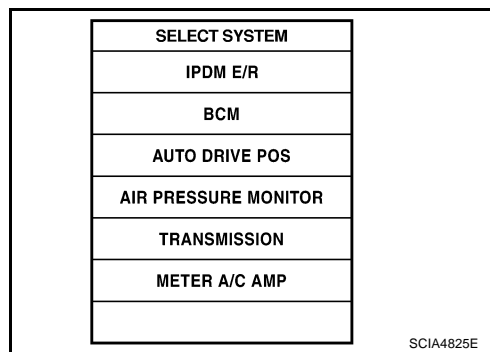

TROUBLE DIAGNOSIS

6. Perform each diagnostic test mode according to each service procedure.

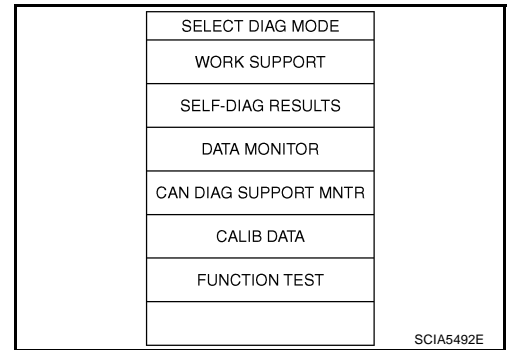

WORK SUPPORT MODE

Display Item List

Item name	Description
ENGINE BRAKE ADJ.	The engine brake level setting can be canceled.
CONFORM CVTF DETERIORTN	The CVT fluid deterioration level can be checked.

Engine Brake Adjustment

1. Perform "CONSULT-II SETTING PROCEDURE". Refer to [CVT-55. "CONSULT-II SETTING PROCEDURE"](#).
2. Touch "WORK SUPPORT".

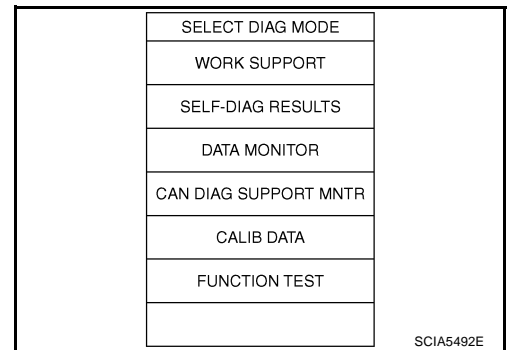

3. Touch "ENGINE BRAKE ADJ".

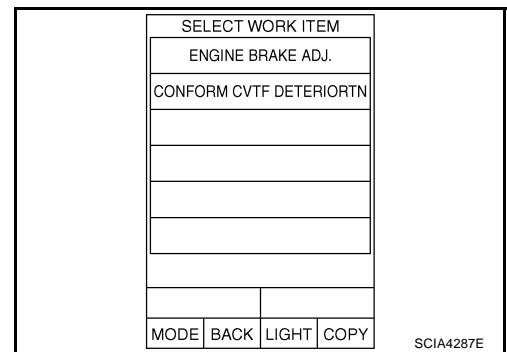

4. Touch "START".

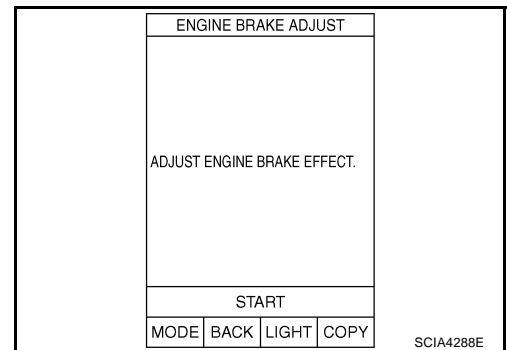

TROUBLE DIAGNOSIS

- Set "ENGINE BRAKE LEVEL" by touching "UP" or "DOWN".

"ENGINE BRAKE LEVEL"

0: Initial set value (Engine brake level control is activated)

OFF: Engine brake level control is deactivated.

- Turn ignition switch OFF, wait at least 5 seconds and then turn ignition switch ON.
- Engine brake level set is completed.

CAUTION:

Mode of "+1" "0" "-1" "-2" "OFF" can be selected by pressing the "UP" "DOWN" on CONSULT-II screen. However, do not select mode other than "0" and "OFF". If the "+1" or "-1" or "-2" is selected, that might cause the irregular driveability.

ENGINE BRAKE ADJ.		
ADJ. MONITOR		
ENGINE BRAKE LEVEL	0	
UP	DOWN	

SAT934J

Check CVT Fluid Deterioration Date

- Perform "CONSULT-II SETTING PROCEDURE". Refer to [CVT-55. "CONSULT-II SETTING PROCEDURE"](#).
- Touch "WORK SUPPORT".

SELECT DIAG MODE
WORK SUPPORT
SELF-DIAG RESULTS
DATA MONITOR
CAN DIAG SUPPORT MNTR
CALIB DATA
FUNCTION TEST

SCIA5492E

- Touch "CONFORM CVTF DETERIORTN".

SELECT WORK ITEM			
ENGINE BRAKE ADJ.			
CONFORM CVTF DETERIORTN			
MODE	BACK	LIGHT	COPY

SCIA4287E

- Check "CVTF DETERIORATION DATE"

"CVTF DETERIORATION DATE"

More than 210000:

It is necessary to change CVT fluid.

Less than 210000:

It is not necessary to change CVT fluid.

CONFORM CVTF DETERIORTN			
CVTF DETERIORATION DATE			
6			
CLEAR	PRINT		
MODE	BACK	LIGHT	COPY

SCIA4289E

TROUBLE DIAGNOSIS

CAUTION:

Touch “CLEAR” after changing CVT fluid, and then erase “CVTF DETERIORATION DATE”.

CONFORM CVTF DETERIORTN			
CVTF DETERIORATION DATE			
0			
CLEAR		PRINT	
MODE	BACK	LIGHT	COPY

SCIA54290E

SELF-DIAGNOSTIC RESULT MODE

After performing self-diagnosis, place check marks for results on the [CVT-32, "DIAGNOSTIC WORKSHEET"](#) . Reference pages are provided following the items.

Operation Procedure

1. Perform “CONSULT-II SETTING PROCEDURE”. Refer to [CVT-55, "CONSULT-II SETTING PROCEDURE"](#) .
2. Touch “SELF-DIAG RESULTS”.
Display shows malfunction experienced since the last erasing operation.

SELECT DIAG MODE
WORK SUPPORT
SELF-DIAG RESULTS
DATA MONITOR
CAN DIAG SUPPORT MNTR
CALIB DATA
FUNCTION TEST

SCIA5492E

Display Items List

X: Applicable —: Not applicable

Items (CONSULT-II screen terms)	Malfunction is detected when...	TCM self-diagnosis	OBD-II (DTC)	Reference page
		“TRANSMISSION” with CONSULT-II	MI*1, “ENGINE” with CONSULT-II or GST	
CAN COMM CIRCUIT	<ul style="list-style-type: none"> When a malfunction is detected in CAN communications 	U1000	U1000	CVT-65
STARTER RELAY/CIRC	<ul style="list-style-type: none"> If this signal is ON other than in “P” or “N” position, this is judged to be a malfunction. (And if it is OFF in “P” or “N” position, this is judged to be a malfunction too.) 	P0615	—	CVT-68
BRAKE SW/CIRC	<ul style="list-style-type: none"> When the brake switch does not switch to ON or OFF 	P0703	—	CVT-72
PNP SW/CIRC	<ul style="list-style-type: none"> PNP switch 1-4 signals input with impossible pattern PNP switch 3 monitor terminal open or short circuit 	P0705	P0705	CVT-74
ATF TEMP SEN/CIRC	<ul style="list-style-type: none"> During running, the CVT fluid temperature sensor signal voltage is excessively high or low 	P0710	P0710	CVT-81
INPUT SPD SEN/CIRC	<ul style="list-style-type: none"> Input speed sensor (primary speed sensor) signal is not input due to an open circuit. An unexpected signal is input when vehicle is being driven. 	P0715	P0715	CVT-86
VEH SPD SEN/CIR AT	<ul style="list-style-type: none"> Signal from vehicle speed sensor CVT [Output speed sensor (Secondary speed sensor)] not input due to open or short circuit Unexpected signal input during running 	P0720	P0720	CVT-91

TROUBLE DIAGNOSIS

Items (CONSULT-II screen terms)	Malfunction is detected when...	TCM self-diagnosis	OBD-II (DTC)	Reference page
		"TRANSMISSION" with CONSULT-II	MI*1, "ENGINE" with CONSULT-II or GST	
ENGINE SPEED SIG	<ul style="list-style-type: none"> ● TCM does not receive the CAN communication signal from the ECM. 	P0725	—	CVT-97
BELT DAMG	<ul style="list-style-type: none"> ● Unexpected gear ratio detected 	P0730	—	CVT-99
TCC SOLENOID/CIRC	<ul style="list-style-type: none"> ● Normal voltage not applied to solenoid due to open or short circuit 	P0740	P0740	CVT-101
A/T TCC S/V FNCTN	<ul style="list-style-type: none"> ● CVT cannot perform lock-up even if electrical circuit is good. ● TCM detects as irregular by comparing difference value with slip rotation. 	P0744	P0744	CVT-106
L/PRESS SOL/CIRC	<ul style="list-style-type: none"> ● Normal voltage not applied to solenoid due to open or short circuit ● TCM detects as irregular by comparing target value with monitor value. 	P0745	P0745	CVT-109
PRS CNT SOL/A FCTN	<ul style="list-style-type: none"> ● Unexpected gear ratio was detected in the LOW side due to excessively low line pressure. 	P0746	P0746	CVT-114
PRS CNT SOL/B FCTN	<ul style="list-style-type: none"> ● Secondary pressure is too high or too low compared with the commanded value while driving. 	P0776	P0776	CVT-117
PRS CNT SOL/B CIRC	<ul style="list-style-type: none"> ● Normal voltage not applied to solenoid due to cut line, short, or the like ● TCM detects as irregular by comparing target value with monitor value. 	P0778	P0778	CVT-120
MANUAL MODE SWITCH	<ul style="list-style-type: none"> ● When an impossible pattern of switch signals is detected, a malfunction is detected. 	P0826	—	CVT-125
TR PRS SENS/A CIRC	<ul style="list-style-type: none"> ● Signal voltage of the transmission fluid pressure sensor A (secondary pressure sensor) is too high or too low while driving. 	P0840	P0840	CVT-132
PRESS SEN/FNCTN	<ul style="list-style-type: none"> ● Correlation between the values of the transmission fluid pressure sensor A (secondary pressure sensor) and the transmission fluid pressure sensor B (primary pressure sensor) is out of specification. 	P0841	—	CVT-137
TR PRS SENS/B CIRC	<ul style="list-style-type: none"> ● Signal voltage of the transmission fluid pressure sensor B (primary pressure sensor) is too high or too low while driving. 	P0845	P0845	CVT-140
SEC/PRESS DOWN	<ul style="list-style-type: none"> ● Secondary fluid pressure is too low compared with the commanded value while driving. 	P0868	—	CVT-145
TCM-POWER SUPPLY	<ul style="list-style-type: none"> ● When the power supply to the TCM is cut OFF, for example because the battery is removed, and the self-diagnosis memory function stops ● This is not a malfunction message (Whenever shutting OFF a power supply to the TCM, this message appears on the screen.) 	P1701	—	CVT-148
TP SEN/CIRC A/T	<ul style="list-style-type: none"> ● TCM does not receive the proper accelerator pedal position signals (input by CAN communication) from ECM. 	P1705	—	CVT-155
ESTM VEH SPD SIG	<ul style="list-style-type: none"> ● CAN communication with the ABS actuator and the electric unit (control unit) is malfunctioning. ● There is a great difference between the vehicle speed signal from the ABS actuator and the electric unit (control unit), and the vehicle speed sensor signal. 	P1722	—	CVT-157

A
B
CVT
D
E
F
G
H
I
J
K
L
M

TROUBLE DIAGNOSIS

Items (CONSULT-II screen terms)	Malfunction is detected when...	TCM self-diagnosis	OBD-II (DTC)	Reference page
		"TRANSMISSION" with CONSULT-II	MI*1, "ENGINE" with CONSULT-II or GST	
CVT SPD SEN/ FNCTN	<ul style="list-style-type: none"> A rotation sensor error is detected because the gear does not change in accordance with the position of the stepping motor. <p>CAUTION: One of the "P0720 VEH SPD SEN/CIR AT", the "P0715 INPUT SPD SEN/CIRC" or the "P0725 ENGINE SPEED SIG" is displayed with the DTC at the same time.</p>	P1723	—	CVT-159
ELEC TH CONTROL	<ul style="list-style-type: none"> The electronically controlled throttle for ECM is malfunctioning. 	P1726	—	CVT-161
LU-SLCT SOL/ CIRC	<ul style="list-style-type: none"> Normal voltage not applied to solenoid due to cut line, short, or the like TCM detects as irregular by comparing target value with monitor value. 	P1740	P1740	CVT-163
L/PRESS CONTROL	<ul style="list-style-type: none"> TCM detects the unexpected line pressure. 	P1745	—	CVT-168
STEP MOTR CIRC	<ul style="list-style-type: none"> Each coil of the step motor is not energized properly due to an open or a short. 	P1777	P1777	CVT-169
STEP MOTR/FNC	<ul style="list-style-type: none"> There is a great difference between the number of steps for the stepping motor and for the actual gear ratio. 	P1778	P1778	CVT-173
NO DTC IS DETECTED: FURTHER TESTING MAY BE REQUIRED	<ul style="list-style-type: none"> No NG item has been detected. 	X	X	—

*1: Refer to [CVT-28. "Malfunction Indicator \(MI\)"](#) .

How to Erase Self-diagnostic Results

- Perform "CONSULT-II SETTING PROCEDURE". Refer to [CVT-55. "CONSULT-II SETTING PROCEDURE"](#) .
- Touch "SELF-DIAG RESULTS".

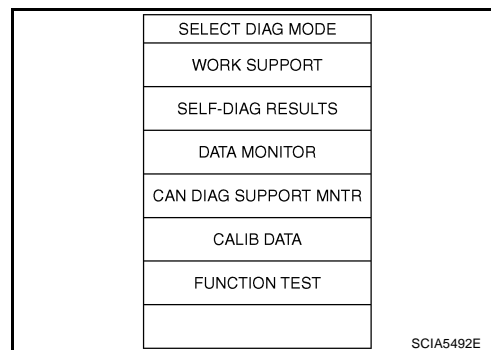

- Touch "ERASE". (The self-diagnostic results will be erased.)

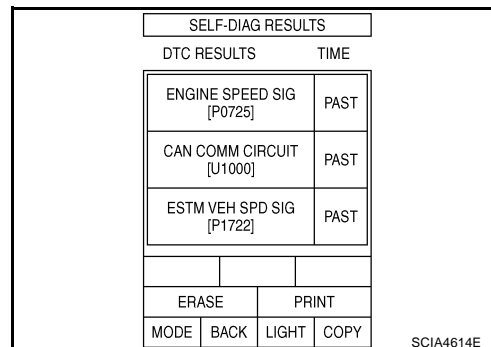

TROUBLE DIAGNOSIS

DATA MONITOR MODE

Operation Procedure

1. Perform "CONSULT-II SETTING PROCEDURE". Refer to [CVT-55, "CONSULT-II SETTING PROCEDURE"](#).
2. Touch "DATA MONITOR".

NOTE:

When malfunction is detected, CONSULT-II performs "REAL-TIME DIAGNOSIS". Also, any malfunction detected while in this mode will be displayed at real time.

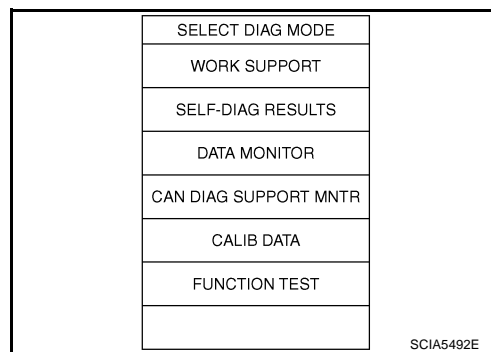

Display Items List

X: Standard, —: Not applicable, ▼: Option

Monitored item (Unit)	Monitor item selection			Remarks
	ECU INPUT SIGNALS	MAIN SIGNALS	SELECTION FROM MENU	
VSP SENSOR (km/h)	X	—	▼	Output speed sensor (secondary speed sensor).
ESTM VSP SIG (km/h)	X	—	▼	
PRI SPEED SEN (rpm)	X	—	▼	
ENG SPEED SIG (rpm)	X	—	▼	
SEC HYDR SEN (V)	X	—	▼	
PRI HYDR SEN (V)	X	—	▼	
ATF TEMP SEN (V)	X	—	▼	CVT fluid temperature sensor
VIGN SEN (V)	X	—	▼	
VEHICLE SPEED (km/h)	—	X	▼	Vehicle speed recognized by the TCM.
PRI SPEED (rpm)	—	X	▼	Primary pulley speed.
SEC SPEED (rpm)	—	—	▼	Secondary pulley speed.
ENG SPEED (rpm)	—	X	▼	
SLIP REV (rpm)	—	X	▼	Difference between engine speed and primary pulley speed
GEAR RATIO	—	X	▼	
G SPEED (G)	—	—	▼	
ACC PEDAL OPEN (0.0/8)	X	X	▼	Degree of opening for accelerator recognized by the TCM For fail-safe operation, the specific value used for control is displayed.
TRQ RTO	—	—	▼	
SEC PRESS (MPa)	—	X	▼	
PRI PRESS (MPa)	—	X	▼	
ATF TEMP	—	X	▼	
DSR REV (rpm)	—	—	▼	
DGEAR RATIO	—	—	▼	

TROUBLE DIAGNOSIS

Monitored item (Unit)	Monitor item selection			Remarks
	ECU INPUT SIGNALS	MAIN SIGNALS	SELECTION FROM MENU	
DSTM STEP (step)	—	—	▼	
STM STEP (step)	—	X	▼	
LU PRS (MPa)	—	—	▼	
LINE PRS (MPa)	—	—	▼	
TGT SEC PRESS (MPa)	—	—	▼	
ISOLT1 (A)	—	X	▼	Torque converter clutch solenoid valve output current
ISOLT2 (A)	—	X	▼	Pressure control solenoid valve A (line pressure solenoid valve) output current
ISOLT3 (A)	—	X	▼	Pressure control solenoid valve B (secondary pressure solenoid valve) output current
SOLMON1 (A)	X	X	▼	Torque converter clutch solenoid valve monitor current
SOLMON2 (A)	X	X	▼	Pressure control solenoid valve A (line pressure solenoid valve) monitor current
SOLMON3 (A)	X	X	▼	Pressure control solenoid valve B (secondary pressure solenoid valve) monitor current
INH SW3M (ON/OFF)	X	—	▼	PNP switch 3 ON-OFF status monitor
INH SW4 (ON/OFF)	X	—	▼	PNP switch 4 ON-OFF status
INH SW3 (ON/OFF)	X	—	▼	PNP switch 3 ON-OFF status
INH SW2 (ON/OFF)	X	—	▼	PNP switch 2 ON-OFF status
INH SW1 (ON/OFF)	X	—	▼	PNP switch 1 ON-OFF status
BRAKE SW (ON/OFF)	X	X	▼	Stop lamp switch
FULL SW (ON/OFF)	X	X	▼	Signal input with CAN communications
IDLE SW (ON/OFF)	X	X	▼	
SPORT MODE SW (ON/OFF)	X	X	▼	Not mounted but displayed.
STRDWNSW (ON/OFF)	X	—	▼	
STRUPSW (ON/OFF)	X	—	▼	
DOWNLVR (ON/OFF)	X	—	▼	
UPLVR (ON/OFF)	X	—	▼	
NON MMODE (ON/OFF)	X	—	▼	
MMODE (ON/OFF)	X	—	▼	
INDLRNG (ON/OFF)	—	—	▼	
INDDRNG (ON/OFF)	—	—	▼	“D” position indicator output
INDNRNG (ON/OFF)	—	—	▼	“N” position indicator output
INDRRNG (ON/OFF)	—	—	▼	“R” position indicator output
INDPRNG (ON/OFF)	—	—	▼	“P” position indicator output
CVTLAMP (ON/OFF)	—	—	▼	

TROUBLE DIAGNOSIS

Monitored item (Unit)	Monitor item selection			Remarks
	ECU INPUT SIGNALS	MAIN SIGNALS	SELECTION FROM MENU	
SPORT MODE IND (ON/OFF)	—	—	▼	Not mounted but displayed.
MMODE IND (ON/OFF)	—	—	▼	
SMCOIL D (ON/OFF)	—	—	▼	Step motor coil "D" energizing status
SMCOIL C (ON/OFF)	—	—	▼	Step motor coil "C" energizing status
SMCOIL B (ON/OFF)	—	—	▼	Step motor coil "B" energizing status
SMCOIL A (ON/OFF)	—	—	▼	Step motor coil "A" energizing status
LUSEL SOL OUT (ON/OFF)	—	—	▼	
REV LAMP (ON/OFF)	—	X	▼	
STRTR RLY OUT (ON/OFF)	—	—	▼	Starter relay
LUSEL SOL MON (ON/OFF)	—	—	▼	
STRTR RLY MON (ON/OFF)	—	—	▼	Starter relay
VDC ON (ON/OFF)	X	—	▼	ESP (Electronic Stability Program)
TCS ON (ON/OFF)	X	—	▼	
ABS ON (ON/OFF)	X	—	▼	
ACC ON (ON/OFF)	X	—	▼	Not mounted but displayed.
RANGE	—	X	▼	Indicates position is recognized by TCM. Indicates a specific value required for control when fail-safe function is activated.
M GEAR POS	—	X	▼	
Voltage (V)	—	—	▼	Displays the value measured by the voltage probe.
Frequency (Hz)	—	—	▼	The value measured by the pulse probe is displayed.
DUTY-HI (high) (%)	—	—	▼	
DUTY-LOW (low) (%)	—	—	▼	
PLS WIDTH-HI (ms)	—	—	▼	
PLS WIDTH-LOW (ms)	—	—	▼	

CAN DIAGNOSTIC SUPPORT MONITOR MODE

Operation Procedure

1. Perform "CONSULT-II SETTING PROCEDURE". Refer to [CVT-55, "CONSULT-II SETTING PROCEDURE"](#).
2. Touch "CAN DAIG SUPPORT MNTR". Refer to [LAN-3, "Precautions When Using CONSULT-II"](#).

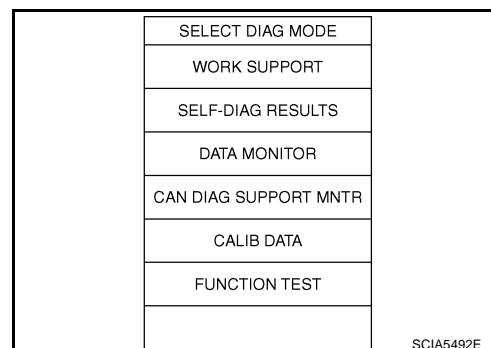

TROUBLE DIAGNOSIS

Diagnostic Procedure Without CONSULT-II **OBD-II SELF-DIAGNOSTIC PROCEDURE (WITH GST)**

ECS00F6D

Refer to [EC-109, "Generic Scan Tool \(GST\) Function"](#) .

DTC U1000 CAN COMMUNICATION LINE

DTC U1000 CAN COMMUNICATION LINE

PFP:23710

Description

ECS00F6E

CAN (Controller Area Network) is a serial communication line for real time application. It is an on-vehicle multiplex communication line with high data communication speed and excellent malfunction detection ability. Many electronic control units are equipped onto a vehicle, and each control unit shares information and links with other control units during operation (not independent). In CAN communication, control units are connected with 2 communication lines (CAN H line, CAN L line) allowing a high rate of information transmission with less wiring. Each control unit transmits/receives data but selectively reads required data only.

On Board Diagnosis Logic

ECS00F6F

- This is an OBD-II self-diagnostic item.
- Diagnostic trouble code "U1000 CAN COMM CIRCUIT" with CONSULT-II is detected when TCM cannot communicate to other control units.

Possible Cause

ECS00F6G

Harness or connectors
(CAN communication line is open or shorted.)

DTC Confirmation Procedure

ECS00F6H

NOTE:

If "DTC Confirmation Procedure" has been previously performed, always turn ignition switch OFF and wait at least 10 seconds before performing the next test.

After the repair, touch "ERASE" on "SELF-DIAG RESULTS" and then perform the following procedure to confirm the malfunction is eliminated.

Ⓟ WITH CONSULT-II

1. Turn ignition switch ON. (Do not start engine.)
2. Select "DATA MONITOR" mode for "TRANSMISSION" with CONSULT-II.
3. Start engine and wait for at least 6 seconds.
4. If DTC is detected, go to [CVT-67, "Diagnostic Procedure"](#) .

SELECT SYSTEM
IPDM E/R
BCM
AUTO DRIVE POS
AIR PRESSURE MONITOR
TRANSMISSION
METER A/C AMP

SCIA4825E

Ⓢ WITH GST



Follow the procedure "WITH CONSULT-II".

DTC U1000 CAN COMMUNICATION LINE

Wiring Diagram — CVT — CAN

ECS00F6I

CVT-CAN-01

-  : DETECTABLE LINE FOR DTC
-  : NON-DETECTABLE LINE FOR DTC
-  : DATA LINE

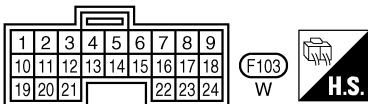
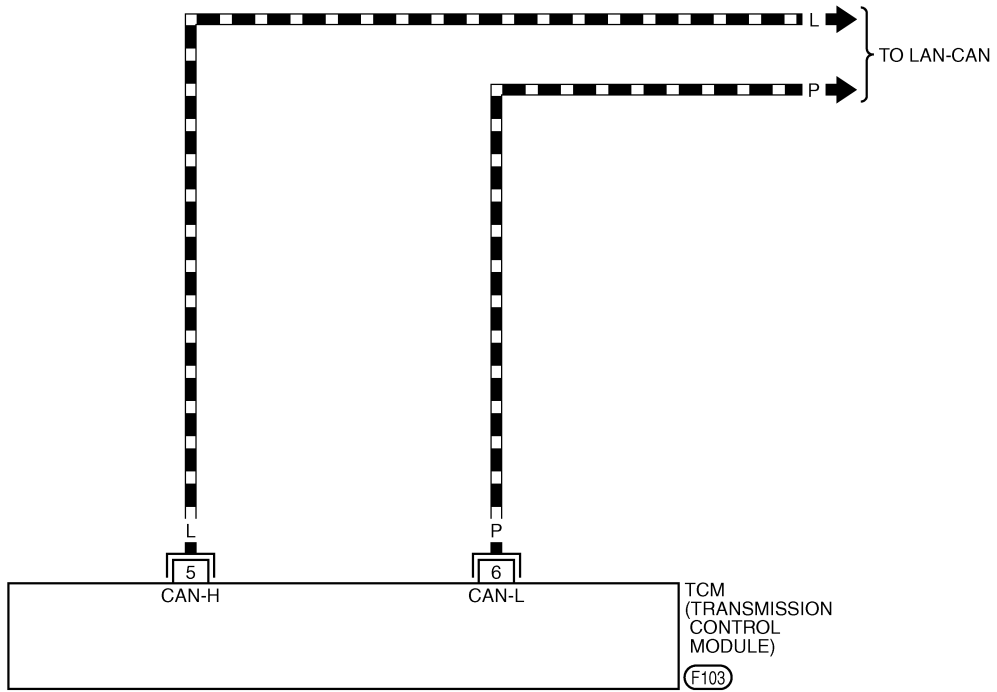

TCWB0136E

DTC U1000 CAN COMMUNICATION LINE

TCM terminal data are reference values, measured between each terminal and ground.

Terminal	Wire color	Item	Condition	Data (Approx.)
5	L	CAN H	-	-
6	P	CAN L	-	-

Diagnostic Procedure

ECS00F6J

1. CHECK CAN COMMUNICATION CIRCUIT

④ With CONSULT-II

- Turn ignition switch ON and start engine.
- Select "SELF-DIAG RESULTS" mode for "TRANSMISSION" with CONSULT-II.

Is any malfunction of the "U1000 CAN COMM CIRCUIT" indicated?

YES >> Print out CONSULT-II screen, GO TO LAN section.
Refer to [LAN-3, "Precautions When Using CONSULT-II"](#)

NO >> **INSPECTION END**

SELF-DIAG RESULTS			
DTC RESULTS		TIME	
CAN COMM CIRCUIT [U1000]		PAST	
ERASE		PRINT	
MODE	BACK	LIGHT	COPY

SCIA5982E

A

B

CVT

D

E

F

G

H

I

J

K

L

M

DTC P0615 START SIGNAL CIRCUIT

DTC P0615 START SIGNAL CIRCUIT

PFP:25230

Description

ECS00F6K

- TCM controls starter relay in IPDM E/R.
- TCM switches starter relay ON at “P” or “N” position and allows to crank engine.
- Then it prohibits cranking other than at “P” or “N” position.

CONSULT-II Reference Value

ECS00F6L

Remarks: Specification data are reference values.

Item name	Condition	Display value
STRTR RLY OUT	Selector lever in “P”, “N” positions.	ON
	Selector lever in other positions.	OFF
STRTR RLY MON	Selector lever in “P”, “N” positions.	ON
	Selector lever in other positions.	OFF

On Board Diagnosis Logic

ECS00F6M

- This is not an OBD-II self-diagnostic item.
- Diagnostic trouble code “P0615 STARTER RELAY/CIRC” with CONSULT-II is detected when starter relay switched ON other than at “P” or “N” position. (Or when switched OFF at “P” or “N” position).

Possible Cause

ECS00F6N

- Harness or connectors
(Starter relay and TCM circuit is open or shorted.)
- Starter relay

DTC Confirmation Procedure

ECS00F6O

CAUTION:

Always drive vehicle at a safe speed.

NOTE:

If “DTC Confirmation Procedure” has been previously performed, always turn ignition switch OFF and wait at least 10 seconds before performing the next test.

After the repair, touch “ERASE” on “SELF-DIAG RESULTS” and then perform the following procedure to confirm the malfunction is eliminated.

④ WITH CONSULT-II

1. Turn ignition switch ON. (Do not start engine.)
2. Select “DATA MONITOR” mode for “TRANSMISSION” with CONSULT-II.
3. Start engine.
4. Drive vehicle for at least 2 consecutive seconds.
5. If DTC is detected, go to [CVT-70, "Diagnostic Procedure"](#) .

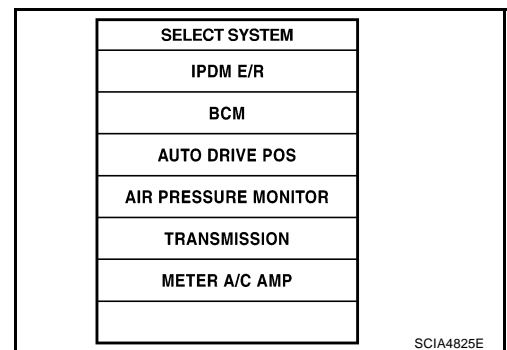

DTC P0615 START SIGNAL CIRCUIT

Wiring Diagram — CVT — STSIG

ECS00F6P

CVT-STSIG-01

- : DETECTABLE LINE FOR DTC
- : NON-DETECTABLE LINE FOR DTC
- (L)** : LHD MODELS
- (R)** : RHD MODELS
- *1 2: **(L)**
- 7: **(R)**

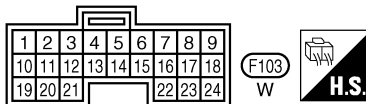
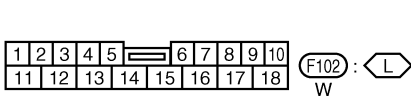
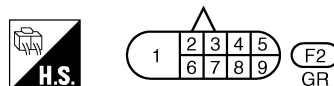
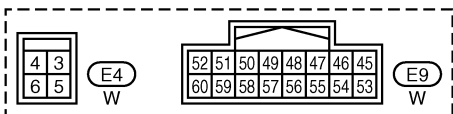
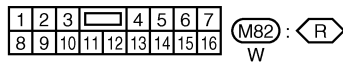
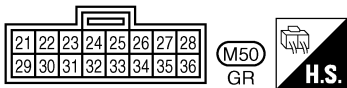
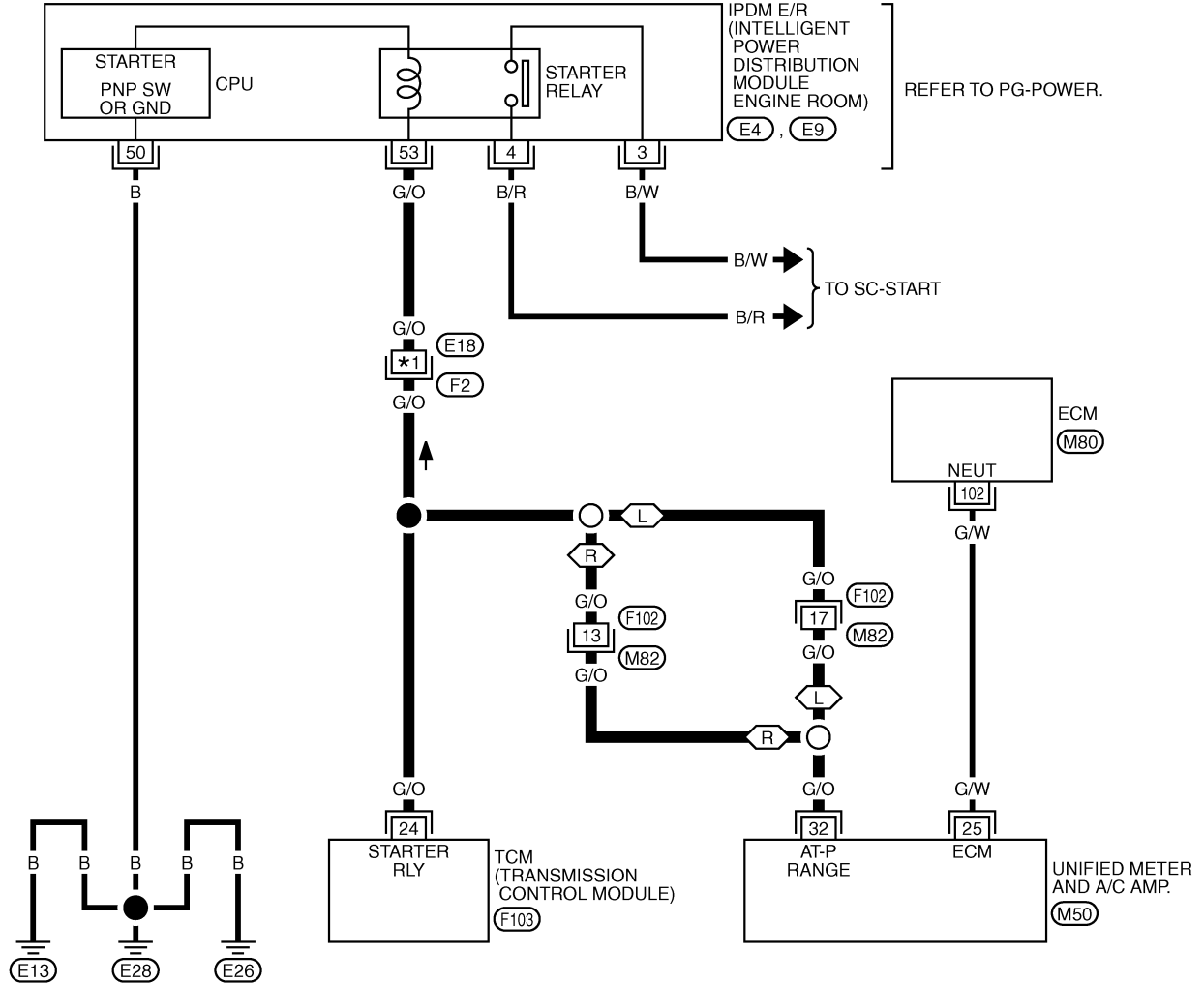

REFER TO THE FOLLOWING.
(M80) -ELECTRICAL UNITS

TCWB0137E

DTC P0615 START SIGNAL CIRCUIT

TCM terminal data are reference values, measured between each terminal and ground.

Terminal	Wire color	Item	Condition	Data (Approx.)
24	G/O	Starter relay	 Selector lever in "N", "P" positions.	Battery voltage
			Selector lever in other positions.	0V

Diagnostic Procedure

ECS00F6Q

1. CHECK STARTER RELAY

With CONSULT-II

- Turn ignition switch ON. (Do not start engine.)
- Select "SELECTION FROM MENU" in "DATA MONITOR" mode for "TRANSMISSION" with CONSULT-II and check monitor "STRTR RLY OUT", "STRTR RLY MON"(PNP relay) ON/OFF.

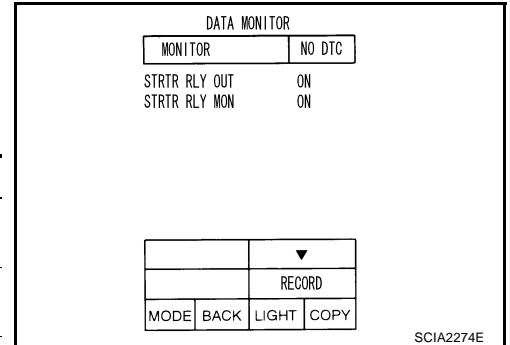

Item name	Condition	Display value
STRTR RLY OUT	Selector lever in "P", "N" positions.	ON
	Selector lever in other positions.	OFF
STRTR RLY MON	Selector lever in "P", "N" positions.	ON
	Selector lever in other positions.	OFF

Without CONSULT-II

- Turn ignition switch ON. (Do not start engine.)
- Check voltage between the TCM connector terminal and ground.

Terminal	Item	Condition	Data (Approx.)
24	Starter relay	 Selector lever in "N", "P" positions.	Battery voltage
		Selector lever in other positions.	0V

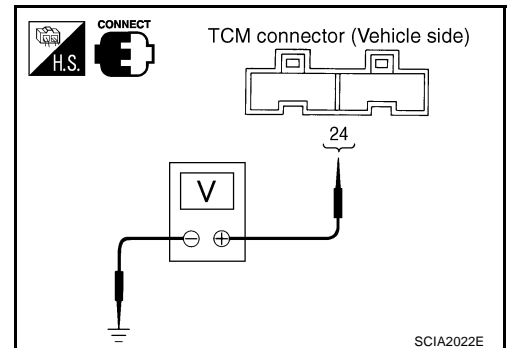

OK or NG

- OK >> GO TO 3.
 NG >> GO TO 2.

2. DETECT MALFUNCTIONING ITEM

Check the following:

- Starter relay. Refer to [PG-108, "STANDARDIZED RELAY"](#) .
- Open or short-circuit in the harness between TCM and the stater relay. Refer to [CVT-69, "Wiring Diagram — CVT — STSIG"](#) .
- Ground circuit for the starter relay. Refer to [SC-14, "Wiring Diagram — START —"](#) .

OK or NG

- OK >> GO TO 3.
 NG >> Repair or replace damaged parts.

DTC P0615 START SIGNAL CIRCUIT

3. CHECK DTC

Perform "DTC Confirmation Procedure". Refer to [CVT-68, "DTC Confirmation Procedure"](#) .

OK or NG

OK >> **INSPECTION END**
NG >> GO TO 4.

4. CHECK TCM

1. Check TCM input/output signal. Refer to [CVT-50, "TCM Input/Output Signal Reference Values"](#) .
2. If NG, re-check TCM pin terminals for damage or loose connection with harness connector.

OK or NG

OK >> **INSPECTION END**
NG >> Repair or replace damaged parts.

A

B

CVT

D

E

F

G

H

I

J

K

L

M

DTC P0703 STOP LAMP SWITCH CIRCUIT

DTC P0703 STOP LAMP SWITCH CIRCUIT

PFP:25320

Description

ECS00F6R

ON, OFF status of the stop lamp switch is sent via the CAN communication from the unified meter and A/C amp to TCM using the signal.

CONSULT-II Reference Value

ECS00F6S

Remarks: Specification data are reference values.

Item name	Condition	Display value
BRAKE SW	Depressed brake pedal	ON
	Released brake pedal	OFF

On Board Diagnosis Logic

ECS00F6T

- This is not an OBD-II self-diagnostic item.
- Diagnostic trouble code "P0703 BRAKE SW/CIRC" with CONSULT-II is detected when the stop lamp switch does not switch to ON and OFF.
- The stop lamp switch does not switch to ON and OFF.

Possible Cause

ECS00F6U

- Harness or connectors
(Stop lamp switch, and unified meter and A/C amp circuit are open or shorted.)
(CAN communication line is open or shorted.)
- Stop lamp switch

DTC Confirmation Procedure

ECS00F6V

CAUTION:

Always drive vehicle at a safe speed.

NOTE:

If "DTC Confirmation Procedure" has been previously performed, always turn ignition switch OFF and wait at least 10 seconds before performing the next test.

After the repair, touch "ERASE" on "SELF-DIAG RESULTS" and then perform the following procedure to confirm the malfunction is eliminated.

WITH CONSULT-II

1. Turn ignition switch ON. (Do not start engine.)
2. Select "DATA MONITOR" mode for "TRANSMISSION" with CONSULT-II.
3. Start engine.
4. Start vehicle for at least 3 consecutive seconds.
5. If DTC is detected, go to [CVT-73, "Diagnostic Procedure"](#) .

SELECT SYSTEM
IPDM E/R
BCM
AUTO DRIVE POS
AIR PRESSURE MONITOR
TRANSMISSION
METER A/C AMP

SCIA4825E

DTC P0703 STOP LAMP SWITCH CIRCUIT

EC500F6W

Diagnostic Procedure

1. CHECK CAN COMMUNICATION LINE

Perform the self-diagnosis check. Refer to [CVT-58, "SELF-DIAGNOSTIC RESULT MODE"](#).

Is any malfunction of the "U1000 CAN COMM CIRCUIT" indicated?

- YES >> Check CAN communication line. Refer to [CVT-65, "DTC U1000 CAN COMMUNICATION LINE"](#).
 NO >> GO TO 2.

2. CHECK STOP LAMP SWITCH CIRCUIT

With CONSULT-II

- Turn ignition switch ON. (Do not start engine.)
- Select "ECU INPUT SIGNALS" in "DATA MONITOR" mode for "TRANSMISSION" with CONSULT-II.
- Read out ON/OFF switching action of the "BRAKE SW".

Item name	Condition	Display value
BRAKE SW	Depressed brake pedal	ON
	Released brake pedal	OFF

DATA MONITOR			
MONITOR		NO DTC	
INH SW 4		OFF	
INH SW 3		OFF	
INH SW 2		OFF	
INH SW 1		OFF	
BRAKE SW		OFF	
		▽	
RECORD			
MODE	BACK	LIGHT	COPY

SCIA2275E

OK or NG

- OK >> **INSPECTION END**
 NG >> GO TO 3.

3. CHECK STOP LAMP SWITCH

Check continuity between stop lamp switch harness connector terminals 1 and 2. Refer to [CVT-176, "Wiring Diagram — CVT — NONDTC \(LHD Models\)"](#), [CVT-180, "Wiring Diagram — CVT — NONDTC \(RHD Models\)"](#).

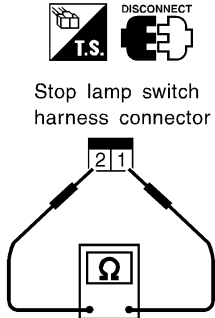

T.S. DISCONNECT

Stop lamp switch harness connector

Condition	Continuity
When brake pedal is depressed	Yes
When brake pedal is released	No

SCIA3700E

Check stop lamp switch after adjusting brake pedal — refer to [BR-6, "BRAKE PEDAL"](#).

OK or NG

- OK >> Check the following. If NG, repair or replace damaged parts.
- Harness for short or open between battery and stop lamp switch.
 - Harness for short or open between stop lamp switch and unified meter and A/C amp.
- NG >> Repair or replace the stop lamp switch.

DTC P0705 PARK/NEUTRAL POSITION SWITCH

DTC P0705 PARK/NEUTRAL POSITION SWITCH

PFP:32006

Description

ECS00F6X

- The park/neutral position (PNP) switch includes 4 transmission position switches.
- TCM judges the selector lever position by the PNP switch signal.

Shift position	PNP switch 1	PNP switch 2	PNP switch 3	PNP switch 4	PNP switch 3 (monitor)
P	OFF	OFF	OFF	OFF	OFF
R	ON	OFF	OFF	ON	OFF
N	ON	ON	OFF	OFF	OFF
D	ON	ON	ON	ON	ON

CONSULT-II Reference Value

ECS00F6Y

Remarks: Specification data are reference values.

Item name	Condition	Display value
INH SW3M	Selector lever in "D" position.	ON
	Selector lever in "P", "R" and "N" positions.	OFF
INH SW4	Selector lever in "R", "D" positions.	ON
	Selector lever in "P", "N" positions.	OFF
INH SW3	Selector lever in "D" position.	ON
	Selector lever in "P", "R" and "N" positions.	OFF
INH SW2	Selector lever in "N", "D" positions.	ON
	Selector lever in "P", "R" positions.	OFF
INH SW1	Selector lever in "R", "N" and "D" positions.	ON
	Selector lever in "P" position.	OFF

On Board Diagnosis Logic

ECS00F6Z

- This is an OBD-II self-diagnostic item.
- Diagnostic trouble code "P0705 PNP SW/CIRC" with CONSULT-II is detected under the following conditions.
 - When TCM does not receive the correct voltage signal from the PNP switches 1, 2, 3 and 4 based on the gear position.
 - When the signal from monitor terminal of PNP switch 3 is different from PNP switch 3.

Possible Cause

ECS00F70

- Harness or connectors
[Park/neutral position (PNP) switches 1, 2, 3, 4 and TCM circuit is open or shorted.]
- Park/neutral position (PNP) switches 1, 2, 3 and 4
- Park/neutral position (PNP) switch 3 monitor terminal is open or shorted

DTC Confirmation Procedure

ECS00F71

CAUTION:

Always drive vehicle at a safe speed.

NOTE:

If "DTC Confirmation Procedure" has been previously performed, always turn ignition switch OFF and wait at least 10 seconds before performing the next test.

After the repair, touch "ERASE" on "SELF-DIAG RESULTS" and then perform the following procedure to confirm the malfunction is eliminated.

DTC P0705 PARK/NEUTRAL POSITION SWITCH

WITH CONSULT-II

1. Turn ignition switch ON. (Do not start engine.)
2. Select "DATA MONITOR" mode for "ENGINE" with CONSULT-II.
3. Start engine.
4. Drive vehicle and maintain the following conditions for at least 2 consecutive seconds.
VHCL SPEED SE: More than 10 km/h (6 MPH)
ENG SPEED SIG: More than 450 rpm
ACC PEDAL OPEN: More than 1/8
5. If DTC is detected, go to [CVT-78, "Diagnostic Procedure"](#) .

SELECT SYSTEM
ENGINE
ABS
AIR BAG
ALL MODE AWD/4WD
IPDM E/R
BCM

SCIA4823E

WITH GST

Follow the procedure "WITH CONSULT-II".

A
B
CVT
D
E
F
G
H
I
J
K
L
M

DTC P0705 PARK/NEUTRAL POSITION SWITCH

Wiring Diagram — CVT — PNP/SW

ECS00F72

CVT-PNP/SW-01

- : DETECTABLE LINE FOR DTC
- : NON-DETECTABLE LINE FOR DTC
- L** : LHD MODELS
- R** : RHD MODELS

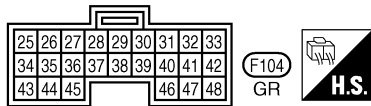
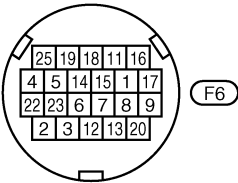
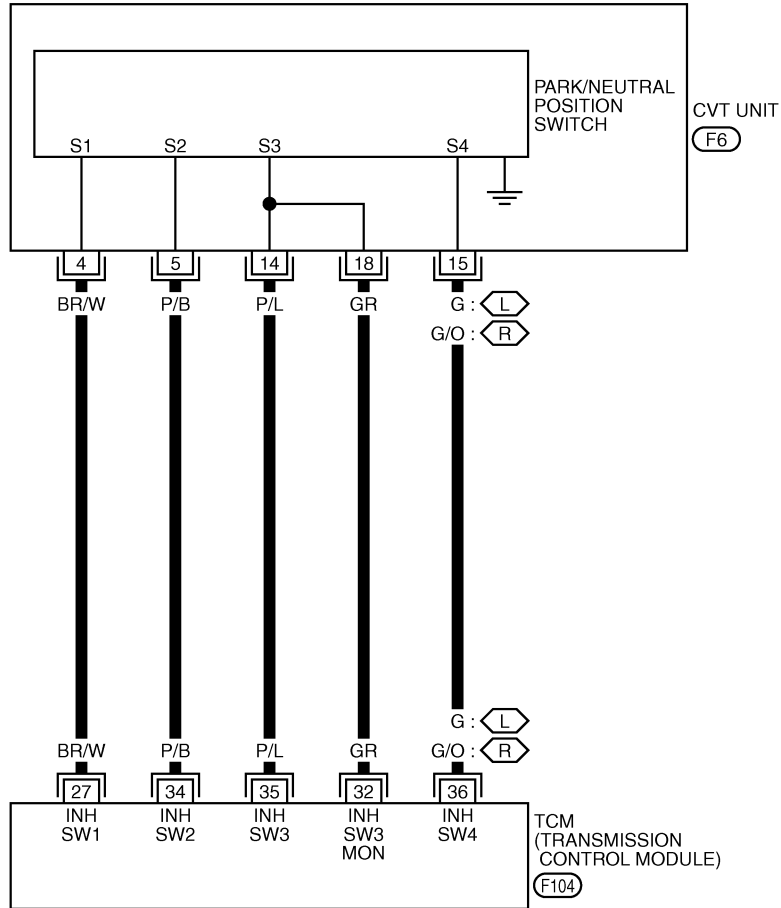

TCWB0138E

DTC P0705 PARK/NEUTRAL POSITION SWITCH

TCM terminal data are reference values, measured between each terminal and ground.

Terminal	Wire color	Item	Condition	Data (Approx.)
27	BR/W	PNP switch 1	Selector lever in "R", "N" and "D" positions.	0V
			Selector lever in "P" position.	Battery voltage
32	GR	PNP switch 3 (monitor)	Selector lever in "D" position.	0V
			Selector lever in "P", "R" and "N" positions.	8.0V - Battery voltage
34	P/B	PNP switch 2	Selector lever in "N", "D" positions.	0V
			Selector lever in "P", "R" positions.	10.0V - Battery voltage
35	P/L	PNP switch 3	Selector lever in "D" position.	0V
			Selector lever in "P", "R" and "N" positions.	8.0V - Battery voltage
36	G ^{*1} G/O ^{*2}	PNP switch 4	Selector lever in "R", "D" positions.	0V
			Selector lever in "P", "N" positions.	10.0V - Battery voltage



*1: LHD models.

*2: RHD models.

A
B
CVT
D
E
F
G
H
I
J
K
L
M

DTC P0705 PARK/NEUTRAL POSITION SWITCH

ECS00F73

Diagnostic Procedure

1. CHECK PNP SW CIRCUIT

With CONSULT-II

- Turn ignition switch ON. (Do not start engine.)
- Select "ECU INPUT SIGNALS" in "DATA MONITOR" mode for "TRANSMISSION" with CONSULT-II.
- Selector lever to "P", "R", "N" and "D" position to check the value of "INH SW1", "INH SW2", "INH SW3", "INH SW4" and "INH SW3M".

Shift position	"INH SW1"	"INH SW2"	"INH SW3"	"INH SW4"	"INH SW3M"
P	OFF	OFF	OFF	OFF	OFF
R	ON	OFF	OFF	ON	OFF
N	ON	ON	OFF	OFF	OFF
D	ON	ON	ON	ON	ON

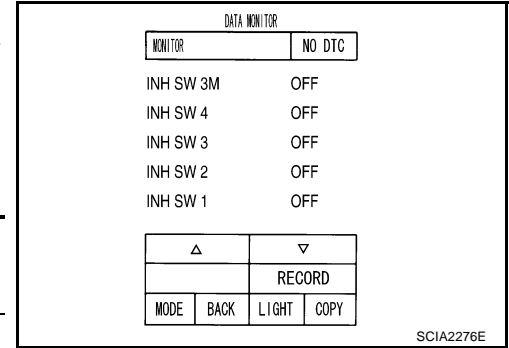

Without CONSULT-II

- Turn ignition switch ON. (Do not start engine.)
- Change selector lever to "P", "R", "N" or "D" position to check voltage between the TCM connector terminals and ground.

Shift position	Connector		F104		
	Terminal				
	27 - Ground	34 - Ground	35 - Ground	36 - Ground	32 - Ground
P	Battery voltage	10.0V - Battery voltage	8.0V - Battery voltage	10.0V - Battery voltage	8.0V - Battery voltage
R	0V	10.0V - Battery voltage	8.0V - Battery voltage	0V	8.0V - Battery voltage
N	0V	0V	8.0V - Battery voltage	10.0V - Battery voltage	8.0V - Battery voltage
D	0V	0V	0V	0V	0V

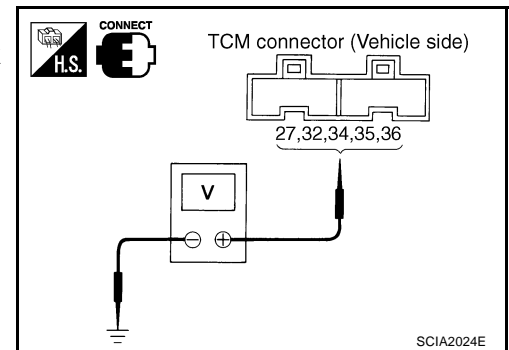

OK or NG

- OK >> GO TO 5.
 NG >> GO TO 2.

DTC P0705 PARK/NEUTRAL POSITION SWITCH

2. CHECK HARNESS BETWEEN TCM AND PNP SWITCH

1. Turn ignition switch OFF.
2. Disconnect TCM connector.
3. Check continuity between TCM connector terminal and ground.

Connector	Terminal	Condition	Continuity
F104	27 - ground	Select lever in "P" position.	No
		Select lever in "R", "N" and "D" positions.	Yes
	32 - ground	Select lever in "P", "R" and "N" positions.	No
		Select lever in "D" position.	Yes
	34 - ground	Select lever in "P", "R" positions.	No
		Select lever in "N", "D" positions.	Yes
35 - ground	Select lever in "P", "R" and "N" positions.	No	
	Select lever in "D" position.	Yes	
36 - ground	Select lever in "P", "N" positions.	No	
	Select lever in "R", "D" positions.	Yes	

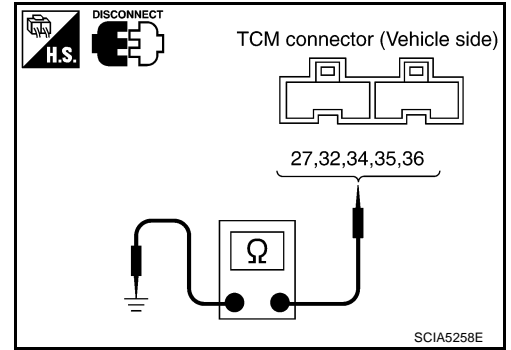

4. If OK, check harness for short-circuit to ground or power supply.

OK or NG

- OK >> GO TO 5.
 NG >> GO TO 3.

3. CHECK HARNESS BETWEEN TCM AND PNP SWITCH

1. Turn ignition switch OFF.
2. Disconnect TCM connector and CVT unit harness connector.
3. Check continuity between TCM connector terminal and CVT unit harness connector terminal.

Item	Connector	Terminal	Continuity
TCM	F104	27	Yes
CVT unit harness connector	F6	4	
TCM	F104	34	Yes
CVT unit harness connector	F6	5	
TCM	F104	35	Yes
CVT unit harness connector	F6	14	
TCM	F104	32	Yes
CVT unit harness connector	F6	18	
TCM	F104	36	Yes
CVT unit harness connector	F6	15	

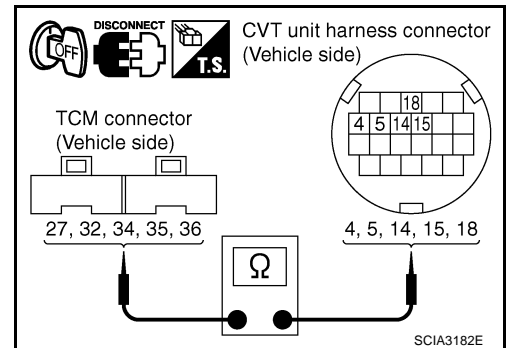

4. If OK, check harness for short to ground and short to power.

5. Reinstall any part removed.

OK or NG

- OK >> GO TO 4.
 NG >> Repair or replace damaged parts.

DTC P0705 PARK/NEUTRAL POSITION SWITCH

4. DETECT MALFUNCTIONING ITEM

Check the following.

- PNP switch. Refer to [CVT-80, "Component Inspection"](#) .

OK or NG

- OK >> GO TO 5.
- NG >> Repair or replace damaged parts.

5. CHECK DTC

Perform "DTC Confirmation Procedure". Refer to [CVT-74, "DTC Confirmation Procedure"](#) .

OK or NG

- OK >> **INSPECTION END**
- NG >> GO TO 6.

6. CHECK TCM

1. Check TCM input/output signal. Refer to [CVT-50, "TCM Input/Output Signal Reference Values"](#) .
2. If NG, re-check TCM pin terminals for damage or loose connection with harness connector.

OK or NG

- OK >> **INSPECTION END**
- NG >> 1. Repair or replace damaged parts.
2. Replace the transaxle assembly. Refer to [CVT-226, "Removal and Installation"](#) .

Component Inspection PNP SWITCH

ECS00F74

1. Change selector lever to various positions to check the continuity between terminals on the PNP switch and ground.

PNP SW	Shift position	Connector	Terminal	Continuity
SW 1	"R", "N" and "D"	F6	4 - Ground	Yes
	"P"			No
SW 2	"N", "D"		5 - Ground	Yes
	"P", "R"			No
SW 3	"D"		14 - Ground	Yes
	"P", "R" and "N"			No
SW 4	"R", "D"		15 - Ground	Yes
	"P", "N"			No
SW 3 monitor	"D"		18 - Ground	Yes
	"P", "R" and "N"			No

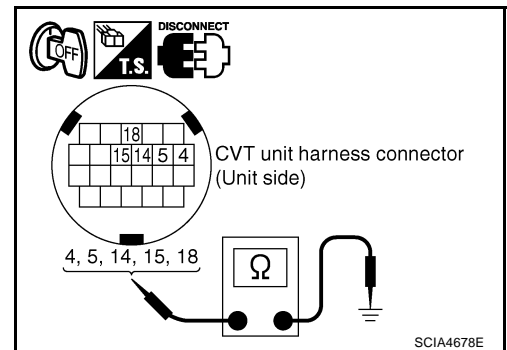

2. If NG, check continuity with control cable disconnected. (Refer to step 1 above.)
3. If OK, with the control cable disconnected, adjust the control linkage. Refer to [CVT-204, "Adjustment of CVT Position"](#) .
4. If NG, even when the control cable is disconnected, replace the transaxle assembly. Refer to [CVT-226, "Removal and Installation"](#) .

DTC P0710 CVT FLUID TEMPERATURE SENSOR CIRCUIT

DTC P0710 CVT FLUID TEMPERATURE SENSOR CIRCUIT

PDF:31020

Description

ECS00F75

The CVT fluid temperature sensor detects the CVT fluid temperature and sends a signal to the TCM.

CONSULT-II Reference Value

ECS00F76

Remarks: Specification data are reference values.

Item name	Condition	Display value (Approx.)
ATF TEMP SEN	Cold [20°C (68°F)]	1.8 - 2.0V
	Hot [80°C (176°F)]	0.6 - 1.0V

On Board Diagnosis Logic

ECS00F77

- This is an OBD-II self-diagnostic item.
- Diagnostic trouble code "P0710 ATF TEMP SEN/CIRC" with CONSULT-II is detected when TCM receives an excessively low or high voltage from the sensor.

Possible Cause

ECS00F78

- Harness or connectors
(Sensor circuit is open or shorted.)
- CVT fluid temperature sensor

DTC Confirmation Procedure

ECS00F79

CAUTION:

Always drive vehicle at a safe speed.

NOTE:

If "DTC Confirmation Procedure" has been previously performed, always turn ignition switch OFF and wait at least 10 seconds before performing the next test.

After the repair, touch "ERASE" on "SELF-DIAG RESULTS" and then perform the following procedure to confirm the malfunction is eliminated.

WITH CONSULT-II

1. Turn ignition switch ON. (Do not start engine.)
2. Select "DATA MONITOR" mode for "ENGINE" with CONSULT-II.
3. Start engine and maintain the following conditions for at least 10 minutes (Total).
VHCL SPEED SE: 10 km/h (6 MPH) or more
ENG SPEED: 450 rpm more than
ACC PEDAL OPEN: More than 1/8
Selector lever: "D" position
4. If DTC is detected, go to [CVT-83, "Diagnostic Procedure"](#).

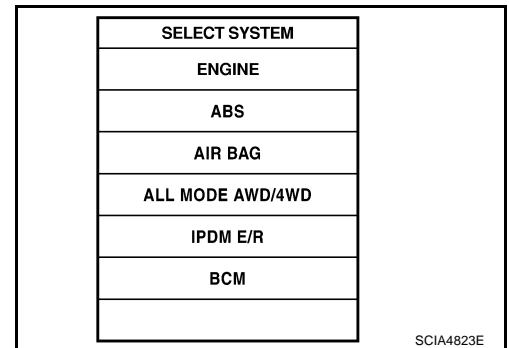

WITH GST

Follow the procedure "WITH CONSULT-II".

DTC P0710 CVT FLUID TEMPERATURE SENSOR CIRCUIT

Wiring Diagram — CVT — FTS

ECS00F7A

CVT-FTS-01

—— : DETECTABLE LINE FOR DTC
—— : NON-DETECTABLE LINE FOR DTC

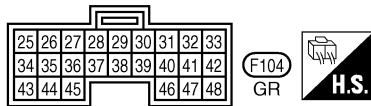
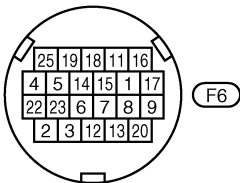
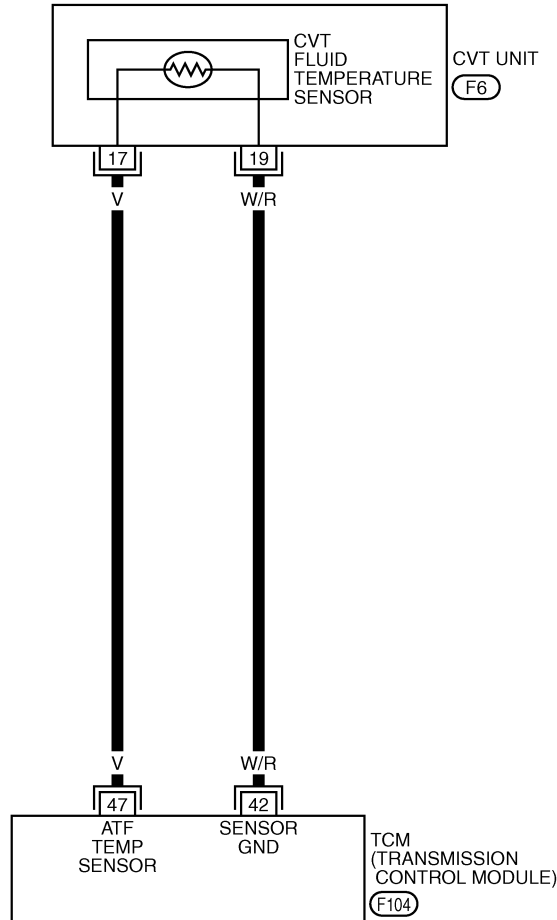

TCWA0247E

DTC P0710 CVT FLUID TEMPERATURE SENSOR CIRCUIT

TCM terminal data are reference values, measured between each terminal and ground.

Terminal	Wire color	Item	Condition	Data (Approx.)
42	W/R	Sensor ground	Always	0V
47	V	CVT fluid temperature sensor	When CVT fluid temperature is 20°C (68°F).	2.0V
			When CVT fluid temperature is 80°C (176°F).	1.0V

Diagnostic Procedure

ECS00F7B

CVT

1. CHECK CVT FLUID TEMPERATURE SENSOR SIGNAL

With CONSULT-II

- Start engine.
- Select "ECU INPUT SIGNALS" in "DATA MONITOR" mode for "TRANSMISSION" with CONSULT-II.
- Read out the value of "ATF TEMP SEN".

Item name	Condition	Display value (Approx.)
ATF TEMP SEN	Cold [20°C (68°F)]	1.8 - 2.0V
	Hot [80°C (176°F)]	0.6 - 1.0V

DATA MONITOR	
MONITOR	NO DTC
SEC HYDR SEN	0.47 v
PRI HYDR SEN	0.47 v
ATF TEMP SEN	1.92 v
VIGN SEN	10.7 v
ACC PEDAL OPEN	0.0 / 8

△	▽
RECORD	
MODE	BACK
LIGHT	COPY

SCIA2277E

Without CONSULT-II

- Start engine.
- Check voltage between TCM connector terminals.

Name	Connector	Terminal	Temperature °C (°F)	Voltage (Approx.)
CVT fluid temperature sensor	F104	47 - 42	20 (68)	2.0V
			80 (176)	1.0V

- Turn ignition switch OFF.
- Disconnect TCM connector.
- Check if there is continuity between connector terminal and ground.

OK or NG

- OK >> GO TO 5.
 NG >> GO TO 2.

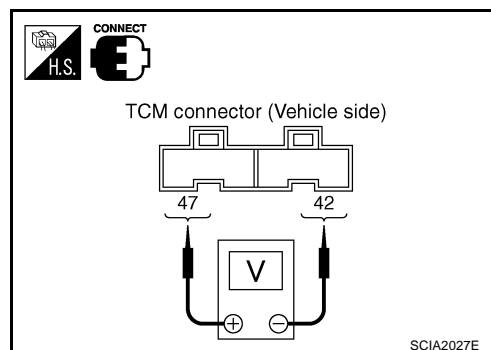

2. CHECK CVT FLUID TEMPERATURE SENSOR CIRCUIT

- Turn ignition switch OFF.
- Disconnect the TCM connector.
- Check resistance between TCM connector terminals.

Name	Connector	Terminal	Temperature °C (°F)	Resistance (Approx.)
CVT fluid temperature sensor	F104	47 - 42	20 (68)	6.5 kΩ
			80 (176)	0.9 kΩ

OK or NG

- OK >> GO TO 5.
 NG >> GO TO 3.

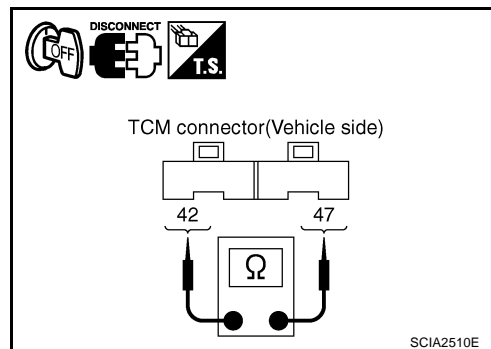

DTC P0710 CVT FLUID TEMPERATURE SENSOR CIRCUIT

3. CHECK CVT FLUID TEMPERATURE SENSOR

1. Turn ignition switch OFF.
2. Disconnect CVT unit harness connector.
3. Check resistance between CVT unit harness connector terminals.

Name	Connector	Terminal	Temperature °C (°F)	Resistance (Approx.)
CVT fluid temperature sensor	F6	17 - 19	20 (68)	6.5 kΩ
			80 (176)	0.9 kΩ

4. Reinstall any part removed.

OK or NG

- OK >> GO TO 4.
 NG >> Replace the transaxle assembly. Refer to [CVT-226, "Removal and Installation"](#).

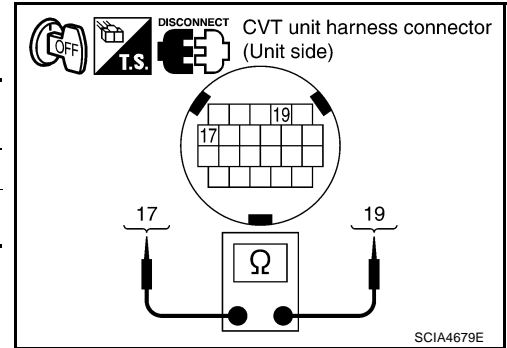

4. CHECK HARNESS BETWEEN TCM AND CVT FLUID TEMPERATURE SENSOR

1. Turn ignition switch OFF.
2. Disconnect the TCM connector and CVT unit harness connector.
3. Check continuity between TCM connector terminal and CVT unit harness connector terminal.

Item	Connector	Terminal	Continuity
TCM	F104	42	Yes
CVT unit harness connector	F6	19	
TCM	F104	47	Yes
CVT unit harness connector	F6	17	

4. If OK, check harness for short to ground and short to power.
5. Reinstall any part removed.

OK or NG

- OK >> GO TO 5.
 NG >> Repair or replace damaged parts.

5. CHECK DTC

Perform "DTC Confirmation Procedure". Refer to [CVT-81, "DTC Confirmation Procedure"](#).

OK or NG

- OK >> **INSPECTION END**
 NG >> GO TO 6.

6. CHECK TCM

1. Check TCM input/output signal. Refer to [CVT-50, "TCM Input/Output Signal Reference Values"](#).
2. If NG, re-check TCM pin terminals for damage or loose connection with harness connector.

OK or NG

- OK >> **INSPECTION END**
 NG >> Repair or replace damaged parts.

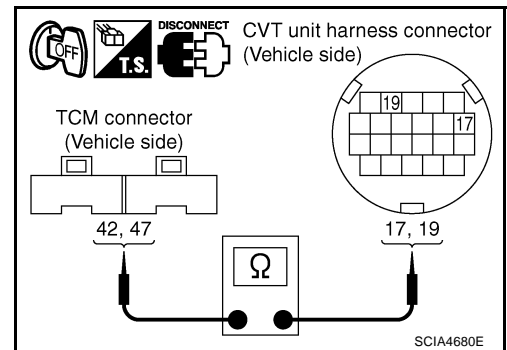

DTC P0710 CVT FLUID TEMPERATURE SENSOR CIRCUIT

ECS00F7C

Component Inspection CVT FLUID TEMPERATURE SENSOR

1. Turn ignition switch OFF.
2. Disconnect CVT unit harness connector.
3. Check resistance between CVT unit harness connector terminals.

Name	Connector	Terminal	Temperature °C (°F)	Resistance (Approx.)
CVT fluid temperature sensor	F6	17 - 19	20 (68)	6.5 kΩ
			80 (176)	0.9 kΩ

4. If NG, replace the transaxle assembly. Refer to [CVT-226](#), "[Removal and Installation](#)".

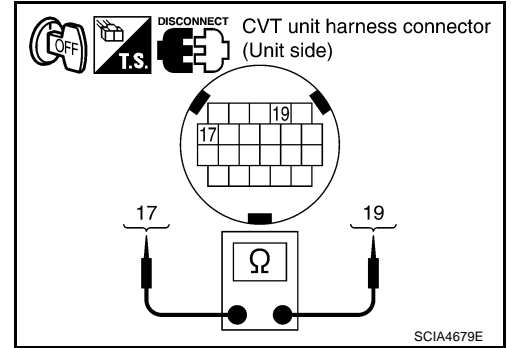

A
B
CVT
D
E
F
G
H
I
J
K
L
M

DTC P0715 INPUT SPEED SENSOR CIRCUIT (PRI SPEED SENSOR)

DTC P0715 INPUT SPEED SENSOR CIRCUIT (PRI SPEED SENSOR)

PFP:31935

Description

ECS00F7D

The input speed sensor (primary speed sensor) detects the primary pulley revolution speed and sends a signal to the TCM.

CONSULT-II Reference Value

ECS00F7E

Remarks: Specification data are reference values.

Item name	Condition	Display value
ENG SPEED SIG	Engine running	Closely matches the tachometer reading.
PRI SPEED SEN	During driving (lock-up ON)	Approximately matches the engine speed.

On Board Diagnosis Logic

ECS00F7F

- This is an OBD-II self-diagnostic item.
- Diagnostic trouble code "P0715 INPUT SPD SEN/CIRC" with CONSULT-II is detected when TCM does not receive the proper signal from the sensor.

Possible Cause

ECS00F7G

- Harness or connectors
(Sensor circuit is open or shorted.)
- Input speed sensor (Primary speed sensor)

DTC Confirmation Procedure

ECS00F7H

CAUTION:

- Always drive vehicle at a safe speed.
- Be careful not to rev engine into the red zone on the tachometer.

NOTE:

If "DTC Confirmation Procedure" has been previously performed, always turn ignition switch OFF and wait at least 5 seconds before performing the next test.

After the repair, touch "ERASE" on "SELF-DIAG RESULTS" and then perform the following procedure to confirm the malfunction is eliminated.

WITH CONSULT-II

1. Turn ignition switch ON and select "DATA MONITOR" mode for "ENGINE" with CONSULT-II.
2. Start engine and maintain the following conditions for at least 5 consecutive seconds.
VHCL SPEED SE: 10 km/h (6 MPH) or more
ACC PEDAL OPEN: More than 1/8
Selector lever: "D" position
ENG SPEED: 450 rpm or more
Driving location: Driving the vehicle uphill (increased engine load) will help maintain the driving conditions required for this test.
3. If DTC is detected, go to [CVT-88, "Diagnostic Procedure"](#).

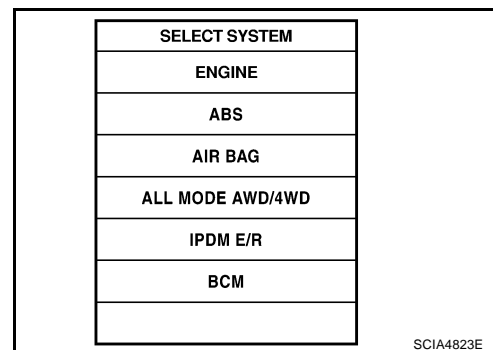

WITH GST

Follow the procedure "WITH CONSULT-II".

DTC P0715 INPUT SPEED SENSOR CIRCUIT (PRI SPEED SENSOR)

Wiring Diagram — CVT — PRSCVT

ECS00F71

CVT-PRSCVT-01

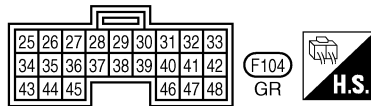
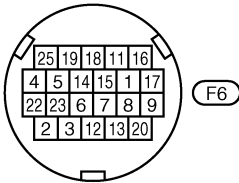
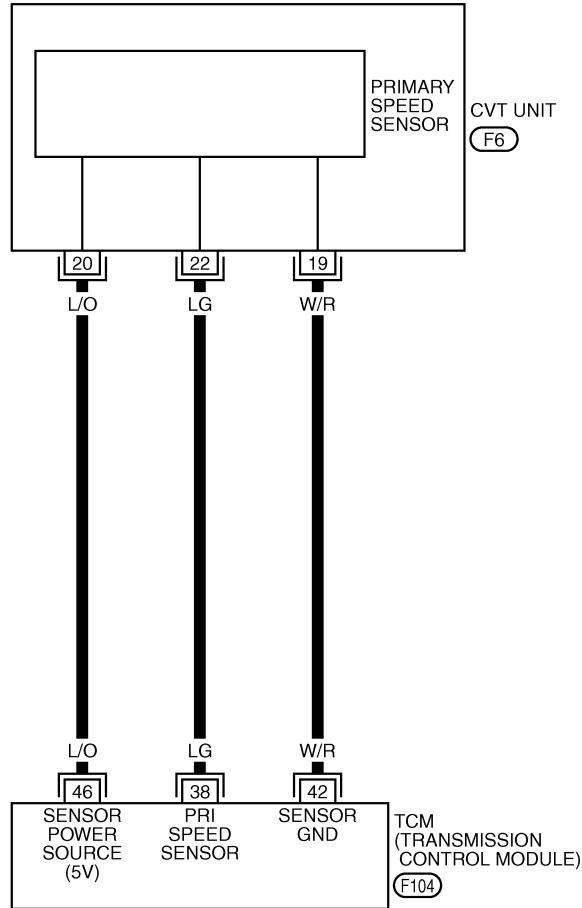

— : DETECTABLE LINE FOR DTC
— : NON-DETECTABLE LINE FOR DTC



TCWA0254E

DTC P0715 INPUT SPEED SENSOR CIRCUIT (PRI SPEED SENSOR)

TCM terminal data are reference values, measured between each terminal and ground.

Terminal	Wire color	Item	Condition	Data (Approx.)
38	LG	Input speed sensor (Primary speed sensor)	 When driving ["D" position, 20 km/h (12 MPH)].	600 Hz
42	W/R	Sensor ground	Always	0V
46	L/O	Sensor power		—
				—

Diagnostic Procedure

ECS00F7J

1. CHECK INPUT SIGNALS

With CONSULT-II

- Start engine.
- Select "ECU INPUT SIGNALS" in "DATA MONITOR" mode for "TRANSMISSION" with CONSULT-II.
- Start vehicle and read out the value of "PRI SPEED SEN".

Item name	Condition	Display value
PRI SPEED SEN	During driving (lock-up ON)	Approximately matches the engine speed.

DATA MONITOR	
MONITOR	NO DTC
PRI SPEED SEN	32 rpm
ENG SPEED SIG	0 rpm
SEC HYDR SEN	0.47 V
PRI HYDR SEN	0.47 V
ATF TEMP SEN	1.92 V

▼			
RECORD			
MODE	BACK	LIGHT	COPY

SCIA2278E

OK or NG

- OK >> GO TO 6.
 NG >> GO TO 2.

2. CHECK INPUT SPEED SENSOR (PRIMARY SPEED SENSOR)

- Start engine.
- Check voltage between TCM connector terminals.

Item	Connector	Terminal	Data (Approx.)
TCM	F104	46 - 42	4.5 - 5.5V

- Check the pulse with CONSULT-II or oscilloscope, when vehicle cruises.

Name	Condition
Input speed sensor (Primary speed sensor)	When running at 20 km/h (12 MPH) in "D" position with the closed throttle position signal "OFF", use the CONSULT-II pulse frequency measuring function. CAUTION: Connect the data link connector to the vehicle-side diagnosis connector.

Item	Connector	Terminal	Name	Data (Approx.)
TCM	F104	38	Input speed sensor (Primary speed sensor)	600 Hz

OK or NG

- OK >> GO TO 6.
 NG - 1 >> Battery voltage is not supplied: GO TO 3.
 NG - 2 >> Battery voltage is supplied, but there is a malfunction in the frequency: GO TO 4.

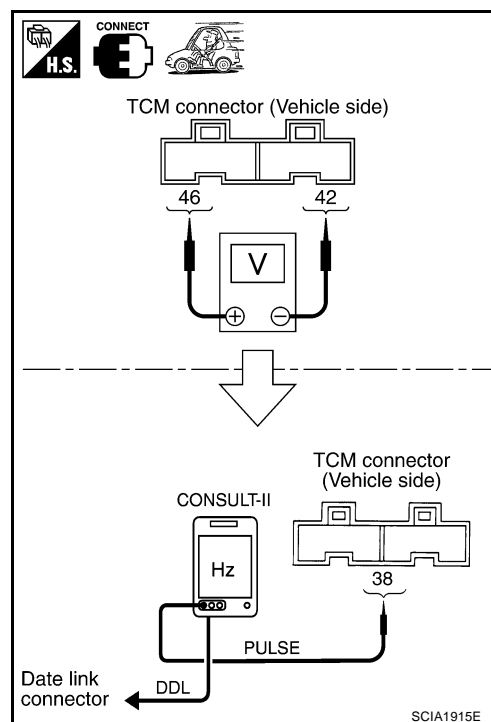

DTC P0715 INPUT SPEED SENSOR CIRCUIT (PRI SPEED SENSOR)

3. CHECK HARNESS BETWEEN TCM AND CVT UNIT HARNESS CONNECTOR (SENSOR POWER AND SENSOR GROUND)

1. Turn ignition switch OFF.
2. Disconnect TCM connector and CVT unit harness connector.
3. Check continuity between TCM connector terminal and CVT unit harness connector terminal.

Item	Connector	Terminal	Continuity
TCM	F104	42	Yes
CVT unit harness connector	F6	19	
TCM	F104	46	Yes
CVT unit harness connector	F6	20	

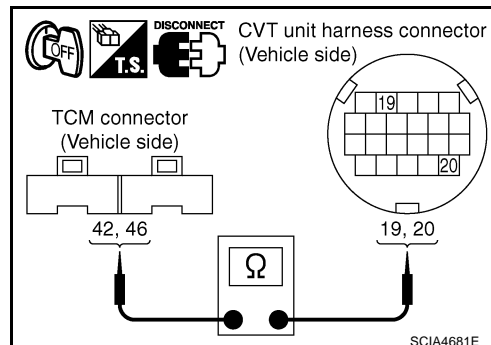

4. If OK, check harness for short to ground and short to power.
5. Reinstall any part removed.

OK or NG

OK >> GO TO 6.

NG >> Repair open circuit or short to ground or short to power in harness or connectors.

4. CHECK HARNESS BETWEEN TCM AND CVT UNIT HARNESS CONNECTOR [INPUT SPEED SENSOR (PRIMARY SPEED SENSOR)]

1. Turn ignition switch OFF.
2. Disconnect TCM connector and CVT unit harness connector.
3. Check continuity between TCM connector terminal and CVT unit harness connector terminal.

Item	Connector	Terminal	Continuity
TCM	F104	38	Yes
CVT unit harness connector	F6	22	

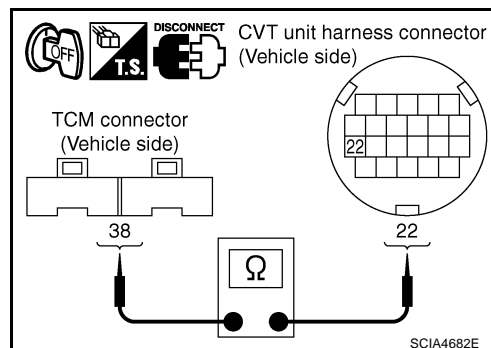

4. If OK, check harness for short to ground and short to power.
5. Reinstall any part removed.

OK or NG

OK >> GO TO 5.

NG >> Repair open circuit or short to ground or short to power in harness or connectors.

5. CHECK THE TCM SHORT

Replace same type TCM, perform self-diagnosis check. Erase self-diagnostic results and then drive the vehicle [10 km/h (6 MPH) or more], perform self-diagnosis check. Refer to [CVT-86, "DTC Confirmation Procedure"](#)

Is the "P0715 INPUT SPD SEN/CIRC" detected again?

YES >> Replace the transaxle assembly. Refer to [CVT-226, "Removal and Installation"](#).

NO >> Replace TCM. Refer to [CVT-8, "Precautions for TCM and CVT Assembly Replacement"](#).

6. CHECK DTC

Perform "DTC Confirmation Procedure". Refer to [CVT-86, "DTC Confirmation Procedure"](#).

OK or NG

OK >> **INSPECTION END**

NG >> GO TO 7.

DTC P0715 INPUT SPEED SENSOR CIRCUIT (PRI SPEED SENSOR)

7. CHECK TCM

1. Check TCM input/output signal. Refer to [CVT-50, "TCM Input/Output Signal Reference Values"](#) .
2. If NG, re-check TCM pin terminals for damage or loose connection with harness connector.

OK or NG

- OK >> **INSPECTION END**
NG >> Repair or replace damaged parts.

DTC P0720 VEHICLE SPEED SENSOR CVT (SECONDARY SPEED SENSOR)

DTC P0720 VEHICLE SPEED SENSOR CVT (SECONDARY SPEED SENSOR)

PPF:31935

Description

ECS00F7K

The vehicle speed sensor CVT [output speed sensor (secondary speed sensor)] detects the revolution of the CVT output shaft and emits a pulse signal. The pulse signal is sent to the TCM, which converts it into vehicle speed.

CONSULT-II Reference Value

ECS00F7L

Remarks: Specification data are reference values.

Item name	Condition	Display value
VSP SENSOR	During driving	Approximately matches the speedometer reading.

On Board Diagnosis Logic

ECS00F7M

- This is an OBD-II self-diagnostic item.
- Diagnostic trouble code "P0720 VEH SPD SEN/CIR AT" with CONSULT-II is detected TCM does not receive the proper signal from the sensor.

Possible Cause

ECS00F7N

- Harness or connectors
(Sensor circuit is open or shorted.)
- Output speed sensor (Secondary speed sensor)

DTC Confirmation Procedure

ECS00F7O

CAUTION:

- Always drive vehicle at a safe speed.
- Be careful not to rev engine into the red zone on the tachometer.

NOTE:

If "DTC Confirmation Procedure" has been previously performed, always turn ignition switch OFF and wait at least 5 seconds before performing the next test.

After the repair, touch "ERASE" on "SELF-DIAG RESULTS" and then perform the following procedure to confirm the malfunction is eliminated.

WITH CONSULT-II

1. Turn ignition switch ON and select "DATA MONITOR" mode for "ENGINE" with CONSULT-II.
2. Start engine and maintain the following conditions for at least 12 consecutive seconds.

ACC PEDAL OPEN: More than 1/8

Selector lever: "D" position

Driving location: Driving the vehicle uphill (increased engine load) will help maintain the driving conditions required for this test.

3. If DTC is detected, go to [CVT-93, "Diagnostic Procedure"](#).

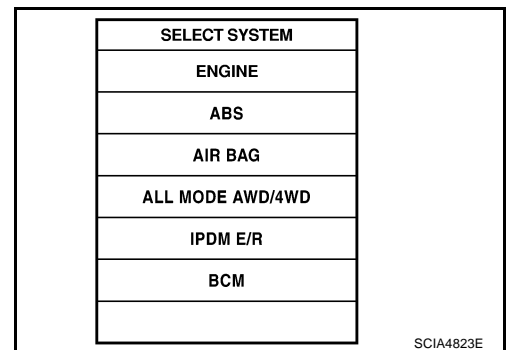

WITH GST







Follow the procedure "WITH CONSULT-II".

DTC P0720 VEHICLE SPEED SENSOR CVT (SECONDARY SPEED SENSOR)

Wiring Diagram — CVT — SESCVT

EC500F7P

CVT-SESCVT-01

-  : DETECTABLE LINE FOR DTC
-  : NON-DETECTABLE LINE FOR DTC
-  : LHD MODELS
-  : RHD MODELS
- *1 7: 
- 8: 

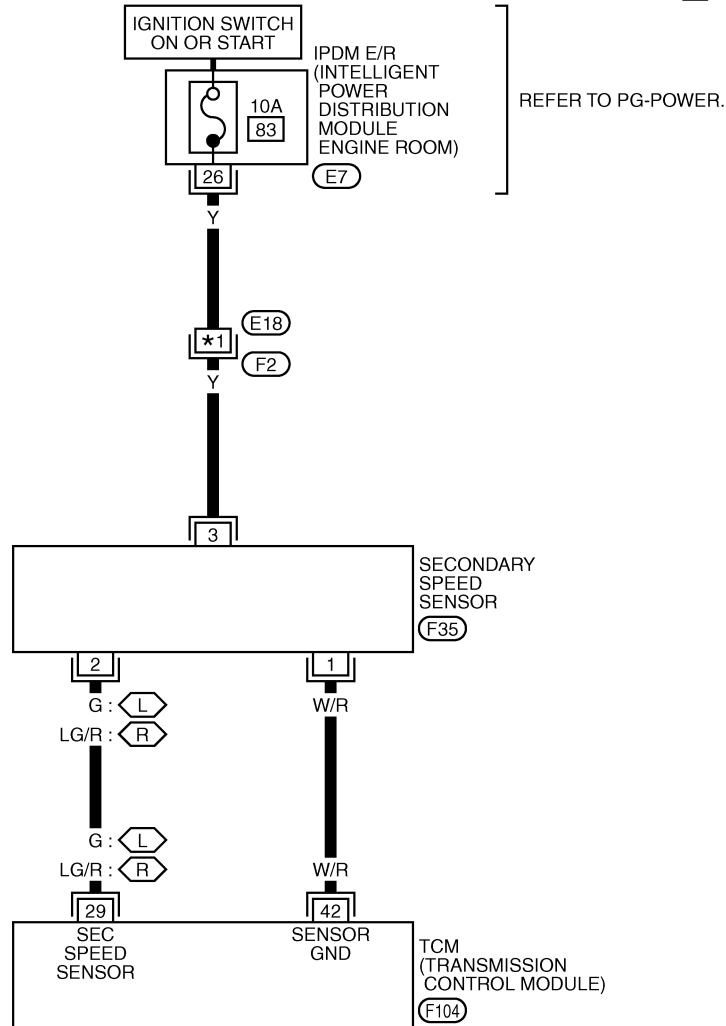

23	22	21	20	19	18	17		
32	31	30	29	28	27	26	25	24

(E7) GR



1	2	3	4	5
6	7	8	9	

(F2) GR

1	2	3
---	---	---

(F35) B

25	26	27	28	29	30	31	32	33
34	35	36	37	38	39	40	41	42
43	44	45		46	47	48		

(F104) GR



TCWB0139E

DTC P0720 VEHICLE SPEED SENSOR CVT (SECONDARY SPEED SENSOR)

TCM terminal data are reference values, measured between each terminal and ground.

Terminal	Wire color	Item	Condition	Data (Approx.)
29	G*1 LG/R*2	Output speed sensor (Secondary speed sensor)	 When driving ["D" position, 20 km/h (12 MPH)].	300 Hz
42	W/R	Sensor ground	Always	0V

*1: LHD models.

*2: RHD models.

Diagnostic Procedure

ECS00F70

1. CHECK INPUT SIGNAL

With CONSULT-II

- Start engine.
- Select "ECU INPUT SIGNALS" in "DATA MONITOR" mode for "TRANSMISSION" with CONSULT-II.
- Start vehicle and read out the value of "VSP SENSOR".

Item name	Condition	Display value
VSP SENSOR	During driving	Approximately matches the speedometer reading.

DATA MONITOR	
MONITOR	NO DTC
VSP SENSOR	1 km / h
ESTM VSP SIG	0 km / h
PRI SPEED SEN	32 rpm
ENG SPEED SIG	0 rpm
SEC HYDR SEN	0.47 V
▼	
RECORD	
MODE	BACK
LIGHT	COPY

SCIA2279E

OK or NG

- OK >> GO TO 8.
NG >> GO TO 2.

2. CHECK SECONDARY SPEED SENSOR

With CONSULT-II

- Start engine.
- Check power supply to output speed sensor (secondary speed sensor) by voltage between TCM connector terminals 10, 19 and 42. Refer to [CVT-36, "Circuit Diagram"](#).

Item	Connector	Terminal	Data (Approx.)
TCM	F103, F104	10 - 42	Battery voltage
		19 - 42	

- If OK, check the pulse when vehicle cruises.

Name	Condition
Output speed sensor (Secondary speed sensor)	When running at 20 km/h (12 MPH) in "D" position, use the CONSULT-II pulse frequency measuring function. CAUTION: Connect the data link connector to the vehicle-side diagnosis connector.

Item	Connector	Terminal	Name	Data (Approx.)
TCM	F104	29	Output speed sensor (Secondary speed sensor)	300 Hz

OK or NG

- OK >> GO TO 8.
NG >> GO TO 3.

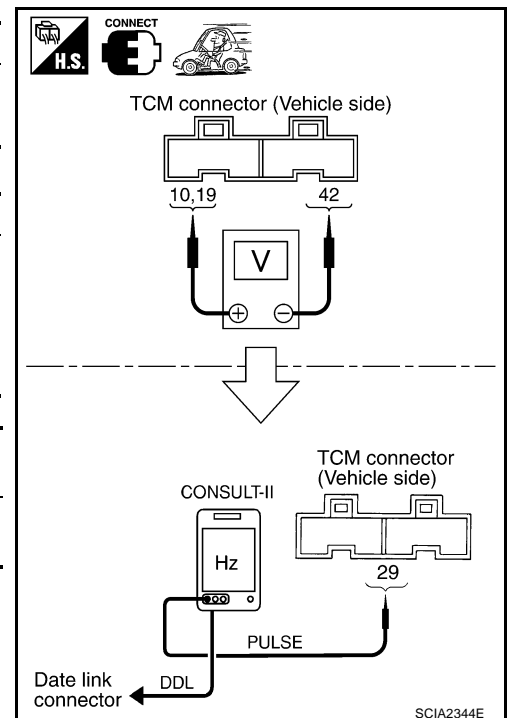

DTC P0720 VEHICLE SPEED SENSOR CVT (SECONDARY SPEED SENSOR)

3. CHECK POWER AND SENSOR GROUND

1. Turn ignition switch OFF.
2. Disconnect the output speed sensor (secondary speed sensor) harness connector.
3. Turn ignition switch ON.
4. Check voltage between output speed sensor (secondary speed sensor) harness connector terminals.

Item	Connector	Terminal	Data (Approx.)
Output speed sensor (Secondary speed sensor)	F35	1 - 3	Battery voltage

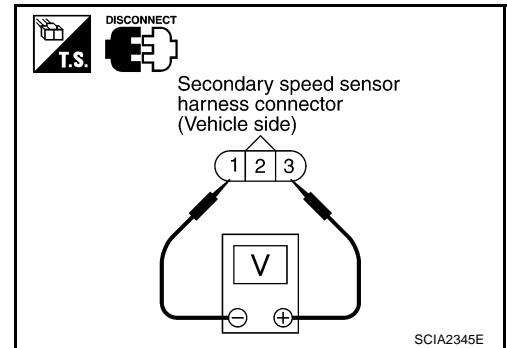

5. Check voltage between output speed sensor (secondary speed sensor) harness connector terminal and ground.

Item	Connector	Terminal	Data (Approx.)
Output speed sensor (Secondary speed sensor)	F35	3 - ground	Battery voltage

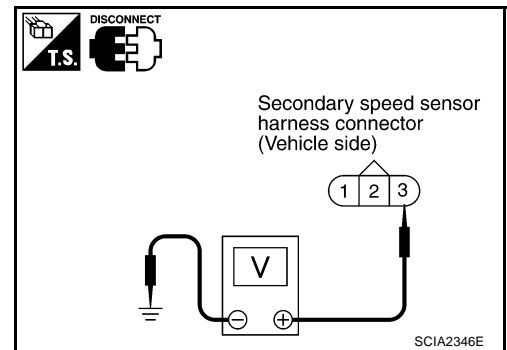

6. If OK, check harness for short to ground and short to power.
7. Reinstall any part removed.

OK or NG

OK >> GO TO 4.

NG - 1 >> Battery voltage is not supplied between terminals 1 and 3, terminals 1 and ground.: GO TO 6.

NG - 2 >> Battery voltage is not supplied between terminals 1 and 3 only.: GO TO 7.

4. CHECK HARNESS BETWEEN TCM AND OUTPUT SPEED SENSOR (SECONDARY SPEED SENSOR)

1. Turn ignition switch OFF.
2. Disconnect TCM connector and output speed sensor (secondary speed sensor) harness connector.
3. Check continuity between TCM connector terminal and output speed sensor (secondary speed sensor) harness connector terminal.

Item	Connector	Terminal	Continuity
TCM	F104	29	Yes
Output speed sensor (Secondary speed sensor)	F35	2	

4. If OK, check harness for short to ground and short to power.
5. Reinstall any part removed.

OK or NG

OK >> GO TO 5.

NG >> Repair open circuit or short to ground or short to power in harness or connectors.

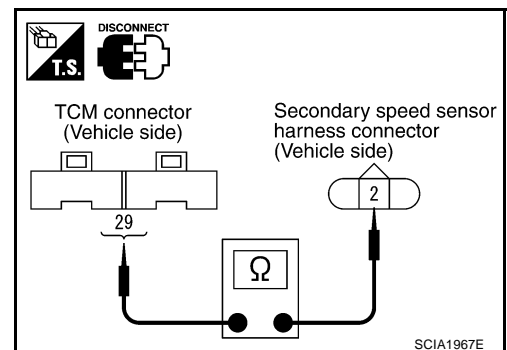

DTC P0720 VEHICLE SPEED SENSOR CVT (SECONDARY SPEED SENSOR)

5. CHECK THE TCM SHORT

Replace same type TCM, perform self-diagnosis check. Erase self-diagnostic results and then drive the vehicle [more than 40 km/h (25 MPH)], perform self-diagnosis check. Refer to [CVT-91, "DTC Confirmation Procedure"](#).

Is "P0720 VEH SPD SEN/CIR AT" detected again?

- YES >> Replace the transaxle assembly. Refer to [CVT-226, "Removal and Installation"](#).
- NO >> Replace TCM. Refer to [CVT-8, "Precautions for TCM and CVT Assembly Replacement"](#).

6. CHECK HARNESS BETWEEN TCM AND OUTPUT SPEED SENSOR (SECONDARY SPEED SENSOR) (POWER)

1. Turn ignition switch OFF.
2. Disconnect TCM connector and output speed sensor (secondary speed sensor) harness connector.
3. Check continuity between TCM connector terminal and output speed sensor (secondary speed sensor) harness connector terminal. Refer to [CVT-36, "Circuit Diagram"](#).

Item	Connector	Terminal	Continuity
TCM	F103	10	Yes
Output speed sensor (Secondary speed sensor)	F35	3	
TCM	F103	19	Yes
Output speed sensor (Secondary speed sensor)	F35	3	

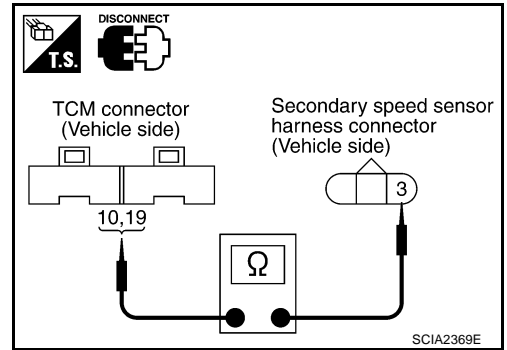

4. If OK, check harness for short to ground and short to power.
5. Reinstall any part removed.

OK or NG

- OK >> 10A fuse (No. 83, located in the IPDM E/R) or ignition switch are malfunctioning.
- NG >> Repair open circuit or short to ground or short to power in harness or connectors.

7. CHECK HARNESS BETWEEN TCM AND OUTPUT SPEED SENSOR (SECONDARY SPEED SENSOR) (SENSOR GROUND)

1. Turn ignition switch OFF.
2. Disconnect TCM connector and output speed sensor (secondary speed sensor) harness connector.
3. Check continuity between TCM connector terminal and output speed sensor (secondary speed sensor) harness connector terminal. Refer to [CVT-36, "Circuit Diagram"](#).

Item	Connector	Terminal	Continuity
TCM	F104	42	Yes
Output speed sensor (Secondary speed sensor)	F35	1	

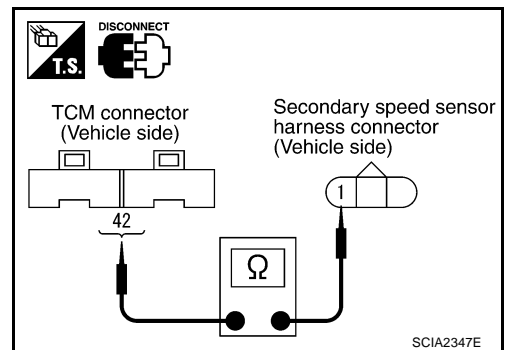

4. If OK, check harness for short to ground and short to power.
5. Reinstall any part removed.

OK or NG

- OK >> GO TO 8.
- NG >> Repair open circuit or short to ground or short to power in harness or connectors.

8. CHECK DTC

Perform "DTC Confirmation Procedure". Refer to [CVT-91, "DTC Confirmation Procedure"](#).

OK or NG

- OK >> **INSPECTION END**
- NG >> GO TO 9.

DTC P0720 VEHICLE SPEED SENSOR CVT (SECONDARY SPEED SENSOR)

9. CHECK TCM

1. Check TCM input/output signal. Refer to [CVT-50, "TCM Input/Output Signal Reference Values"](#) .
2. If NG, re-check TCM pin terminals for damage or loose connection with harness connector.

OK or NG

- OK >> **INSPECTION END**
NG >> Repair or replace damaged parts.

DTC P0725 ENGINE SPEED SIGNAL

DTC P0725 ENGINE SPEED SIGNAL

PFP:24825

Description

ECS00F7R

The engine speed signal is sent from the ECM to the TCM.

CONSULT-II Reference Value

ECS00F7S

Remarks: Specification data are reference values.

Item name	Condition	Display value
ENG SPEED SIG	Engine running	Closely matches the tachometer reading.
ACC PEDAL OPEN	Released accelerator pedal - Fully depressed accelerator pedal	0.0/8 - 8.0/8

On Board Diagnosis Logic

ECS00F7T

- This is not an OBD-II self-diagnostic item.
- Diagnostic trouble code "P0725 ENGINE SPEED SIG" with CONSULT-II is detected when TCM does not receive the engine speed signal (input by CAN communication) from ECM.

Possible Cause

ECS00F7U

Harness or connectors
(The ECM to the TCM circuit is open or shorted.)

DTC Confirmation Procedure

ECS00F7V

CAUTION:

Always drive vehicle at a safe speed.

NOTE:

If "DTC Confirmation Procedure" has been previously performed, always turn ignition switch OFF and wait at least 10 seconds before performing the next test.

After the repair, touch "ERASE" on "SELF-DIAG RESULTS" and then perform the following procedure to confirm the malfunction is eliminated.

WITH CONSULT-II

1. Turn ignition switch ON and select "DATA MONITOR" mode for "TRANSMISSION" with CONSULT-II.
2. Start engine and maintain the following conditions for at least 10 consecutive seconds.
PRI SPEED SEN: More than 1,000 rpm
3. If DTC is detected, go to [CVT-97, "Diagnostic Procedure"](#).

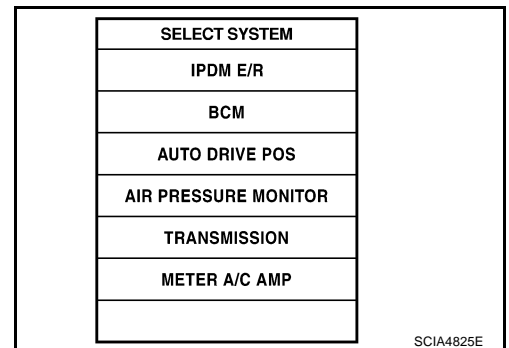

Diagnostic Procedure

ECS00F7W

1. CHECK DTC WITH ECM

With CONSULT-II

1. Turn ignition switch ON. (Do not start engine.)
2. Select "SELF-DIAG RESULTS" mode for "ENGINE" with CONSULT-II. Refer to [EC-101, "SELF-DIAG RESULTS MODE"](#).

OK or NG

OK >> GO TO 2.

NG >> Check the DTC detected item. Refer to [EC-101, "SELF-DIAG RESULTS MODE"](#).

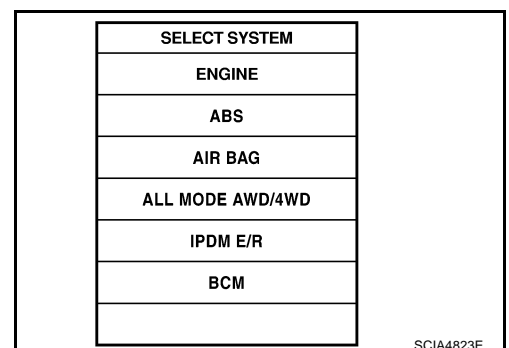

DTC P0725 ENGINE SPEED SIGNAL

2. CHECK DTC WITH TCM

With CONSULT-II

1. Turn ignition switch ON. (Do not start engine.)
2. Select "SELF-DIAG RESULTS" mode for "TRANSMISSION" with CONSULT-II. Refer to [CVT-58, "SELF-DIAGNOSTIC RESULT MODE"](#).

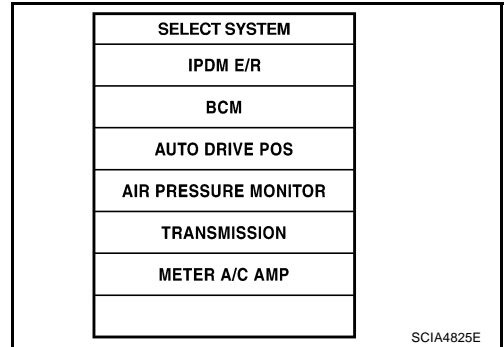

OK or NG

- OK >> GO TO 3.
 NG >> Check the DTC detected item. Refer to [CVT-58, "SELF-DIAGNOSTIC RESULT MODE"](#).
- If DTC of CAN communication line is detected, go to [CVT-65, "DTC U1000 CAN COMMUNICATION LINE"](#)

3. CHECK INPUT SIGNALS

With CONSULT-II

1. Start engine.
2. Select "ECU INPUT SIGNALS" in "DATA MONITOR" mode for "TRANSMISSION" with CONSULT-II.
3. While monitoring "ENG SPEED SIG", check for engine speed change corresponding to "ACC PEDAL OPEN".

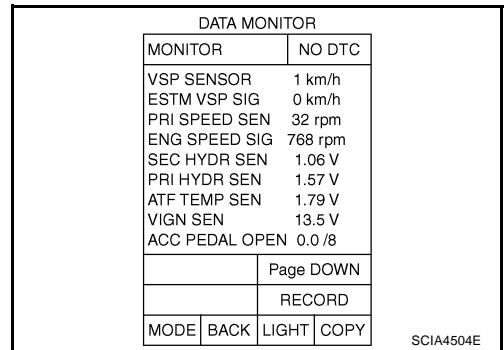

Item name	Condition	Display value
ENG SPEED SIG	Engine running	Closely matches the tachometer reading.
ACC PEDAL OPEN	Released accelerator pedal - Fully depressed accelerator pedal	0.0/8 - 8.0/8

OK or NG

- OK >> GO TO 4.
 NG >> Check ignition signal circuit.
- Refer to [EC-606, "IGNITION SIGNAL"](#).

4. CHECK DTC

Perform "DTC Confirmation Procedure". Refer to [CVT-97, "DTC Confirmation Procedure"](#).

OK or NG

- OK >> **INSPECTION END**
 NG >> GO TO 5.

5. CHECK TCM

1. Check TCM input/output signal. Refer to [CVT-50, "TCM Input/Output Signal Reference Values"](#).
2. If NG, re-check TCM pin terminals for damage or loose connection with harness connector.

OK or NG

- OK >> **INSPECTION END**
 NG >> Repair or replace damaged parts.

DTC P0730 BELT DAMAGE

DTC P0730 BELT DAMAGE

PFP:31935

Description

ECS00F7X

TCM selects the gear ratio using the engine load (throttle position), the primary pulley revolution speed, and the secondary pulley revolution speed as input signal. Then it changes the operating pressure of the primary pulley and the secondary pulley and changes the groove width of the pulley.

CONSULT-II Reference Value

ECS00F7Y

Remarks: Specification data are reference values.

Item name	Condition	Display value (Approx.)
GEAR RATIO	During driving	2.37 - 0.43

On Board Diagnosis Logic

ECS00F7Z

- This is not an OBD-II self-diagnostic item.
- TCM calculates the actual gear ratio with input speed sensor (primary speed sensor) and output speed sensor (secondary speed sensor).
- Diagnostic trouble code "P0730 BELT DAMG" with CONSULT-II is detected, when TCM receives an unexpected gear ratio signal.

Possible Cause

ECS00F80

Transaxle assembly

DTC Confirmation Procedure

ECS00F81

CAUTION:

- Always drive vehicle at a safe speed.
- Be careful not to rev engine into the red zone on the tachometer.

NOTE:

If "DTC Confirmation Procedure" has been previously performed, always turn ignition switch OFF and wait at least 5 seconds before performing the next test.

After the repair, perform the following procedure to confirm the malfunction is eliminated.

Ⓟ WITH CONSULT-II

1. Turn ignition switch ON and select "DATA MONITOR" mode for "TRANSMISSION" with CONSULT-II.
2. Make sure that output voltage of CVT fluid temperature sensor is within the range below.

FLUID TEMP SEN: 1.0 - 2.0V

If out of range, drive the vehicle to decrease the voltage (warm up the fluid) or stop engine to increase the voltage (cool down the fluid)

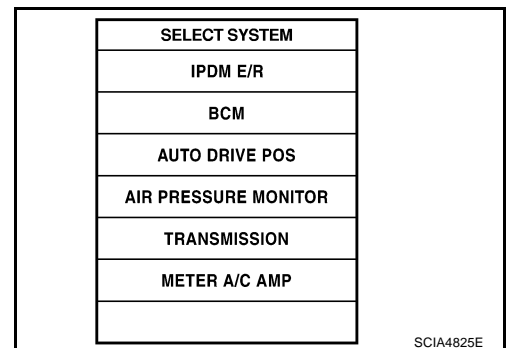

3. Select "DATA MONITOR" mode for "TRANSMISSION" with CONSULT-II.
4. Start engine and maintain the following conditions for at least 30 consecutive seconds.

TEST START FROM 0 km/h (0 MPH)

CONSTANT ACCELERATION: Keep 30 sec or more

VEHICLE SPEED: 10 km/h (6 MPH) or more

ACC PEDAL OPEN: More than 1/8

Selector lever: "D" position

ENG SPEED: 450 rpm or more

5. If DTC is detected, go to [CVT-100, "Diagnostic Procedure"](#).

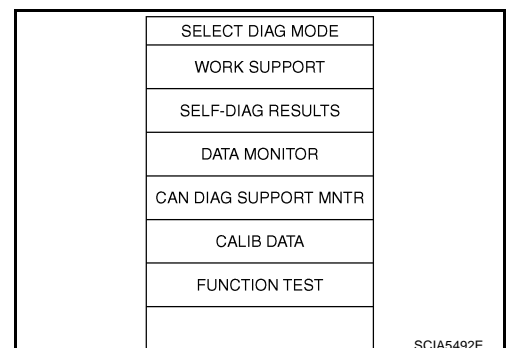

DTC P0730 BELT DAMAGE

Diagnostic Procedure

ECS00F82

1. CHECK DTC

Perform "DTC Confirmation Procedure". Refer to [CVT-99, "DTC Confirmation Procedure"](#) .

Are any DTC displayed?

YES - 1>> DTC except for "P0730 BELT DAMG" is displayed: Go to Check the DTC detected item. Refer to [CVT-58, "SELF-DIAGNOSTIC RESULT MODE"](#) .

YES - 2>> DTC for "P0730 BELT DAMG" is displayed: Replace the transaxle assembly. Refer to [CVT-226, "Removal and Installation"](#) .

NO >> **INSPECTION END**

DTC P0740 TORQUE CONVERTER CLUTCH SOLENOID VALVE

DTC P0740 TORQUE CONVERTER CLUTCH SOLENOID VALVE

PFP:31940

Description

ECS00F83

- The torque converter clutch solenoid valve is activated by the TCM in response to signals sent from the vehicle speed and throttle position sensors. Lock-up piston operation will then be controlled.
- Lock-up operation, however, is prohibited when CVT fluid temperature is too low.
- When the accelerator pedal is depressed (less than 2/8) in lock-up condition, the engine speed should not change abruptly. If there is a big jump in engine speed, there is no lock-up.

CONSULT-II Reference Value

ECS00F84

Remarks: Specification data are reference values.

Item name	Condition	Display value (Approx.)
ISOLT1	Lock-up "OFF"	0.0A
	Lock-up "ON"	0.7A

On Board Diagnosis Logic

ECS00F85

- This is an OBD-II self-diagnostic item.
- Diagnostic trouble code "P0740 TCC SOLENOID/CIRC" with CONSULT-II is detected under the following conditions.
 - TCM detects an improper voltage drop when it tries to operate the solenoid valve.

Possible Cause

ECS00F86

- Torque converter clutch solenoid valve
- Harness or connectors
(Solenoid circuit is open or shorted.)

DTC Confirmation Procedure

ECS00F87

CAUTION:

Always drive vehicle at a safe speed.

NOTE:

If "DTC Confirmation Procedure" has been previously performed, always turn ignition switch OFF and wait at least 10 seconds before performing the next test.

After the repair, touch "ERASE" on "SELF-DIAG RESULTS" and then perform the following procedure to confirm the malfunction is eliminated.

WITH CONSULT-II

1. Turn ignition switch ON. (Do not start engine.)
2. Select "DATA MONITOR" mode for "TRANSMISSION" with CONSULT-II and wait at least 10 consecutive seconds.
3. If DTC is detected, go to [CVT-103, "Diagnostic Procedure"](#).

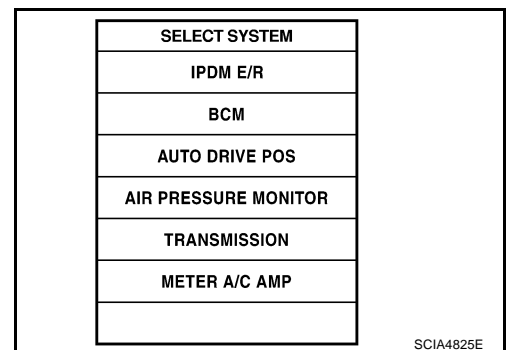

WITH GST



Follow the procedure "WITH CONSULT-II".

DTC P0740 TORQUE CONVERTER CLUTCH SOLENOID VALVE

Wiring Diagram — CVT — TCV

ECS00F88

CVT-TCV-01

- : DETECTABLE LINE FOR DTC
- : NON-DETECTABLE LINE FOR DTC
-  : LHD MODELS
-  : RHD MODELS

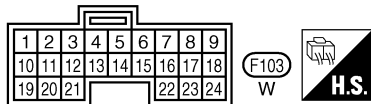
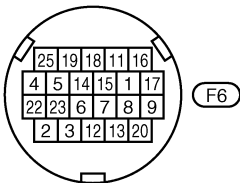
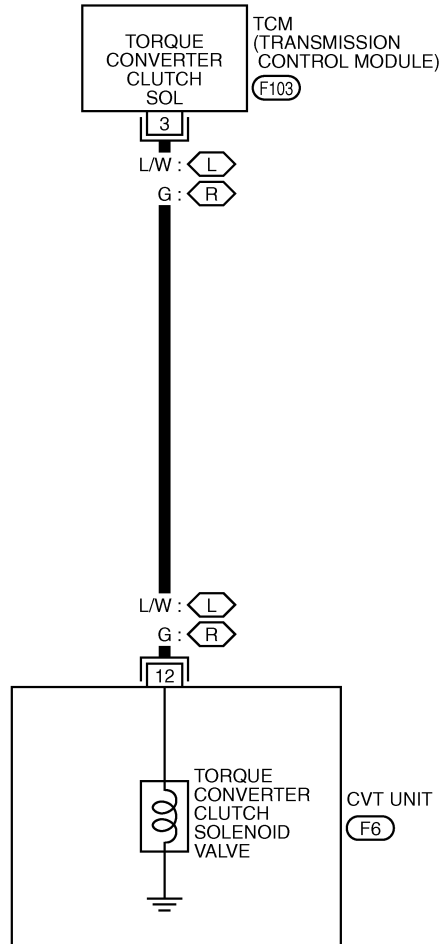

TCWB0140E

DTC P0740 TORQUE CONVERTER CLUTCH SOLENOID VALVE

TCM terminal data are reference values, measured between each terminal and ground.

Terminal	Wire color	Item	Condition	Data (Approx.)	
3	L/W*1 G*2	Torque converter clutch solenoid valve	When vehicle cruises in "D" position.	When CVT performs lock-up.	6.0V
				When CVT does not perform lock-up.	1.0V

*1: LHD models.

*2: RHD models.

Diagnostic Procedure

ECS00F89

1. CHECK INPUT SIGNAL

With CONSULT-II

- Start engine.
- Select "MAIN SIGNALS" in "DATA MONITOR" mode for "TRANSMISSION" with CONSULT-II.
- Start vehicle and read out the value of "ISOLT1".

Item name	Condition	Display value (Approx.)
ISOLT1	Lock-up "OFF"	0.0A
	Lock-up "ON"	0.7A

DATA MONITOR	
MONITOR	NO. DTC
ATF TEMP	59
STM STEP	4step
ISOL T1	0.000A
ISOL T2	0.800A
ISOL T3	0.800A
▼	
RECORD	
MODE	BACK LIGHT COPY

SCIA2349E

Without CONSULT-II

- Start engine.
- Check voltage between TCM connector terminal and ground.

Name	Connector	Terminal	Condition	Voltage (Approx.)
Torque converter clutch solenoid valve	F103	3 - ground	When vehicle cruises in "D" position.	Lock-up "OFF" 6.0V
			Lock-up "ON" 1.0V	

OK or NG

- OK >> GO TO 5.
NG >> GO TO 2.

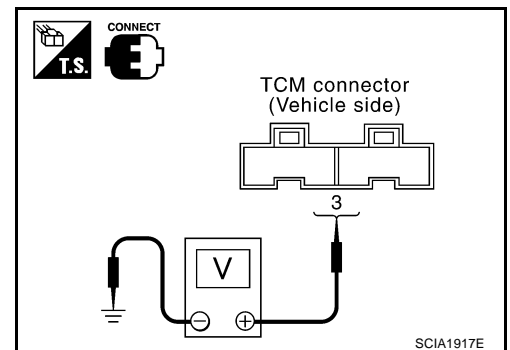

2. CHECK TORQUE CONVERTER CLUTCH SOLENOID VALVE CIRCUIT

- Turn ignition switch OFF.
- Disconnect TCM connector.
- Check resistance between TCM connector terminal and ground.

Solenoid valve	Connector	Terminal	Resistance (Approx.)
Torque converter clutch solenoid valve	F103	3 - Ground	3 - 9 Ω

- Disconnect TCM connector.
- Check if there is continuity between the connector terminal and ground.

OK or NG

- OK >> GO TO 5.
NG >> GO TO 3.

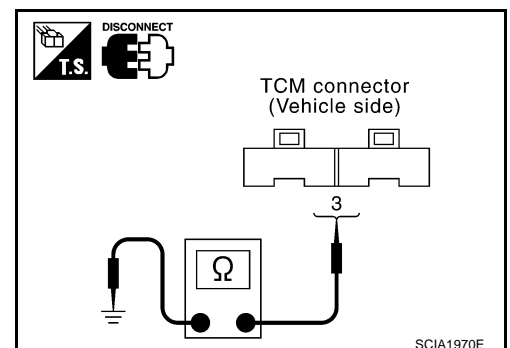

DTC P0740 TORQUE CONVERTER CLUTCH SOLENOID VALVE

3. CHECK HARNESS BETWEEN TCM AND TORQUE CONVERTER CLUTCH SOLENOID VALVE

1. Turn ignition switch OFF.
2. Disconnect TCM connector and CVT unit harness connector.
3. Check continuity between TCM connector terminal and CVT unit harness connector terminal.

Item	Connector	Terminal	Continuity
TCM	F103	3	Yes
CVT unit harness connector	F6	12	

4. If OK, check harness for short to ground and short to power.
5. If OK, check continuity between ground and CVT assembly.
6. Reinstall any part removed.

OK or NG

- OK >> GO TO 4.
 NG >> Repair or replace damaged parts.

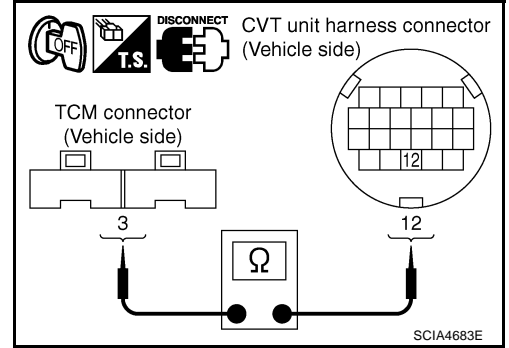

4. CHECK VALVE RESISTANCE

1. Turn ignition switch OFF.
2. Disconnect CVT unit harness connector.
3. Check resistance between CVT unit harness connector terminal and ground.

Solenoid Valve	Connector	Terminal	Resistance (Approx.)
Torque converter clutch solenoid valve	F6	12 - Ground	3 - 9 Ω

OK or NG

- OK >> GO TO 5.
 NG >> Repair or replace damaged parts.

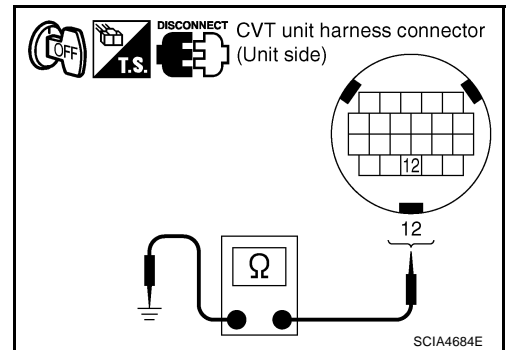

5. CHECK DTC

Perform "DTC Confirmation Procedure". Refer to [CVT-101, "DTC Confirmation Procedure"](#).

OK or NG

- OK >> **INSPECTION END**
 NG >> GO TO 6.

6. CHECK TCM

1. Check TCM input/output signal. Refer to [CVT-50, "TCM Input/Output Signal Reference Values"](#).
2. If NG, re-check TCM pin terminals for damage or loose connection with harness connector.

OK or NG

- OK >> **INSPECTION END**
 NG >> Repair or replace damaged parts.

DTC P0740 TORQUE CONVERTER CLUTCH SOLENOID VALVE

ECS00F8A

Component Inspection

TORQUE CONVERTER CLUTCH SOLENOID VALVE

1. Turn ignition switch OFF.
2. Disconnect CVT unit harness connector.
3. Check resistance between CVT unit harness connector terminal and ground.

Solenoid Valve	Connector	Terminal	Resistance (Approx.)
Torque converter clutch solenoid valve	F6	12 - Ground	3 - 9 Ω

4. If NG, replace the transaxle assembly. Refer to [CVT-226](#), "[Removal and Installation](#)".

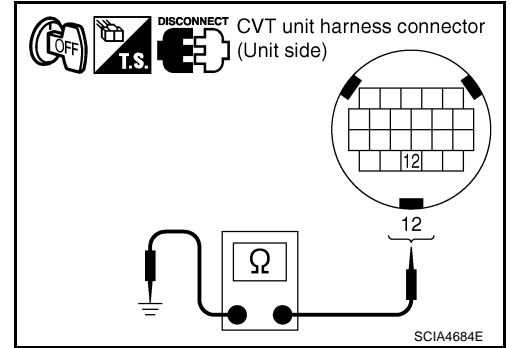

A
B
CVT
D
E
F
G
H
I
J
K
L
M

DTC P0744 A/T TCC S/V FUNCTION (LOCK-UP)

DTC P0744 A/T TCC S/V FUNCTION (LOCK-UP)

PDF:31940

Description

ECS00F8B

This malfunction is detected when the torque converter clutch does not lock-up as instructed by the TCM. This is not only caused by electrical malfunction (circuits open or shorted), but also by mechanical malfunction such as control valve sticking, improper solenoid valve operation, etc.

CONSULT-II Reference Value

ECS00F8C

Remarks: Specification data are reference values.

Item name	Condition	Display value
ENG SPEED SIG	Engine running	Closely matches the tachometer reading.
PRI SPEED SEN	During driving (lock-up ON)	Approximately matches the engine speed.

On Board Diagnosis Logic

ECS00F8D

- This is an OBD-II self-diagnostic item.
- Diagnostic trouble code "P0744 A/T TCC S/V FNCTN" with CONSULT-II is detected under the following conditions.
 - When CVT cannot perform lock-up even if electrical circuit is good.
 - When TCM compares difference value with slip revolution and detects an irregularity.

Possible Cause

ECS00F8E

- Torque converter clutch solenoid valve
- Hydraulic control circuit

DTC Confirmation Procedure

ECS00F8F

CAUTION:

Always drive vehicle at a safe speed.

NOTE:

If "DTC Confirmation Procedure" has been previously performed, always turn ignition switch OFF and wait at least 10 seconds before performing the next test.

After the repair, touch "ERASE" on "SELF-DIAG RESULTS" and then perform the following procedure to confirm the malfunction is eliminated.

④ WITH CONSULT-II

1. Turn ignition switch ON. (Do not start engine.)
2. Select "DATA MONITOR" mode for "TRANSMISSION" with CONSULT-II.
3. Start engine and maintain the following condition for at least 30 seconds.
ACC PEDAL OPEN: More than 1.0/8
Selector lever: "D" position
[Vehicle speed: Constant speed of more than 40 km/h (25 MPH)]
4. If DTC is detected go to [CVT-107, "Diagnostic Procedure"](#).

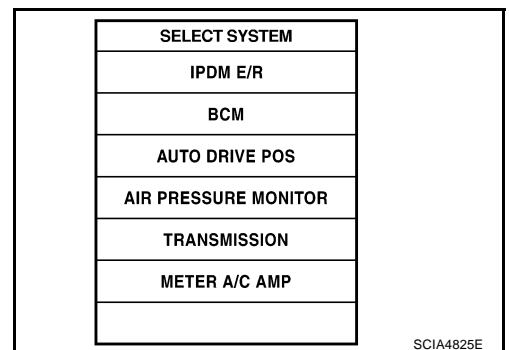

SCIA4825E

④ WITH GST

Follow the procedure "WITH CONSULT-II".

DTC P0744 A/T TCC S/V FUNCTION (LOCK-UP)

ECS00F8G

Diagnostic Procedure

1. CHECK INPUT SIGNALS

With CONSULT-II

1. Start engine.
2. Select "ECU INPUT SIGNALS" in "DATA MONITOR" mode for "TRANSMISSION" with CONSULT-II.
3. Start vehicle.
4. Check if there is a great difference between "ENG SPEED SIG" and "PRI SPEED SEN". (Lock-up ON.)

Item name	Condition	Display value
ENG SPEED SIG	Engine running	Closely matches the tachometer reading.
PRI SPEED SEN	During driving (lock-up ON)	Approximately matches the engine speed.

DATA MONITOR	
MONITOR	NO DTC
VSP SENSOR	1 km / h
ESTM VSP SIG	0 km / h
PRI SPEED SEN	32 rpm
ENG SPEED SIG	0 rpm
SEC HYDR SEN	0.47 V

▼	
RECORD	
MODE	BACK
LIGHT	COPY

SCIA2279E

OK or NG

- OK >> GO TO 5.
NG >> GO TO 2.

2. CHECK LINE PRESSURE

Perform line pressure test. Refer to [CVT-39, "LINE PRESSURE TEST"](#).

OK or NG

- OK >> GO TO 3.
NG >> Repair or replace damaged parts. Refer to [CVT-40, "Judgement of Line Pressure Test"](#).

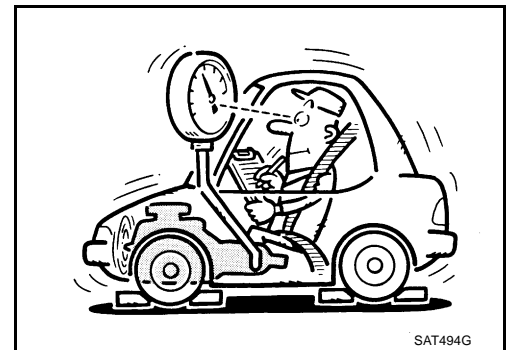

3. DETECT MALFUNCTIONING ITEM

Check the following:

- Torque converter clutch solenoid valve. Refer to [CVT-105, "Component Inspection"](#).
- Lock-up select solenoid valve. Refer to [CVT-167, "Component Inspection"](#).

OK or NG

- OK >> GO TO 4.
NG >> Repair or replace damaged parts.

4. CHECK SECONDARY SPEED SENSOR SYSTEM AND PRIMARY SPEED SENSOR SYSTEM

Check output speed sensor (secondary speed sensor) system and input speed sensor (primary speed sensor) system. Refer to [CVT-91, "DTC P0720 VEHICLE SPEED SENSOR CVT \(SECONDARY SPEED SENSOR\)"](#), [CVT-86, "DTC P0715 INPUT SPEED SENSOR CIRCUIT \(PRI SPEED SENSOR\)"](#).

OK or NG

- OK >> GO TO 5.
NG >> Repair or replace damaged parts.

DTC P0744 A/T TCC S/V FUNCTION (LOCK-UP)

5. CHECK DTC

Perform "DTC Confirmation Procedure". Refer to [CVT-106, "DTC Confirmation Procedure"](#) .

OK or NG

OK >> **INSPECTION END**
NG >> GO TO 6.

6. CHECK TCM

1. Check TCM input/output signal. Refer to [CVT-50, "TCM Input/Output Signal Reference Values"](#) .
2. If NG, re-check TCM pin terminals for damage or loose connection with harness connector.

OK or NG

OK >> **INSPECTION END**
NG >> 1. Repair or replace damaged parts.
2. Replace the transaxle assembly. Refer to [CVT-226, "Removal and Installation"](#) .

DTC P0745 LINE PRESSURE SOLENOID VALVE

DTC P0745 LINE PRESSURE SOLENOID VALVE

PFP:31940

Description

ECS00F8H

The pressure control solenoid valve A (line pressure solenoid valve) regulates the oil pump discharge pressure to suit the driving condition in response to a signal sent from the TCM.

CONSULT-II Reference Value

ECS00F8I

Remarks: Specification data are reference values.

Item name	Condition	Display value (Approx.)
ISOLT2	Release your foot from the accelerator pedal.	0.8A
	Press the accelerator pedal all the way down.	0.0A

On Board Diagnosis Logic

ECS00F8J

- This is an OBD-II self-diagnostic item.
- Diagnostic trouble code "P0745 L/PRESS SOL/CIRC" with CONSULT-II is detected under the following conditions.
 - TCM detects an improper voltage drop when it tries to operate the solenoid valve.
 - When TCM compares target value with monitor value and detects an irregularity.

Possible Cause

ECS00F8K

- Harness or connectors
(Solenoid circuit is open or shorted.)
- Pressure control solenoid valve A (Line pressure solenoid valve)

DTC Confirmation Procedure

ECS00F8L

NOTE:

If "DTC Confirmation Procedure" has been previously performed, always turn ignition switch OFF and wait at least 10 seconds before performing the next test.

After the repair, perform the following procedure to confirm the malfunction is eliminated.

WITH CONSULT-II

1. Turn ignition switch ON and select "DATA MONITOR" mode for "ENGINE" with CONSULT-II.
2. Start engine and wait at least 5 seconds.
3. If DTC is detected, go to [CVT-111, "Diagnostic Procedure"](#).

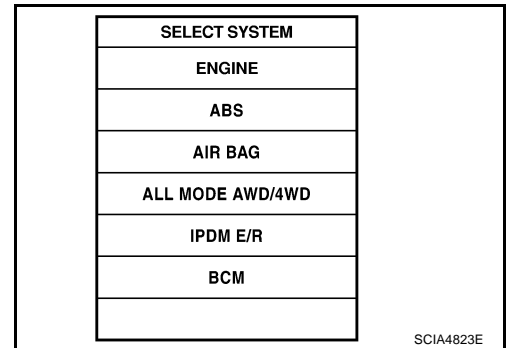

WITH GST

Follow the procedure "WITH CONSULT-II".

DTC P0745 LINE PRESSURE SOLENOID VALVE

Wiring Diagram — CVT — LPSV

EC500F8M

CVT-LPSV-01

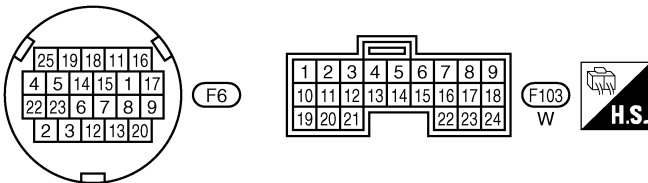
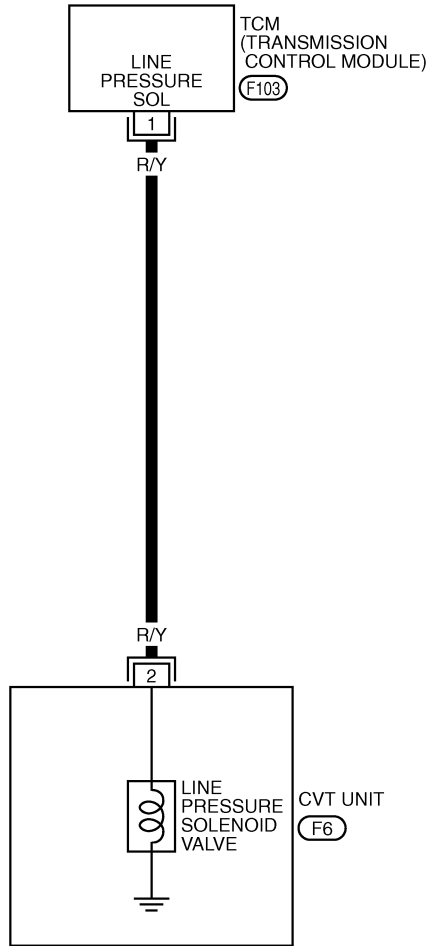

— : DETECTABLE LINE FOR DTC
— : NON-DETECTABLE LINE FOR DTC



TCWA0249E

DTC P0745 LINE PRESSURE SOLENOID VALVE

TCM terminal data are reference values, measured between each terminal and ground.

Terminal	Wire color	Item	Condition	Data (Approx.)	
1	R/Y	Pressure control solenoid valve A (Line pressure solenoid valve)	 and 	Release your foot from the accelerator pedal.	5.0 - 7.0V
				Press the accelerator pedal all the way down.	1.0 - 3.0V

Diagnostic Procedure

1. CHECK INPUT SIGNAL

ECS00F8N

With CONSULT-II

- Start engine.
- Select "MAIN SIGNALS" in "DATA MONITOR" mode for "TRANSMISSION" with CONSULT-II.
- Read out the value of "ISOLT2".

Item name	Condition	Display value (Approx.)
ISOLT2	Release your foot from the accelerator pedal.	0.8A
	Press the accelerator pedal all the way down.	0.0A

DATA MONITOR	
MONITOR	NO DTC
ATF TEMP	59
STM STEP	4step
ISOL T1	0.000A
ISOL T2	0.800A
ISOL T3	0.800A
▼	
RECORD	
MODE	BACK LIGHT COPY

SCIA2349E

Without CONSULT-II

- Start engine.
- Check voltage between TCM connector terminal and ground.

Name	Connector	Terminal	Condition	Voltage (Approx.)
Pressure control solenoid valve A (Line pressure solenoid valve)	F103	1 - ground	Release your foot from the accelerator pedal.	5.0 - 7.0V
			Press the accelerator pedal all the way down.	1.0 - 3.0V

- Turn ignition switch OFF.
- Disconnect TCM connector.
- Check if there is continuity between connector terminal and ground.

OK or NG

- OK >> GO TO 5.
 NG >> GO TO 2.

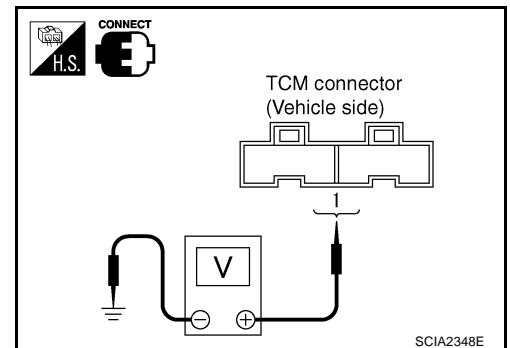

DTC P0745 LINE PRESSURE SOLENOID VALVE

2. CHECK PRESSURE CONTROL SOLENOID VALVE A (LINE PRESSURE SOLENOID VALVE) CIRCUIT

1. Turn ignition switch OFF.
2. Disconnect TCM connector.
3. Check resistance between TCM connector terminal and ground.

Solenoid valve	Connector	Terminal	Resistance (Approx.)
Pressure control solenoid valve A (Line pressure solenoid valve)	F103	1 - ground	3 - 9 Ω

OK or NG

- OK >> GO TO 5.
 NG >> GO TO 3.

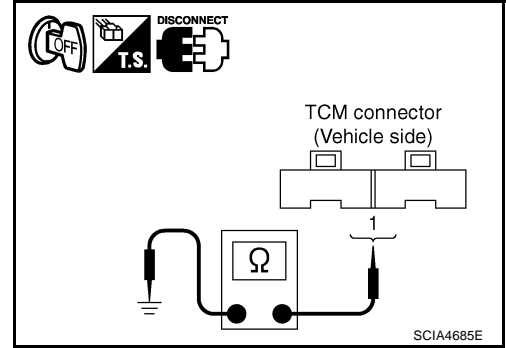

3. CHECK VALVE RESISTANCE

1. Turn ignition switch OFF.
2. Disconnect CVT unit harness connector.
3. Check resistance between CVT unit harness connector terminal and ground.

Solenoid valve	Connector	Terminal	Resistance (Approx.)
Pressure control solenoid valve A (Line pressure solenoid valve)	F6	2 - Ground	3 - 9 Ω

OK or NG

- OK >> GO TO 4.
 NG >> Replace the transaxle assembly. Refer to [CVT-226](#), "Removal and Installation".

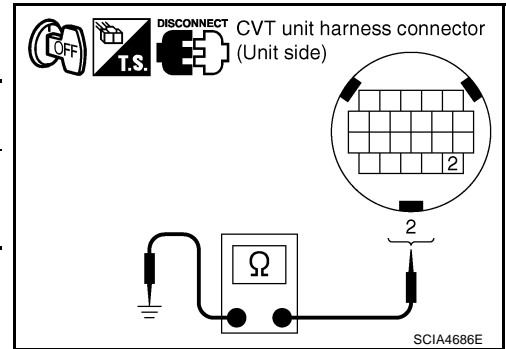

4. CHECK HARNESS BETWEEN TCM AND PRESSURE CONTROL SOLENOID VALVE A (LINE PRESSURE SOLENOID VALVE)

1. Turn ignition switch OFF.
2. Disconnect CVT unit harness connector and TCM connector.
3. Check continuity between TCM connector terminal and CVT unit harness connector terminal.

Item	Connector	Terminal	Continuity
TCM	F103	1	Yes
CVT unit harness connector	F6	2	

4. If OK, check harness for short to ground and short to power.
5. If OK, check continuity between ground and CVT assembly.
6. Reinstall any part removed.

OK or NG

- OK >> GO TO 5.
 NG >> Repair open circuit or short to ground or short to power in harness or connectors.

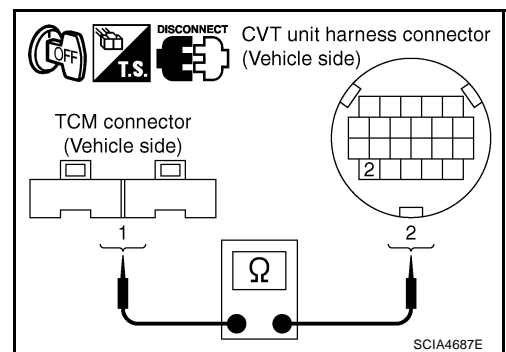

DTC P0745 LINE PRESSURE SOLENOID VALVE

5. CHECK DTC

Perform "DTC Confirmation Procedure". Refer to [CVT-109, "DTC Confirmation Procedure"](#) .

OK or NG

- OK >> **INSPECTION END**
- NG >> GO TO 6.

6. CHECK TCM

1. Check TCM input/output signal. Refer to [CVT-50, "TCM Input/Output Signal Reference Values"](#) .
2. If NG, re-check TCM pin terminals for damage or loose connection with harness connector.

OK or NG

- OK >> **INSPECTION END**
- NG >> 1. Repair or replace damaged parts.
2. Replace the transaxle assembly. Refer to [CVT-226, "Removal and Installation"](#) .

Component Inspection

PRESSURE CONTROL SOLENOID VALVE A (LINE PRESSURE SOLENOID VALVE)

EC500F80

1. Turn ignition switch OFF.
2. Disconnect CVT unit harness connector.
3. Check resistance between CVT unit harness connector terminal and ground.

Solenoid valve	Connector	Terminal	Resistance (Approx.)
Pressure control solenoid valve A (Line pressure solenoid valve)	F6	2 - Ground	3 - 9 Ω

4. If NG, replace the transaxle assembly. Refer to [CVT-226, "Removal and Installation"](#) .

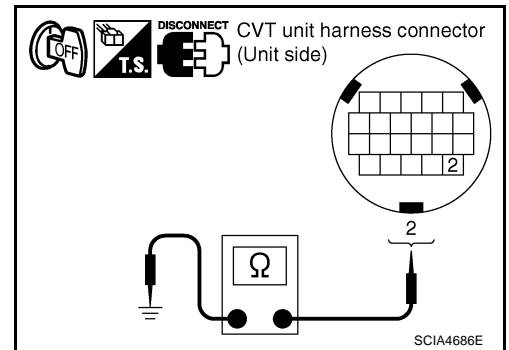

DTC P0746 PRESSURE CONTROL SOLENOID A PERFORMANCE (LINE PRESSURE SOLENOID VALVE)

DTC P0746 PRESSURE CONTROL SOLENOID A PERFORMANCE (LINE PRESSURE SOLENOID VALVE)

PFP:31941

Description

ECS00F8P

The pressure control solenoid valve A (line pressure solenoid valve) regulates the oil pump discharge pressure to suit the driving condition in response to a signal sent from the TCM.

CONSULT-II Reference Value

ECS00F8Q

Remarks: Specification data are reference values.

Item name	Condition	Display value (Approx.)
PRI PRESS	"N" position idle	0.3 - 0.9MPa

On Board Diagnosis Logic

ECS00F8R

- This is an OBD-II self-diagnostic item.
- Diagnostic trouble code "P0746 PRS CNT SOL/A FCTN" with CONSULT-II is detected under the following conditions.
 - Unexpected gear ratio was detected in the LOW side due to excessively low line pressure.

Possible Cause

ECS00F8S

- Line pressure control system
- Output speed sensor (Secondary speed sensor)
- Input speed sensor (Primary speed sensor)

DTC Confirmation Procedure

ECS00F8T

CAUTION:

- Always drive vehicle at a safe speed.
- Be careful not to rev engine into the red zone on the tachometer.

NOTE:

If "DTC Confirmation Procedure" has been previously performed, always turn ignition switch OFF and wait at least 5 seconds before performing the next test.

After the repair, touch "ERASE" on "SELF-DIAG RESULTS" and then perform the following procedure to confirm the malfunction is eliminated.

WITH CONSULT-II

1. Turn ignition switch ON and select "DATA MONITOR" mode for "TRANSMISSION" with CONSULT-II.

2. Start engine and maintain the following conditions for at least 10 consecutive seconds. Test start from 0 km/h (0 MPH).

ATF TEMP SEN: 1.0 - 2.0V

ACC PEDAL OPEN: More than 1.0/8

Selector lever: "D" position

VHCL SPEED: 10 km/h (6 MPH) More than

Driving location: Driving the vehicle uphill (increased engine load) will help maintain the driving conditions required for this test.

3. If DTC is detected, go to [CVT-115, "Diagnostic Procedure"](#).

WITH GST

Follow the procedure "WITH CONSULT-II".

SELECT SYSTEM
IPDM E/R
BCM
AUTO DRIVE POS
AIR PRESSURE MONITOR
TRANSMISSION
METER A/C AMP

SCIA4825E

DTC P0746 PRESSURE CONTROL SOLENOID A PERFORMANCE (LINE PRESSURE SOLENOID VALVE)

EC500F8U

Diagnostic Procedure

1. CHECK INPUT SIGNAL

With CONSULT-II

1. Start engine.
2. Select "MAIN SIGNALS" in "DATA MONITOR" mode for "TRANSMISSION" with CONSULT-II.
3. Start vehicle and read out the value of "PRI PRESS".

Item name	Condition	Display value (Approx.)
PRI PRESS	"N" position idle	0.3 - 0.9MPa

DATA MONITOR	
MONITOR	NO DTC
GEAR RATIO	2.37
ACC PEDAL OPEN	0.0 / 8
VENG TRQ	217.6 Nm
SEC PRESS	0.000 MPa
PRI PRESS	0.000 MPa

Δ	▽
RECORD	
MODE	BACK
LIGHT	COPY

SCIA2366E

Without CONSULT-II

1. Start engine.
2. Check voltage between TCM connector terminal and ground.

Name	Connector	Terminal	Condition	Voltage (Approx.)
Transmission fluid pressure sensor B (Primary pressure sensor)	F104	41 - Ground	"N" position idle	0.7 - 3.5V

OK or NG

- OK >> GO TO 5.
 NG >> GO TO 2.

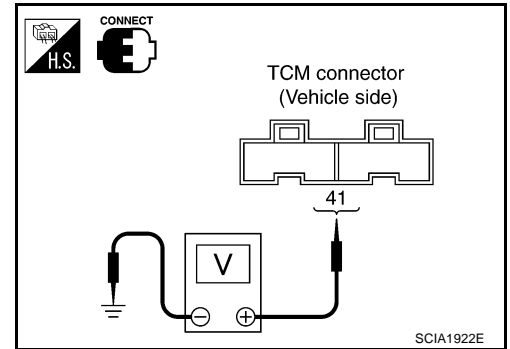

2. CHECK LINE PRESSURE

Perform line pressure test. Refer to [CVT-39, "LINE PRESSURE TEST"](#).

OK or NG

- OK >> GO TO 3.
 NG >> Repair or replace damaged parts. Refer to [CVT-40, "Judgement of Line Pressure Test"](#).

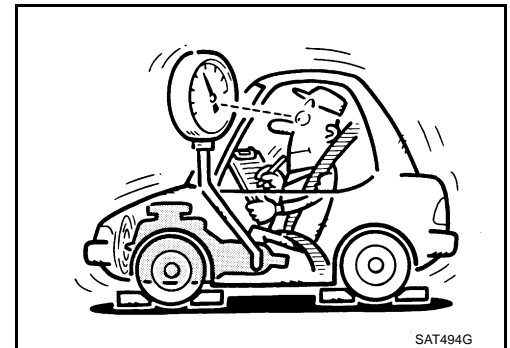

3. DETECT MALFUNCTIONING ITEM

Check the following:

- Pressure control solenoid valve A (line pressure solenoid valve). Refer to [CVT-113, "Component Inspection"](#).

OK or NG

- OK >> GO TO 4.
 NG >> Repair or replace damaged parts.

DTC P0746 PRESSURE CONTROL SOLENOID A PERFORMANCE (LINE PRESSURE SOLENOID VALVE)

4. CHECK OUTPUT SPEED SENSOR (SECONDARY SPEED SENSOR) SYSTEM AND INPUT SPEED SENSOR (PRIMARY SPEED SENSOR) SYSTEM

Check output speed sensor (secondary speed sensor) system and input speed sensor (primary speed sensor) system. Refer to [CVT-91, "DTC P0720 VEHICLE SPEED SENSOR CVT \(SECONDARY SPEED SENSOR\)"](#) , [CVT-86, "DTC P0715 INPUT SPEED SENSOR CIRCUIT \(PRI SPEED SENSOR\)"](#) .

OK or NG

- OK >> GO TO 5.
- NG >> Repair or replace damaged parts.

5. DETECT MALFUNCTIONING ITEM

Check the following:

- Power supply and ground circuit for TCM. Refer to [CVT-149, "Wiring Diagram — CVT — POWER \(LHD Models\)"](#) , [CVT-151, "Wiring Diagram — CVT — POWER \(RHD Models\)"](#) .
- The TCM pin terminals for damage or loose connection with harness connector.

OK or NG

- OK >> GO TO 6.
- NG >> Repair or replace damaged parts.

6. CHECK DTC

Perform "DTC Confirmation Procedure". Refer to [CVT-114, "DTC Confirmation Procedure"](#) .

OK or NG

- OK >> **INSPECTION END**
- NG >> Replace the transaxle assembly or TCM. Refer to [CVT-226, "Removal and Installation"](#) .

DTC P0776 PRESSURE CONTROL SOLENOID B PERFORMANCE (SEC PRESSURE SOLENOID VALVE)

DTC P0776 PRESSURE CONTROL SOLENOID B PERFORMANCE (SEC PRESSURE SOLENOID VALVE)

PFP:31941

Description

ECS00F8V

The pressure control solenoid valve B (secondary pressure solenoid valve) regulates the secondary pressure to suit the driving condition in response to a signal sent from the TCM.

CONSULT-II Reference Value

ECS00F8W

Remarks: Specification data are reference values.

Item name	Condition	Display value (Approx.)
SEC PRESS	"N" position idle	0.5 - 0.9MPa

On Board Diagnosis Logic

ECS00F8X

- This is an OBD-II self-diagnostic item.
- Diagnostic trouble code "P0776 PRS CNT SOL/B FCTN" with CONSULT-II is detected when secondary pressure is too high or too low compared with the commanded value while driving.

Possible Cause

ECS00F8Y

- Harness or connectors (Solenoid circuit is open or shorted.)
- Pressure control solenoid valve B (Secondary pressure solenoid valve system)
- Transmission fluid pressure sensor A (Secondary pressure sensor)
- Line pressure control system

DTC Confirmation Procedure

ECS00F8Z

CAUTION:

- Always drive vehicle at a safe speed.
- Be careful not to rev engine into the red zone on the tachometer.

NOTE:

If "DTC Confirmation Procedure" has been previously performed, always turn ignition switch OFF and wait at least 5 seconds before performing the next test.

After the repair, perform the following procedure to confirm the malfunction is eliminated.

WITH CONSULT-II

1. Turn ignition switch ON and select "DATA MONITOR" mode for "TRANSMISSION" with CONSULT-II.
2. Start engine and maintain the following conditions for at least 30 consecutive seconds.

ATF TEMP SEN: 1.0 - 2.0V

ACC PEDAL OPEN: More than 1.0/8

Selector lever: "D" position

VHCL SPEED: 10 km/h (6 MPH) More than

Driving location: Driving the vehicle uphill (increased engine load) will help maintain the driving conditions required for this test.

3. If DTC is detected, go to [CVT-118, "Diagnostic Procedure"](#).

WITH GST

Follow the procedure "WITH CONSULT-II".

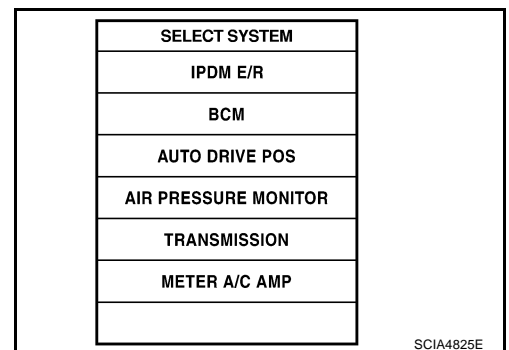

DTC P0776 PRESSURE CONTROL SOLENOID B PERFORMANCE (SEC PRESSURE SOLENOID VALVE)

ECS00F90

Diagnostic Procedure

1. CHECK INPUT SIGNAL

With CONSULT-II

1. Start engine.
2. Select "MAIN SIGNALS" in "DATA MONITOR" mode for "TRANSMISSION" with CONSULT-II.
3. Start vehicle and read out the value of "SEC PRESS".

Item name	Condition	Display value (Approx.)
SEC PRESS	"N" position idle	0.5 - 0.9MPa

OK or NG

- OK >> GO TO 5.
NG >> GO TO 2.

DATA MONITOR	
MONITOR	NO. DTC
GEAR RATIO	2.37
ACC PEDAL OPEN	0.0 / 8
VENG TRQ	217.6 Nm
SEC PRESS	0.000 MPa
PRI PRESS	0.000 MPa

△		▽	
RECORD			
MODE	BACK	LIGHT	COPY

SCIA2366E

2. CHECK LINE PRESSURE

Perform line pressure test. Refer to [CVT-39, "LINE PRESSURE TEST"](#).

OK or NG

- OK >> GO TO 3.
NG >> Repair or replace damaged parts. Refer to [CVT-40, "Judgement of Line Pressure Test"](#).

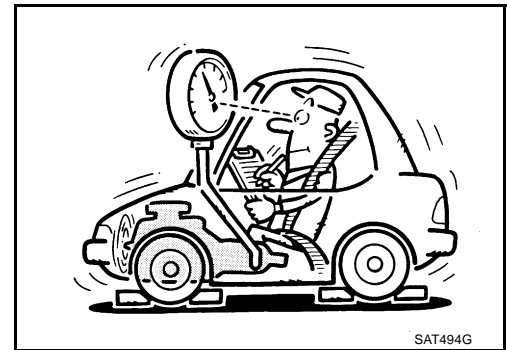

3. DETECT MALFUNCTIONING ITEM

Check the following:

- Pressure control solenoid valve B (Secondary pressure solenoid valve). Refer to [CVT-124, "Component Inspection"](#).
- Pressure control solenoid valve A (Line pressure solenoid valve). Refer to [CVT-113, "Component Inspection"](#).

OK or NG

- OK >> GO TO 4.
NG >> Repair or replace damaged parts.

4. CHECK SECONDARY PRESSURE SENSOR SYSTEM

Check transmission fluid pressure sensor A (secondary pressure sensor) system. Refer to [CVT-132, "DTC P0840 TRANSMISSION FLUID PRESSURE SENSOR A CIRCUIT \(SEC PRESSURE SENSOR\)"](#).

OK or NG

- OK >> GO TO 5.
NG >> Repair or replace damaged parts.

DTC P0776 PRESSURE CONTROL SOLENOID B PERFORMANCE (SEC PRESSURE SOLENOID VALVE)

5. DETECT MALFUNCTIONING ITEM

Check the following:

- Power supply and ground circuit for TCM. Refer to [CVT-149, "Wiring Diagram — CVT — POWER \(LHD Models\)"](#) , [CVT-151, "Wiring Diagram — CVT — POWER \(RHD Models\)"](#) .
- The TCM pin terminals for damage or loose connection with harness connector.

OK or NG

- OK >> GO TO 6.
- NG >> Repair or replace damaged parts.

6. CHECK DTC

Perform "DTC Confirmation Procedure". Refer to [CVT-117, "DTC Confirmation Procedure"](#) .

OK or NG

- OK >> **INSPECTION END**
- NG >> Replace the transaxle assembly. Refer to [CVT-226, "Removal and Installation"](#) .

A
B
CVT
D
E
F
G
H
I
J
K
L
M

DTC P0778 PRESSURE CONTROL SOLENOID B ELECTRICAL (SEC PRESSURE SOLENOID VALVE)

DTC P0778 PRESSURE CONTROL SOLENOID B ELECTRICAL (SEC PRESSURE SOLENOID VALVE)

PF3:31941

Description

ECS00F91

The pressure control solenoid valve B (secondary pressure solenoid valve) regulates the oil pump discharge pressure to suit the driving condition in response to a signal sent from the TCM.

CONSULT-II Reference Value

ECS00F92

Remarks: Specification data are reference values.

Item name	Condition	Display value (Approx.)
ISOLT3	Secondary pressure low - Secondary pressure high	0.8 - 0.0A
SOLMON3	"N" position idle	0.6 - 0.7A
	When stalled	0.4 - 0.6A

On Board Diagnosis Logic

ECS00F93

- This is an OBD-II self-diagnostic item.
- Diagnostic trouble code "P0778 PRS CNT SOL/B CIRC" with CONSULT-II is detected under the following conditions.
 - TCM detects an improper voltage drop when it tries to operate the solenoid valve.
 - When TCM compares target value with monitor value and detects an irregularity.

Possible Cause

ECS00F94

- Harness or connectors
(Solenoid circuit is open or shorted.)
- Pressure control solenoid valve B (Secondary pressure solenoid valve)

DTC Confirmation Procedure

ECS00F95

NOTE:

If "DTC Confirmation Procedure" has been previously performed, always turn ignition switch OFF and wait at least 10 seconds before performing the next test.

After the repair, perform the following procedure to confirm the malfunction is eliminated.

WITH CONSULT-II

1. Turn ignition switch ON.
2. Select "DATA MONITOR" mode for "TRANSMISSION" with CONSULT-II.
3. Start engine and wait at least 5 seconds.
4. If DTC is detected, go to [CVT-122, "Diagnostic Procedure"](#).

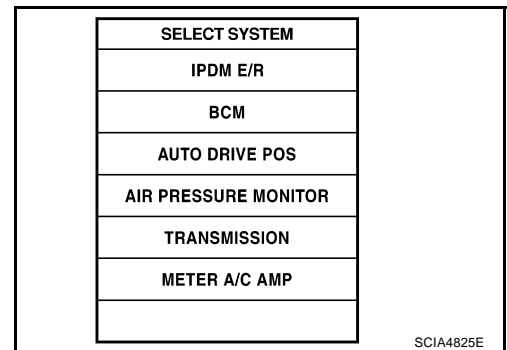

SCIA4825E

WITH GST

Follow the procedure "WITH CONSULT-II".

DTC P0778 PRESSURE CONTROL SOLENOID B ELECTRICAL (SEC PRES- SURE SOLENOID VALVE)

Wiring Diagram — CVT — SECPSV

ECS00F96

CVT-SECPSV-01

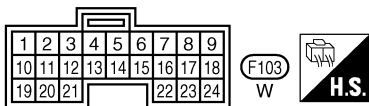
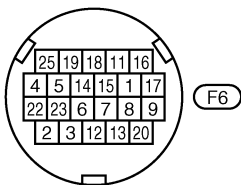
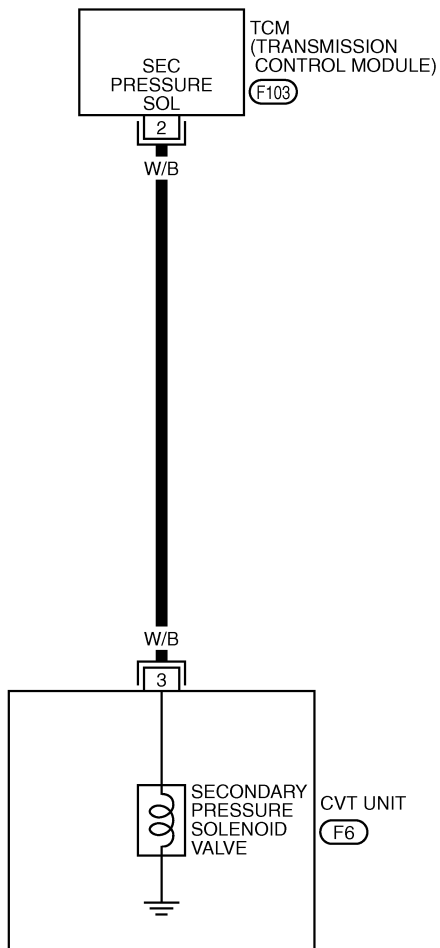

— : DETECTABLE LINE FOR DTC
— : NON-DETECTABLE LINE FOR DTC



TCWA0250E

DTC P0778 PRESSURE CONTROL SOLENOID B ELECTRICAL (SEC PRES- SURE SOLENOID VALVE)

TCM terminal data are reference values, measured between each terminal and ground.

Terminal	Wire color	Item	Condition	Data (Approx.)	
2	W/B	Pressure control solenoid valve B (Secondary pressure solenoid valve)	 and 	Release your foot from the accelerator pedal.	5.0 - 7.0V
				Press the accelerator pedal all the way down.	3.0 - 4.0V

Diagnostic Procedure

ECS00F97

1. CHECK INPUT SIGNAL

With CONSULT-II

- Start engine.
- Select "MAIN SIGNALS" in "DATA MONITOR" mode for "TRANSMISSION" with CONSULT-II.
- Read out the value of "ISOLT3".

Item name	Condition	Display value (Approx.)
ISOLT3	Secondary pressure low - Secondary pressure high	0.8 - 0.0A

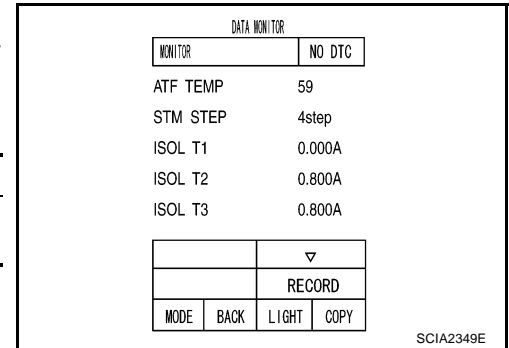

SCIA2349E

Without CONSULT-II

- Start engine.
- Check voltage between TCM connector terminal and ground.

Name	Connector	Terminal	Condition	Voltage (Approx.)
Pressure control solenoid valve B (Secondary pressure solenoid valve)	F103	2 - ground	Release your foot from the accelerator pedal.	5.0 - 7.0V
			Press the accelerator pedal all the way down.	3.0 - 4.0V

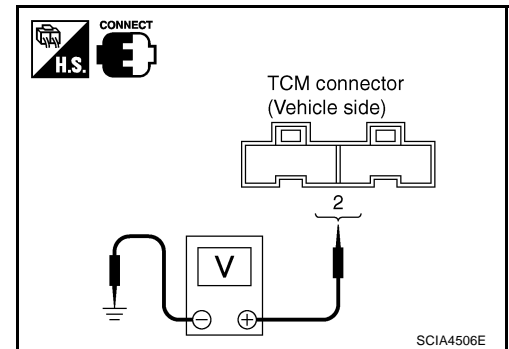

SCIA4506E

- Turn ignition switch OFF.
- Disconnect TCM connector.
- Check if there is continuity between connector terminal and ground.

OK or NG

OK >> GO TO 5.

NG >> GO TO 2.

DTC P0778 PRESSURE CONTROL SOLENOID B ELECTRICAL (SEC PRESSURE SOLENOID VALVE)

2. CHECK PRESSURE CONTROL SOLENOID VALVE A (LINE PRESSURE SOLENOID VALVE) CIRCUIT

1. Turn ignition switch OFF.
2. Disconnect TCM connector.
3. Check resistance between TCM connector terminal and ground.

Solenoid valve	Connector	Terminal	Resistance (Approx.)
Pressure control solenoid valve B (Secondary pressure solenoid valve)	F103	2 - Ground	3 - 9 Ω

OK or NG

- OK >> GO TO 5.
 NG >> GO TO 3.

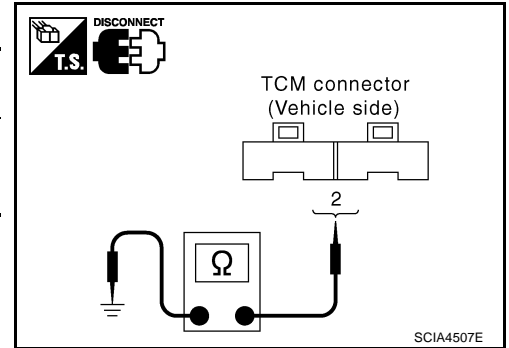

3. CHECK VALVE RESISTANCE

1. Turn ignition switch OFF.
2. Disconnect CVT unit harness connector.
3. Check resistance between CVT unit harness connector terminal and ground.

Solenoid valve	Connector	Terminal	Resistance (Approx.)
Pressure control solenoid valve B (Secondary pressure solenoid valve)	F6	3 - Ground	3 - 9 Ω

OK or NG

- OK >> GO TO 4.
 NG >> Repair or replace damaged parts.

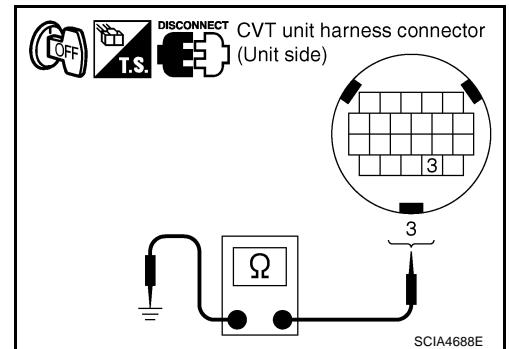

4. CHECK POWER SOURCE CIRCUIT

1. Turn ignition switch OFF.
2. Disconnect TCM connector and CVT unit harness connector.
3. Check continuity between TCM connector terminal and CVT unit harness connector terminal.

Item	Connector	Terminal	Continuity
TCM connector	F103	2	Yes
CVT unit harness connector	F6	3	

4. If OK, check harness for short to ground and short to power.
5. Reinstall any part removed.

OK or NG

- OK >> GO TO 5.
 NG >> Repair or replace damaged parts.

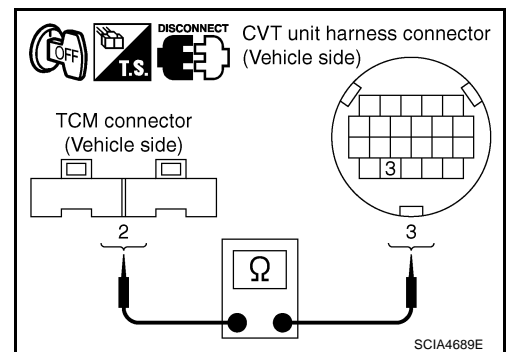

5. CHECK DTC

Perform "DTC Confirmation Procedure". Refer to [CVT-120, "DTC Confirmation Procedure"](#).

OK or NG

- OK >> **INSPECTION END**
 NG >> GO TO 6.

DTC P0778 PRESSURE CONTROL SOLENOID B ELECTRICAL (SEC PRESSURE SOLENOID VALVE)

6. CHECK TCM

1. Check TCM input/output signal. Refer to [CVT-50, "TCM Input/Output Signal Reference Values"](#) .
2. If NG, re-check TCM pin terminals for damage or loose connection with harness connector.

OK or NG

OK >> **INSPECTION END**

NG >> 1. Repair or replace damaged parts.

2. Replace the transaxle assembly. Refer to [CVT-226, "Removal and Installation"](#) .

Component Inspection

PRESSURE CONTROL SOLENOID VALVE B (SECONDARY PRESSURE SOLENOID VALVE)

ECS00F98

1. Turn ignition switch OFF.
2. Disconnect CVT unit harness connector.
3. Check resistance between CVT unit harness connector terminal and ground.

Solenoid Valve	Connector	Terminal	Resistance (Approx.)
Pressure control solenoid valve B (Secondary pressure solenoid valve)	F6	3 - Ground	3 - 9 Ω

4. If NG, replace the transaxle assembly. Refer to [CVT-226, "Removal and Installation"](#) .

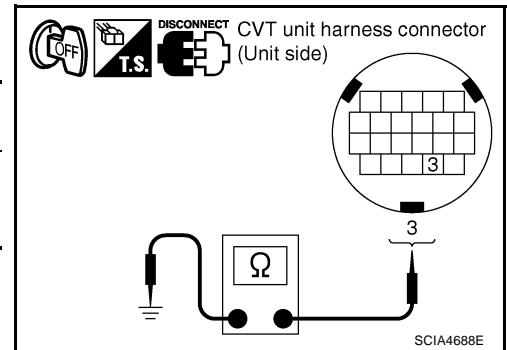

DTC P0826 MANUAL MODE SWITCH CIRCUIT

DTC P0826 MANUAL MODE SWITCH CIRCUIT

PFP:34901

Description

ECS00F99

Manual mode switch is installed in CVT control device. The manual mode switch sends shift up and shift down switch signals to TCM.

TCM sends the switch signals to unified meter and A/C amp via CAN communication line. Then manual mode switch position is indicated on the CVT position indicator. For inspection, refer to [CVT-175, "Diagnostic Procedure"](#).

CONSULT-II Reference Value

ECS00F9A

Item name	Condition	Display value
MMODE	Manual shift gate position (neutral)	ON
	Other than the above	OFF
NON MMODE	Manual shift gate position (neutral, +side, -side)	OFF
	Other than the above	ON
UPLVR	Select lever: + side	ON
	Other than the above	OFF
DOWNLVR	Select lever: - side	ON
	Other than the above	OFF

On Board Diagnosis Logic

ECS00F9B

- This is not an OBD-II self-diagnostic item.
- Diagnostic trouble code "P0826 MANUAL MODE SWITCH" with CONSULT-II is detected when TCM monitors Manual mode, Non manual mode, Up or Down switch signal, and then detects irregular with impossible input pattern for 1 second or more.

Possible Cause

ECS00F9C

- Harness or connectors
(These switches circuit is open or shorted.)
(TCM, and unified meter and A/C amp circuit are open or shorted.)
(CAN communication line is open or shorted.)
- Manual mode select switch (Built into CVT control device)
- Manual mode position select switch (Built into CVT control device)

DTC Confirmation Procedure

ECS00F9D

NOTE:

If "DTC Confirmation Procedure" has been previously conducted, always turn ignition switch OFF and wait at least 10 seconds before conducting the next test.

After the repair, perform the following procedure to confirm the malfunction is eliminated.

WITH CONSULT-II

1. Turn ignition switch ON. (Do not start engine.)
2. Select "DATA MONITOR" mode for "TRANSMISSION" with CONSULT-II.
3. Start engine.
4. Move selector lever to "M" position.
5. Drive vehicle for at least 2 consecutive seconds.
6. If DTC is detected, go to [CVT-129, "Diagnostic Procedure"](#).

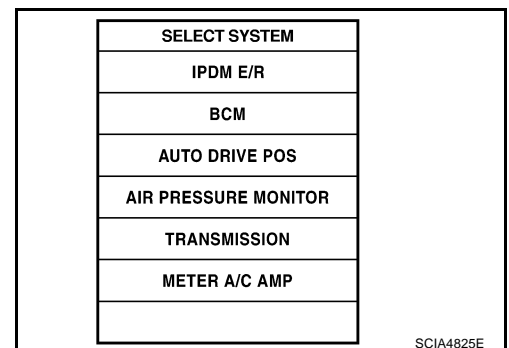

DTC P0826 MANUAL MODE SWITCH CIRCUIT

Wiring Diagram — CVT — MMSW (LHD Models)

EC500F9E

CVT-MMSW-01

REFER TO PG-POWER.

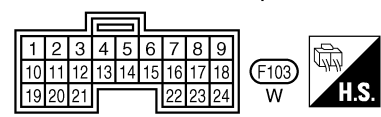
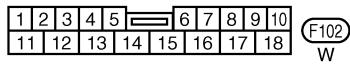
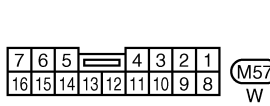
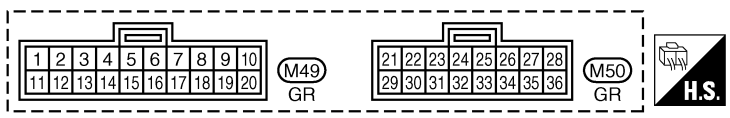
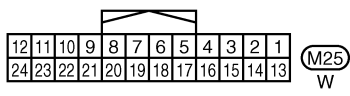
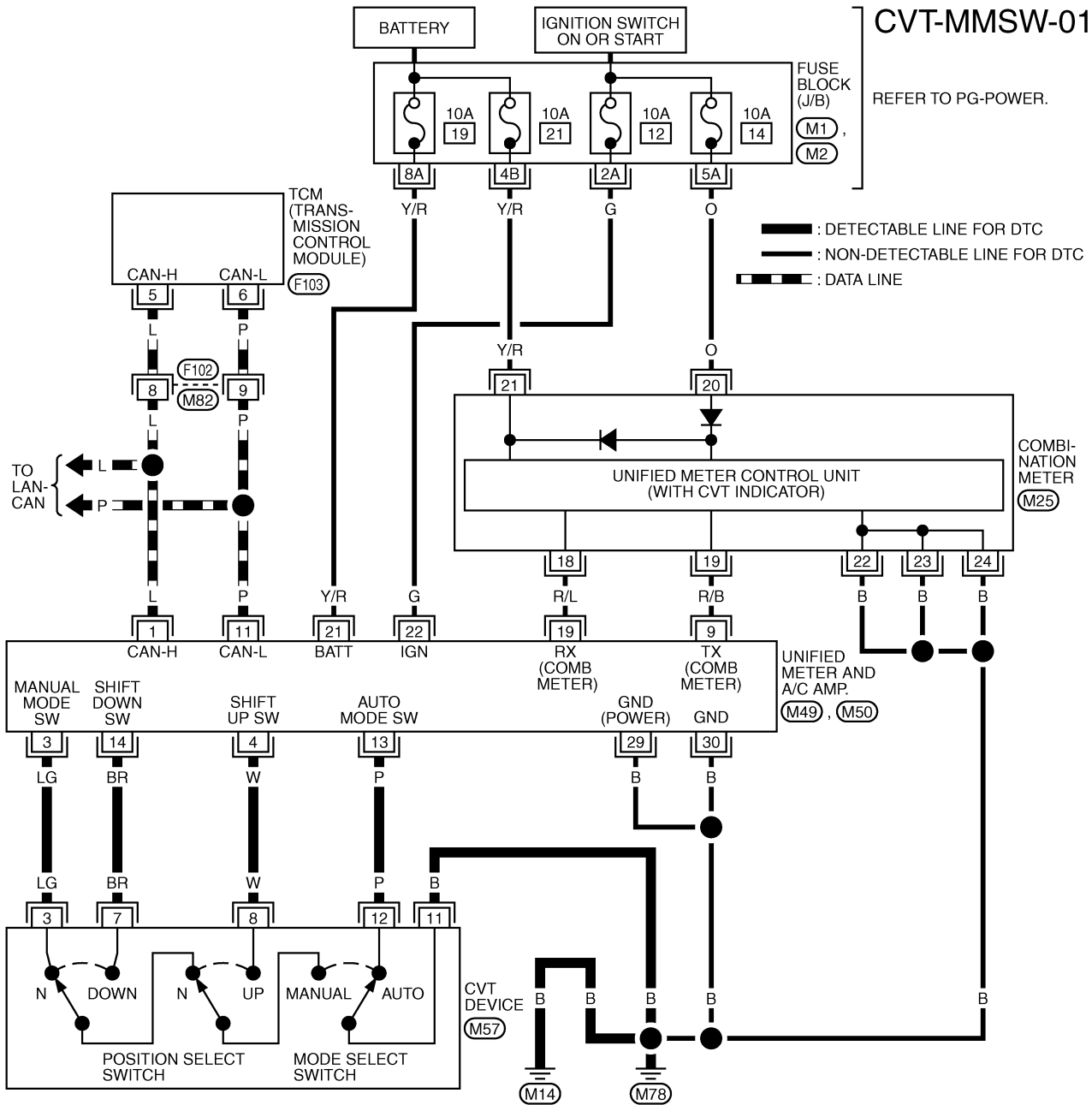

REFER TO THE FOLLOWING.
 (M1), (M2) - FUSE BLOCK-JUNCTION BOX (J/B)

TCWB0141E

DTC P0826 MANUAL MODE SWITCH CIRCUIT

TCM terminal data are reference values, measured between each terminal and ground.

Terminal	Wire color	Item	Condition	Data (Approx.)
5	L	CAN H	-	-
6	P	CAN L	-	-

A

B

CVT

D

E

F

G

H

I

J

K

L

M

DTC P0826 MANUAL MODE SWITCH CIRCUIT

Wiring Diagram — CVT — MMSW (RHD Models)

ECS00FZ1

CVT-MMSW-02

REFER TO PG-POWER.

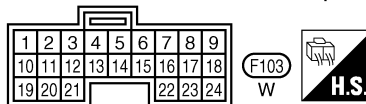
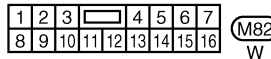
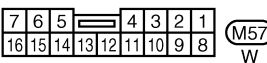
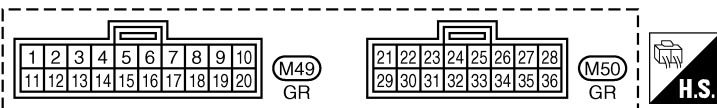
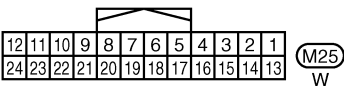
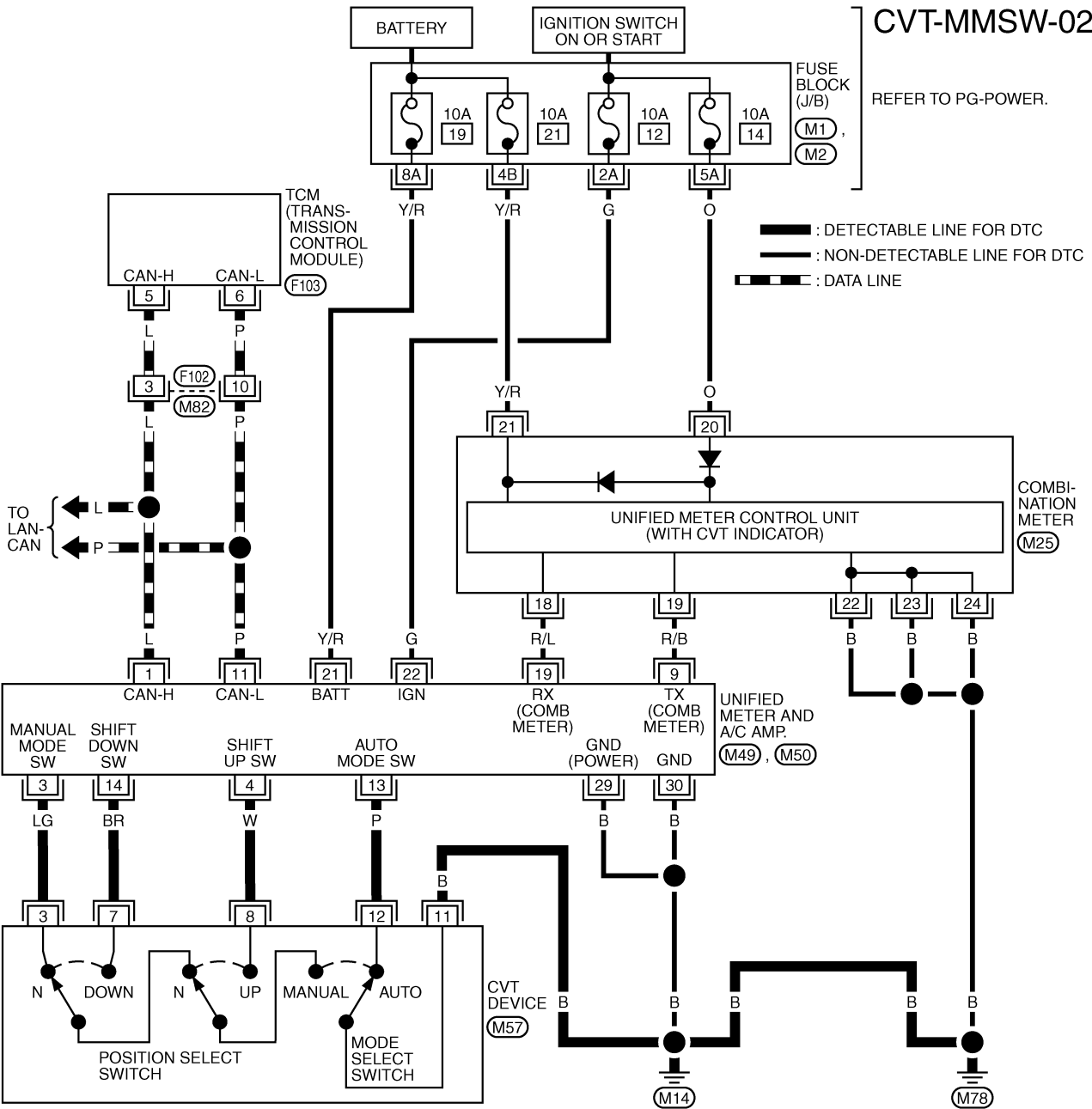

REFER TO THE FOLLOWING.
 (M1), (M2) - FUSE BLOCK-JUNCTION BOX (J/B)

TCWB0142E

DTC P0826 MANUAL MODE SWITCH CIRCUIT

TCM terminal data are reference values, measured between each terminal and ground.

Terminal	Wire color	Item	Condition	Data (Approx.)
5	L	CAN H	-	-
6	P	CAN L	-	-

Diagnostic Procedure

ECS00F9F

1. CHECK CAN COMMUNICATION LINE

Perform the self-diagnosis check. Refer to [CVT-58, "SELF-DIAGNOSTIC RESULT MODE"](#).

Is any malfunction of the "U1000 CAN COMM CIRCUIT" indicated?

- YES >> Check CAN communication line. Refer to [CVT-65, "DTC U1000 CAN COMMUNICATION LINE"](#).
 NO >> GO TO 2.

2. CHECK MANUAL MODE SWITCH CIRCUIT

With CONSULT-II

- Turn ignition switch ON. (Do not start engine.)
- Select "ECU INPUT SIGNALS" in "DATA MONITOR" mode for "TRANSMISSION" with CONSULT-II.
- Read out ON/OFF switching action of the "MMODE", "NON M-MODE", "UPLVR", "DOWNLVR".

DATA MONITOR			
MONITOR		NO DTC	
DOWNLVR		OFF	
UPLVR		OFF	
NON MMODE		ON	
MMODE		OFF	
△			
		RECORD	
MODE	BACK	LIGHT	COPY

SCIA4588E

Item name	Condition	Display value
MMODE	Manual shift gate position (neutral)	ON
	Other than the above	OFF
NON MMODE	Manual shift gate position (neutral, +side, -side)	OFF
	Other than the above	ON
UPLVR	Select lever: + side	ON
	Other than the above	OFF
DOWNLVR	Select lever: - side	ON
	Other than the above	OFF

Without CONSULT-II

Drive vehicle in the manual mode, and confirm that the actual gear position and the meter's indication of the position mutually coincide when the selector lever is shifted to the "+" (up) or "-" (down) side (1st ↔ 6th gear).

OK or NG

- OK >> GO TO 7.
 NG >> GO TO 3.

3. CHECK MANUAL MODE SWITCH

Check manual mode switch.

- Refer to [CVT-131, "Component Inspection"](#).

OK or NG

- OK >> GO TO 4.
 NG >> Repair or replace damaged parts.

DTC P0826 MANUAL MODE SWITCH CIRCUIT

4. CHECK SELF-DIAGNOSTIC RESULTS (UNIFIED METER AND A/C AMP)

Perform self-diagnosis check. Refer to [DI-29, "CONSULT-II Function \(METER A/C AMP\)"](#) .

Is any malfunction detected by self-diagnosis?

- YES >> Check the malfunctioning system.
- NO >> GO TO 5.

5. CHECK SELF-DIAGNOSTIC RESULTS (COMBINATION METER)

Perform self-diagnosis check. Refer to [DI-15, "Self-Diagnosis Mode of Combination Meter"](#) .

Is any malfunction detected by self-diagnosis?

- YES >> Check the malfunctioning system.
- NO >> GO TO 6.

6. CHECK MANUAL MODE SWITCH CIRCUIT

1. Turn ignition switch OFF.
2. Disconnect CVT device connector and unified meter and A/C amp connector.
3. Check continuity between CVT device harness connector terminal and unified meter and A/C amp harness connector terminal.

Item	Connector	Terminal	Continuity
CVT device harness connector	M57	3	Yes
Unified meter and A/C amp harness connector	M49	3	
CVT device harness connector	M57	7	Yes
Unified meter and A/C amp harness connector	M49	14	
CVT device harness connector	M57	8	Yes
Unified meter and A/C amp harness connector	M49	4	
CVT device harness connector	M57	12	Yes
Unified meter and A/C amp harness connector	M49	13	

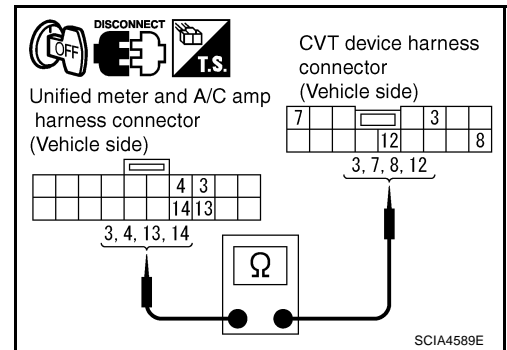

4. Check continuity between CVT device harness connector terminal and ground.

Item	Connector	Terminal	Continuity
CVT device harness connector	M57	11	Yes

5. If OK, check harness for short to ground and short to power.
6. Reinstall any part removed.

OK or NG

- OK >> GO TO 7.
- NG >> Repair open circuit or short to ground or short to power in harness or connectors.

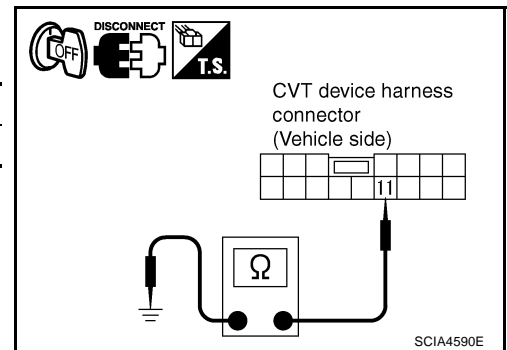

7. CHECK DTC

Perform "DTC Confirmation Procedure". Refer to [CVT-125, "DTC Confirmation Procedure"](#) .

OK or NG

- OK >> **INSPECTION END**
- NG >> GO TO 8.

DTC P0826 MANUAL MODE SWITCH CIRCUIT

8. CHECK TCM

1. Check TCM input/output signal. Refer to [CVT-50, "TCM Input/Output Signal Reference Values"](#) .
2. If NG, re-check TCM pin terminals for damage or loose connection with harness connector.

OK or NG

OK >> **INSPECTION END**

NG >> Repair or replace damaged parts.

Component Inspection MANUAL MODE SWITCH

ECS00F9G

CVT

Check continuity between CVT device harness connector terminals.

Item	Position	Connector	Terminal	Continuity
Manual mode select switch	Auto	M57	12 - 11	Yes
	Manual		3 - 11	
Manual mode position select switch	Up		8 - 11	
	Down		7 - 11	

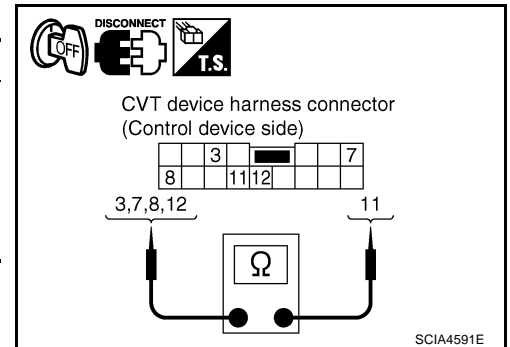

A
B
C
D
E
F
G
H
I
J
K
L
M

DTC P0840 TRANSMISSION FLUID PRESSURE SENSOR A CIRCUIT (SEC PRESSURE SENSOR)

DTC P0840 TRANSMISSION FLUID PRESSURE SENSOR A CIRCUIT (SEC PRESSURE SENSOR)

PFP:31936

Description

ECS00F9H

The transmission fluid pressure sensor A (secondary pressure sensor) detects secondary pressure of CVT and sends TCM the signal.

CONSULT-II Reference Value

ECS00F9I

Remarks: Specification data are reference values.

Item name	Condition	Display value (Approx.)
SEC HYDR SEN	"N" position idle	0.8 - 1.0V
SEC PRESS		0.5 - 0.9 MPa

On Board Diagnosis Logic

ECS00F9J

- This is an OBD-II self-diagnostic item.
- Diagnostic trouble code "P0840 TR PRS SENS/A CIRC" with CONSULT-II is detected when TCM detects an improper voltage drop when it receives the sensor signal.

Possible Cause

ECS00F9K

- Transmission fluid pressure sensor A (Secondary pressure sensor)
- Harness or connectors
(Switch circuit is open or shorted.)

DTC Confirmation Procedure

ECS00F9L

CAUTION:

- Always drive vehicle at a safe speed.
- Be careful not to rev engine into the red zone on the tachometer.

NOTE:

If "DTC Confirmation Procedure" has been previously performed, always turn ignition switch OFF and wait at least 5 seconds before performing the next test.

After the repair, perform the following procedure to confirm the malfunction is eliminated.

WITH CONSULT-II

1. Turn ignition switch ON and select "DATA MONITOR" mode for "TRANSMISSION" with CONSULT-II.
2. Make sure that output voltage of line temperature sensor is within the range below.
ATF TEMP SEN: 1.0 - 2.0V
If out of range, drive the vehicle to decrease the voltage (warm up the fluid) or stop engine to increase the voltage (cool down the fluid)
3. Start engine and wait for at least 5 consecutive seconds.
4. If DTC is detected, go to [CVT-134, "Diagnostic Procedure"](#).

SELECT SYSTEM
IPDM E/R
BCM
AUTO DRIVE POS
AIR PRESSURE MONITOR
TRANSMISSION
METER A/C AMP

SCIA4825E

WITH GST

Follow the procedure "WITH CONSULT-II".

DTC P0840 TRANSMISSION FLUID PRESSURE SENSOR A CIRCUIT (SEC PRESSURE SENSOR)

Wiring Diagram — CVT — SECPS

ECS00F9M

CVT-SECPS-01



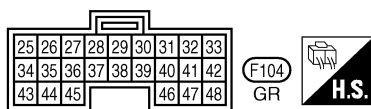
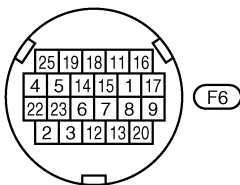
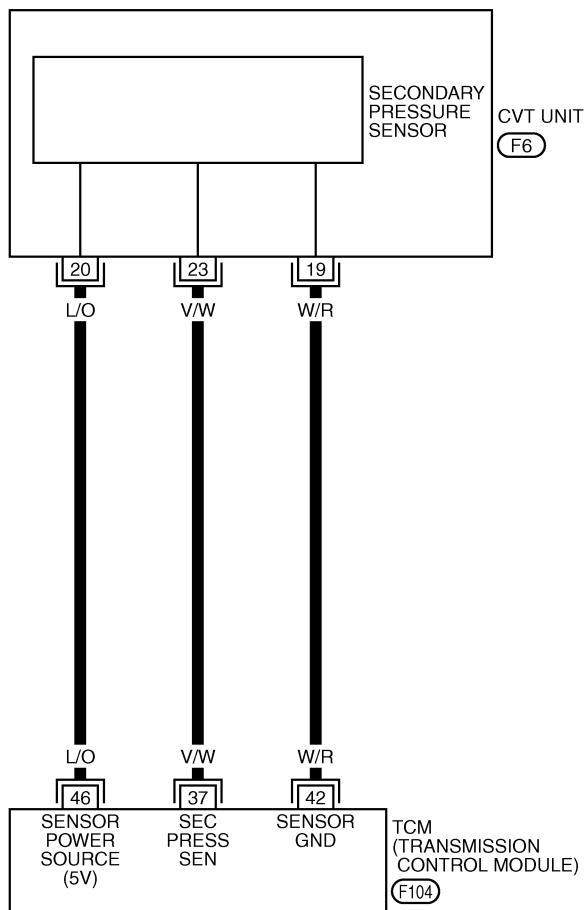

: DETECTABLE LINE FOR DTC
 : NON-DETECTABLE LINE FOR DTC



TCWA0253E

DTC P0840 TRANSMISSION FLUID PRESSURE SENSOR A CIRCUIT (SEC PRESSURE SENSOR)

TCM terminal data are reference values, measured between each terminal and ground.

Terminal	Wire color	Item	Condition	Data (Approx.)
37	V/W	Transmission fluid pressure sensor A (Secondary pressure sensor)	 and  "N" position idle	0.8V
42	W/R	Sensor ground	Always	0V
46	L/O	Sensor power	 —	4.5 - 5.5V
			 —	0V

Diagnostic Procedure

ECS00F9N

1. CHECK INPUT SIGNAL

Ⓜ With CONSULT-II

- Start engine.
- Select "ECU INPUT SIGNALS" in "DATA MONITOR" mode for "TRANSMISSION" with CONSULT-II.
- Start vehicle and read out the value of "SEC HYDR SEN".

Item name	Condition	Display value (Approx.)
SEC HYDR SEN	"N" position idle	0.8 - 1.0V

DATA MONITOR	
MONITOR	NO DTC
VSP SENSOR	1 km / h
ESTM VSP SIG	0 km / h
PRI SPEED SEN	32 rpm
ENG SPEED SIG	0 rpm
SEC HYDR SEN	0.47 V
▼	
RECORD	
MODE	BACK
LIGHT	COPY

SCIA2279E

⊗ Without CONSULT-II

- Start engine.
- Check voltage between TCM connector terminal and ground.

Name	Connector	Terminal	Condition	Voltage (Approx.)
Transmission fluid pressure sensor A (Secondary pressure sensor)	F104	37 - Ground	"N" position idle	0.8V

OK or NG

- OK >> GO TO 5.
 NG >> GO TO 2.

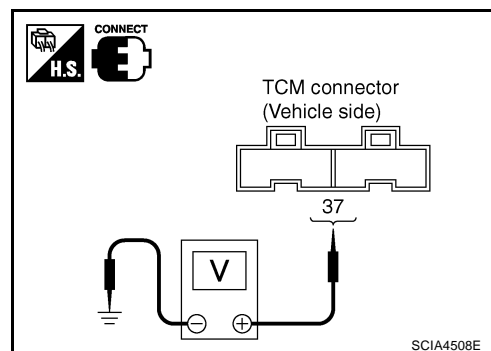

DTC P0840 TRANSMISSION FLUID PRESSURE SENSOR A CIRCUIT (SEC PRESSURE SENSOR)

2. CHECK SENSOR POWER AND SENSOR GROUND

1. Turn ignition switch ON. (Do not start engine.)
2. Check voltage between TCM connector terminals.

Item	Connector	Terminal	Data (Approx.)
TCM connector	F104	46 - 42	4.5 - 5.5V

OK or NG

- OK >> GO TO 4.
 NG >> GO TO 3.

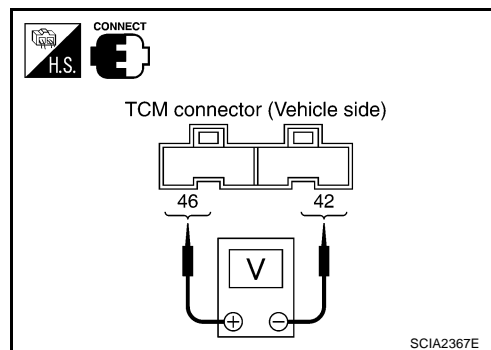

3. CHECK HARNESS BETWEEN TCM AND CVT UNIT HARNESS CONNECTOR (SENSOR POWER AND SENSOR GROUND)

1. Turn ignition switch OFF.
2. Disconnect TCM connector and CVT unit harness connector.
3. Check continuity between TCM connector terminal and CVT unit harness connector terminal.

Item	Connector	Terminal	Continuity
TCM	F104	42	Yes
CVT unit harness connector	F6	19	
TCM	F104	46	Yes
CVT unit harness connector	F6	20	

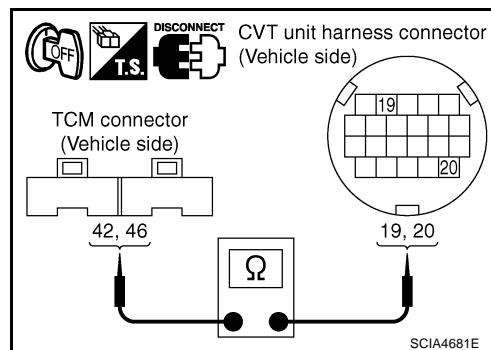

4. If OK, check harness for short to ground and short to power.
5. Reinstall any part removed.

OK or NG

- OK >> Replace TCM. Refer to [CVT-8, "Precautions for TCM and CVT Assembly Replacement"](#) .
 NG >> Repair open circuit or short to ground or short to power in harness or connectors.

4. CHECK TRANSMISSION FLUID PRESSURE SENSOR A (SECONDARY PRESSURE SENSOR) CIRCUIT

1. Turn ignition switch OFF.
2. Disconnect TCM connector and CVT unit harness connector.
3. Check continuity between TCM connector terminal and CVT unit harness connector terminal.

Item	Connector	Terminal	Continuity
TCM	F104	37	Yes
CVT unit harness connector	F6	23	

4. If OK, check harness for short to ground and short to power.
5. Reinstall any part removed.

OK or NG

- OK >> GO TO 5.
 NG >> Repair open circuit or short to ground or short to power in harness or connectors.

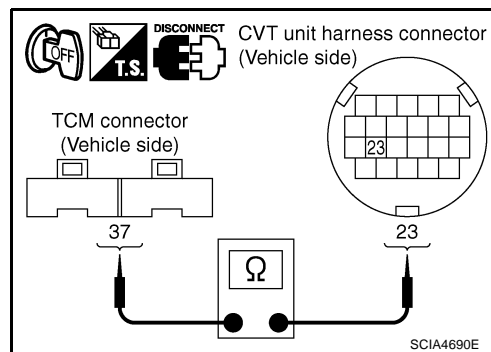

DTC P0840 TRANSMISSION FLUID PRESSURE SENSOR A CIRCUIT (SEC PRESSURE SENSOR)

5. CHECK DTC

Perform "DTC Confirmation Procedure". Refer to [CVT-132, "DTC Confirmation Procedure"](#) .

OK or NG

OK >> **INSPECTION END**
NG >> GO TO 6.

6. CHECK TCM

1. Check TCM input/output signal. Refer to [CVT-50, "TCM Input/Output Signal Reference Values"](#) .
2. If NG, re-check TCM pin terminals for damage or loose connection with harness connector.

OK or NG

OK >> Replace the transaxle assembly. Refer to [CVT-226, "Removal and Installation"](#) .
NG >> Repair or replace damaged parts.

DTC P0841 PRESSURE SENSOR FUNCTION

DTC P0841 PRESSURE SENSOR FUNCTION

PFP:31936

Description

ECS00F90

Using the engine load (throttle position), the primary pulley revolution speed, and the secondary pulley revolution speed as input signal, TCM changes the operating pressure of the primary pulley and the secondary pulley and changes the groove width of the pulley to control the gear ratio.

CONSULT-II Reference Value

ECS00F9P

Remarks: Specification data are reference values.

Item name	Condition	Display value (Approx.)
PRI HYDR SEN	"N" position idle	0.7 - 3.5V
SEC HYDR SEN		0.8 - 1.0V

On Board Diagnosis Logic

ECS00F9Q

- This is not an OBD-II self-diagnostic item.
- Diagnostic trouble code "P0841 PRESS SEN/FNCTN" with CONSULT-II is detected when correlation between the values of the secondary pressure sensor and the primary pressure sensor is out of specification.

Possible Cause

ECS00F9R

- Transmission fluid pressure sensor A (Secondary pressure sensor)
- Transmission fluid pressure sensor B (Primary pressure sensor)
- Harness or connectors
(Sensor circuit is open or shorted.)

DTC Confirmation Procedure

ECS00F9S

CAUTION:

- Always drive vehicle at a safe speed.
- Be careful not to rev engine into the red zone on the tachometer.

NOTE:

If "DTC Confirmation Procedure" has been previously performed, always turn ignition switch OFF and wait at least 5 seconds before performing the next test.

After the repair, perform the following procedure to confirm the malfunction is eliminated.

Ⓟ WITH CONSULT-II

1. Turn ignition switch ON and select "DATA MONITOR" mode for "TRANSMISSION" with CONSULT-II.
2. Start engine and maintain the following conditions for at least 12 consecutive seconds.
VHCL SPEED: 40 km/h (25 MPH) More than
Selector lever: "D" position
3. If DTC is detected, go to [CVT-138, "Diagnostic Procedure"](#).

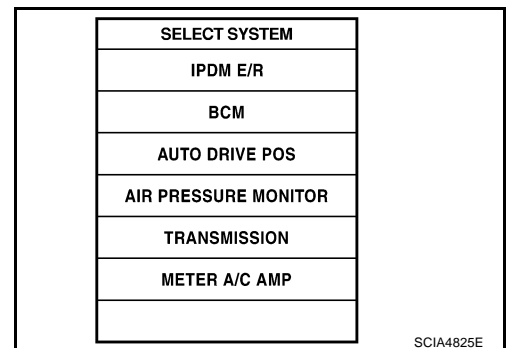

DTC P0841 PRESSURE SENSOR FUNCTION

ECS00F9T

Diagnostic Procedure

1. CHECK CAN COMMUNICATION LINE

Perform the self-diagnosis. Refer to [CVT-58, "SELF-DIAGNOSTIC RESULT MODE"](#) .

Is any malfunction of the "U1000 CAN COMM CIRCUIT" indicated?

- YES >> Check CAN communication line. Refer to [CVT-65, "DTC U1000 CAN COMMUNICATION LINE"](#) .
- NO >> GO TO 2.

2. CHECK INPUT SIGNALS

With CONSULT-II

1. Start engine.
2. Select "ECU INPUT SIGNALS" in "DATA MONITOR" mode for "TRANSMISSION" with CONSULT-II.
3. Start vehicle and read out the value of "SEC HYDR SEN" and "PRI HYDR SEN".

Item name	Condition	Display value (Approx.)
PRI HYDR SEN	"N" position idle	0.7 - 3.5V
SEC HYDR SEN		0.8 - 1.0V

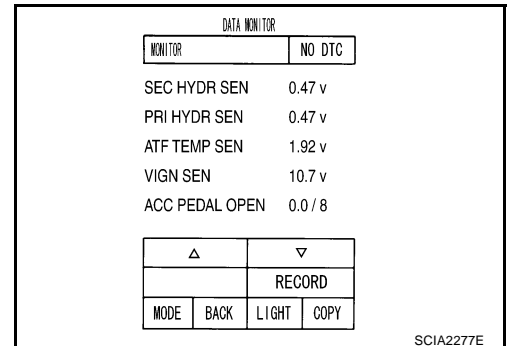

Without CONSULT-II

1. Start engine.
2. Check voltage between TCM connector terminals and ground.

Name	Connector	Terminal	Condition	Voltage (Approx.)
Transmission fluid pressure sensor B (Primary pressure sensor)	F104	41 - Ground	"N" position idle	0.7 - 3.5V
Transmission fluid pressure sensor A (Secondary pressure sensor)		37 - Ground		0.8V

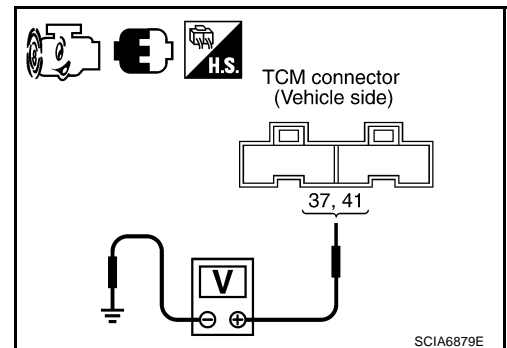

OK or NG

- OK >> GO TO 6.
- NG >> GO TO 3.

3. CHECK LINE PRESSURE

Perform line pressure test. Refer to [CVT-39, "LINE PRESSURE TEST"](#) .

OK or NG

- OK >> GO TO 4.
- NG >> Repair or replace damaged parts. Refer to [CVT-40, "Judgement of Line Pressure Test"](#) .

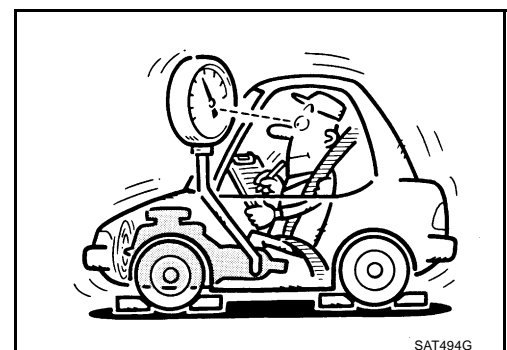

DTC P0841 PRESSURE SENSOR FUNCTION

4. CHECK TRANSMISSION FLUID PRESSURE SENSOR A (SECONDARY PRESSURE SENSOR) SYSTEM AND TRANSMISSION FLUID PRESSURE SENSOR B (PRIMARY PRESSURE SENSOR) SYSTEM

Check secondary pressure sensor system and primary pressure sensor system. Refer to [CVT-132, "DTC P0840 TRANSMISSION FLUID PRESSURE SENSOR A CIRCUIT \(SEC PRESSURE SENSOR\)"](#), [CVT-140, "DTC P0845 TRANSMISSION FLUID PRESSURE SENSOR B CIRCUIT \(PRI PRESSURE SENSOR\)"](#).

OK or NG

- OK >> GO TO 5.
- NG >> Repair or replace damaged parts.

5. DETECT MALFUNCTIONING ITEM

Check the following:

- Line pressure solenoid valve. Refer to [CVT-113, "Component Inspection"](#).
- Secondary pressure solenoid valve. Refer to [CVT-124, "Component Inspection"](#).
- Step motor. Refer to [CVT-172, "Component Inspection"](#).

OK or NG6

- OK >> GO TO 6.
- NG >> Repair or replace damaged parts.

6. CHECK DTC

Perform "DTC Confirmation Procedure". Refer to [CVT-137, "DTC Confirmation Procedure"](#).

OK or NG

- OK >> **INSPECTION END**
- NG >> Replace TCM or transaxle assembly. Refer to [CVT-226, "Removal and Installation"](#).

DTC P0845 TRANSMISSION FLUID PRESSURE SENSOR B CIRCUIT (PRI PRESSURE SENSOR)

DTC P0845 TRANSMISSION FLUID PRESSURE SENSOR B CIRCUIT (PRI PRESSURE SENSOR)

PFP:31936

Description

ECS00F9U

The primary pressure sensor detects primary pressure of CVT and sends TCM the signal.

CONSULT-II Reference Value

ECS00F9V

Remarks: Specification data are reference values.

Item name	Condition	Display value (Approx.)
PRI HYDR SEN	"N" position idle	0.7 - 3.5V

On Board Diagnosis Logic

ECS00F9W

- This is an OBD-II self-diagnostic item.
- Diagnostic trouble code "P0845 TR PRS SENS/B CIRC" with CONSULT-II is detected under the following conditions.
 - When TCM detects an improper voltage drop when it receives the sensor signal.
 - When TCM compares target value with monitor value and detects an irregularity.

Possible Cause

ECS00F9X

- Transmission fluid pressure sensor B (Primary pressure sensor)
- Harness or connectors
(Sensor circuit is open or shorted.)

DTC Confirmation Procedure

ECS00F9Y

CAUTION:

- Always drive vehicle at a safe speed.
- Be careful not to rev engine into the red zone on the tachometer.

NOTE:

If "DTC Confirmation Procedure" has been previously performed, always turn ignition switch OFF and wait at least 5 seconds before performing the next test.

After the repair, perform the following procedure to confirm the malfunction is eliminated.

WITH CONSULT-II

1. Turn ignition switch ON and select "DATA MONITOR" mode for "TRANSMISSION" with CONSULT-II.
2. Make sure that output voltage of line temperature sensor is within the range below.
ATF TEMP SEN: 1.0 - 2.0V
If out of range, drive the vehicle to decrease the voltage (warm up the fluid) or stop engine to increase the voltage (cool down the fluid)
3. Start engine and wait for at least 5 consecutive seconds.
4. If DTC is detected, go to [CVT-142, "Diagnostic Procedure"](#).

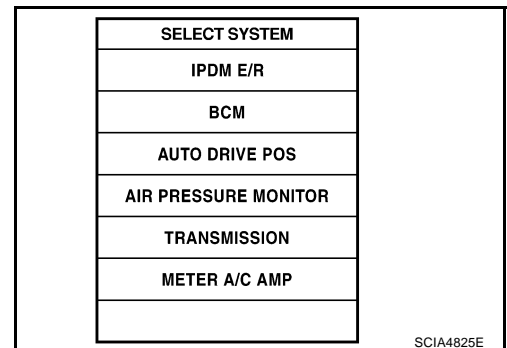

WITH GST

Follow the procedure "WITH CONSULT-II".

DTC P0845 TRANSMISSION FLUID PRESSURE SENSOR B CIRCUIT (PRI PRESSURE SENSOR)

Wiring Diagram — CVT — PRIPS

ECS00F9Z

CVT-PRIPS-01



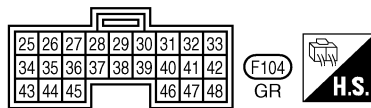
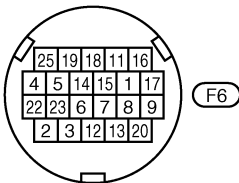
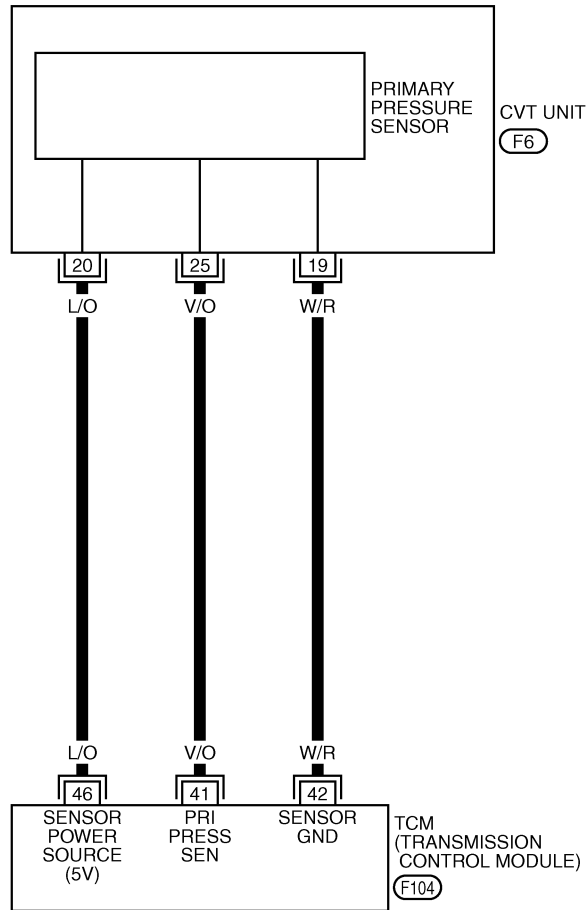

— : DETECTABLE LINE FOR DTC
— : NON-DETECTABLE LINE FOR DTC



TCWA0255E

DTC P0845 TRANSMISSION FLUID PRESSURE SENSOR B CIRCUIT (PRI PRESSURE SENSOR)

TCM terminal data are reference values, measured between each terminal and ground.

Terminal	Wire color	Item	Condition		Data (Approx.)
41	V/O	Transmission fluid pressure sensor B (Primary pressure sensor)		and 	"N" position idle 0.7 - 3.5V
42	W/R	Sensor ground	Always		0V
46	L/O	Sensor power		—	4.5 - 5.5V
				—	0V

Diagnostic Procedure

ECS00FA0

1. CHECK INPUT SIGNAL

With CONSULT-II

- Start engine.
- Select "ECU INPUT SIGNALS" in "DATA MONITOR" mode for "TRANSMISSION" with CONSULT-II.
- Start vehicle and read out the value of "PRI HYDR SEN".

Item name	Condition	Display value (Approx.)
PRI HYDR SEN	"N" position idle	0.7 - 3.5V

DATA MONITOR	
MONITOR	NO DTC
SEC HYDR SEN	0.47 v
PRI HYDR SEN	0.47 v
ATF TEMP SEN	1.92 v
VIGN SEN	10.7 v
ACC PEDAL OPEN	0.0 / 8

△	▽
RECORD	
MODE	BACK
LIGHT	COPY

SCIA2277E

Without CONSULT-II

- Start engine.
- Check voltage between TCM connector terminal and ground.

Name	Connector	Terminal	Condition	Voltage (Approx.)
Transmission fluid pressure sensor B (Primary pressure sensor)	F104	41 - Ground	"N" position idle	0.7 - 3.5V

OK or NG

- OK >> GO TO 5.
 NG >> GO TO 2.

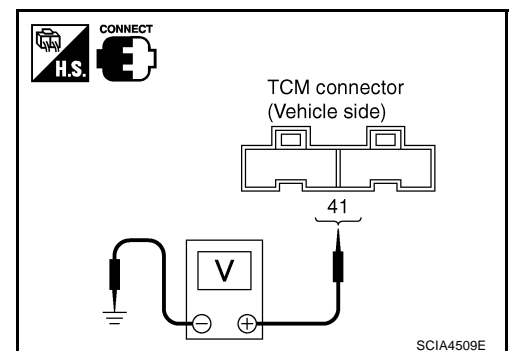

DTC P0845 TRANSMISSION FLUID PRESSURE SENSOR B CIRCUIT (PRI PRESSURE SENSOR)

2. CHECK SENSOR POWER AND SENSOR GROUND

1. Turn ignition switch ON. (Do not start engine.)
2. Check voltage between TCM connector terminals.

Item	Connector	Terminal	Data (Approx.)
TCM connector	F104	46 - 42	4.5 - 5.5V

OK or NG

- OK >> GO TO 4.
 NG >> GO TO 3.

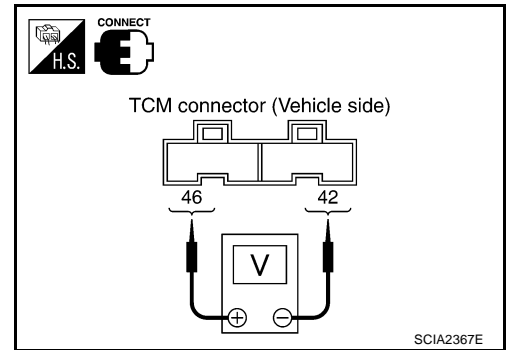

3. CHECK HARNESS BETWEEN TCM AND CVT UNIT HARNESS CONNECTOR (SENSOR POWER AND SENSOR GROUND)

1. Turn ignition switch OFF.
2. Disconnect TCM connector and CVT unit harness connector.
3. Check continuity between TCM connector terminal and CVT unit harness connector terminal.

Item	Connector	Terminal	Continuity
TCM	F104	42	Yes
CVT unit harness connector	F6	19	
TCM	F104	46	Yes
CVT unit harness connector	F6	20	

4. If OK, check harness for short to ground and short to power.
5. Reinstall any part removed.

OK or NG

- OK >> Replace TCM. Refer to [CVT-8, "Precautions for TCM and CVT Assembly Replacement"](#) .
 NG >> Repair open circuit or short to ground or short to power in harness or connectors.

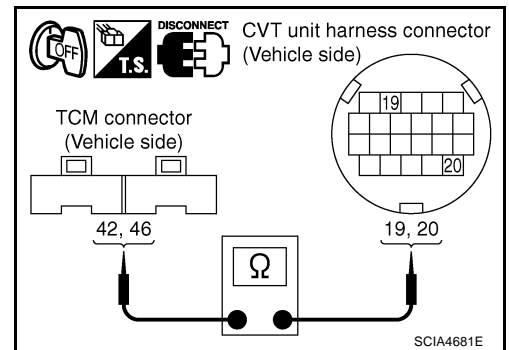

4. CHECK TRANSMISSION FLUID PRESSURE SENSOR B (PRIMARY PRESSURE SENSOR) CIRCUIT

1. Turn ignition switch OFF.
2. Disconnect TCM connector.
3. Check continuity between TCM connector terminal and CVT unit harness connector terminal.

Item	Connector	Terminal	Continuity
TCM	F104	41	Yes
CVT unit harness connector	F6	25	

4. If OK, check harness for short to ground and short to power.
5. Reinstall any part removed.

OK or NG

- OK >> GO TO 5.
 NG >> Repair open circuit or short to ground or short to power in harness or connectors.

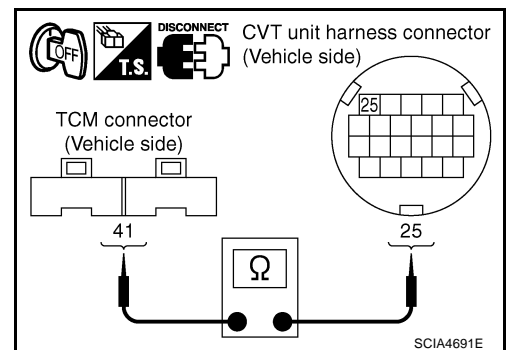

DTC P0845 TRANSMISSION FLUID PRESSURE SENSOR B CIRCUIT (PRI PRESSURE SENSOR)

5. CHECK DTC

Perform "DTC Confirmation Procedure". Refer to [CVT-140, "DTC Confirmation Procedure"](#) .

OK or NG

OK >> **INSPECTION END**
NG >> GO TO 6.

6. CHECK TCM

1. Check TCM input/output signal. Refer to [CVT-50, "TCM Input/Output Signal Reference Values"](#) .
2. If NG, re-check TCM pin terminals for damage or loose connection with harness connector.

OK or NG

OK >> Replace the transaxle assembly. Refer to [CVT-226, "Removal and Installation"](#) .
NG >> Repair or replace damaged parts.

DTC P0868 SECONDARY PRESSURE DOWN

DTC P0868 SECONDARY PRESSURE DOWN

PFP:31941

Description

ECS00FA1

The pressure control solenoid valve B (secondary pressure solenoid valve) regulates the secondary pressure to suit the driving condition in response to a signal sent from the TCM.

CONSULT-II Reference Value

ECS00FA2

Remarks: Specification data are reference values.

Item name	Condition	Display value (Approx.)
SEC PRESS	"N" position idle	0.5 - 0.9 MPa

On Board Diagnosis Logic

ECS00FA3

- This is not an OBD-II self-diagnostic item.
- Diagnostic trouble code "P0868 SEC/PRESS DOWN" with CONSULT-II is detected when secondary fluid pressure is too low compared with the commanded value while driving.

Possible Cause

ECS00FA4

- Harness or connectors (Solenoid circuit is open or shorted.)
- Pressure control solenoid valve B (Secondary pressure solenoid valve) system
- Transmission fluid pressure sensor A (Secondary pressure sensor)
- Line pressure control system

DTC Confirmation Procedure

ECS00FA5

CAUTION:

- Always drive vehicle at a safe speed.
- Be careful not to rev engine into the red zone on the tachometer.

NOTE:

If "DTC Confirmation Procedure" has been previously performed, always turn ignition switch OFF and wait at least 5 seconds before performing the next test.

After the repair, perform the following procedure to confirm the malfunction is eliminated.

ⓑ WITH CONSULT-II

1. Turn ignition switch ON and select "DATA MONITOR" mode for "TRANSMISSION" with CONSULT-II.
2. Make sure that output voltage of CVT fluid temperature sensor is within the range below.
FLUID TEMP SEN: 1.0 - 2.0V
If out of range, drive the vehicle to decrease the voltage (warm up the fluid) or stop engine to increase the voltage (cool down the fluid)
3. Start engine and maintain the following conditions for at least 10 consecutive seconds.
VEHICLE SPEED (accelerate slowly): 0 → 50 km/h (31 MPH)
ACC PEDAL OPEN: 0.5/8 - 1.0/8
Selector lever: "D" position
4. If DTC is detected, go to [CVT-146, "Diagnostic Procedure"](#).

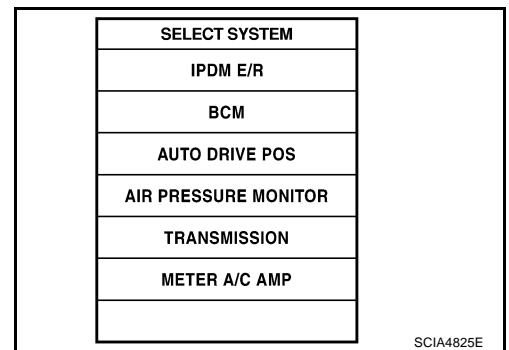

DTC P0868 SECONDARY PRESSURE DOWN

EC500FA6

Diagnostic Procedure

1. CHECK INPUT SIGNAL

With CONSULT-II

1. Start engine.
2. Select "MAIN SIGNALS" in "DATA MONITOR" mode for "TRANSMISSION" with CONSULT-II.
3. Start vehicle and read out the value of "SEC PRESS".

Item name	Condition	Display value (Approx.)
SEC PRESS	"N" position idle	0.5 - 0.9 MPa

OK or NG

- OK >> GO TO 5.
NG >> GO TO 2.

DATA MONITOR	
MONITOR	NO. DTC
GEAR RATIO	2.37
ACC PEDAL OPEN	0.0 / 8
VENG TRQ	217.6 Nm
SEC PRESS	0.000 MPa
PRI PRESS	0.000 MPa

△		▽	
RECORD			
MODE	BACK	LIGHT	COPY

SCIA2366E

2. CHECK LINE PRESSURE

Perform line pressure test. Refer to [CVT-39, "LINE PRESSURE TEST"](#).

OK or NG

- OK >> GO TO 3.
NG >> Repair or replace damaged parts. Refer to [CVT-40, "Judgement of Line Pressure Test"](#).

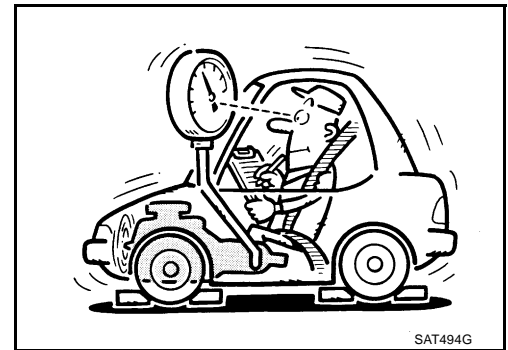

3. DETECT MALFUNCTIONING ITEM

Check the following:

- Pressure control solenoid valve B (Secondary pressure solenoid valve). Refer to [CVT-124, "Component Inspection"](#).
- Pressure control solenoid valve A (Line pressure solenoid valve). Refer to [CVT-113, "Component Inspection"](#).

OK or NG

- OK >> GO TO 4.
NG >> Repair or replace damaged parts.

4. CHECK TRANSMISSION FLUID PRESSURE SENSOR A (SECONDARY PRESSURE SENSOR) SYSTEM

Check transmission fluid pressure sensor A (secondary pressure sensor) system. Refer to [CVT-132, "DTC P0840 TRANSMISSION FLUID PRESSURE SENSOR A CIRCUIT \(SEC PRESSURE SENSOR\)"](#).

OK or NG

- OK >> GO TO 5.
NG >> Repair or replace damaged parts.

DTC P0868 SECONDARY PRESSURE DOWN

5. DETECT MALFUNCTIONING ITEM

Check the following:

- Power supply and ground circuit for TCM. Refer to [CVT-149, "Wiring Diagram — CVT — POWER \(LHD Models\)"](#) , [CVT-151, "Wiring Diagram — CVT — POWER \(RHD Models\)"](#) .
- The TCM pin terminals for damage or loose connection with harness connector.

OK or NG

- OK >> GO TO 6.
- NG >> Repair or replace damaged parts.

6. CHECK DTC

Perform "DTC Confirmation Procedure". Refer to [CVT-145, "DTC Confirmation Procedure"](#) .

OK or NG

- OK >> **INSPECTION END**
- NG >> Replace the transaxle assembly. Refer to [CVT-226, "Removal and Installation"](#) .

A
B
CVT
D
E
F
G
H
I
J
K
L
M

DTC P1701 TRANSMISSION CONTROL MODULE (POWER SUPPLY)

DTC P1701 TRANSMISSION CONTROL MODULE (POWER SUPPLY)

PFP:31036

Description

ECS00FA7

When the power supply to the TCM is cut OFF, for example because the battery is removed, and the self-diagnosis memory function stops, malfunction is detected.

NOTE:

Since "P1701 TCM-POWER SUPPLY" will be indicated when replacing TCM, perform diagnosis after erasing "SELF-DIAG RESULTS"

On Board Diagnosis Logic

ECS00FA8

- This is not an OBD-II self-diagnostic item.
- Diagnostic trouble code "P1701 TCM-POWER SUPPLY" with CONSULT-II is detected when TCM does not receive the voltage signal from the battery power supply.
- This is not a malfunction message. (Whenever shutting OFF a power supply to the TCM, this message appears on the screen.)

Possible Cause

ECS00FA9

Harness or connectors
(Battery or ignition switch and TCM circuit is open or shorted.)

DTC Confirmation Procedure

ECS00FAA

NOTE:

If "DTC Confirmation Procedure" has been previously conducted, always turn ignition switch OFF and wait at least 10 seconds before conducting the next test.

After the repair, perform the following procedure to confirm the malfunction is eliminated.

④ WITH CONSULT-II

1. Turn ignition switch ON. (Do not start engine.)
2. Turn ignition switch ON and select "DATA MONITOR" mode for "TRANSMISSION" with CONSULT-II.
3. Wait for at least 2 consecutive seconds.
4. If DTC is detected, go to [CVT-152, "Diagnostic Procedure"](#).

SELECT SYSTEM
IPDM E/R
BCM
AUTO DRIVE POS
AIR PRESSURE MONITOR
TRANSMISSION
METER A/C AMP

SCIA4825E

DTC P1701 TRANSMISSION CONTROL MODULE (POWER SUPPLY)

Wiring Diagram — CVT — POWER (LHD Models)

EC500FAB

CVT-POWER-01

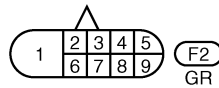
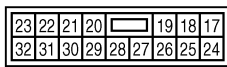
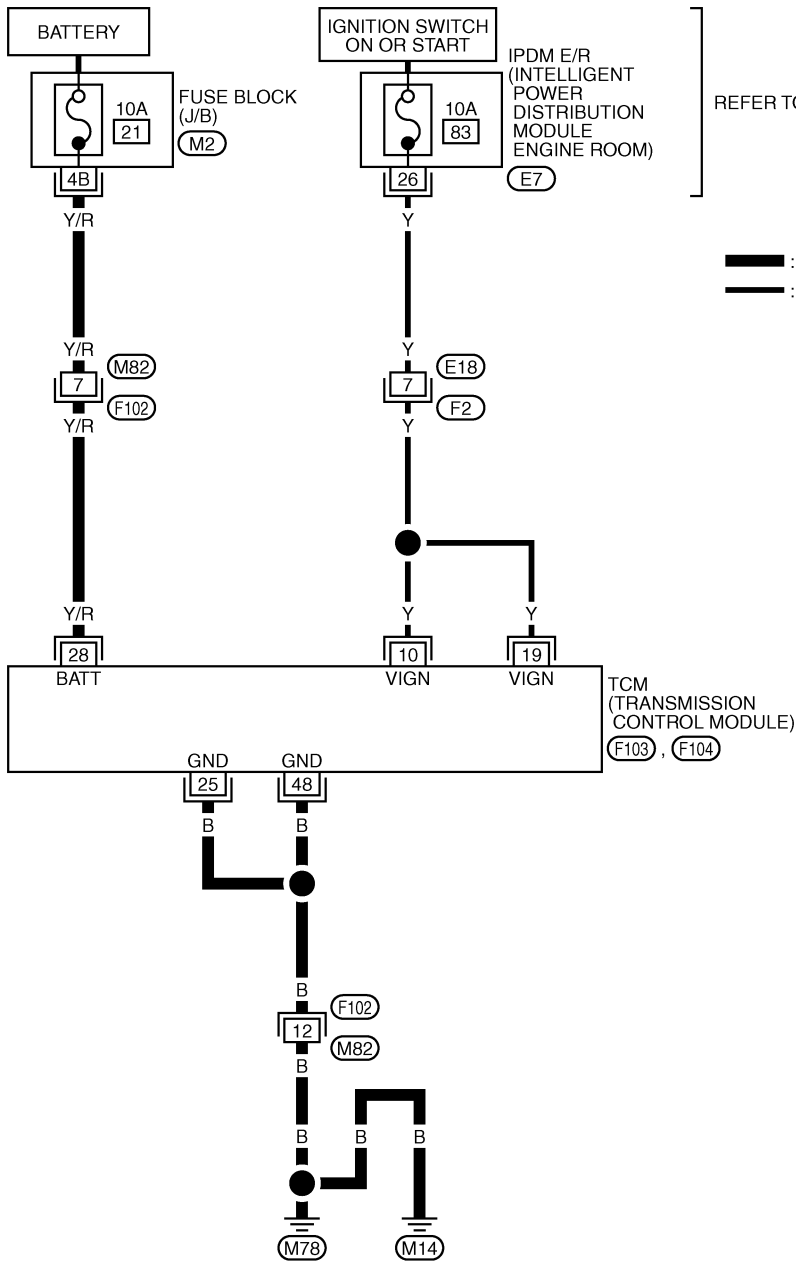

REFER TO THE FOLLOWING.



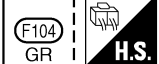
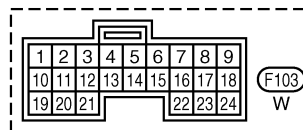
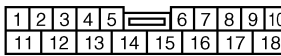

(M2) - FUSE BLOCK-JUNCTION BOX (J/B)



TCWB0143E

DTC P1701 TRANSMISSION CONTROL MODULE (POWER SUPPLY)

TCM terminals data are reference values, measured between each terminal and ground.

Terminal	Wire color	Item	Condition		Data (Approx.)
10	Y	Power supply		-	Battery voltage
				-	0V
19	Y	Power supply		-	Battery voltage
				-	0V
25	B	Ground	Always		0V
28	Y/R	Power supply (memory back-up)	Always		Battery voltage
48	B	Ground	Always		0V

DTC P1701 TRANSMISSION CONTROL MODULE (POWER SUPPLY)

Wiring Diagram — CVT — POWER (RHD Models)

ECS00G4H

CVT-POWER-02

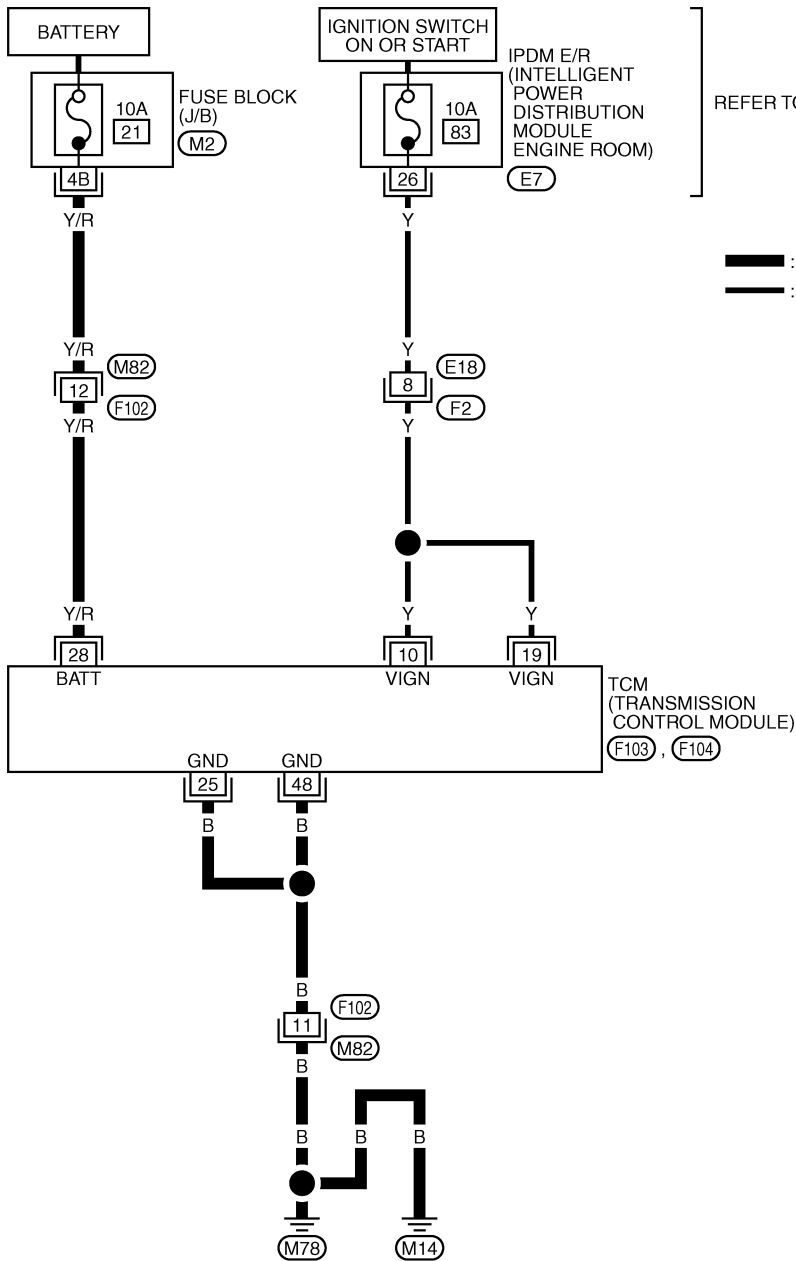

REFER TO PG-POWER.

: DETECTABLE LINE FOR DTC
 : NON-DETECTABLE LINE FOR DTC

A
B
CVT
D
E
F
G
H
I
J
K
L
M

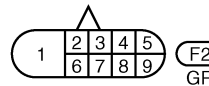
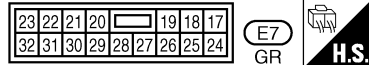
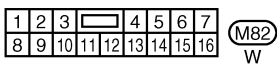



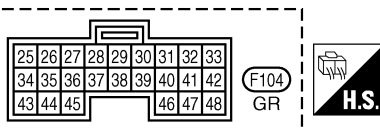
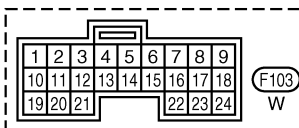

REFER TO THE FOLLOWING.
 (M2) -FUSE BLOCK-JUNCTION BOX (J/B)



TCWB0144E

DTC P1701 TRANSMISSION CONTROL MODULE (POWER SUPPLY)

TCM terminals data are reference values, measured between each terminal and ground.

Terminal	Wire color	Item	Condition		Data (Approx.)
10	Y	Power supply		-	Battery voltage
				-	0V
19	Y	Power supply		-	Battery voltage
				-	0V
25	B	Ground	Always		0V
28	Y/R	Power supply (memory back-up)	Always		Battery voltage
48	B	Ground	Always		0V

Diagnostic Procedure

ECS00FAC

1. CHECK DTC

- Turn ignition switch ON. (Do not start engine.)
- Select "SELF-DIAG RESULTS" mode for "TRANSMISSION" with CONSULT-II.
- Erase self-diagnostic results. Refer to [CVT-60, "How to Erase Self-diagnostic Results"](#).
- Turn ignition switch OFF, and wait for 5 seconds or more.
- Start engine.
- Confirm self-diagnostic results again. Refer to [CVT-58, "SELF-DIAGNOSTIC RESULT MODE"](#).

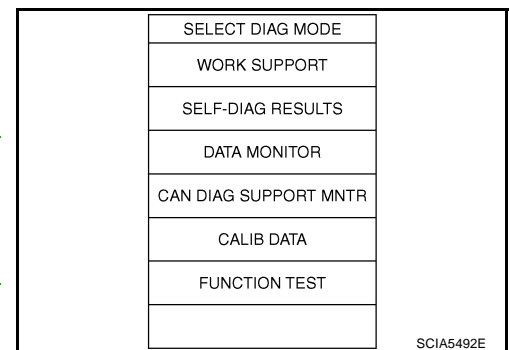

Is the "P1701 TCM-POWER SUPPLY" displayed?

YES >> GO TO 2.

NO >> **INSPECTION END**

2. CHECK TCM POWER SOURCE, STEP 1

- Turn ignition switch OFF.
- Check voltage between TCM connector terminal and ground.

Name	Connector	Terminal	Condition	Voltage (Approx.)
Power supply (memory back-up)	F104	28 - Ground	Always	Battery voltage

OK or NG

OK >> GO TO 3.



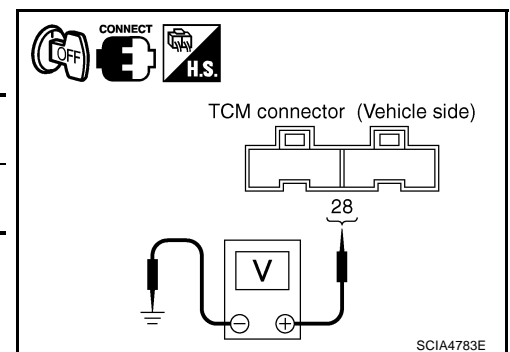

NG >> GO TO 4.



DTC P1701 TRANSMISSION CONTROL MODULE (POWER SUPPLY)

3. CHECK TCM POWER SOURCE, STEP 2

1. Turn ignition switch ON. (Do not start engine.)
2. Check voltage between TCM connector terminals and ground.

Name	Connector	Terminal	Condition	Voltage (Approx.)
Power supply	F103	10 - Ground		Battery voltage
				0V
Power supply		19 - Ground		Battery voltage
				0V
Power supply (memory back-up)	F104	28 - Ground	Always	Battery voltage

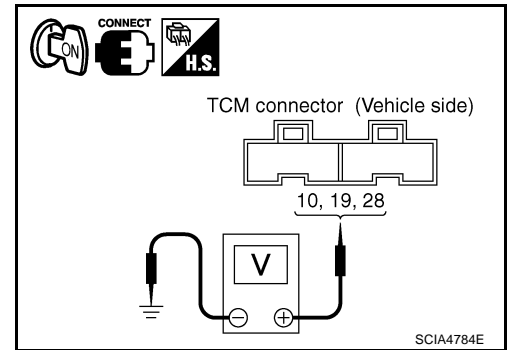

OK or NG

- OK >> GO TO 5.
 NG >> GO TO 4.

4. DETECT MALFUNCTIONING ITEM

Check the following.

- Harness for short or open between battery and TCM connector terminal 28
- Harness for short or open between ignition switch and TCM connector terminal 10, 19
- 10A fuse (No.83, located in the IPDM E/R)
- 10A fuse (No.21, located in the fuse block)
- Ignition switch. Refer to [PG-3, "POWER SUPPLY ROUTING CIRCUIT"](#).

OK or NG

- OK >> GO TO 5.
 NG >> Repair or replace damaged parts.

5. CHECK TCM GROUND CIRCUIT

1. Turn ignition switch OFF.
2. Disconnect TCM connector.
3. Check continuity between TCM connector terminals and ground.

Name	Connector	Terminal	Continuity
Ground	F104	25	Yes
		48	

OK or NG

- OK >> GO TO 6.
 NG >> Repair open circuit or short to ground or short to power in harness or connectors.

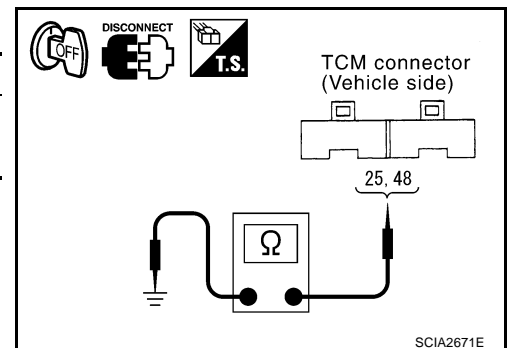

DTC P1701 TRANSMISSION CONTROL MODULE (POWER SUPPLY)

6. CHECK DTC

Check again. Refer to [CVT-152, "Diagnostic Procedure"](#) .

OK or NG

OK >> **INSPECTION END**
NG >> GO TO 7.

7. CHECK TCM

1. Check TCM input/output signal. Refer to [CVT-50, "TCM Input/Output Signal Reference Values"](#) .
2. If NG, re-check TCM pin terminals for damage or loose connection with harness connector.

OK or NG

OK >> **INSPECTION END**
NG >> Repair or replace damaged parts.

DTC P1705 THROTTLE POSITION SENSOR

DTC P1705 THROTTLE POSITION SENSOR

PFP:22620

Description

ECS00FAD

Electric throttle control actuator consists of throttle control motor, accelerator pedal position sensor, throttle position sensor etc. The actuator sends a signal to the ECM, and ECM sends the signal to TCM with CAN communication.

CONSULT-II Reference Value

ECS00FAE

Remarks: Specification data are reference values.

Item name	Condition	Display value (Approx.)
ACC PEDAL OPEN	Released accelerator pedal - Fully depressed accelerator pedal	0.0/8 - 8.0/8

On Board Diagnosis Logic

ECS00FAF

- This is not an OBD-II self-diagnostic item.
- Diagnostic trouble code "P1705 TP SEN/CIRC A/T" with CONSULT-II is detected when TCM does not receive the proper accelerator pedal position signals (input by CAN communication) from ECM.

Possible Cause

ECS00FAG

- ECM
- Harness or connectors
(CAN communication line is open or shorted.)

DTC Confirmation Procedure

ECS00FAH

NOTE:

If "DTC Confirmation Procedure" has been previously performed, always turn ignition switch OFF and wait at least 10 seconds before performing the next test.

After the repair, perform the following procedure to confirm the malfunction is eliminated.

④ WITH CONSULT-II

1. Turn ignition switch ON. (Do not start engine.)
2. Select "DATA MONITOR" mode for "TRANSMISSION" with CONSULT-II.
3. Depress accelerator pedal fully and release it, then wait for 5 seconds.
4. If DTC is detected, go to [CVT-156, "Diagnostic Procedure"](#).

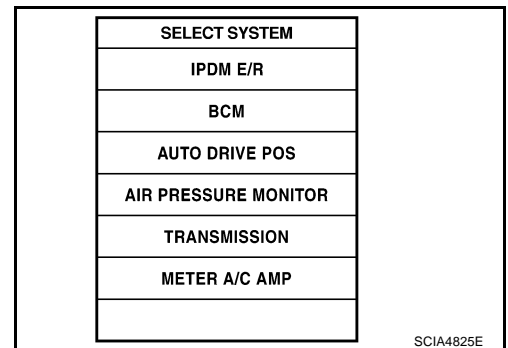

DTC P1705 THROTTLE POSITION SENSOR

ECS00FAI

Diagnostic Procedure

1. CHECK CAN COMMUNICATION LINE

Perform the self-diagnosis check. Refer to [CVT-58, "SELF-DIAGNOSTIC RESULT MODE"](#) .

Is any malfunction of the "U1000 CAN COMM CIRCUIT" indicated?

YES >> Check the CAN communication line. Refer to [CVT-65, "DTC U1000 CAN COMMUNICATION LINE"](#) .

NO >> GO TO 2.

2. CHECK INPUT SIGNAL

With CONSULT-II

1. Turn ignition switch ON. (Do not start engine.)
2. Select "ECU INPUT SIGNALS" in "DATA MONITOR" mode for "TRANSMISSION" with CONSULT-II.
3. Read out the value of "ACC PEDAL OPEN".

Item name	Condition	Display value (Approx.)
ACC PEDAL OPEN	Release your foot from the accelerator pedal.	0.0/8
	↓ Press the accelerator pedal all the way down.	8/8

DATA MONITOR	
MONITOR	NO. DTC
SEC HYDR SEN	0.47 v
PRI HYDR SEN	0.47 v
ATF TEMP SEN	1.92 v
VIGN SEN	10.7 v
ACC PEDAL OPEN	0.0 / 8

Δ	▽		
RECORD			
MODE	BACK	LIGHT	COPY

SCIA2277E

OK or NG

OK >> GO TO 4.

NG >> GO TO 3.

3. CHECK DTC WITH ECM

With CONSULT-II

1. Turn ignition switch ON. (Do not start engine.)
2. Select "SELF-DIAG RESULTS" mode for "ENGINE" with CONSULT-II. Refer to [EC-101, "SELF-DIAG RESULTS MODE"](#) .

OK or NG

OK >> GO TO 4.

NG >> Check the DTC Detected Item. Go to [EC-101, "SELF-DIAG RESULTS MODE"](#) .

SELECT SYSTEM
ENGINE
ABS
AIR BAG
BCM
ALL MODE 4WD
TRANSMISSION

SCIA2272E

4. CHECK DTC

Perform "DTC Confirmation Procedure". Refer to [CVT-155, "DTC Confirmation Procedure"](#) .

OK or NG

OK >> **INSPECTION END**

NG >> Repair or replace damaged parts.

DTC P1722 ESTM VEHICLE SPEED SIGNAL

DTC P1722 ESTM VEHICLE SPEED SIGNAL

PFP:47660

Description

ECS00FAJ

The vehicle speed signal is transmitted from ABS actuator and electric unit (control unit) to TCM by CAN communication line.

CONSULT-II Reference Value

ECS00FAK

Remarks: Specification data are reference values.

Item name	Condition	Display value
ESTM VSP SIG	During driving	Approximately matches the speedometer reading.
VEHICLE SPEED		

On Board Diagnosis Logic

ECS00FAL

- This is not an OBD-II self-diagnostic item.
- Diagnostic trouble code "P1722 ESTM VEH SPD SIG" with CONSULT-II is detected when TCM does not receive the proper vehicle speed signal (input by CAN communication) from ABS actuator and electric unit (control unit).

Possible Cause

ECS00FAM

- Harness or connectors
(Sensor circuit is open or shorted.)
- ABS actuator and electric unit (control unit)

DTC Confirmation Procedure

ECS00FAN

CAUTION:

Always drive vehicle at a safe speed.

NOTE:

If "DTC Confirmation Procedure" has been previously performed, always turn ignition switch OFF and wait at least 10 seconds before performing the next test.

After the repair, touch "ERASE" on "SELF-DIAG RESULTS" and then perform the following procedure to confirm the malfunction is eliminated.

Ⓟ WITH CONSULT-II

1. Turn ignition switch ON. (Do not start engine.)
2. Select "DATA MONITOR" mode for "TRANSMISSION" with CONSULT-II.
3. Start engine and maintain the following conditions for at least 5 consecutive seconds.
ACCELE POS: 1/8 or less
VHCL SPEED SE: 30 km/h (17 MPH) or more
4. If DTC is detected, go to [CVT-158, "Diagnostic Procedure"](#).

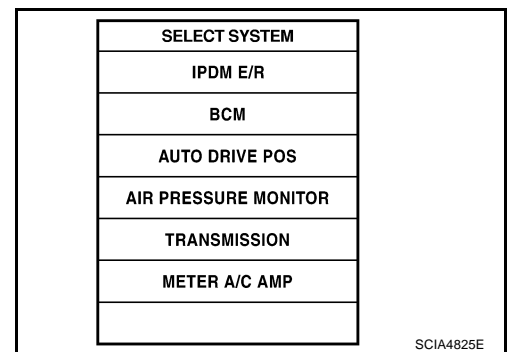

DTC P1722 ESTM VEHICLE SPEED SIGNAL

ECS00FA0

Diagnostic Procedure

1. CHECK CAN COMMUNICATION LINE

Perform the self-diagnosis check. Refer to [CVT-58, "SELF-DIAGNOSTIC RESULT MODE"](#) .

Is any malfunction of the "U1000 CAN COMM CIRCUIT" indicated?

- YES >> Check CAN communication line. Refer to [CVT-65, "DTC U1000 CAN COMMUNICATION LINE"](#) .
- NO >> GO TO 2.

2. CHECK ABS ACTUATOR AND ELECTRIC UNIT (CONTROL UNIT)

Perform ABS actuator and electric unit (control unit) self-diagnosis check. Refer to [BRC-33, "Self-Diagnosis"](#) .

OK or NG

- OK >> GO TO 3.
- NG >> Repair or replace damaged parts.

3. CHECK INPUT SIGNAL

 With CONSULT-II

1. Start engine.
2. Select "SELECTION FROM MENU" in "DATA MONITOR" mode for "TRANSMISSION" with CONSULT-II.
3. Drive vehicle and read out the value of "VEHICLE SPEED" and "ESTM VSP SIG".

Item name	Condition	Display value
ESTM VSP SIG	During driving	Approximately matches the speedometer reading.
VEHICLE SPEED		

4. Check if there is a great difference between the two values.

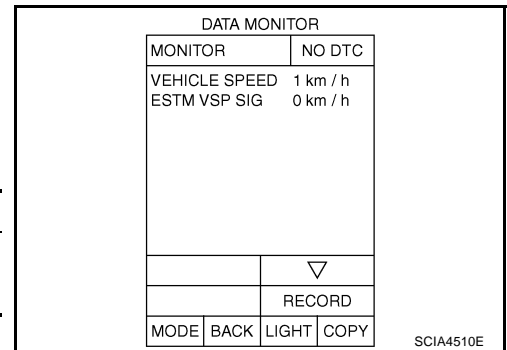

OK or NG

- OK >> GO TO 5.
- NG >> GO TO 4.

4. CHECK TCM

Check TCM input/output signal. Refer to [CVT-50, "TCM Input/Output Signal Reference Values"](#) .

OK or NG

- OK >> GO TO 5.
- NG >> Repair or replace damaged parts.

5. CHECK DTC

Perform "DTC Confirmation Procedure". Refer to [CVT-157, "DTC Confirmation Procedure"](#) .

OK or NG

- OK >> **INSPECTION END**
- NG >> GO TO 2.

DTC P1723 CVT SPEED SENSOR FUNCTION

DTC P1723 CVT SPEED SENSOR FUNCTION

PFP:31907

Description

ECS00FAP

The vehicle speed sensor CVT [output speed sensor (secondary speed sensor)] detects the revolution of the idler gear parking pawl lock gear and generates a pulse signal. The pulse signal is sent to the TCM, which converts it into vehicle speed.

The input speed sensor (primary speed sensor) detects the primary pulley revolution speed and sends a signal to the TCM.

On Board Diagnosis Logic

ECS00FAQ

- This is not an OBD-II self-diagnostic item.
- Diagnostic trouble code “P1723 CVT SPD SEN/FNCTN” with CONSULT-II is detected when there is a great difference between the vehicle speed signal and the secondary speed sensor signal.

CAUTION:

One of the “P0720 VEH SPD SEN/CIR AT”, the “P0715 INPUT SPD SEN/CIRC” or the “P0725 ENGINE SPEED SIG” is displayed with the DTC at the same time.

Possible Cause

ECS00FAR

- Harness or connectors
(Sensor circuit is open or shorted.)
- Output speed sensor (Secondary speed sensor)
- Input speed sensor (Primary speed sensor)
- Engine speed signal system

DTC Confirmation Procedure

ECS00FAS

CAUTION:

- Always drive vehicle at a safe speed.
- Be careful not to rev engine into the red zone on the tachometer.

NOTE:

If “DTC Confirmation Procedure” has been previously performed, always turn ignition switch OFF and wait at least 5 seconds before performing the next test.

After the repair, touch “ERASE” on “SELF-DIAG RESULTS” and then perform the following procedure to confirm the malfunction is eliminated.

Ⓟ WITH CONSULT-II

1. Turn ignition switch ON and select “DATA MONITOR” mode for “TRANSMISSION” with CONSULT-II.
2. Start engine and maintain the following conditions for at least 5 consecutive seconds.
VHCL SPEED SE: 10 km/h (6 MPH) or more
THRTL POS SEN: More than 1.2V
Selector lever: “D” position
ENG SPEED: 450 rpm or more
Driving location: Driving the vehicle uphill (increased engine load) will help maintain the driving conditions required for this test.
3. If DTC is detected, go to [CVT-160, "Diagnostic Procedure"](#).

SELECT SYSTEM
IPDM E/R
BCM
AUTO DRIVE POS
AIR PRESSURE MONITOR
TRANSMISSION
METER A/C AMP

SCIA4825E

DTC P1723 CVT SPEED SENSOR FUNCTION

ECS00FAT

Diagnostic Procedure

1. CHECK STEP MOTOR FUNCTION

Perform the self-diagnosis check. Refer to [CVT-58, "SELF-DIAGNOSTIC RESULT MODE"](#) .

Is a malfunction in the step motor function indicated in the results?

YES >> Repair or replace damaged parts. (Check the step motor function. Refer to [CVT-173, "DTC P1778 STEP MOTOR - FUNCTION"](#) .)

NO >> GO TO 2.

2. CHECK OUTPUT SPEED SENSOR (SECONDARY SPEED SENSOR SYSTEM) AND INPUT SPEED SENSOR (PRIMARY SPEED SENSOR) SYSTEM

Check secondary speed sensor system and primary speed sensor system. Refer to [CVT-91, "DTC P0720 VEHICLE SPEED SENSOR CVT \(SECONDARY SPEED SENSOR\)"](#) , [CVT-86, "DTC P0715 INPUT SPEED SENSOR CIRCUIT \(PRI SPEED SENSOR\)"](#) .

OK or NG

OK >> GO TO 3.

NG >> Repair or replace damaged parts.

3. CHECK ENGINE SPEED SIGNAL SYSTEM

Check engine speed signal system. Refer to [CVT-97, "DTC P0725 ENGINE SPEED SIGNAL"](#) .

OK or NG

OK >> GO TO 4.

NG >> Repair or replace damaged parts. Refer to [EC-606, "IGNITION SIGNAL"](#) .

4. DETECT MALFUNCTIONING ITEM

Check the following:

- Power supply and ground circuit for TCM. Refer to [CVT-148, "DTC P1701 TRANSMISSION CONTROL MODULE \(POWER SUPPLY\)"](#) .
- The TCM pin terminals for damage or loose connection with harness connector.

OK or NG

OK >> GO TO 5.

NG >> Repair or replace damaged parts.

5. CHECK DTC

Perform "DTC Confirmation Procedure". Refer to [CVT-159, "DTC Confirmation Procedure"](#) .

OK or NG

OK >> **INSPECTION END**

NG >> Replace TCM or transaxle assembly. Refer to [CVT-8, "Precautions for TCM and CVT Assembly Replacement"](#) , [CVT-226, "Removal and Installation"](#) .

DTC P1726 ELECTRIC THROTTLE CONTROL SYSTEM

DTC P1726 ELECTRIC THROTTLE CONTROL SYSTEM

PFP:23710

Description

ECS00FAU

Electric throttle control actuator consists of throttle control motor, accelerator pedal position sensor, throttle position sensor etc. The actuator sends a signal to the ECM, and ECM sends the signal to TCM with CAN communication.

On Board Diagnosis Logic

ECS00FAV

- This is not an OBD-II self-diagnostic item.
- Diagnostic trouble code "P1726 ELEC TH CONTROL" with CONSULT-II is detected when the electronically controlled throttle for ECM is malfunctioning.

Possible Cause

ECS00FAW

Harness or connectors
(Sensor circuit is open or shorted.)

DTC Confirmation Procedure

ECS00FAX

NOTE:

If "DTC Confirmation Procedure" has been previously performed, always turn ignition switch OFF and wait at least 10 seconds before performing the next test.

After the repair, touch "ERASE" on "SELF-DIAG RESULTS" and then perform the following procedure to confirm the malfunction is eliminated.

④ WITH CONSULT-II

1. Turn ignition switch ON. (Do not start engine.)
2. Select "DATA MONITOR" mode for "TRANSMISSION" with CONSULT-II.
3. Start engine and let it idle for 5 second.
4. If DTC is detected, go to [CVT-162. "Diagnostic Procedure"](#) .

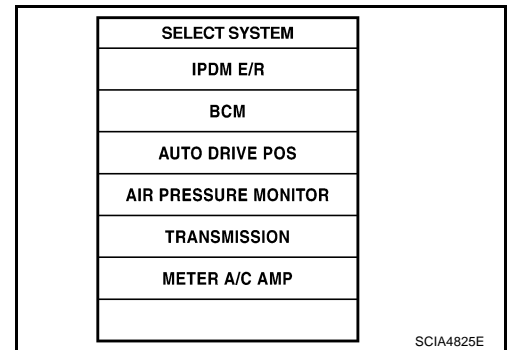

DTC P1726 ELECTRIC THROTTLE CONTROL SYSTEM

Diagnostic Procedure

ECS00FAY

1. CHECK DTC WITH ECM

④ With CONSULT-II

1. Turn ignition switch ON. (Do not start engine.)
2. Select "SELF-DIAG RESULTS" mode for "ENGINE" with CONSULT-II. Refer to [EC-101, "SELF-DIAG RESULTS MODE"](#).

OK or NG

OK >> GO TO 2.

NG >> Check the DTC Detected Item. Refer to [EC-101, "SELF-DIAG RESULTS MODE"](#).

- If CAN communication line is detected, go to [CVT-65, "DTC U1000 CAN COMMUNICATION LINE"](#).

SELECT SYSTEM
ENGINE
ABS
AIR BAG
ALL MODE AWD/4WD
IPDM E/R
BCM

SCIA4823E

2. CHECK DTC

Perform "DTC Confirmation Procedure". Refer to [CVT-161, "DTC Confirmation Procedure"](#).

OK or NG

OK >> **INSPECTION END**

NG >> GO TO 3.

3. DETECT MALFUNCTIONING ITEM

Check the following:

- The TCM pin terminals for damage or loose connection with harness connector.

OK or NG

OK >> Replace TCM. Refer to [CVT-8, "Precautions for TCM and CVT Assembly Replacement"](#).

NG >> Repair or replace damaged parts.

DTC P1740 LOCK-UP SELECT SOLENOID VALVE CIRCUIT

DTC P1740 LOCK-UP SELECT SOLENOID VALVE CIRCUIT

PDF:31941

Description

ECS00FAZ

- Lock-up select solenoid valve controls lock-up clutch pressure or forward clutch pressure (reverse brake pressure).
- When controlling lock-up clutch, the valve is turned OFF. When controlling forward clutch, it is turned ON.

CONSULT-II Reference Value

ECS00FB0

Item name	Condition	Display value
LUSEL SOL OUT	Selector lever in "P", "N" positions	ON
	Wait at least for 5 seconds with the selector lever in "R", "D" positions	OFF

On Board Diagnosis Logic

ECS00FB1

- This is an OBD-II self-diagnostic item.
- Diagnostic trouble code "P1740 LU-SLCT SOL/CIRC" with CONSULT-II is detected under the following conditions.
 - When TCM compares target value with monitor value and detects an irregularity.

Possible Cause

ECS00FB2

- Lock-up select solenoid valve
- Harness or connectors
(Solenoid circuit is open or shorted.)

DTC Confirmation Procedure

ECS00FB3

CAUTION:

Always drive vehicle at a safe speed.

NOTE:

If "DTC Confirmation Procedure" has been previously performed, always turn ignition switch OFF and wait at least 10 seconds before performing the next test.

After the repair, touch "ERASE" on "SELF-DIAG RESULTS" and then perform the following procedure to confirm the malfunction is eliminated.

WITH CONSULT-II

1. Turn ignition switch ON. (Do not start engine.)
2. Select "DATA MONITOR" mode for "TRANSMISSION" with CONSULT-II.
3. Start engine and maintain the following conditions for at least 5 consecutive seconds.
SELECTOR LEVER: "D" position and "N" position (At each time, wait for 5 seconds.)
4. If DTC is detected, go to [CVT-165, "Diagnostic Procedure"](#).

SELECT SYSTEM
IPDM E/R
BCM
AUTO DRIVE POS
AIR PRESSURE MONITOR
TRANSMISSION
METER A/C AMP

SCIA4825E

WITH GST





Follow the procedure "WITH CONSULT-II".

DTC P1740 LOCK-UP SELECT SOLENOID VALVE CIRCUIT

Wiring Diagram — CVT — L/USSV

EC500FB4

CVT-L/USSV-01

-  : DETECTABLE LINE FOR DTC
-  : NON-DETECTABLE LINE FOR DTC
-  : LHD MODELS
-  : RHD MODELS

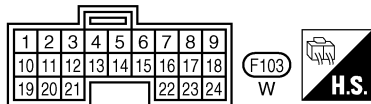
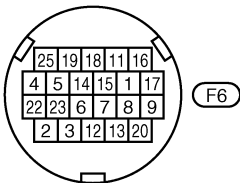
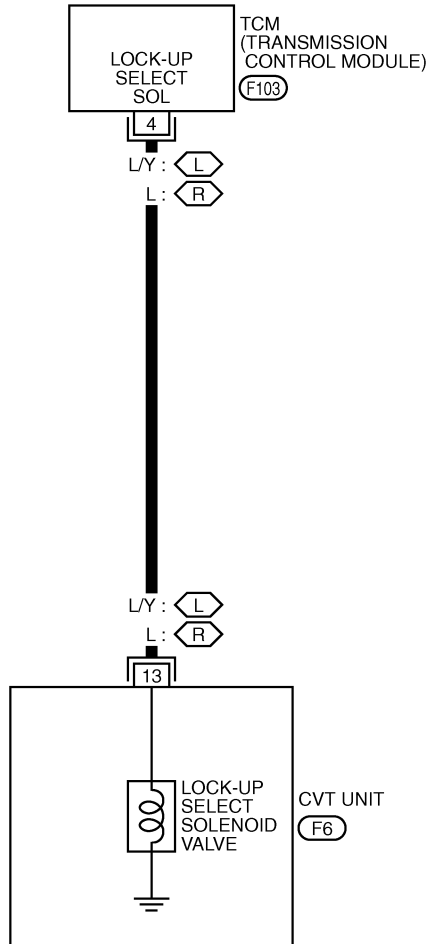

TCWB0145E

DTC P1740 LOCK-UP SELECT SOLENOID VALVE CIRCUIT

TCM terminal data are reference values, measured between each terminal and ground.

Terminal	Wire color	Item	Condition	Data (Approx.)
4	L/Y*1 L*2	Lock-up select solenoid valve	 Selector lever in "P", "N" positions	Battery voltage
			Wait at least for 5 seconds with the selector lever in "R", "D" positions	0V

*1: LHD models.

*2: RHD models.

Diagnostic Procedure

ECS00FB5

1. CHECK INPUT SIGNAL

With CONSULT-II

- Turn ignition switch ON.
- Select "SELECTION FROM MENU" in "DATA MONITOR" mode for "TRANSMISSION" with CONSULT-II.
- Read out the value of "LUSEL SOL OUT".

Item name	Condition	Display value
LUSEL SOL OUT	Selector lever in "P", "N" positions	ON
	Wait at least for 5 seconds with the selector lever in "R", "D" positions	OFF

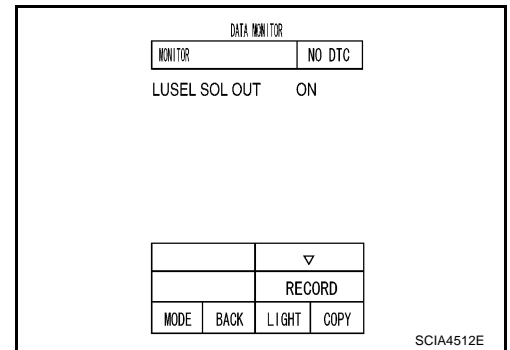

Without CONSULT-II

- Turn ignition switch ON.
- Check voltage between TCM connector terminal and ground.

Name	Connector	Terminal	Condition	Voltage (Approx.)
Lock-up select solenoid valve	F103	4 - Ground	Selector lever in "P", "N" positions	Battery voltage
			Wait at least for 5 seconds with the selector lever in "R", "D" positions	0V

- Turn ignition switch OFF.
- Disconnect the TCM connector.
- Check if there is continuity between connector terminal and ground.

OK or NG

- OK >> GO TO 5.
NG >> GO TO 2.

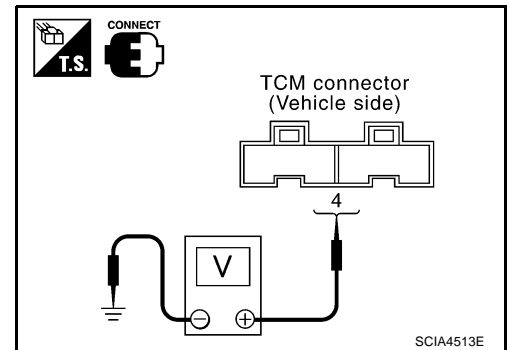

DTC P1740 LOCK-UP SELECT SOLENOID VALVE CIRCUIT

2. CHECK LOCK-UP SELECT SOLENOID VALVE CIRCUIT

1. Turn ignition switch OFF.
2. Disconnect TCM connector.
3. Check resistance between TCM connector terminal and ground.

Solenoid valve	Connector	Terminal	Resistance (Approx.)
Lock-up select solenoid valve	F103	4 - Ground	6 - 19 Ω

OK or NG

- OK >> GO TO 5.
 NG >> GO TO 3.

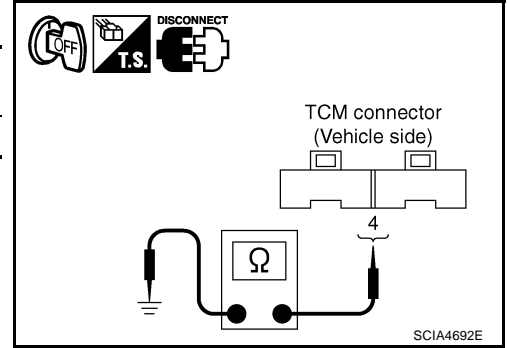

3. CHECK VALVE RESISTANCE

1. Turn ignition switch OFF.
2. Disconnect CVT unit harness connector.
3. Check resistance between CVT unit harness connector terminal and ground.

Solenoid valve	Connector	Terminal	Resistance (Approx.)
Lock-up select solenoid valve	F6	13 - Ground	6 - 19 Ω

OK or NG

- OK >> GO TO 4.
 NG >> Replace the transaxle assembly. Refer to [CVT-226](#), "[Removal and Installation](#)".

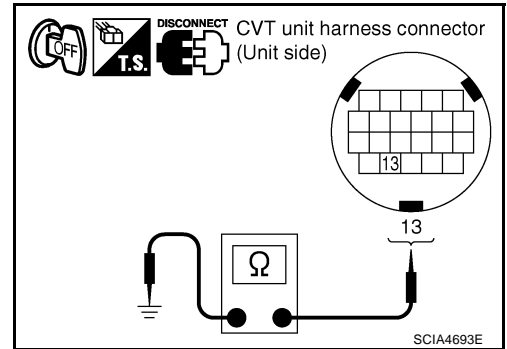

4. CHECK POWER SOURCE CIRCUIT

1. Turn ignition switch OFF.
2. Disconnect TCM connector.
3. Check continuity between TCM connector terminal and CVT unit harness connector terminal.

Item	Connector	Terminal	Continuity
TCM	F103	4	Yes
CVT unit harness connector	F6	13	

4. If OK, check harness for short to ground and short to power.
5. Reinstall any part removed.

OK or NG

- OK >> GO TO 5.
 NG >> Repair open circuit or short to ground or short to power in harness or connectors.

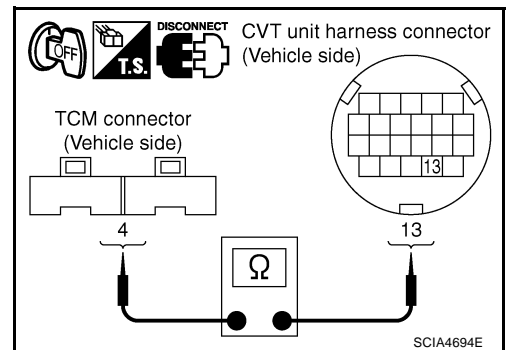

5. CHECK DTC

Perform "DTC Confirmation Procedure". Refer to [CVT-163](#), "[DTC Confirmation Procedure](#)".

OK or NG

- OK >> **INSPECTION END**
 NG >> GO TO 6.

DTC P1740 LOCK-UP SELECT SOLENOID VALVE CIRCUIT

6. CHECK TCM

1. Check TCM input/output signal. Refer to [CVT-50, "TCM Input/Output Signal Reference Values"](#) .
2. If NG, re-check TCM pin terminals for damage or loose connection with harness connector.

OK or NG

OK >> **INSPECTION END**

NG >> 1. Repair or replace damaged parts.

2. Replace TCM. Refer to [CVT-8, "Precautions for TCM and CVT Assembly Replacement"](#) .

Component Inspection LOCK-UP SELECT SOLENOID VALVE

ECS00FB6

1. Turn ignition switch OFF.
2. Disconnect CVT unit harness connector.
3. Check resistance between CVT unit harness connector terminal and ground.

Solenoid valve	Connector	Terminal	Resistance (Approx.)
Lock-up select solenoid valve	F6	13 - Ground	6 - 19 Ω

4. If NG, replace the transaxle assembly. Refer to [CVT-226, "Removal and Installation"](#) .

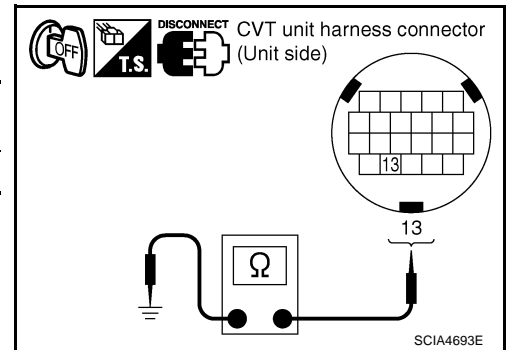

DTC P1745 LINE PRESSURE CONTROL

DTC P1745 LINE PRESSURE CONTROL

PFP:31036

Description

ECS00FB7

The pressure control solenoid valve A (line pressure solenoid valve) regulates the oil pump discharge pressure to suit the driving condition in response to a signal sent from the TCM.

On Board Diagnosis Logic

ECS00FB8

- This is not an OBD-II self-diagnostic item.
- Diagnostic trouble code "P1745 L/PRESS CONTROL" with CONSULT-II is detected when TCM detects the unexpected line pressure.

Possible Cause

ECS00FB9

TCM

DTC Confirmation Procedure

ECS00FBA

CAUTION:

- Always drive vehicle at a safe speed.
- Be careful not to rev engine into the red zone on the tachometer.

NOTE:

If "DTC Confirmation Procedure" has been previously performed, always turn ignition switch OFF and wait at least 5 seconds before performing the next test.

After the repair, touch "ERASE" on "SELF-DIAG RESULTS" and then perform the following procedure to confirm the malfunction is eliminated.

WITH CONSULT-II

1. Turn ignition switch ON and select "DATA MONITOR" mode for "TRANSMISSION" with CONSULT-II.
2. Make sure that output voltage of CVT fluid temperature sensor is within the range below.
FLUID TEMP SEN: 1.0 - 2.0V
If out of range, drive the vehicle to decrease the voltage (warm up the fluid) or stop engine to increase the voltage (cool down the fluid)
3. If DTC is detected, go to [CVT-168, "Diagnostic Procedure"](#).

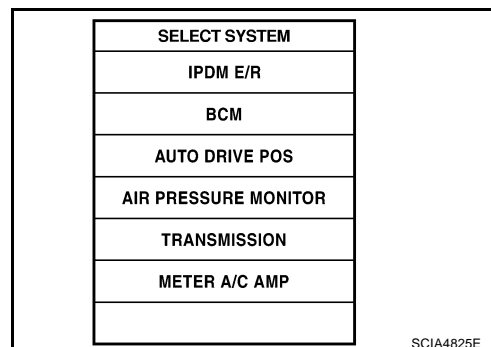

Diagnostic Procedure

ECS00FBB

1. CHECK DTC

1. Turn ignition switch ON. (Do not start engine.)
2. Select "SELF-DIAG RESULTS" mode for "TRANSMISSION" with CONSULT-II.
3. Erase self-diagnostic results. Refer to [CVT-60, "How to Erase Self-diagnostic Results"](#).
4. Turn ignition switch OFF, and wait for 5 seconds or more.
5. Start engine.
6. Confirm self-diagnostic results again. Refer to [CVT-58, "SELF-DIAGNOSTIC RESULT MODE"](#).

Is the "P1745 L/PRESS CONTROL" displayed?

YES >> Replace TCM. Refer to [CVT-8, "Precautions for TCM and CVT Assembly Replacement"](#).

NO >> **INSPECTION END**

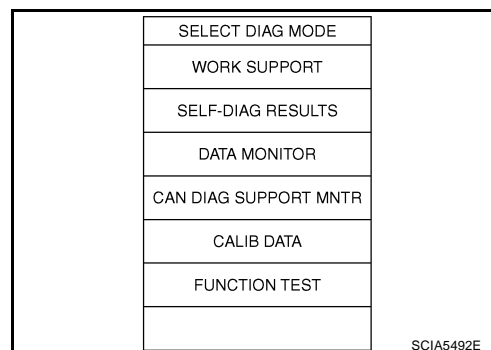

DTC P1777 STEP MOTOR - CIRCUIT

DTC P1777 STEP MOTOR - CIRCUIT

PFP:31020

Description

ECS00FBC

- The step motor changes the step with turning 4 coils ON/OFF according to the signal from TCM. As a result, the flow of line pressure to primary pulley is changed and pulley ratio is controlled.

CONSULT-II Reference Value

ECS00FBD

Remarks: Specification data are reference values.

Item name	Condition	Display value (Approx.)
STM STEP	During driving	-20 step - 190 step
SMCOIL A		Changes ON↔OFF.
SMCOIL B		Changes ON↔OFF.
SMCOIL C		Changes ON↔OFF.
SMCOIL D		Changes ON↔OFF.

On Board Diagnosis Logic

ECS00FBE

- This is an OBD-II self-diagnostic item.
- Diagnostic trouble code "P1777 STEP MOTR CIRC" with CONSULT-II is detected under the following conditions.
 - When operating step motor ON and OFF, there is no proper change in the voltage of TCM terminal which corresponds to it.

Possible Cause

ECS00FBF

- Step motor
- Harness or connectors
(Step motor circuit is open or shorted.)

DTC Confirmation Procedure

ECS00FBG

CAUTION:

Always drive vehicle at a safe speed.

NOTE:

If "DTC Confirmation Procedure" has been previously performed, always turn ignition switch OFF and wait at least 5 seconds before performing the next test.

After the repair, touch "ERASE" on "SELF-DIAG RESULTS" and then perform the following procedure to confirm the malfunction is eliminated.

WITH CONSULT-II

- Turn ignition switch ON and select "DATA MONITOR" mode for "TRANSMISSION" with CONSULT-II.
- Drive vehicle for at least 5 consecutive seconds.
- If DTC is detected, go to [CVT-171, "Diagnostic Procedure"](#).

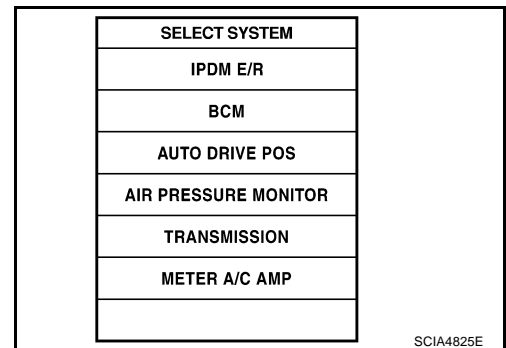

WITH GST

Follow the procedure "WITH CONSULT-II".

DTC P1777 STEP MOTOR - CIRCUIT

ECS00FBH

Wiring Diagram — CVT — STM

CVT-STM-01

: DETECTABLE LINE FOR DTC
 : NON-DETECTABLE LINE FOR DTC

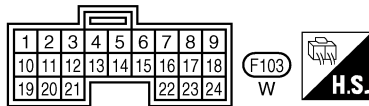
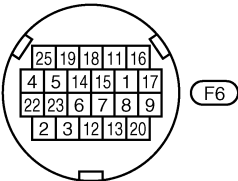
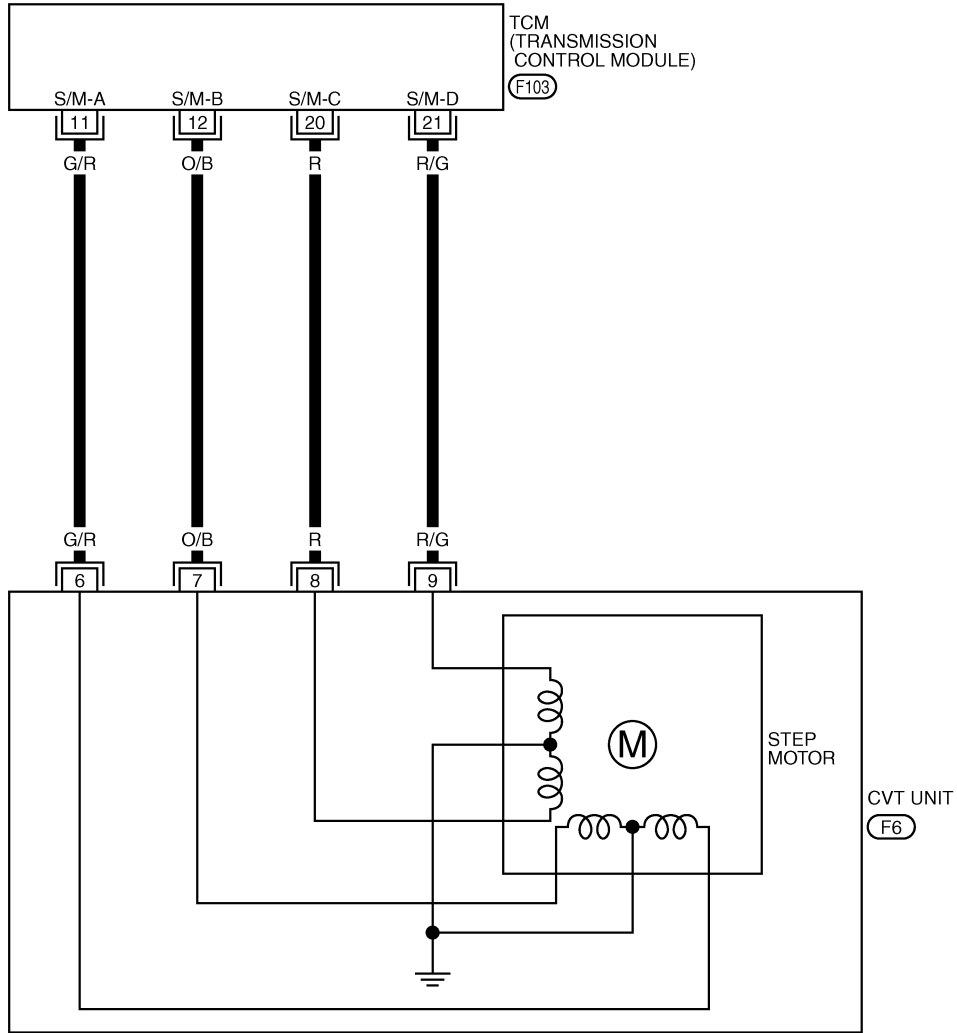

TCWA0256E

DTC P1777 STEP MOTOR - CIRCUIT

TCM terminals data are reference values.

Terminal	Wire color	Item	Condition	Data (Approx.)
11	G/R	Step motor A	Within 2 seconds after ignition switch ON, the time measurement by using the pulse width measurement function (Hi level) of CONSULT-II.*1 CAUTION: Connect the diagnosis data link cable to the vehicle diagnosis connector. *1: A circuit tester cannot be used to test this item.	30.0 msec
12	O/B	Step motor B		10.0 msec
20	R	Step motor C		30.0 msec
21	R/G	Step motor D		10.0 msec

Diagnostic Procedure

ECS00FBI

1. CHECK INPUT SIGNAL

With CONSULT-II

- Start engine.
- Select "SELECTION FROM MENU" in "DATA MONITOR" mode for "TRANSMISSION" with CONSULT-II.
- Start vehicle and read out the value of "STM STEP", "SMCOIL A", "SMCOIL B", "SMCOIL C", and "SMCOIL D".

Item name	Condition	Display value (Approx.)
STM STEP	During driving	-20 step - 190 step
SMCOIL A		Changes ON⇔OFF.
SMCOIL B		Changes ON⇔OFF.
SMCOIL C		Changes ON⇔OFF.
SMCOIL D		Changes ON⇔OFF.

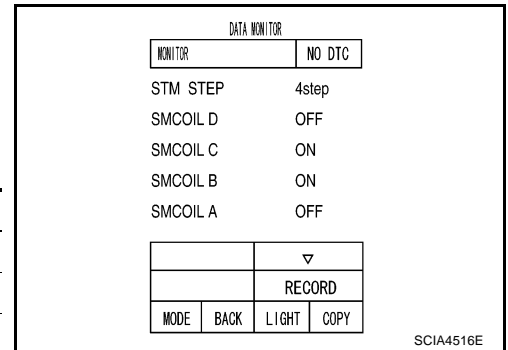

OK or NG

- OK >> GO TO 4.
NG >> GO TO 2.

2. CHECK STEP MOTOR CIRCUIT

- Turn ignition switch OFF.
- Disconnect CVT unit connector and TCM connector.
- Check continuity between TCM connector terminals and CVT unit harness connector terminals.

Item	Connector	Terminal	Continuity
TCM	F103	11	Yes
CVT unit harness connector	F6	6	
TCM	F103	12	Yes
CVT unit harness connector	F6	7	
TCM	F103	20	Yes
CVT unit harness connector	F6	8	
TCM	F103	21	Yes
CVT unit harness connector	F6	9	

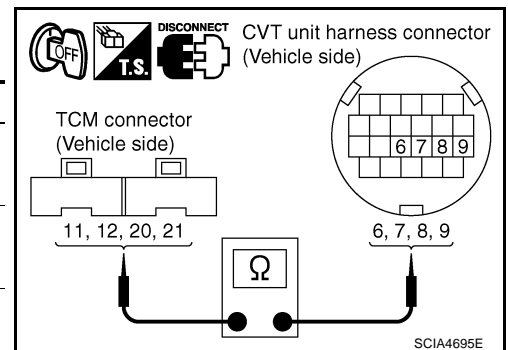

- If OK, check harness for short to ground and short to power.
- If OK, check continuity between body ground and CVT assembly.
- Reinstall any part removed.

OK or NG

- OK >> GO TO 3.
NG >> Repair open circuit or short to ground or short to power in harness or connectors.

DTC P1777 STEP MOTOR - CIRCUIT

3. CHECK STEP MOTOR

Check step motor Refer to [CVT-172, "Component Inspection"](#) .

OK or NG

- OK >> GO TO 4.
- NG >> Repair or replace damaged parts.

4. CHECK DTC

Perform "DTC Confirmation Procedure". Refer to [CVT-169, "DTC Confirmation Procedure"](#) .

OK or NG

- OK >> **INSPECTION END**
- NG >> GO TO 5.

5. CHECK TCM

1. Check TCM input/output signal. Refer to [CVT-50, "TCM Input/Output Signal Reference Values"](#) .
2. If NG, re-check TCM pin terminals for damage or loose connection with harness connector.

OK or NG

- OK >> **INSPECTION END**
- NG >> Repair or replace damaged parts.

Component Inspection STEP MOTOR

ECS00FBJ

1. Turn ignition switch OFF.
2. Disconnect CVT unit harness connector.
3. Check resistance between CVT unit harness connector terminals and ground.

Control valve	Connector	Terminal	Resistance (Approx.)
Step motor	F6	6 - 7	30Ω
		8 - 9	
		6 - Ground	15Ω
		7 - Ground	
		8 - Ground	
		9 - Ground	

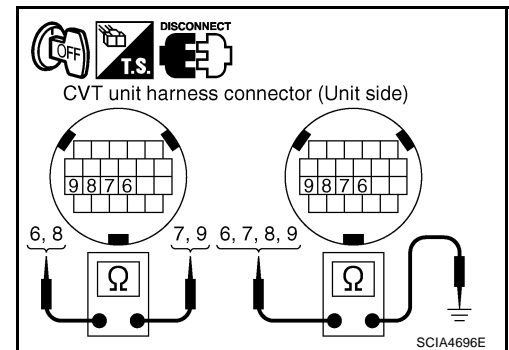

4. If NG, replace the transaxle assembly. Refer to [CVT-226, "Removal and Installation"](#) .

DTC P1778 STEP MOTOR - FUNCTION

DTC P1778 STEP MOTOR - FUNCTION

PFP:31947

Description

ECS00FBK

- The step motor's 4 aspects of ON/OFF change according to the signal from TCM. As a result, the flow of line pressure to primary pulley is changed and pulley ratio is controlled.
- This diagnosis item is detected when electrical system is OK, but mechanical system is NG.
- This diagnosis item is detected when the state of the changing the speed mechanism in unit does not operate normally.

CONSULT-II Reference Value

ECS00FBL

Remarks: Specification data are reference values.

Item name	Condition	Display value (Approx.)
STM STEP	During driving	-20 step - 190 step
GEAR RATIO		2.37 - 0.43

On Board Diagnosis Logic

ECS00FBM

- This is an OBD-II self-diagnostic item.
- Diagnostic trouble code "P1778 STEP MOTR/FNC" with CONSULT-II is detected under the following conditions.
 - When not changing the pulley ratio according to the instruction of TCM.

Possible Cause

ECS00FBN

Step motor

DTC Confirmation Procedure

ECS00FBO

CAUTION:

- Always drive vehicle at a safe speed.
- Be careful not to rev engine into the red zone on the tachometer.
- Before starting "DTC Confirmation Procedure", confirm "Hi" or "Mid" or "Low" fixation by "PRI SPEED" and "VEHICLE SPEED" on "DATA MONITOR MODE".
- If hi-gear fixation occurred, go to [CVT-174. "Diagnostic Procedure"](#).

NOTE:

If "DTC Confirmation Procedure" has been previously performed, always turn ignition switch OFF and wait at least 5 seconds before performing the next test.

After the repair, touch "ERASE" on "SELF-DIAG RESULTS" and then perform the following procedure to confirm the malfunction is eliminated.

Ⓟ WITH CONSULT-II

1. Turn ignition switch ON and select "DATA MONITOR" mode for "TRANSMISSION" with CONSULT-II.
2. Make sure that output voltage of CVT fluid temperature sensor is within the range below.

FLUID TEMP SEN: 1.0 - 2.0V

If out of range, drive the vehicle to decrease the voltage (warm up the fluid) or stop engine to increase the voltage (cool down the fluid)

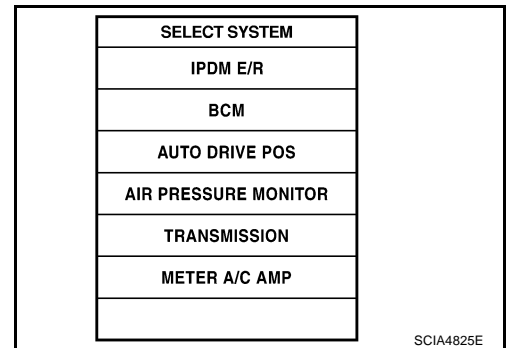

DTC P1778 STEP MOTOR - FUNCTION

3. Select "DATA MONITOR" mode for "TRANSMISSION" with CONSULT-II.
4. Start engine and maintain the following conditions for at least 30 consecutive seconds.
TEST START FROM 0 km/h (0 MPH)
CONSTANT ACCELERATION: Keep 30 sec or more
VEHICLE SPEED: 10 km/h (6 MPH) or more
ACC PEDAL OPEN: More than 1/8
Selector lever: "D" position
ENG SPEED: 450 rpm or more
5. If DTC is detected, go to [CVT-174, "Diagnostic Procedure"](#).

SELECT DIAG MODE
WORK SUPPORT
SELF-DIAG RESULTS
DATA MONITOR
CAN DIAG SUPPORT MNTR
CALIB DATA
FUNCTION TEST

SCIA5492E

WITH GST

Follow the procedure "WITH CONSULT-II".

Diagnostic Procedure

ECS00FBP

1. CHECK STEP MOTOR

With CONSULT-II

It is monitoring whether "GEAR RATIO: 2.37 - 0.43" changes similarly to "STM STEP: -20 - 190" by "DATA MONITOR" mode. Refer to [CVT-61, "DATA MONITOR MODE"](#).

Without CONSULT-II

Inspect the engine speed (rise and descend), vehicle speed, throttle opening angle, and check shift change. Refer to [CVT-232, "Vehicle Speed at Which Gear Shifting Occurs"](#).

OK or NG

OK >> **INSPECTION END**

NG >> Replace the transaxle assembly. Refer to [CVT-226, "Removal and Installation"](#).

CVT INDICATOR CIRCUIT

CVT INDICATOR CIRCUIT

PDF:24810

Description

ECS00FBV

TCM sends the switch signals to unified meter and A/C amp via CAN communication line. Then manual mode switch position is indicated on the CVT indicator.

CONSULT-II Reference Value

ECS00FBW

Item name	Condition	Display value
M GEAR POS	During driving	1, 2, 3, 4, 5, 6

Diagnostic Procedure

ECS00FBX

1. CHECK INPUT SIGNAL

Ⓟ With CONSULT-II

1. Start engine.
2. Select "MAIN SIGNALS" in "DATA MONITOR" mode for "TRANSMISSION" with CONSULT-II and read out the value of "M GEAR POS".
3. Drive vehicle in the manual mode, and confirm that the actual gear position and the meter's indication of the position mutually coincide when the select lever is shifted to the "+ (up)" or "- (down)" side (1st ↔ 6th gear).

OK or NG

- OK >> **INSPECTION END**
 NG >> Check the following.

CVT INDICATOR SYMPTOM CHART

Items	Presumed location of trouble
The actual gear position does not change, or shifting into the manual mode is not possible (no gear shifting in the manual mode possible). The CVT position indicator is not indicated.	Manual mode switch Refer to CVT-125, "DTC P0826 MANUAL MODE SWITCH CIRCUIT" . CVT main system (Fail-safe function actuated) ● Refer to CVT-58, "SELF-DIAGNOSTIC RESULT MODE" .
The actual gear position changes, but the CVT position indicator is not indicated.	Perform the self-diagnosis function. ● Refer to CVT-58, "SELF-DIAGNOSTIC RESULT MODE" .
The actual gear position and the indication on the CVT position indicator do not coincide.	Perform the self-diagnosis function. ● Refer to CVT-58, "SELF-DIAGNOSTIC RESULT MODE" .
Only a specific position or positions is/are not indicated on the CVT position indicator.	Check the meter control unit. Refer to DI-4, "COMBINATION METERS" .

TROUBLE DIAGNOSIS FOR SYMPTOMS

PFP:00007

TROUBLE DIAGNOSIS FOR SYMPTOMS

Wiring Diagram — CVT — NONDTC (LHD Models)

ECS00FBY

CVT-NONDTC-01

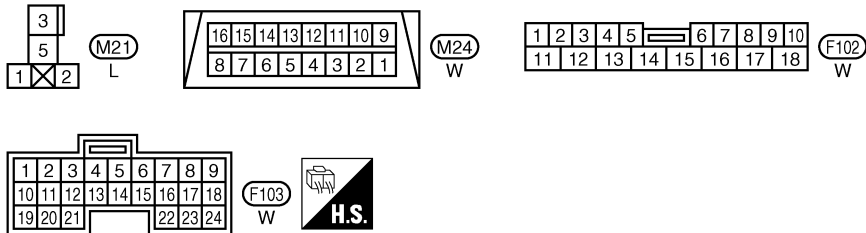
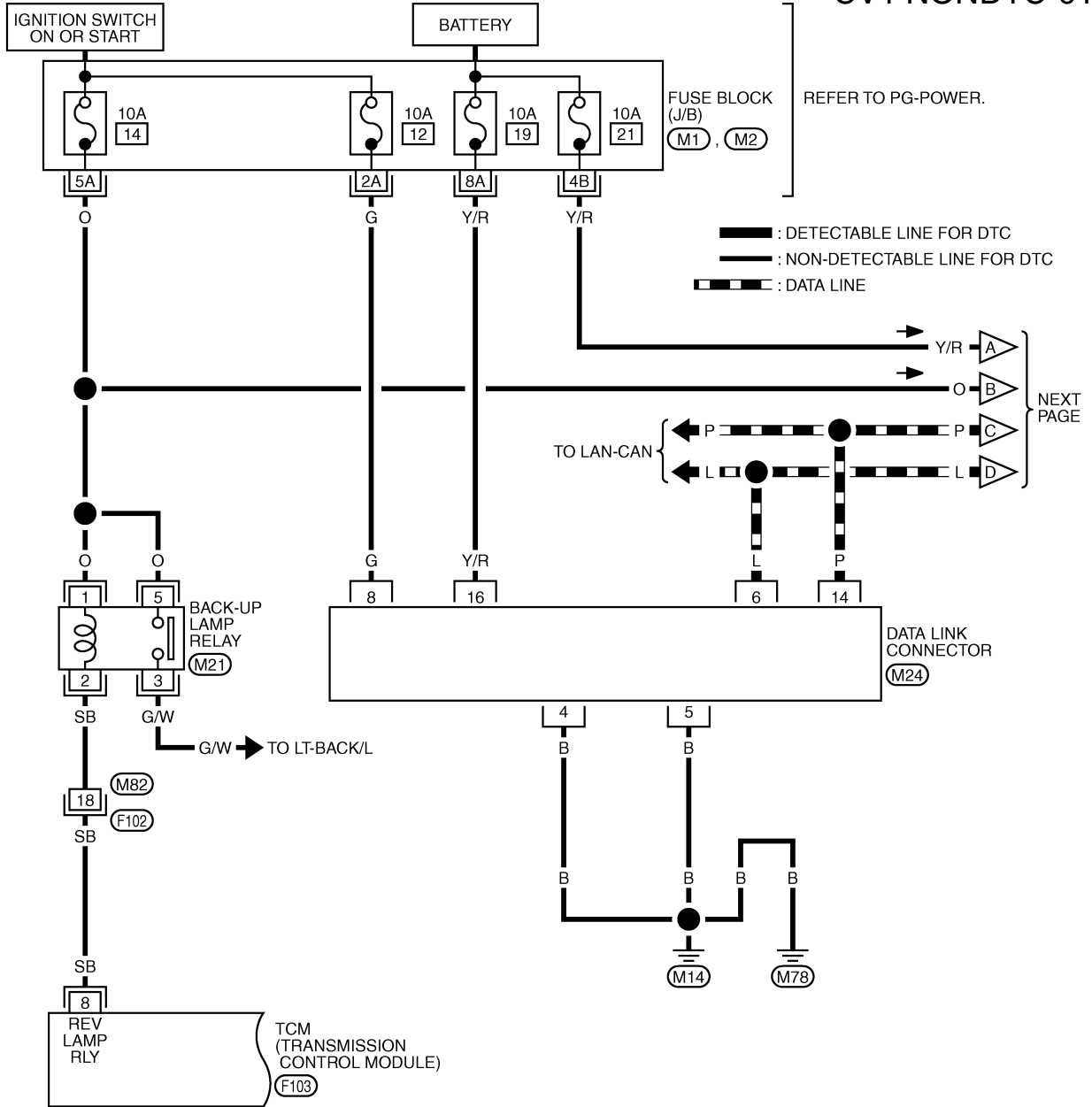

REFER TO THE FOLLOWING.

(M1), (M2) - FUSE BLOCK-JUNCTION BOX (J/B)

TROUBLE DIAGNOSIS FOR SYMPTOMS

CVT-NONDTC-02

A
B
C
D
E
F
G
H
I
J
K
L
M

CVT

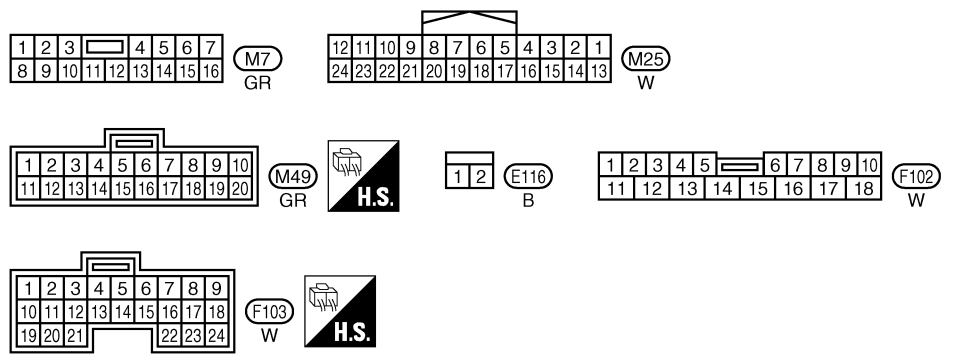
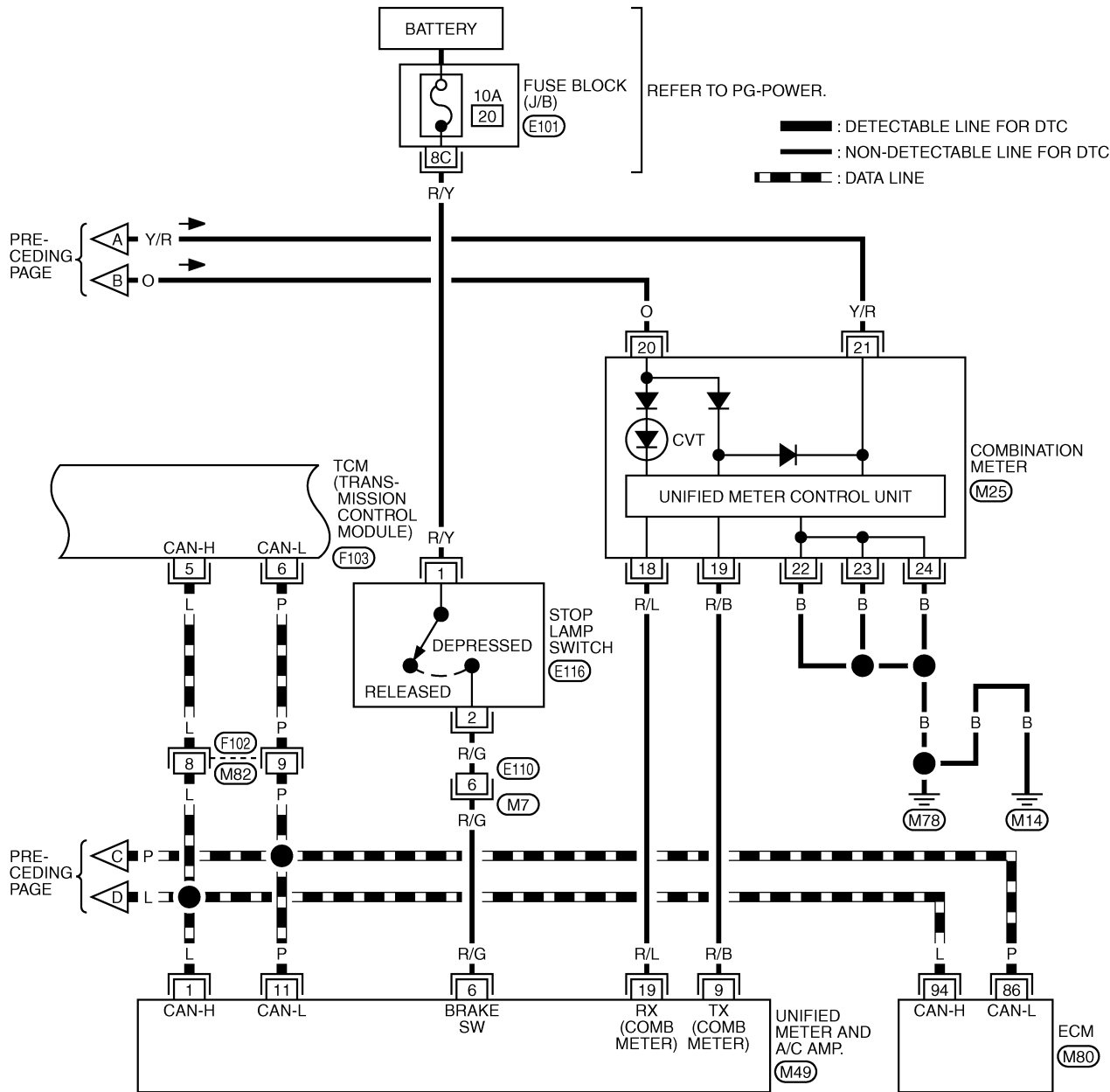

REFER TO THE FOLLOWING.
 (E101) - FUSE BLOCK-JUNCTION BOX (J/B)
 (M80) - ELECTRICAL UNITS

TCWB0147E

TROUBLE DIAGNOSIS FOR SYMPTOMS



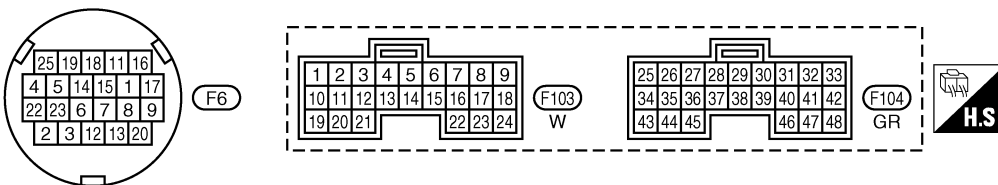
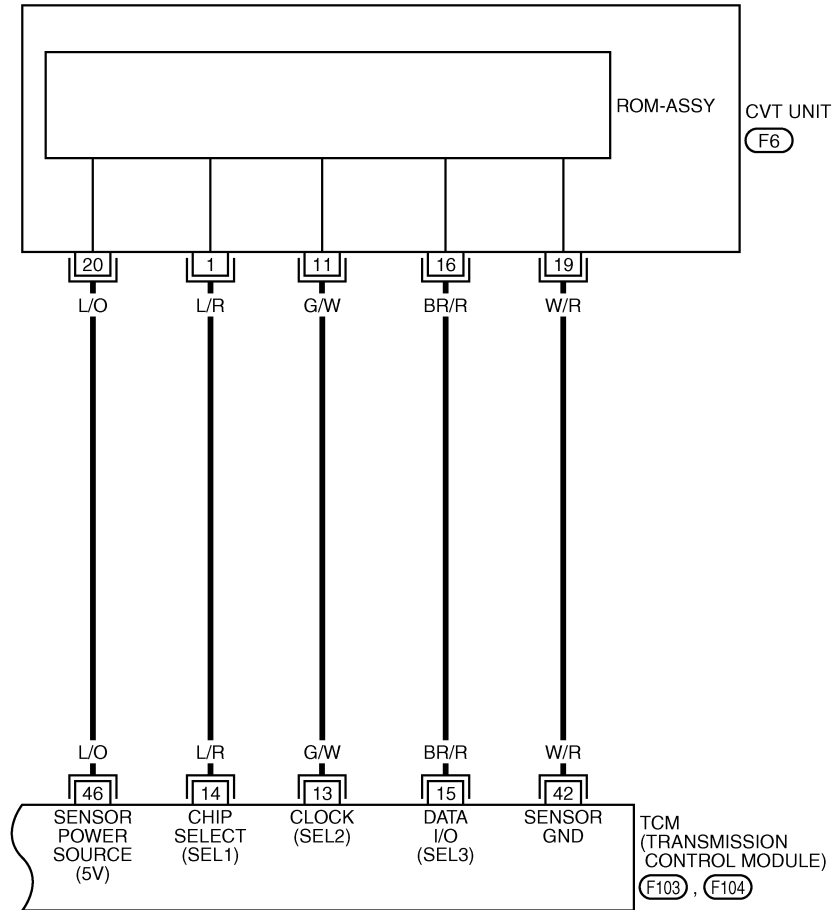

CVT-NONDTC-03

: DETECTABLE LINE FOR DTC
 : NON-DETECTABLE LINE FOR DTC



TROUBLE DIAGNOSIS FOR SYMPTOMS

TCM terminal data are reference values, measured between each terminal and ground.

Terminal	Wire color	Item	Condition	Data (Approx.)
5	L	CAN H	—	—
6	P	CAN L	—	—
8	SB	Back-up lamp relay	 Selector lever in "R" position.	0V
			 Selector lever in other positions.	Battery voltage
13	G/W	ROM assembly	—	—
14	L/R	ROM assembly	—	—
15	BR/R	ROM assembly	—	—
42	W/R	Sensor ground	Always	0V
46	L/O	Sensor power	 style="text-align: center;">—	4.5 - 5.5V
			 style="text-align: center;">—	0V

A
B
CVT
D
E
F
G
H
I
J
K
L
M

TROUBLE DIAGNOSIS FOR SYMPTOMS

Wiring Diagram — CVT — NONDTC (RHD Models)

ECS00G4I

CVT-NONDTC-04

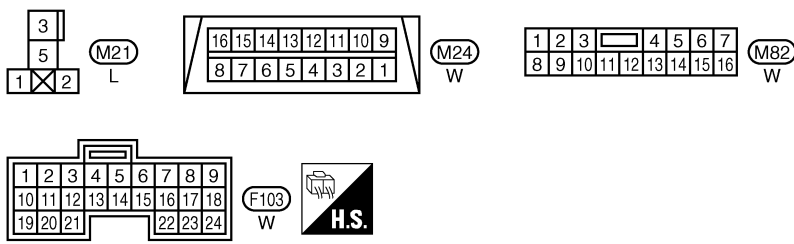
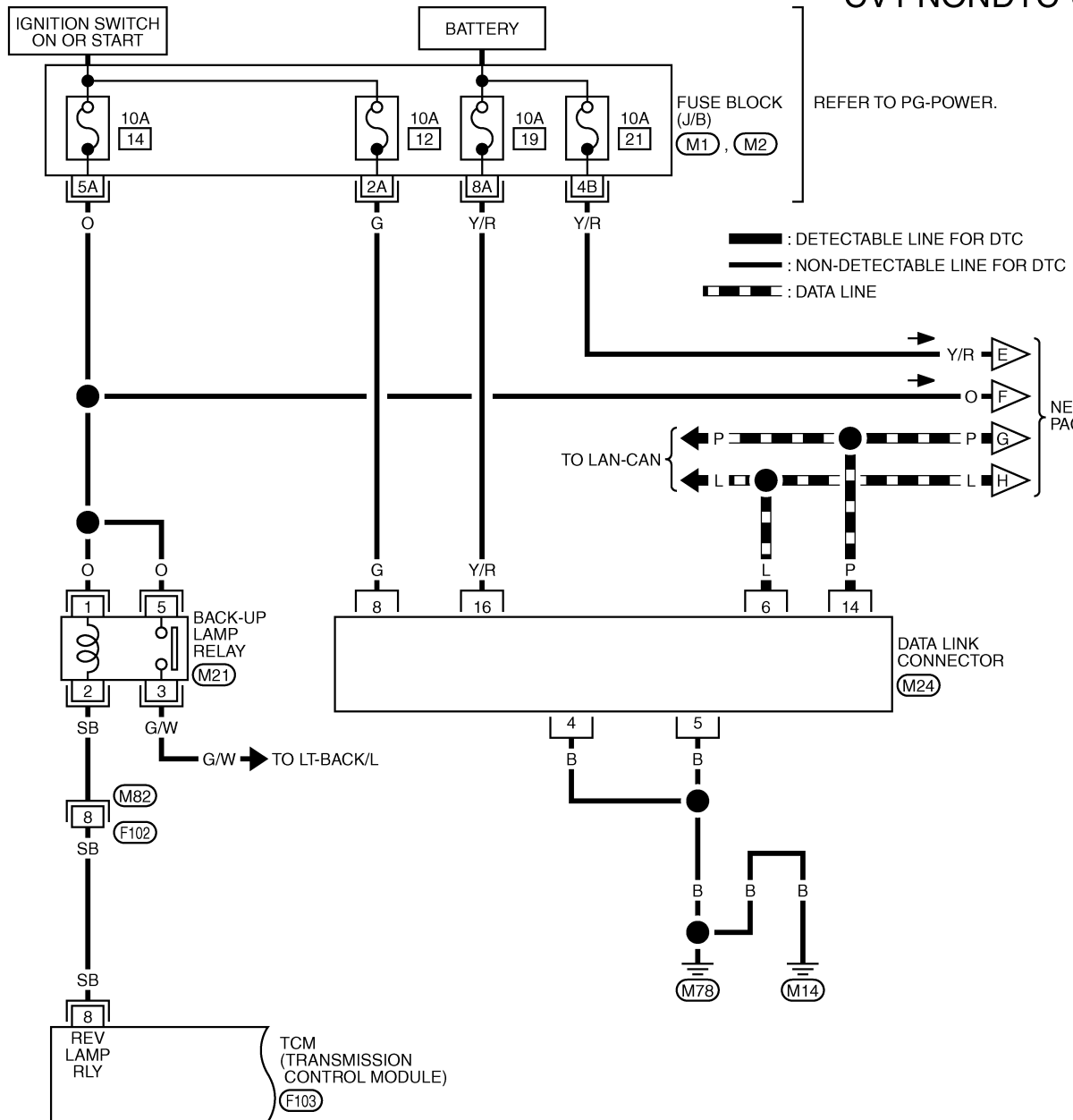

REFER TO THE FOLLOWING.
(M1), (M2) - FUSE BLOCK-JUNCTION BOX (J/B)

TROUBLE DIAGNOSIS FOR SYMPTOMS

CVT-NONDTC-05

A
B
C
D
E
F
G
H
I
J
K
L
M

CVT

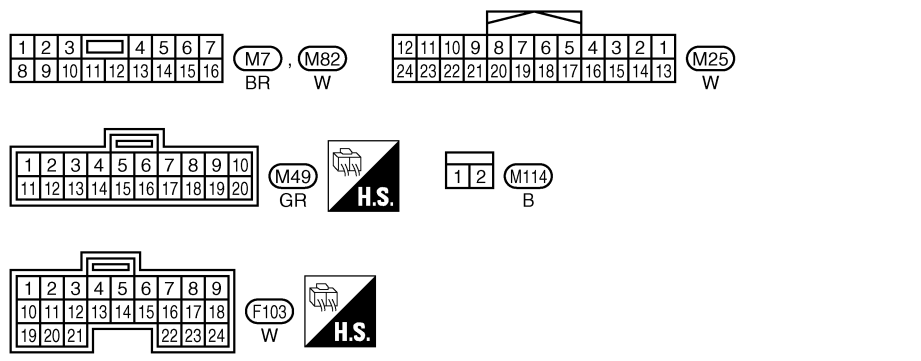
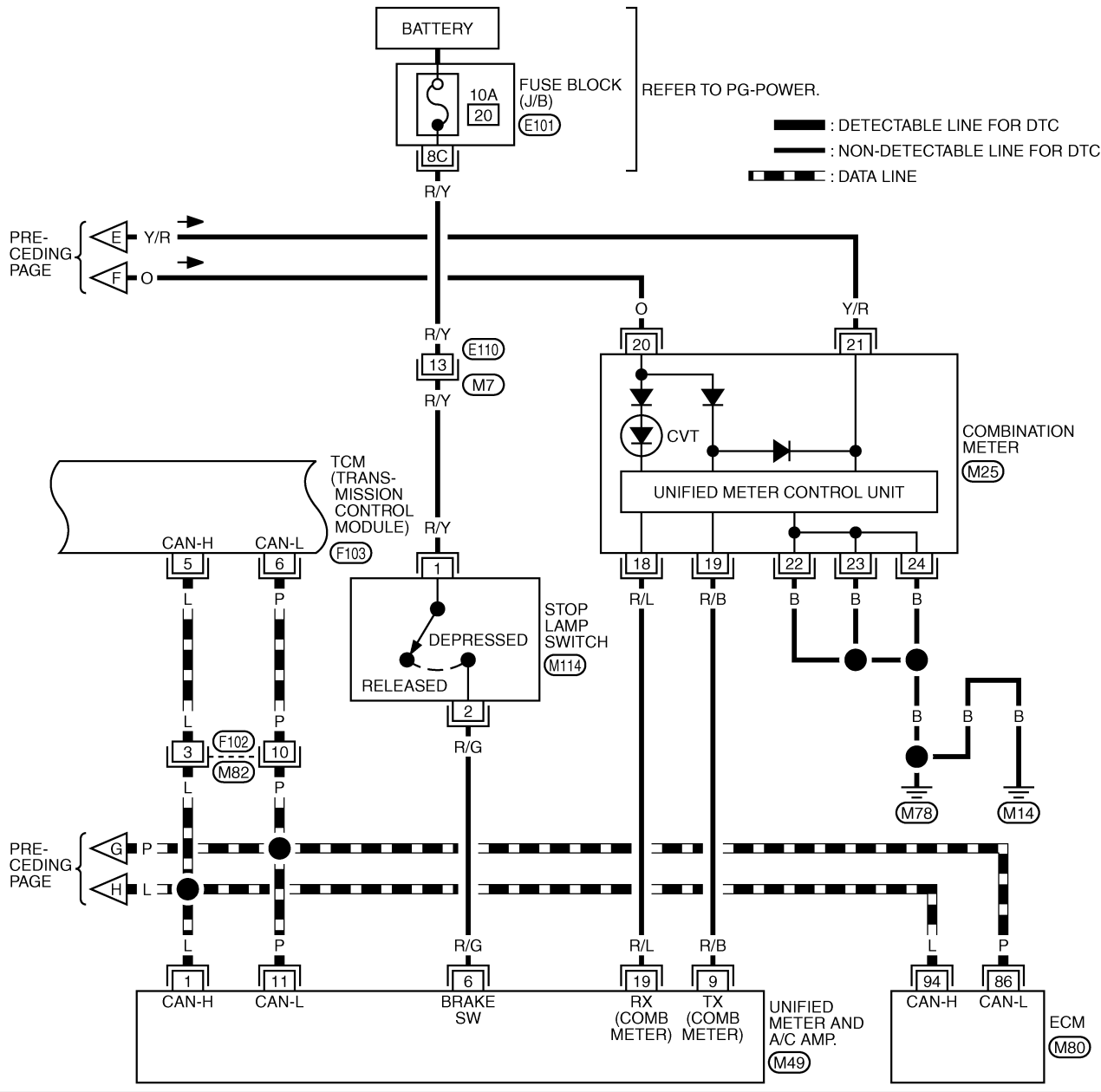

REFER TO THE FOLLOWING.
 (E101) -FUSE BLOCK-JUNCTION BOX (J/B)
 (M80) -ELECTRICAL UNITS

TROUBLE DIAGNOSIS FOR SYMPTOMS

CVT-NONDTC-06

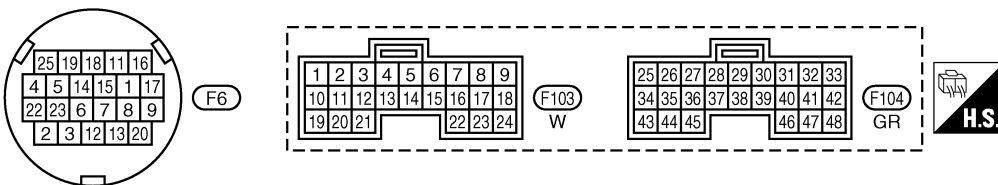
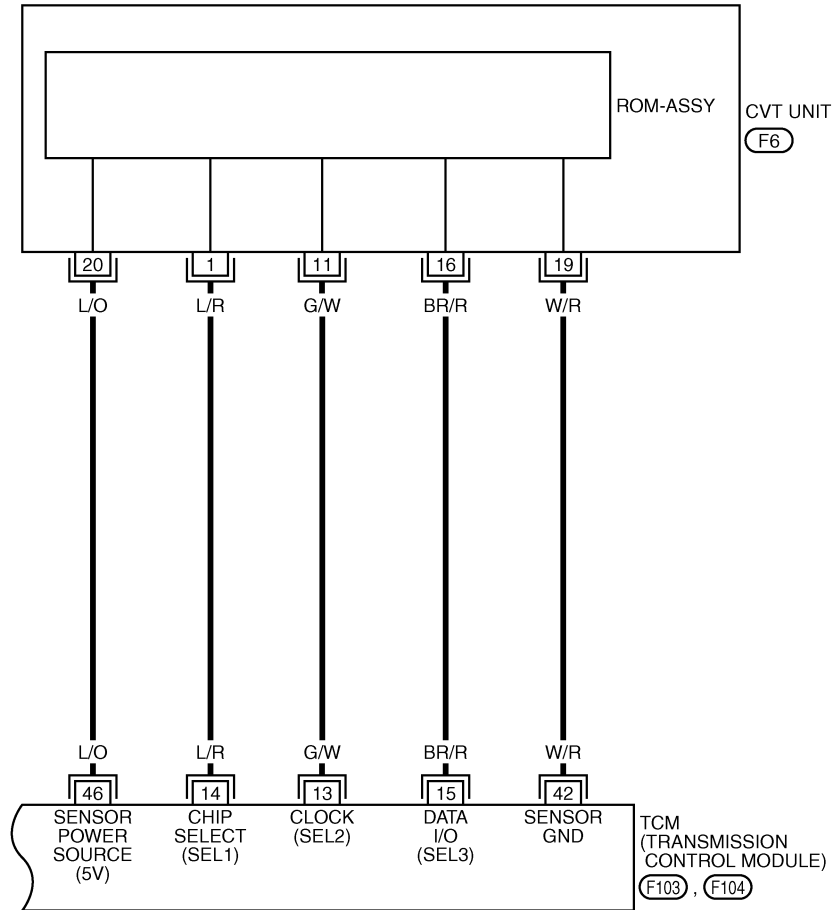

: DETECTABLE LINE FOR DTC
 : NON-DETECTABLE LINE FOR DTC



TCWB0150E

TROUBLE DIAGNOSIS FOR SYMPTOMS

TCM terminal data are reference values, measured between each terminal and ground.

Terminal	Wire color	Item	Condition		Data (Approx.)
5	L	CAN H	—		—
6	P	CAN L	—		—
8	SB	Back-up lamp relay		Selector lever in "R" position.	0V
				Selector lever in other positions.	Battery voltage
13	G/W	ROM assembly	—		—
14	L/R	ROM assembly	—		—
15	BR/R	ROM assembly	—		—
42	W/R	Sensor ground	Always		0V
46	L/O	Sensor power		—	4.5 - 5.5V
				—	0V

A
B
CVT
D
E
F
G
H
I
J
K
L
M

TROUBLE DIAGNOSIS FOR SYMPTOMS

ECS00FBZ

CVT Indicator Lamp Does Not Come On

SYMPTOM:

CVT indicator lamp does not come on for about 2 seconds when turning ignition switch to ON.

DIAGNOSTIC PROCEDURE

1. CHECK CAN COMMUNICATION LINE

Perform the self-diagnosis check. Refer to [CVT-58, "SELF-DIAGNOSTIC RESULT MODE"](#) .

Is any malfunction of the "U1000 CAN COMM CIRCUIT" indicated in the results?

- YES >> Check CAN communication line. Refer to [CVT-65, "DTC U1000 CAN COMMUNICATION LINE"](#) .
NO >> GO TO 2.

2. CHECK TCM POWER SOURCE

1. Turn ignition switch ON.
2. Check voltage between TCM connector terminals and ground. Refer to [CVT-149, "Wiring Diagram — CVT — POWER \(LHD Models\)"](#) , [CVT-151, "Wiring Diagram — CVT — POWER \(RHD Models\)"](#) .

Name	Connector	Terminal	Voltage (Approx.)
Power supply	F103	10	Battery voltage
		19	Battery voltage

OK or NG

- OK >> GO TO 4.
NG >> GO TO 3.

3. DETECT MALFUNCTIONING ITEM

Check the following.

- Harness for short or open between ignition switch and TCM connector terminal 10, 19
Refer to [CVT-149, "Wiring Diagram — CVT — POWER \(LHD Models\)"](#) , [CVT-151, "Wiring Diagram — CVT — POWER \(RHD Models\)"](#) .
- 10A fuse (No.83, located in the IPDM E/R). Refer to [CVT-149, "Wiring Diagram — CVT — POWER \(LHD Models\)"](#) , [CVT-151, "Wiring Diagram — CVT — POWER \(RHD Models\)"](#) .
- Ignition switch. Refer to [PG-3, "POWER SUPPLY ROUTING CIRCUIT"](#) .

OK or NG

- OK >> GO TO 4.
NG >> Repair or replace damaged parts.

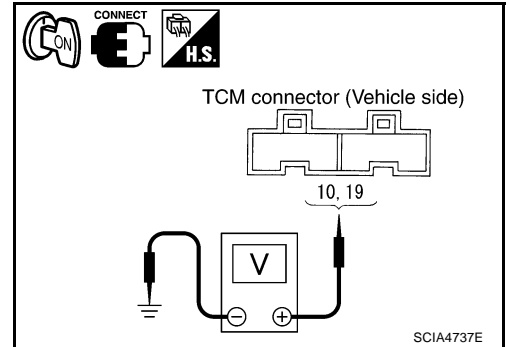

TROUBLE DIAGNOSIS FOR SYMPTOMS

4. CHECK TCM GROUND CIRCUIT

1. Turn ignition switch OFF.
2. Disconnect TCM connector.
3. Check continuity between TCM connector terminal and ground. Refer to [CVT-149, "Wiring Diagram — CVT — POWER \(LHD Models\)"](#), [CVT-151, "Wiring Diagram — CVT — POWER \(RHD Models\)"](#).

Name	Connector	Terminal	Continuity
Ground	F104	25	Yes
		48	

OK or NG

OK >> GO TO 5.

NG >> Repair open circuit or short to ground or short to power in harness or connectors.

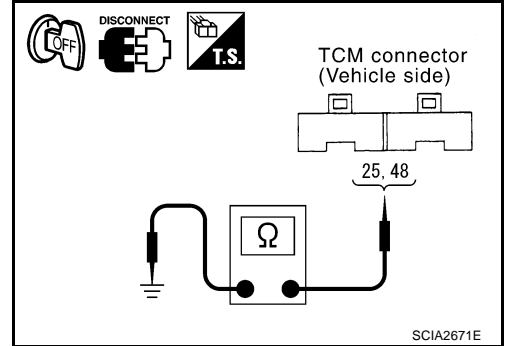

5. DETECT MALFUNCTIONING ITEM

Check the following.

- Harness and fuse for short or open between ignition switch and CVT indicator lamp. Refer to [PG-3, "POWER SUPPLY ROUTING CIRCUIT"](#).

OK or NG

OK >> GO TO 6.

NG >> Repair or replace damaged parts.

6. CHECK SYMPTOM

Check again. Refer to [CVT-44, "Check Before Engine Is Started"](#).

OK or NG

OK >> **INSPECTION END**

NG >> GO TO 7.

7. CHECK COMBINATION METERS

Check combination meters.

- Refer to [DI-4, "COMBINATION METERS"](#).

OK or NG

OK >> **INSPECTION END**

NG >> Repair or replace damaged parts.

TROUBLE DIAGNOSIS FOR SYMPTOMS

ECS00FC0

Engine Cannot Be Started in “P” or “N” Position

SYMPTOM:

- Engine cannot be started with selector lever in “P” or “N” position.
- Engine can be started with selector lever in “D”, “M” or “R” position.

DIAGNOSTIC PROCEDURE

1. CHECK SELF-DIAGNOSTIC RESULTS

Perform self-diagnosis check. Refer to [CVT-58, "SELF-DIAGNOSTIC RESULT MODE"](#) .

Do the self-diagnostic results indicate PNP switch circuit or start signal circuit?

- YES >> Check PNP switch circuit or start signal circuit. Refer to [CVT-74, "DTC P0705 PARK/NEUTRAL POSITION SWITCH"](#) or [CVT-68, "DTC P0615 START SIGNAL CIRCUIT"](#) .
- NO >> GO TO 2.

2. CHECK CONTROL CABLE

Check control cable. Refer to [CVT-205, "Checking of CVT Position"](#)

OK or NG

- OK >> GO TO 3.
- NG >> Adjust control cable. Refer to [CVT-204, "Adjustment of CVT Position"](#) .

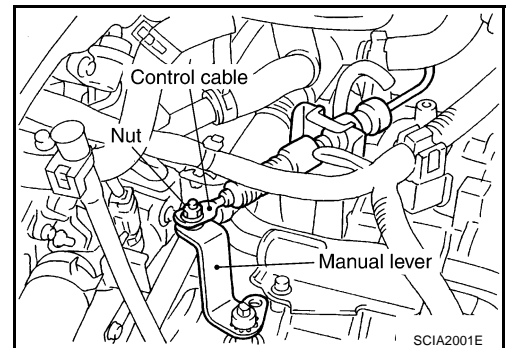

3. CHECK STARTING SYSTEM

Check starting system. Refer to [SC-13, "STARTING SYSTEM"](#) .

OK or NG

- OK >> **INSPECTION END**
- NG >> Repair or replace damaged parts.

TROUBLE DIAGNOSIS FOR SYMPTOMS

In "P" Position, Vehicle Moves Forward or Backward When Pushed SYMPTOM:

ECS00FC1

Vehicle moves when it is pushed forward or backward with selector lever in "P" position.

DIAGNOSTIC PROCEDURE

1. CHECK SELF-DIAGNOSTIC RESULTS

Perform self-diagnosis check. Refer to [CVT-58, "SELF-DIAGNOSTIC RESULT MODE"](#) .

Do the self-diagnostic results indicate PNP switch circuit?

- YES >> Check PNP switch circuit. Refer to [CVT-74, "DTC P0705 PARK/NEUTRAL POSITION SWITCH"](#) .
- NO >> GO TO 2.

2. CHECK CONTROL CABLE

Check control cable. Refer to [CVT-205, "Checking of CVT Position"](#)

OK or NG

- OK >> GO TO 3.
- NG >> Adjust control cable. Refer to [CVT-204, "Adjustment of CVT Position"](#) .

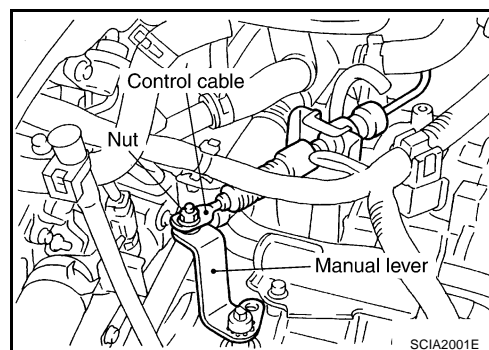

3. CHECK SYMPTOM

Check again. Refer to [CVT-44, "Check at Idle"](#) .

OK or NG

- OK >> **INSPECTION END**
- NG >> Replace the transaxle assembly. Refer to [CVT-226, "Removal and Installation"](#) .

TROUBLE DIAGNOSIS FOR SYMPTOMS

ECS00FC2

In "N" Position, Vehicle Moves

SYMPTOM:

Vehicle moves forward or backward when selecting "N" position.

DIAGNOSTIC PROCEDURE

1. CHECK SELF-DIAGNOSTIC RESULTS

Perform self-diagnosis check. Refer to [CVT-58, "SELF-DIAGNOSTIC RESULT MODE"](#) .

Do the self-diagnostic results indicate PNP switch circuit?

- YES >> Check PNP switch circuit. Refer to [CVT-74, "DTC P0705 PARK/NEUTRAL POSITION SWITCH"](#) .
- NO >> GO TO 2.

2. CHECK CONTROL CABLE

Check control cable. Refer to [CVT-205, "Checking of CVT Position"](#)

OK or NG

- OK >> GO TO 3.
- NG >> Adjust control cable. Refer to [CVT-204, "Adjustment of CVT Position"](#) .

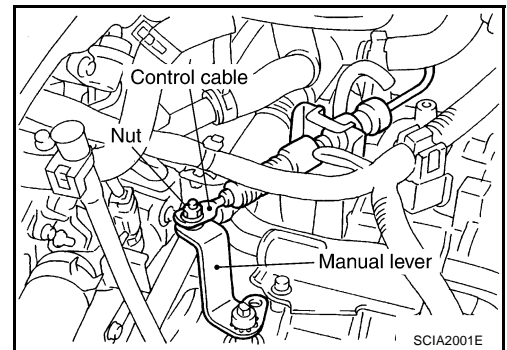

3. CHECK CVT FLUID LEVEL

Check CVT fluid level. Refer to [CVT-14, "Checking CVT Fluid"](#) .

OK or NG

- OK >> GO TO 4.
- NG >> Refill CVT fluid.

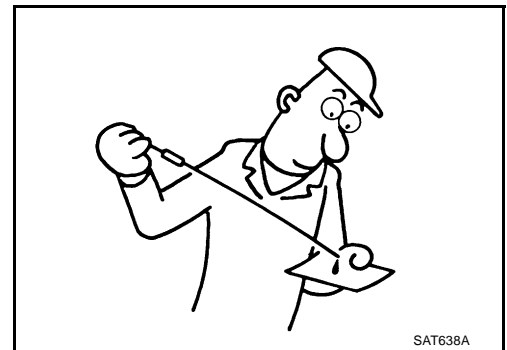

4. CHECK SYMPTOM

Check again. Refer to [CVT-44, "Check at Idle"](#) .

OK or NG

- OK >> **INSPECTION END**
- NG >> GO TO 5.

5. CHECK TCM

1. Check TCM input/output signal. Refer to [CVT-50, "TCM Input/Output Signal Reference Values"](#) .
2. If NG, re-check TCM pin terminals for damage or loose connection with harness connector.

OK or NG

- OK >> Replace the transaxle assembly. Refer to [CVT-226, "Removal and Installation"](#) .
- NG >> Repair or replace damaged parts.

TROUBLE DIAGNOSIS FOR SYMPTOMS

EC500FC3

Large Shock "N" → "R" Position

SYMPTOM:

There is large shock when shifting from "N" to "R" position.

DIAGNOSTIC PROCEDURE

1. CHECK SELF-DIAGNOSTIC RESULTS

Perform self-diagnosis check. Refer to [CVT-58, "SELF-DIAGNOSTIC RESULT MODE"](#) .

Is any malfunction detected by self-diagnosis?

- YES >> Check the malfunctioning system.
- NO >> GO TO 2.

2. CHECK ENGINE IDLE SPEED

Check engine idle speed. Refer to [EC-61, "Idle Speed and Ignition Timing Check"](#) .

OK or NG

- OK >> GO TO 3.
- NG >> Repair.

3. CHECK CVT FLUID LEVEL

Check CVT fluid level. Refer to [CVT-14, "Checking CVT Fluid"](#) .

OK or NG

- OK >> GO TO 4.
- NG >> Refill CVT fluid.

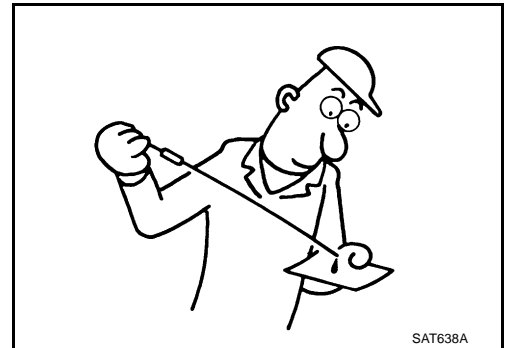

4. CHECK LINE PRESSURE

Check line pressure at idle. Refer to [CVT-39, "LINE PRESSURE TEST"](#) .

OK or NG

- OK >> GO TO 5.
- NG >> Check the malfunctioning item. Refer to [CVT-40, "Judgement of Line Pressure Test"](#) .

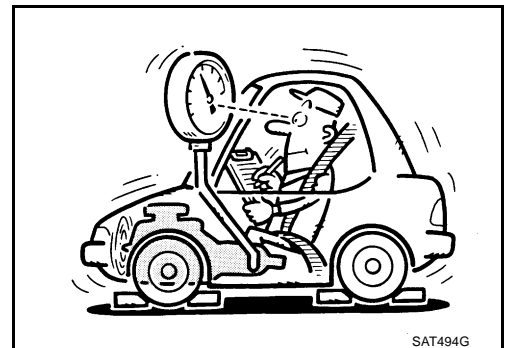

5. CHECK SYMPTOM

Check again. Refer to [CVT-44, "Check at Idle"](#) .

OK or NG

- OK >> **INSPECTION END**
- NG >> GO TO 6.

A

B

CVT

D

E

F

G

H

I

J

K

L

M

TROUBLE DIAGNOSIS FOR SYMPTOMS

6. CHECK TCM

1. Check TCM input/output signals. Refer to [CVT-50, "TCM Input/Output Signal Reference Values"](#) .
2. If NG, re-check TCM pin terminals for damage or loose connection with harness connector.

OK or NG

- OK >> Replace the transaxle assembly. Refer to [CVT-226, "Removal and Installation"](#) .
- NG >> Repair or replace damaged parts.

TROUBLE DIAGNOSIS FOR SYMPTOMS

EC500FC4

Vehicle Does Not Creep Backward in "R" Position SYMPTOM:

Vehicle does not creep backward when selecting "R" position.

DIAGNOSTIC PROCEDURE

1. CHECK SELF-DIAGNOSTIC RESULTS

Perform self-diagnosis check. Refer to [CVT-58, "SELF-DIAGNOSTIC RESULT MODE"](#).

Is any malfunction detected by self-diagnosis?

- YES >> Check the malfunctioning system.
- NO >> GO TO 2.

2. CHECK CONTROL CABLE

Check control cable. Refer to [CVT-205, "Checking of CVT Position"](#)

OK or NG

- OK >> GO TO 3.
- NG >> Adjust control cable. Refer to [CVT-204, "Adjustment of CVT Position"](#).

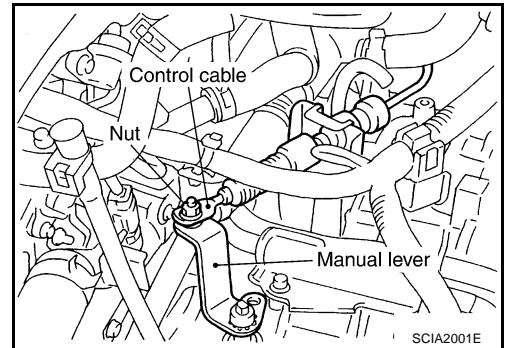

3. CHECK CVT FLUID LEVEL

Check CVT fluid level. Refer to [CVT-14, "Checking CVT Fluid"](#).

OK or NG

- OK >> GO TO 4.
- NG >> Refill CVT fluid.

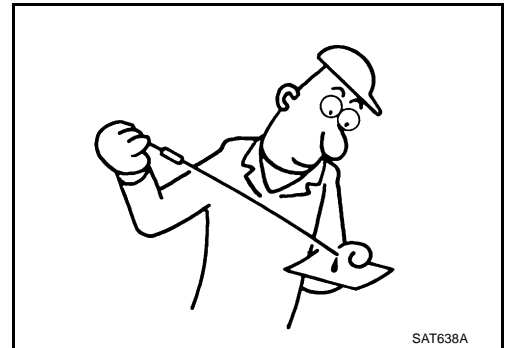

4. CHECK LINE PRESSURE

Check line pressure at idle. Refer to [CVT-39, "LINE PRESSURE TEST"](#).

OK or NG

- OK >> GO TO 5.
- NG >> Check the malfunctioning item. Refer to [CVT-40, "Judgement of Line Pressure Test"](#).

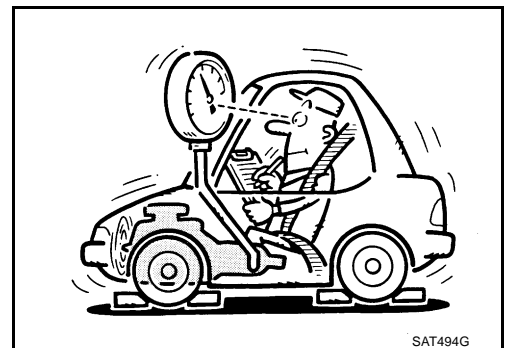

TROUBLE DIAGNOSIS FOR SYMPTOMS

5. CHECK SYMPTOM

Check again. Refer to [CVT-44, "Check at Idle"](#) .

OK or NG

OK >> **INSPECTION END**
NG >> GO TO 6.

6. CHECK TCM

1. Check TCM input/output signals. Refer to [CVT-50, "TCM Input/Output Signal Reference Values"](#) .
2. If NG, re-check TCM pin terminals for damage or loose connection with harness connector.

OK or NG

OK >> Replace the transaxle assembly. Refer to [CVT-226, "Removal and Installation"](#) .
NG >> Repair or replace damaged parts.

TROUBLE DIAGNOSIS FOR SYMPTOMS

EC500FC5

Vehicle Does Not Creep Forward in "D" Position SYMPTOM:

Vehicle does not creep forward when selecting "D" position.

DIAGNOSTIC PROCEDURE

1. CHECK SELF-DIAGNOSTIC RESULTS

Perform self-diagnosis check. Refer to [CVT-58, "SELF-DIAGNOSTIC RESULT MODE"](#) .

Is any malfunction detected by self-diagnosis?

- YES >> Check the malfunctioning system.
- NO >> GO TO 2.

2. CHECK CONTROL CABLE

Check control cable. Refer to [CVT-205, "Checking of CVT Position"](#)

OK or NG

- OK >> GO TO 3.
- NG >> Adjust control cable. Refer to [CVT-204, "Adjustment of CVT Position"](#) .

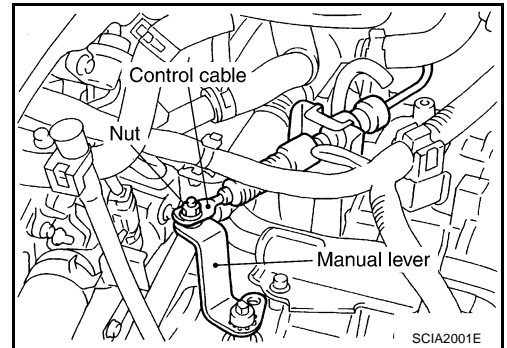

3. CHECK CVT FLUID LEVEL

Check CVT fluid level. Refer to [CVT-14, "Checking CVT Fluid"](#) .

OK or NG

- OK >> GO TO 4.
- NG >> Refill CVT fluid.

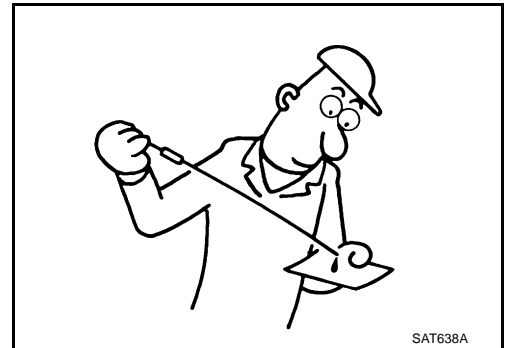

4. CHECK LINE PRESSURE

Check line pressure at idle. Refer to [CVT-39, "LINE PRESSURE TEST"](#) .

OK or NG

- OK >> GO TO 5.
- NG >> Check the malfunctioning item. Refer to [CVT-40, "Judgement of Line Pressure Test"](#) .

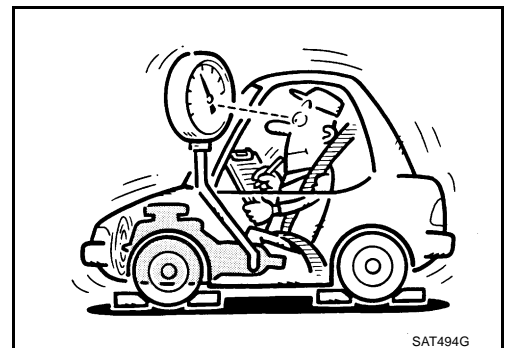

A
B
CVT
D
E
F
G
H
I
J
K
L
M

TROUBLE DIAGNOSIS FOR SYMPTOMS

5. CHECK SYMPTOM

Check again. Refer to [CVT-44, "Check at Idle"](#) .

OK or NG

OK >> **INSPECTION END**
NG >> GO TO 6.

6. CHECK TCM

1. Check TCM input/output signals. Refer to [CVT-50, "TCM Input/Output Signal Reference Values"](#) .
2. If NG, re-check TCM pin terminals for damage or loose connection with harness connector.

OK or NG

OK >> Replace the transaxle assembly. Refer to [CVT-226, "Removal and Installation"](#) .
NG >> Repair or replace damaged parts.

TROUBLE DIAGNOSIS FOR SYMPTOMS

EC500FC6

CVT Does Not Shift

SYMPTOM:

CVT does not shift at the specified speed on "Cruise Test".

DIAGNOSTIC PROCEDURE

1. CHECK SELF-DIAGNOSTIC RESULTS

Perform self-diagnosis check. Refer to [CVT-58, "SELF-DIAGNOSTIC RESULT MODE"](#).

Is any malfunction detected by self-diagnosis?

- YES >> Check the malfunctioning system.
- NO >> GO TO 2.

2. CHECK CONTROL CABLE

Check control cable. Refer to [CVT-205, "Checking of CVT Position"](#)

OK or NG

- OK >> GO TO 3.
- NG >> Adjust control cable. Refer to [CVT-204, "Adjustment of CVT Position"](#).

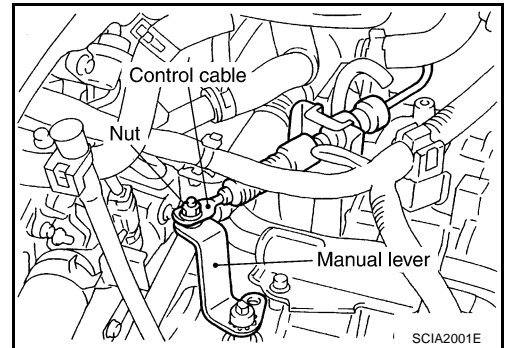

3. CHECK CVT FLUID LEVEL

Check CVT fluid level. Refer to [CVT-14, "Checking CVT Fluid"](#).

OK or NG

- OK >> GO TO 4.
- NG >> Refill CVT fluid.

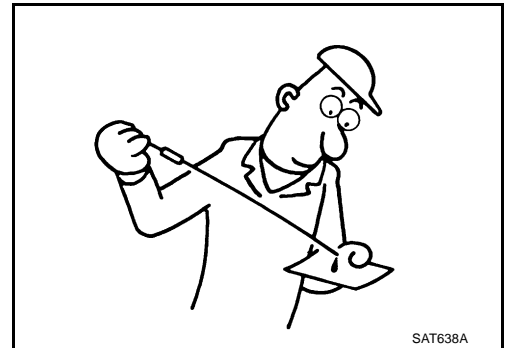

4. CHECK LINE PRESSURE

Check line pressure at idle. Refer to [CVT-39, "LINE PRESSURE TEST"](#).

OK or NG

- OK >> GO TO 5.
- NG >> Check the malfunctioning item. Refer to [CVT-40, "Judgement of Line Pressure Test"](#).

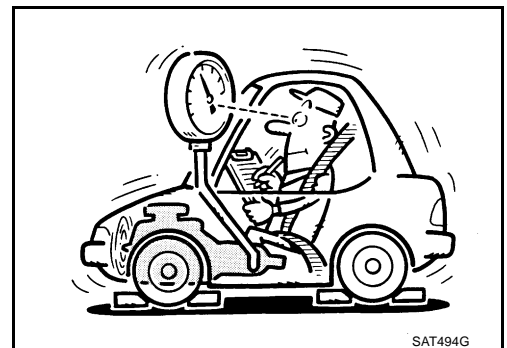

TROUBLE DIAGNOSIS FOR SYMPTOMS

5. CHECK SYMPTOM

Check again. Refer to [CVT-47, "Cruise Test"](#) .

OK or NG

OK >> **INSPECTION END**
NG >> GO TO 6.

6. CHECK TCM

1. Check TCM input/output signals. Refer to [CVT-50, "TCM Input/Output Signal Reference Values"](#) .
2. If NG, re-check TCM pin terminals for damage or loose connection with harness connector.

OK or NG

OK >> Replace the transaxle assembly. Refer to [CVT-226, "Removal and Installation"](#) .
NG >> Repair or replace damaged parts.

TROUBLE DIAGNOSIS FOR SYMPTOMS

EC500FC7

Cannot Be Changed to Manual Mode

SYMPTOM:

Does not change to manual mode when manual shift gate is used.

DIAGNOSTIC PROCEDURE

1. CHECK SELF-DIAGNOSTIC RESULTS

Perform self-diagnosis check. Refer to [CVT-58, "SELF-DIAGNOSTIC RESULT MODE"](#) .

Is any malfunction detected by self-diagnosis?

YES >> Check the malfunctioning system.

NO >> GO TO 2.

2. CHECK MANUAL MODE SWITCH

Check manual mode switch circuit. Refer to [CVT-125, "DTC P0826 MANUAL MODE SWITCH CIRCUIT"](#) .

OK or NG

OK >> GO TO 3.

NG >> Repair or replace damaged parts.

3. CHECK SYMPTOM

Check again. Refer to [CVT-47, "Cruise Test"](#) .

OK or NG

OK >> **INSPECTION END**

NG >> GO TO 4.

4. CHECK TCM

1. Check TCM input/output signal. Refer to [CVT-50, "TCM Input/Output Signal Reference Values"](#) .

2. If NG, re-check TCM pin terminals for damage or loose connection with harness connector.

OK or NG

OK >> **INSPECTION END**

NG >> Repair or replace damaged parts.

A

B

CVT

D

E

F

G

H

I

J

K

L

M

TROUBLE DIAGNOSIS FOR SYMPTOMS

ECS00FC8

CVT Does Not Shift in Manual Mode

SYMPTOM:

Speed does not change even if the selector lever is put in the manual shift gate position and the selector lever is operated to + side or to - side.

DIAGNOSTIC PROCEDURE

1. CHECK SELF-DIAGNOSTIC RESULTS

Perform self-diagnosis check. Refer to [CVT-58, "SELF-DIAGNOSTIC RESULT MODE"](#) .

Is any malfunction detected by self-diagnosis?

YES >> Check the malfunctioning system.

NO >> GO TO 2.

2. CHECK MANUAL MODE SWITCH

Check manual mode switch circuit. Refer to [CVT-125, "DTC P0826 MANUAL MODE SWITCH CIRCUIT"](#) .

OK or NG

OK >> GO TO 3.

NG >> Repair or replace damaged parts.

3. CHECK CONTROL CABLE

Check control cable. Refer to [CVT-205, "Checking of CVT Position"](#)

OK or NG

OK >> GO TO 4.

NG >> Adjust control cable. Refer to [CVT-204, "Adjustment of CVT Position"](#) .

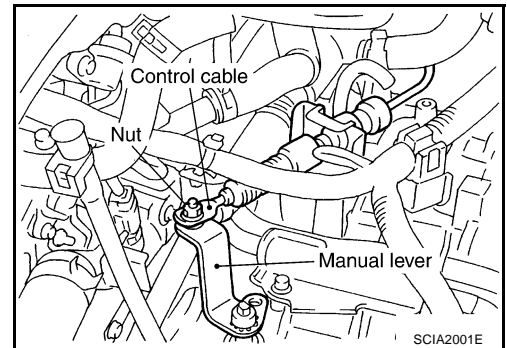

4. CHECK CVT FLUID LEVEL

Check CVT fluid level. Refer to [CVT-14, "Checking CVT Fluid"](#) .

OK or NG

OK >> GO TO 5.

NG >> Refill CVT fluid.

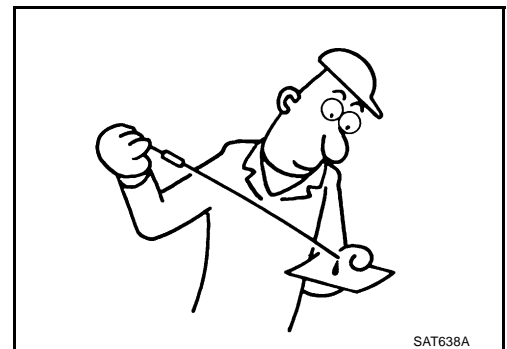

TROUBLE DIAGNOSIS FOR SYMPTOMS

5. CHECK LINE PRESSURE

Check line pressure at idle. Refer to [CVT-39, "LINE PRESSURE TEST"](#).

OK or NG

OK >> GO TO 6.

NG >> Check the malfunctioning item. Refer to [CVT-40, "Judgement of Line Pressure Test"](#).

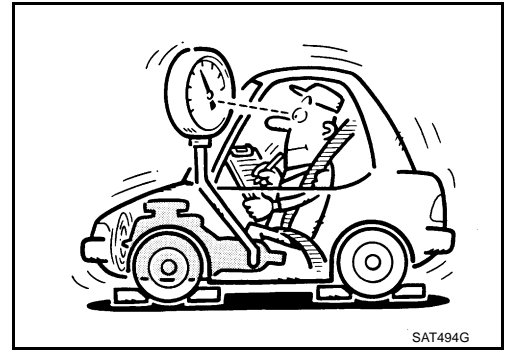

6. CHECK SYMPTOM

Check again. Refer to [CVT-47, "Cruise Test"](#).

OK or NG

OK >> **INSPECTION END**

NG >> GO TO 7.

7. CHECK TCM

1. Check TCM input/output signals. Refer to [CVT-50, "TCM Input/Output Signal Reference Values"](#).

2. If NG, re-check TCM pin terminals for damage or loose connection with harness connector.

OK or NG

OK >> Replace the transaxle assembly. Refer to [CVT-226, "Removal and Installation"](#).

NG >> Repair or replace damaged parts.

A
B
CVT
D
E
F
G
H
I
J
K
L
M

TROUBLE DIAGNOSIS FOR SYMPTOMS

ECS00FCB

Vehicle Does Not Decelerate by Engine Brake

SYMPTOM:

No engine brake is applied when the gear is shifted from the "M2" to "M1" position.

DIAGNOSTIC PROCEDURE

1. CHECK SELF-DIAGNOSTIC RESULTS

Perform self-diagnosis check. Refer to [CVT-58, "SELF-DIAGNOSTIC RESULT MODE"](#) .

Is any malfunction detected by self-diagnosis?

- YES >> Check the malfunctioning system.
- NO >> GO TO 2.

2. CHECK CONTROL CABLE

Check control cable. Refer to [CVT-205, "Checking of CVT Position"](#)

OK or NG

- OK >> GO TO 3.
- NG >> Adjust control cable. Refer to [CVT-204, "Adjustment of CVT Position"](#) .

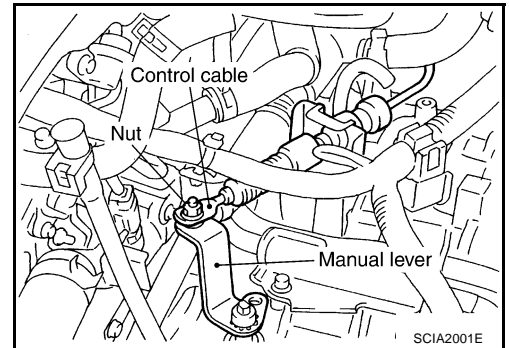

3. CHECK CVT FLUID LEVEL

Check CVT fluid level. Refer to [CVT-14, "Checking CVT Fluid"](#) .

OK or NG

- OK >> GO TO 4.
- NG >> Refill CVT fluid.

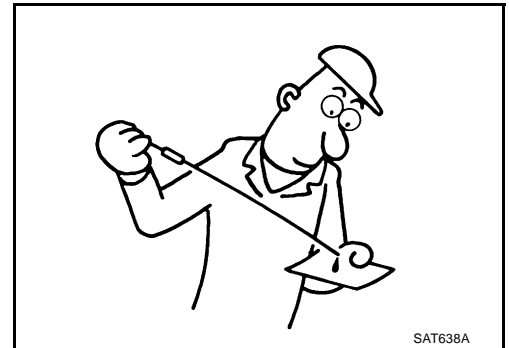

4. CHECK LINE PRESSURE

Check line pressure at idle. Refer to [CVT-39, "LINE PRESSURE TEST"](#) .

OK or NG

- OK >> GO TO 5.
- NG >> Check the malfunctioning item. Refer to [CVT-40, "Judgement of Line Pressure Test"](#) .

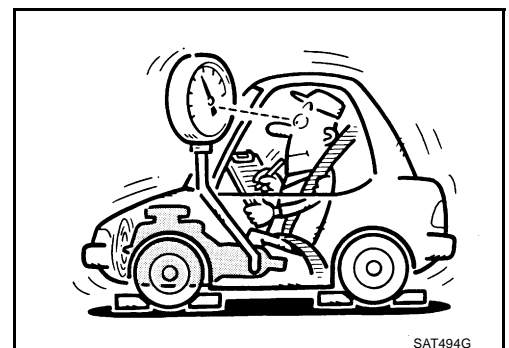

TROUBLE DIAGNOSIS FOR SYMPTOMS

5. CHECK MANUAL MODE SWITCH

Check manual mode switch circuit. Refer to [CVT-125, "DTC P0826 MANUAL MODE SWITCH CIRCUIT"](#) .
OK or NG

- OK >> GO TO 6.
- NG >> Repair or replace damaged parts.

6. CHECK SYMPTOM

Check again. Refer to [CVT-47, "Cruise Test"](#) .
OK or NG

- OK >> **INSPECTION END**
- NG >> GO TO 7.

7. CHECK TCM

1. Check TCM input/output signals. Refer to [CVT-50, "TCM Input/Output Signal Reference Values"](#) .
2. If NG, re-check TCM pin terminals for damage or loose connection with harness connector.

OK or NG

- OK >> Replace the transaxle assembly. Refer to [CVT-226, "Removal and Installation"](#) .
- NG >> Repair or replace damaged parts.

A

B

CVT

D

E

F

G

H

I

J

K

L

M

SHIFT CONTROL SYSTEM

SHIFT CONTROL SYSTEM

PFP:34901

Removal and Installation CONTROL DEVICE COMPONENTS

ECS00FCC

SEC. 349

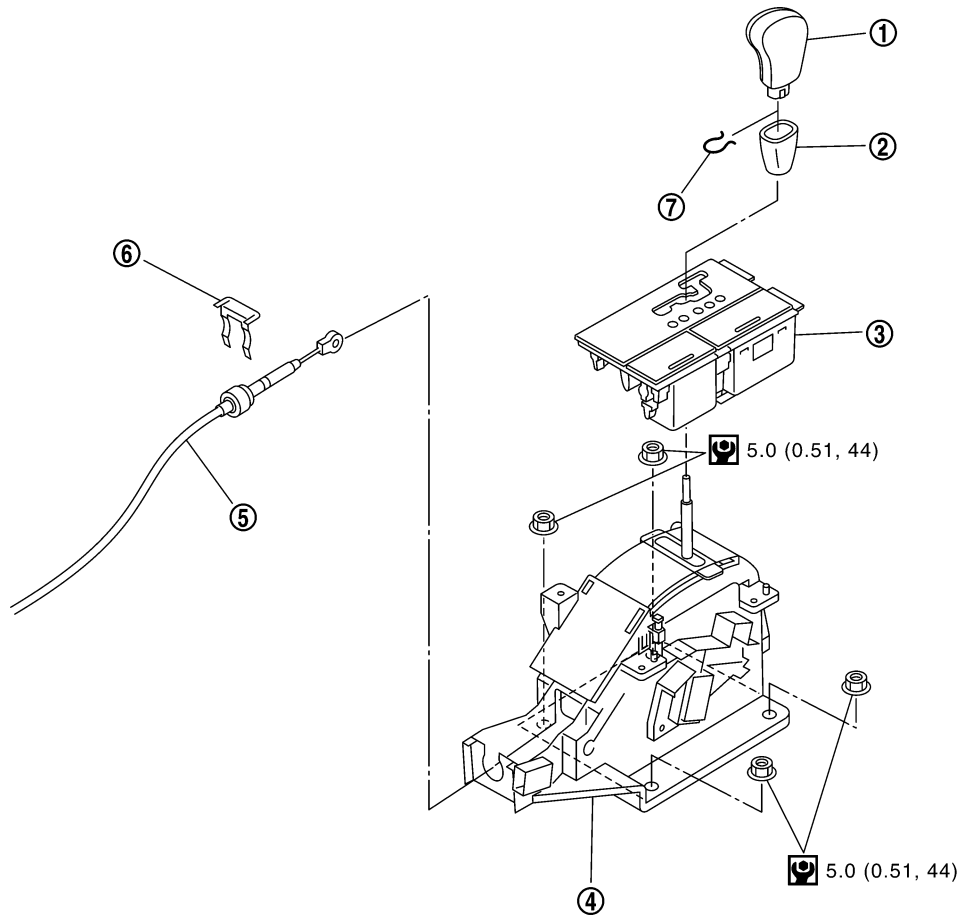

 : N·m (kg-m, in-lb)

SCIA6463E

- | | | |
|----------------------------|------------------|-------------------------|
| 1. Selector lever knob | 2. Knob cover | 3. A/T console finisher |
| 4. Control device assembly | 5. Control cable | 6. Lock plate |
| 7. Lock pin | | |

SHIFT CONTROL SYSTEM

CONTROL CABLE COMPONENTS

Refer to the figure below for control cable removal and installation procedure.

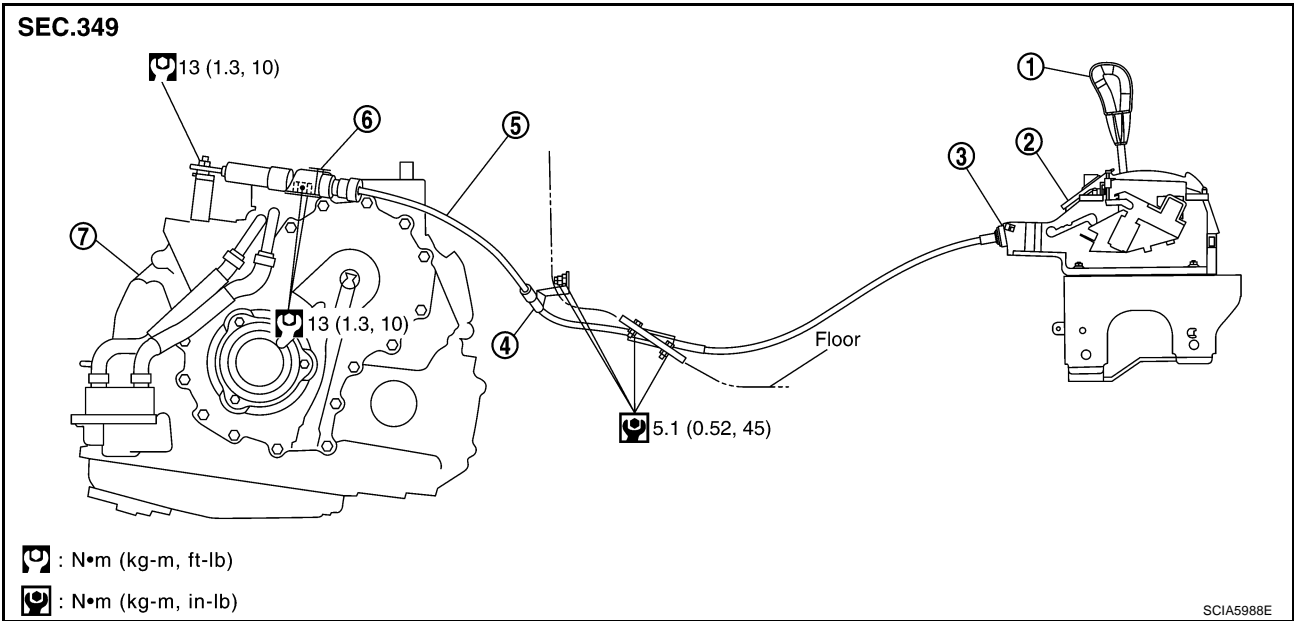

- | | | |
|------------------------|----------------------------|---------------|
| 1. Selector lever knob | 2. Control device assembly | 3. Lock plate |
| 4. Bracket | 5. Control cable | 6. Lock plate |
| 7. Transaxle assembly | | |

REMOVAL

- Remove knob cover below selector lever downward.
- Pull lock pin out of selector lever knob.
- Remove selector lever knob.
- Remove A/T console finisher.
 - Refer to [IP-17, "Removal and Installation"](#).
- Remove console box assembly.
 - Refer to [IP-17, "Removal and Installation"](#).
- Disconnect control cable of control device.
- Disconnect control device harness connector.

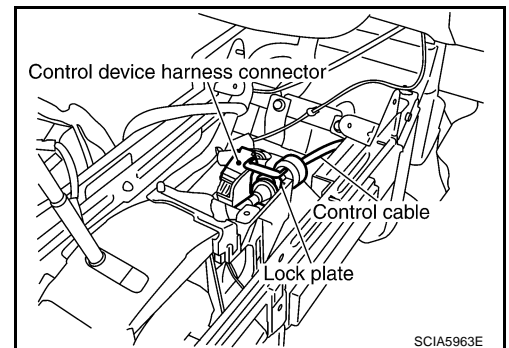
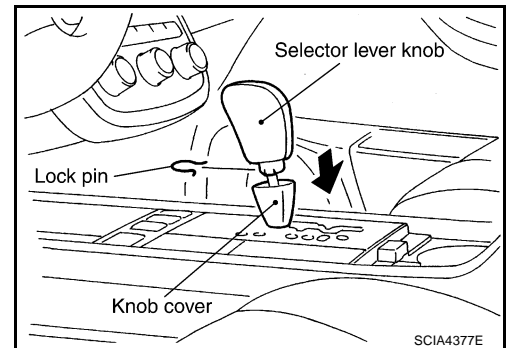

SHIFT CONTROL SYSTEM

8. Remove control device assembly.

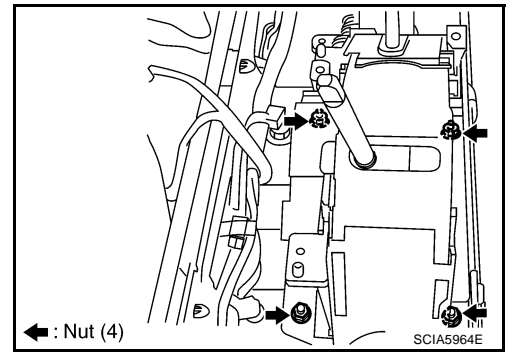

INSTALLATION

Note the following, and install in the reverse order of removal.

- The knurled surface of rib should be upward when installing the control cable to the control device assembly. And insert the control cable securely.
- After installation is completed, adjust and check CVT position. Refer to [CVT-204, "Adjustment of CVT Position"](#) and [CVT-205, "Checking of CVT Position"](#).

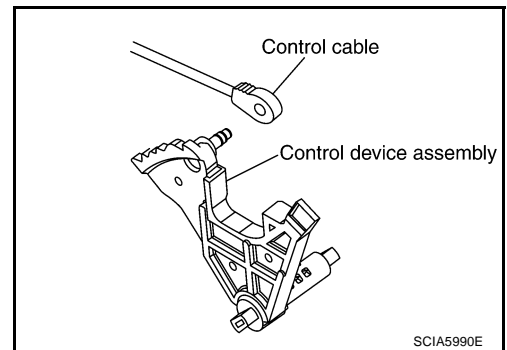

Adjustment of CVT Position

1. Place selector lever in "P" position.
2. Loosen control cable nut and place manual lever in "P" position.

CAUTION:

Turn wheels more than 1/4 rotations and apply the park lock.

3. Hold the control cable at the end. Push and pull it twice or three times, and then push it with a load of 9.8N (approximately 1 kg, 2.2 lb). Temporarily tighten the lock nut with the control cable loose.
4. Connect control cable on manual lever.

CAUTION:

No application of a force to the manual lever.

5. Tighten control cable nut.

CAUTION:

Fix the manual lever when tightening.

 : 13 N·m (1.3 kg·m, 10 ft·lb)

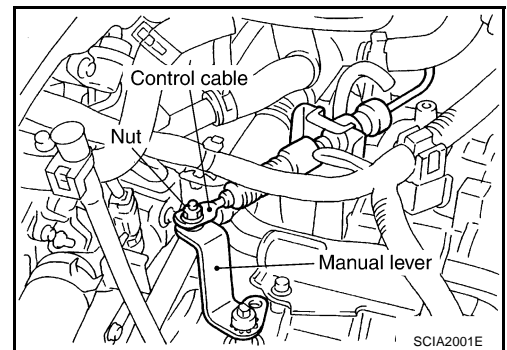

SHIFT CONTROL SYSTEM

Checking of CVT Position

ECS00FCE

1. Place selector lever in "P" position, and turn ignition switch ON (engine stop).
2. Make sure selector lever can be shifted to other than "P" position when brake pedal is depressed. Also make sure selector lever can be shifted from "P" position only when brake pedal is depressed.
3. Move the selector lever and check for excessive effort, sticking, noise or rattle.
4. Confirm the selector lever stops at each position with the feel of engagement when it is moved through all the positions. Check whether or not the actual position the selector lever is in matches the position shown by the shift position indicator and the transaxle body.
5. The method of operating the lever to individual positions correctly should be as shown in the figure.
6. Confirm the back-up lamps illuminate only when lever is placed in the "R" position. Confirm the back-up lamps do not illuminate when the selector lever is pushed toward the "R" position side with the gear position remained in the "P" or "N" position.
7. Confirm the engine can only be started with the selector lever in the "P" and "N" positions.
8. Make sure transaxle is locked completely in "P" position.
9. When selector lever is set to manual shift gate, make sure manual mode is displayed on combination meter.
Shift selector lever to "+" and "-" sides, and make sure set shift position changes.

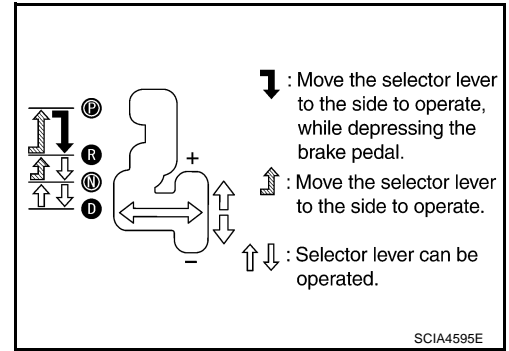

A

B

CVT

D

E

F

G

H

I

J

K

L

M

CVT SHIFT LOCK SYSTEM

CVT SHIFT LOCK SYSTEM

PFP:00000

Description

ECS00FCF

- The electrical key interlock mechanism also operates as a shift lock:
With the ignition switch turned to ON, the selector lever cannot be shifted from "P" (parking) to any other position unless the brake pedal is depressed.
With the key removed, the selector lever cannot be shifted from "P" to any other position.
The key cannot be removed unless the selector lever is placed in "P".
- The shift lock and key interlock mechanisms are controlled by the ON-OFF operation of the shift lock solenoid and by the operation of the rotator and slider located inside the key cylinder, respectively.

Shift Lock System Electrical Parts Location

ECS00FCG

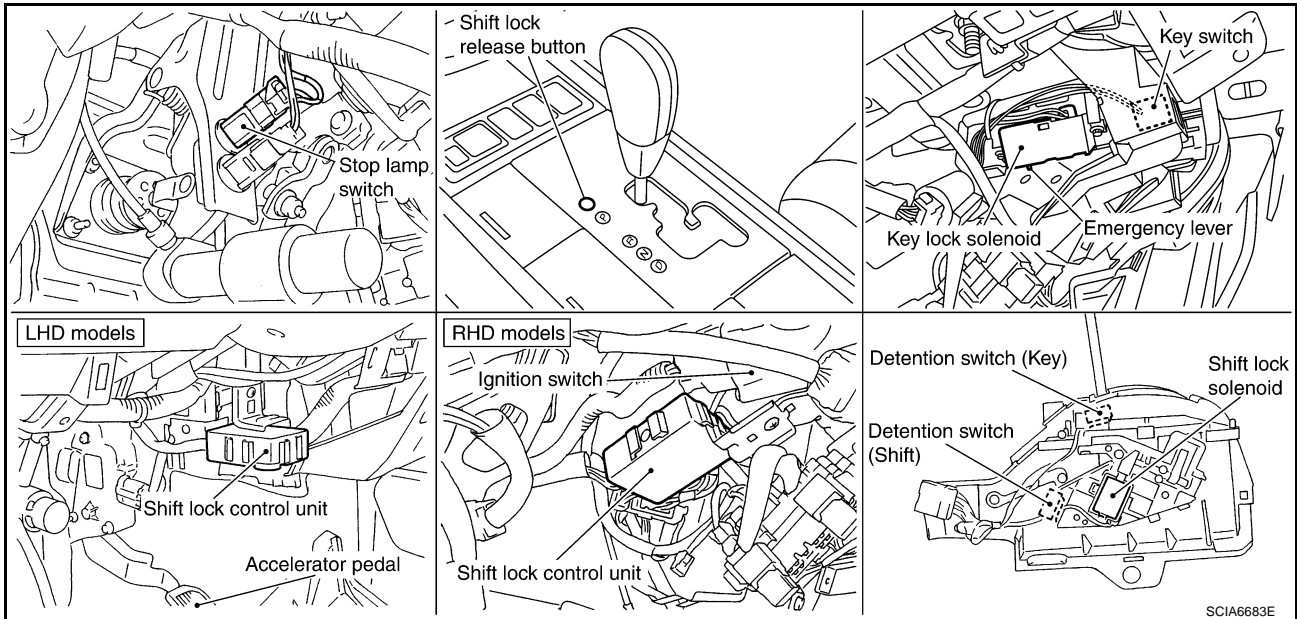

NOTE:

This emergency lever can be used when battery is off ignition key cannot be removed. In the situation like this, by operating this lever, ignition key can be removed.

CVT SHIFT LOCK SYSTEM

Wiring Diagram — CVT — SHIFT (LHD Models)

ECS00FCH

CVT-SHIFT-01

A
B
C
D
E
F
G
H
I
J
K
L
M

CVT

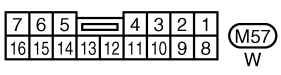
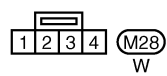
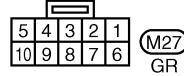
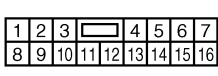
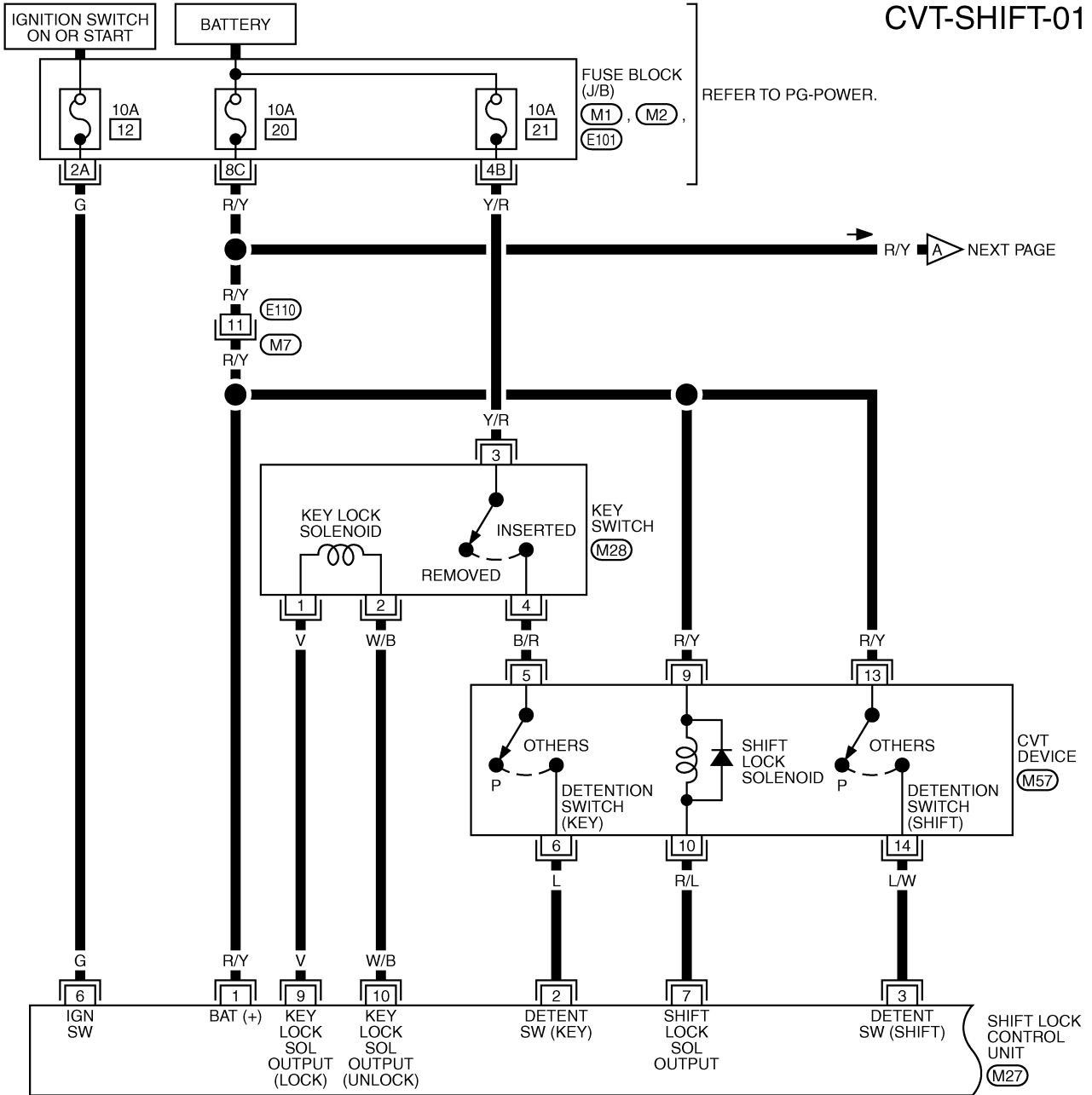

REFER TO THE FOLLOWING.
(M1), (M2), (E101) - FUSE BLOCK-JUNCTION BOX (J/B)

TCWB0151E

CVT SHIFT LOCK SYSTEM

CVT-SHIFT-02

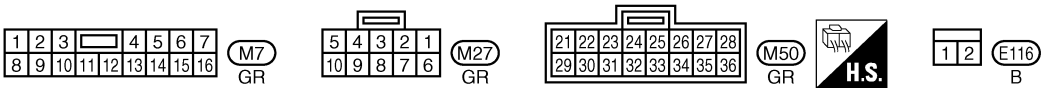
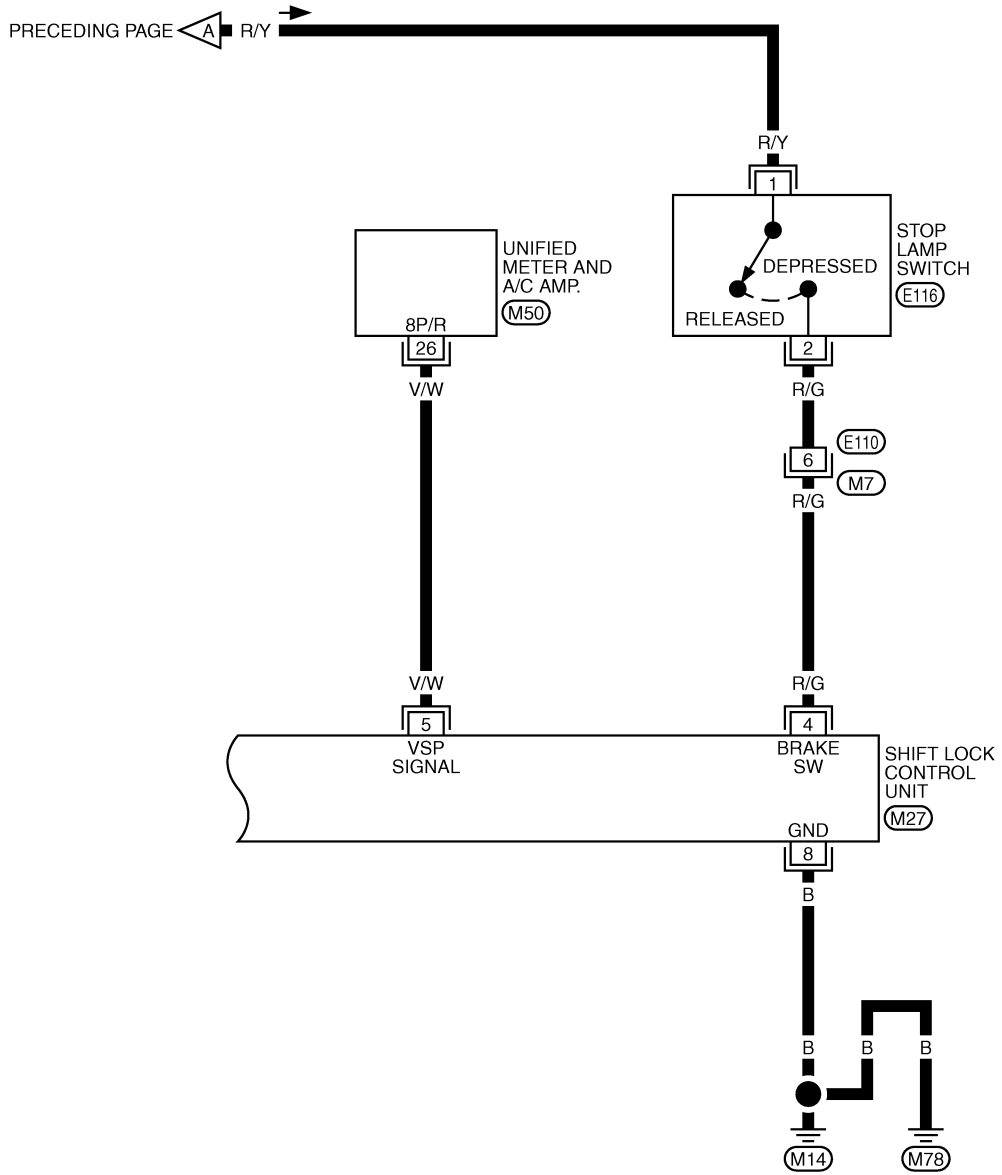

TCWA0166E

CVT SHIFT LOCK SYSTEM

Wiring Diagram — CVT — SHIFT (RHD Models)

ECS00FC1

CVT-SHIFT-03

A
B
CVT
D
E
F
G
H
I
J
K
L
M

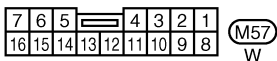
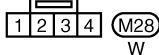
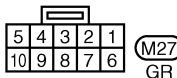
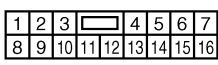
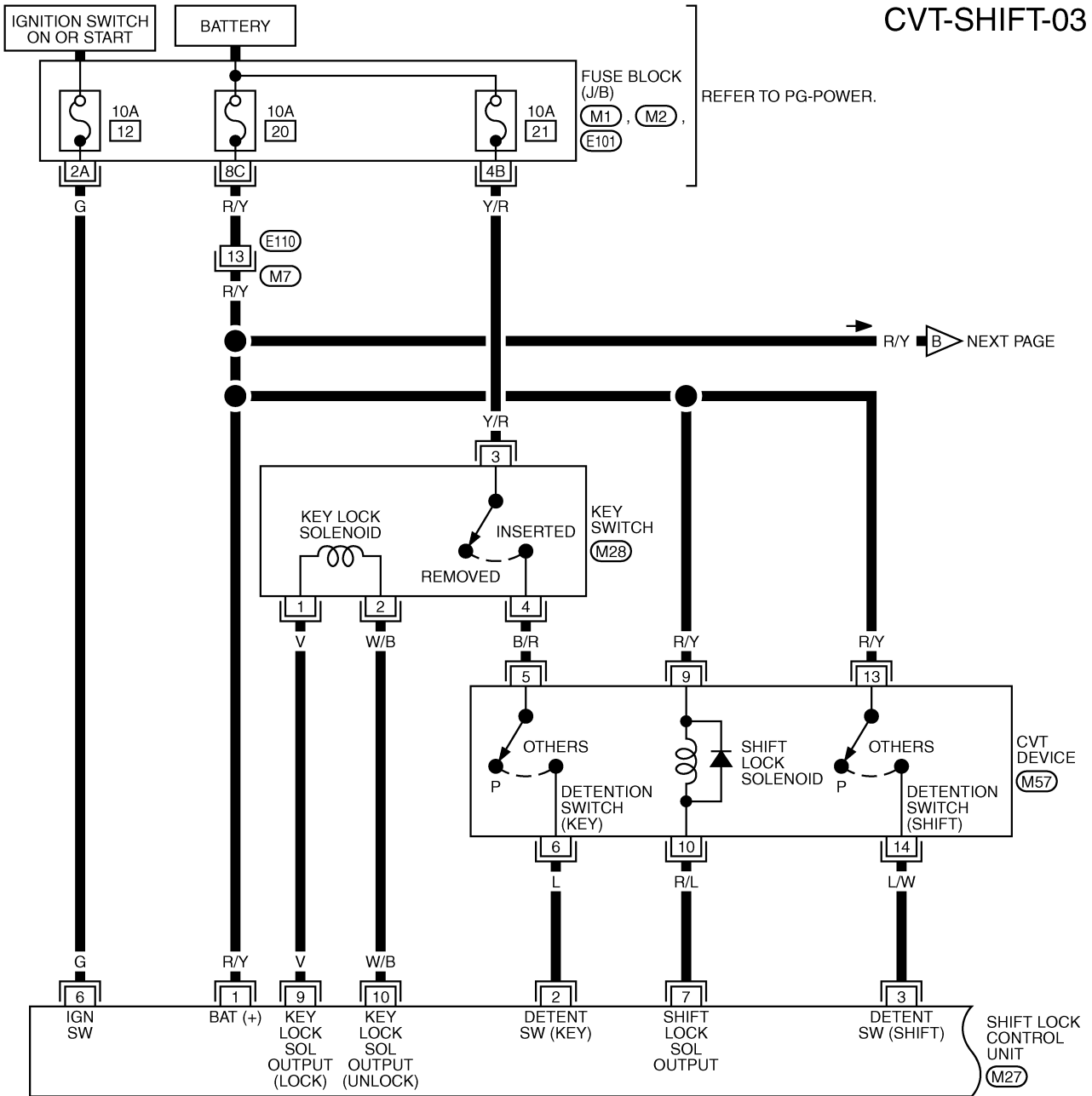

REFER TO THE FOLLOWING.
(M1), (M2), (E101) - FUSE BLOCK-JUNCTION BOX (J/B)

TCWB0152E

CVT SHIFT LOCK SYSTEM

CVT-SHIFT-04

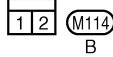
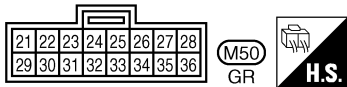
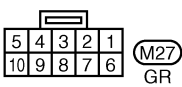
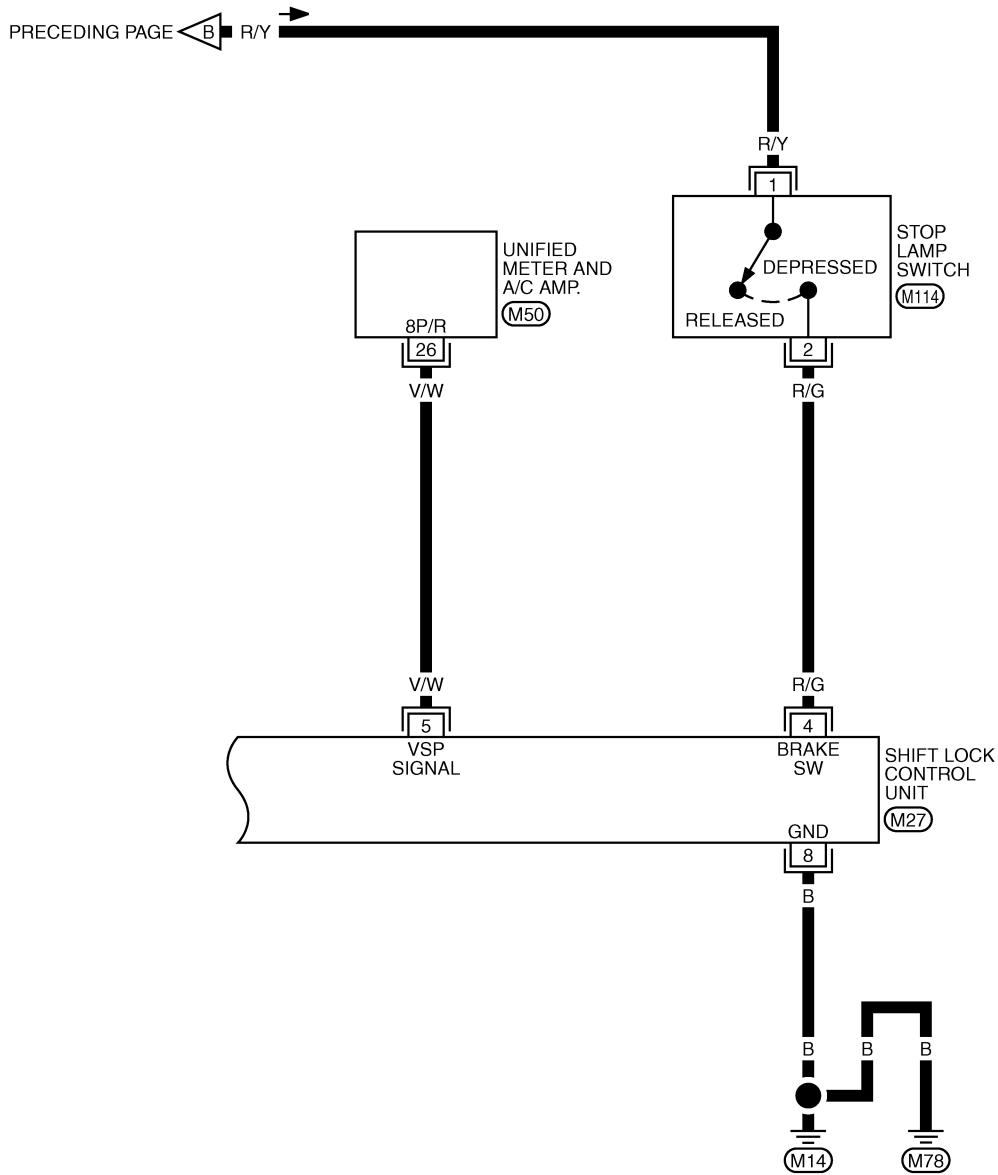

TCWB0153E

CVT SHIFT LOCK SYSTEM

Shift Lock Control Unit Reference Values SHIFT LOCK HARNESS CONNECTOR TERMINALS LAYOUT

EC500FCJ

A
B
CVT

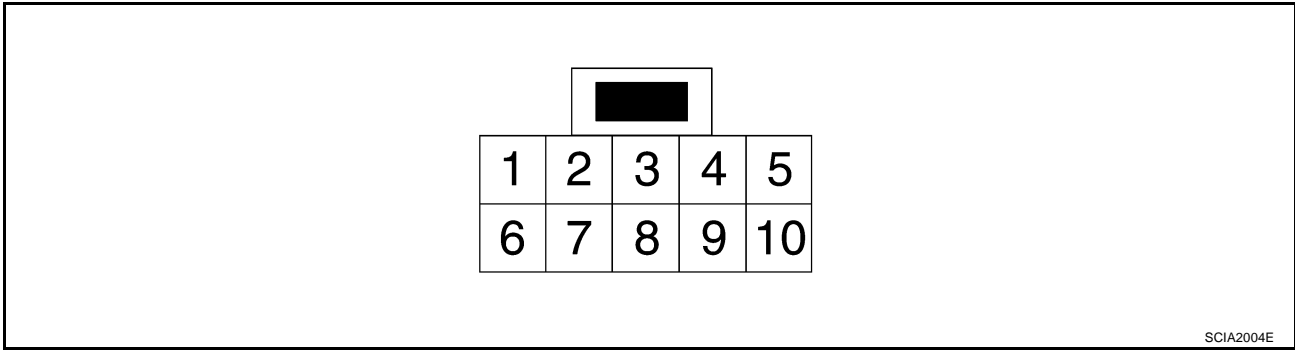

SHIFT LOCK CONTROL UNIT INSPECTION TABLE

Shift lock control unit terminal data are reference values, measured between each terminal and ground.

Terminal (Wire color)	Item	Condition	Judgement standard
1 (R/Y)	Power source	Always	Battery voltage
2 (L)	Detention switch (for key)	When selector lever is not in "P" position with key inserted or ignition knob switch pushed.	Battery voltage
		When selector lever is in "P" position with key inserted.	Approx. 0V
3 (L/W)	Detention switch (for shift)	When selector lever is not in "P" position.	Battery voltage
		When selector lever is in "P" position.	Approx. 0V
4 (R/G)	Stop lamp switch	When brake pedal is depressed	Battery voltage
		When brake pedal is released	Approx. 0V
5 (V/W)	Vehicle speed signal (8pulse signal)	Speed meter is operated	
6 (G)	Ignition signal	Ignition switch: OFF	Approx. 0V
		Ignition switch: ON	Battery voltage
7 (R/L)	Shift lock solenoid	<ul style="list-style-type: none"> When selector lever is in "P" position, brake pedal is depressed, and ignition switch is ON. When selector lever is not in "P" position, ignition switch is ON, and vehicle speed is 10 km/h (6 MPH) or less. For 3 minutes after selector lever is not in "P" position, vehicle speed is 10 km/h (6 MPH) or less, and ignition switch is ON → OFF. 	Approx. 0V
		Except the above	Battery voltage
8 (B)	Ground	—	Approx. 0V
9 (V)	Key lock solenoid	When selector lever is not "P" position.	Battery voltage for approx. 0.1 sec. (Note)
		When selector lever is in "P" position.	Approx. 0V
10 (W/B)	Key unlock solenoid	When selector lever is in "P" position with ignition switch OFF.	Battery voltage for approx. 0.1 sec. (Note)
		When selector lever is not in "P" position with ignition switch OFF.	Approx. 0V

D
E
F
G
H
I
J
K
L
M

CVT SHIFT LOCK SYSTEM

NOTE:

Take care that the pointer swings only momentarily because the output time is so short. If the inspection is done with an oscilloscope, it should be observed that the power source voltage lasts for 3.5 to 10 ms.

Component Inspection SHIFT LOCK SOLENOID

ECS00FCX

- Check operation by applying battery voltage to the CVT device harness connector.

CAUTION:

Be sure to apply the voltage of the correct polarity to the respective terminals. Otherwise, the part may be damaged.

Connector	Terminal
M57	9 (Battery voltage) - 10 (Ground)

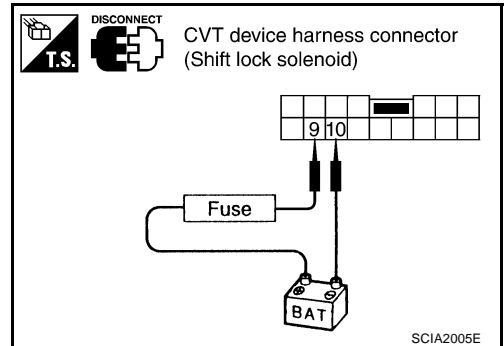

DETENTION SWITCH

For Key:

- Check continuity between terminals of the CVT device harness connector.

Condition	Connector	Terminal	Continuity
When selector lever is in "P" position.	M57	5 - 6	No
When selector lever is not in "P" position.			Yes

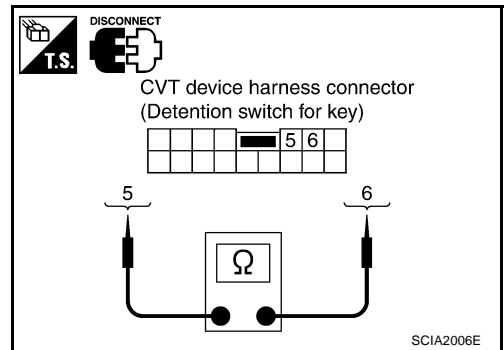

DETENTION SWITCH

For Shift:

- Check continuity between terminals of the CVT device harness connector.

Condition	Connector	Terminal	Continuity
When selector lever is in "P" position.	M57	13 - 14	No
When selector lever is not in "P" position.			Yes

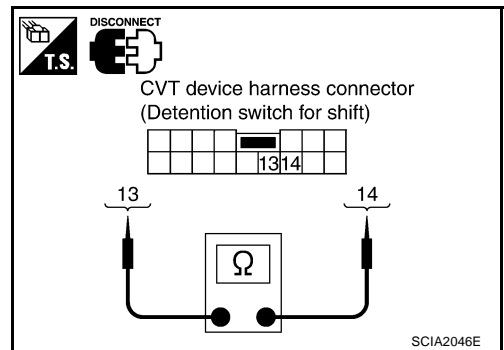

KEY LOCK SOLENOID

Key Lock

- Check operation by applying battery voltage to key switch harness connector.

CAUTION:

Be careful not to cause burnout of the harness.

Connector	Terminal
M28	1 (Battery voltage) - 2 (Ground)

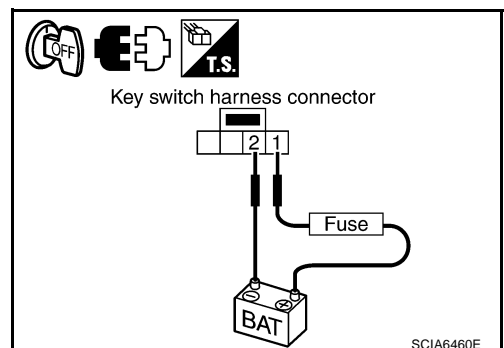

CVT SHIFT LOCK SYSTEM

Key Unlock

- Check operation by applying battery voltage to key switch harness connector.

CAUTION:

Be careful not to cause burnout of the harness.

Connector	Terminal
M28	2 (Battery voltage) - 1 (Ground)

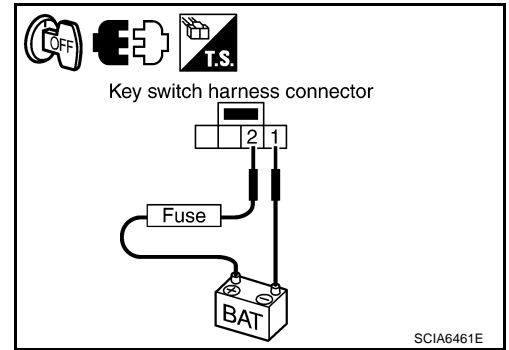

KEY SWITCH

- Check continuity between terminals of the key switch harness connector.

Condition	Connector	Terminal	Continuity
Key inserted	M28	3 - 4	Yes
Key withdrawn			No

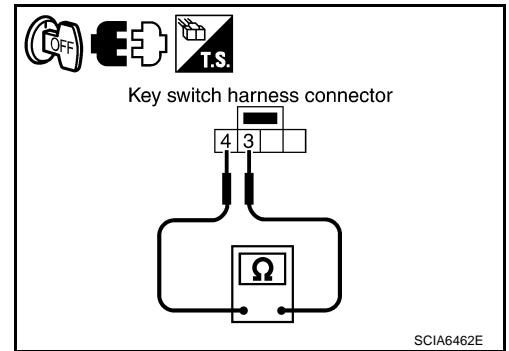

STOP LAMP SWITCH

- Check continuity between terminals of the stop lamp switch harness connector.

Condition	Connector	Terminal	Continuity
When brake pedal is depressed	E116* or M114**	1 - 2	Yes
When brake pedal is released			No

*: LHD models

** : RHD models

Check stop lamp switch after adjusting brake pedal. Refer to [BR-6](#), "[Inspection and Adjustment](#)".

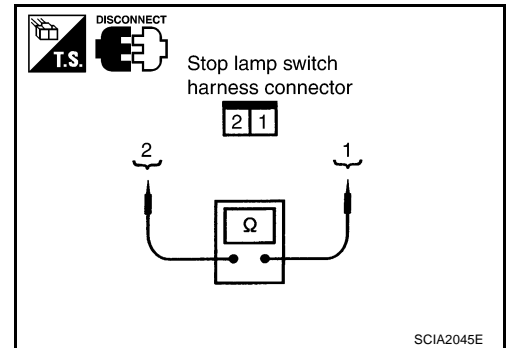

AIR BREATHER HOSE

PFP:31098

AIR BREATHER HOSE Removal and Installation

ECS00FCL

Refer to the figure below for air breather hose removal and installation procedure.

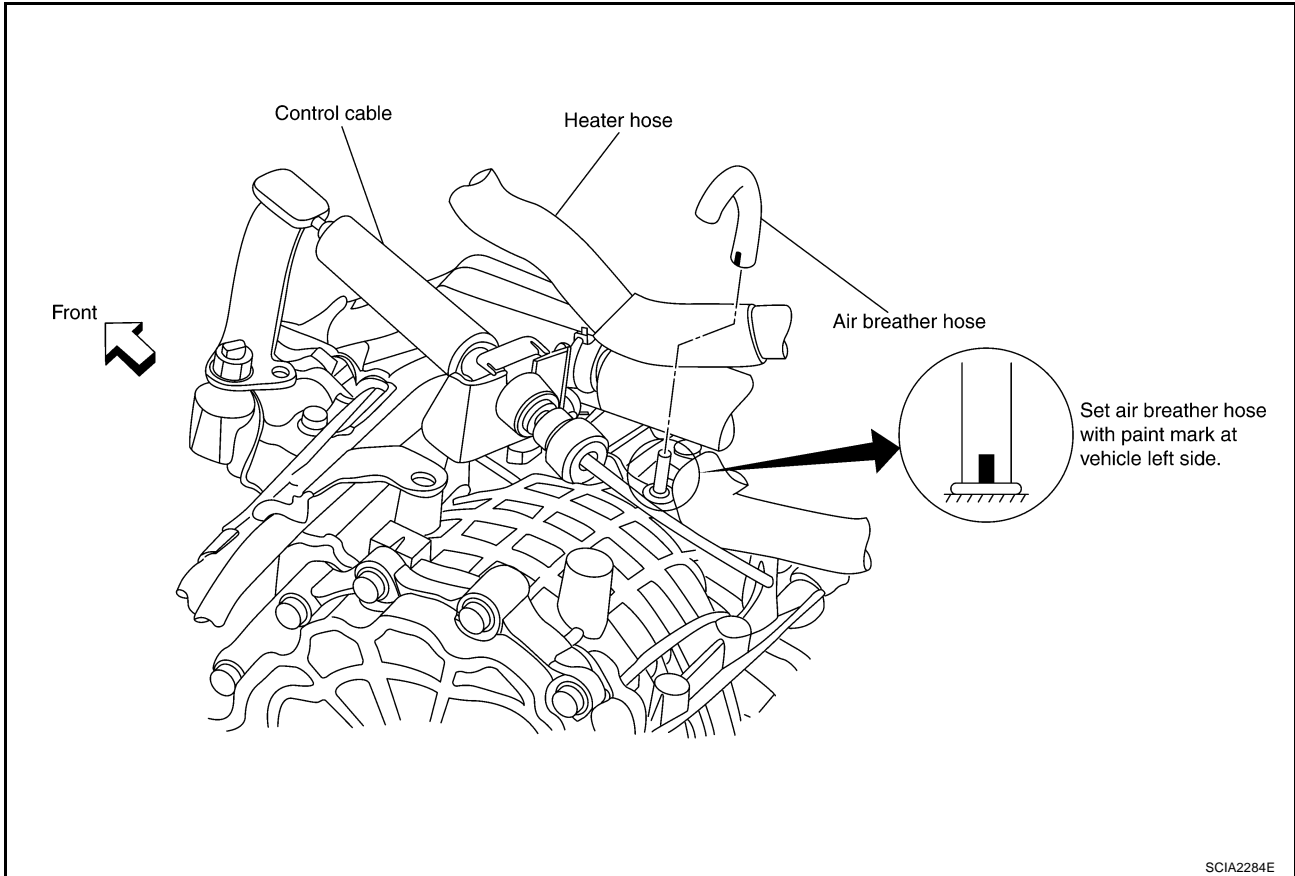

SCIA2284E

CAUTION:

- Securely insert the hose into the air breather until it touches the bottom.

DIFFERENTIAL SIDE OIL SEAL

DIFFERENTIAL SIDE OIL SEAL

PFP:33111

Removal and Installation COMPONENTS

ECS00FCM

A

B

CVT

D

E

F

G

H

I

J

K

L

M

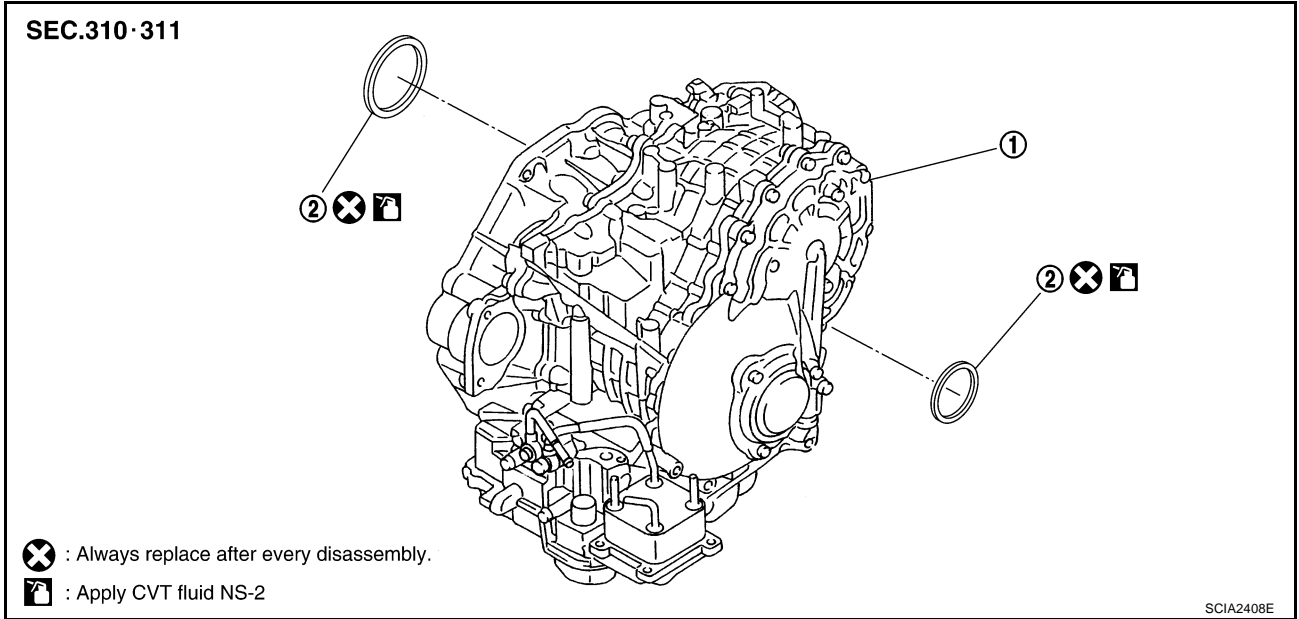

REMOVAL

1. Remove drive shaft assembly. Refer to [FAX-8, "FRONT DRIVE SHAFT"](#) .
2. Remove transfer from transaxle assembly. Refer to [TF-56, "Removal and Installation"](#) .
3. Remove differential side oil seal using a flat-bladed screwdriver.

CAUTION:

Be careful not to scratch transaxle case.

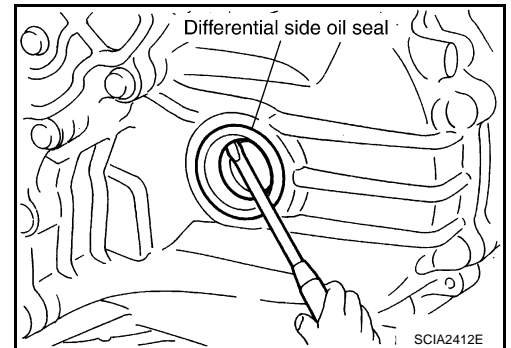

DIFFERENTIAL SIDE OIL SEAL

INSTALLATION

- As shown below, use a drift to drive the differential side oil seal into the case until it is flush. Refer to dimensions A.

Unit: mm (in)

Dimensions A	0 ± 0.5 (0 ± 0.020)
--------------	-------------------------------

NOTE:

The differential side oil seal pulling direction is used as the reference.

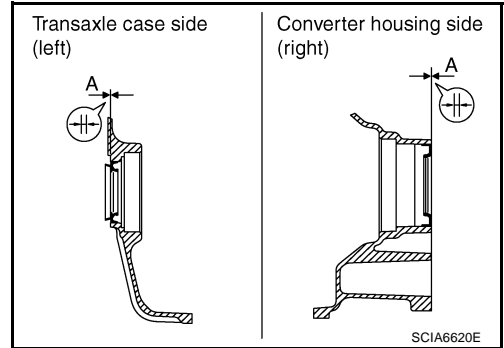

Drift to be used:

Location	Tool number: A
Transaxle case side (left)	ST33400001
Converter housing side (right)	KV40100621

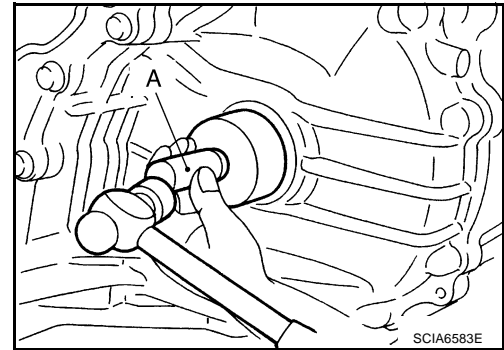

CAUTION:

- When installing differential side oil seal, apply NISSAN CVT Fluid NS-2.
- Do not reuse differential side oil seal.

- Reinstall any part removed.

CAUTION:

If lubricant leak has occurred, after finishing work, check fluid level. Refer to [CVT-14, "Checking CVT Fluid"](#).

CVT FLUID COOLER SYSTEM

CVT FLUID COOLER SYSTEM

PFP:21600

CVT Fluid Cooler Removal and Installation COMPONENTS

ECS00FCZ

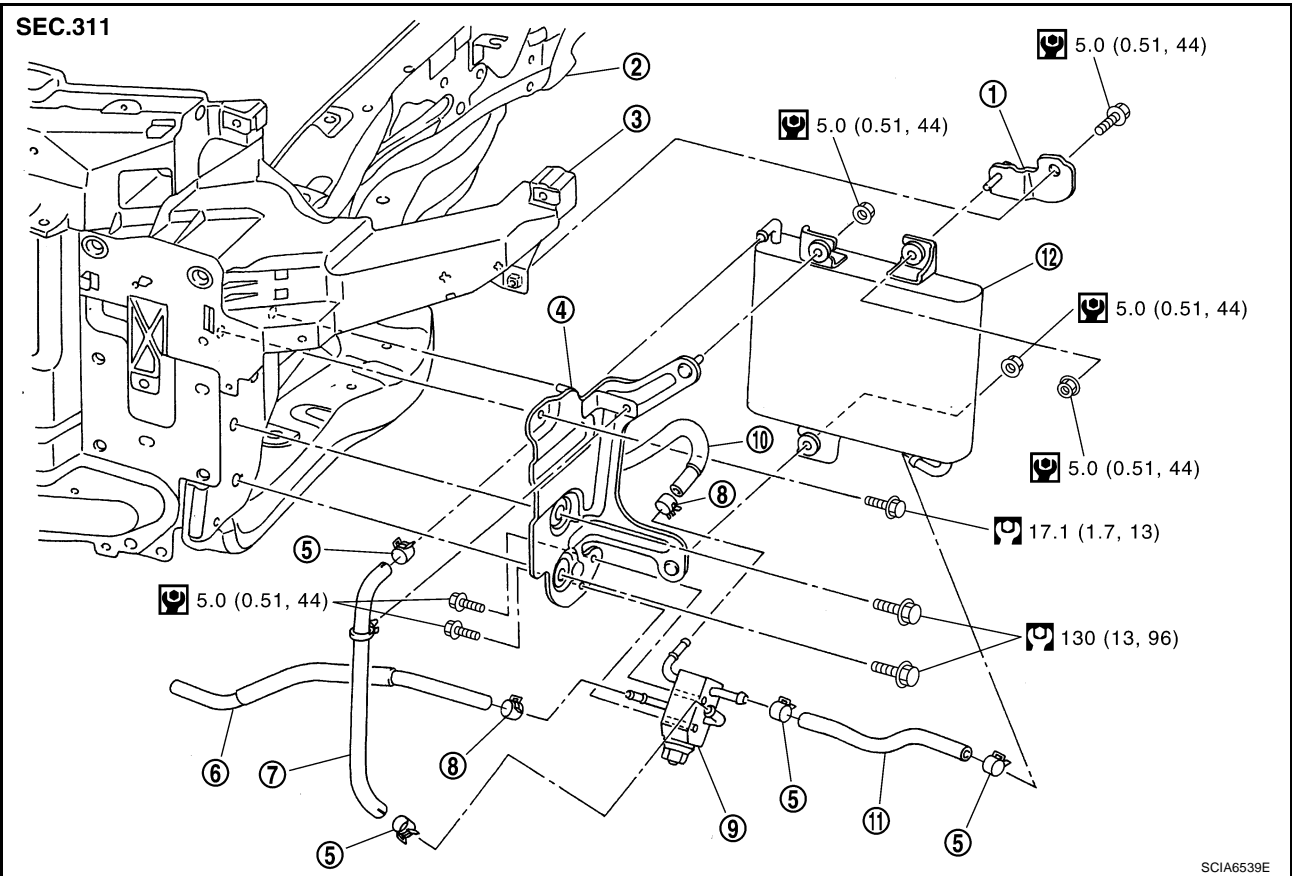

- | | | |
|--|-----------------------------------|--|
| 1. CVT fluid cooler bracket | 2. Side member | 3. Radiator core support (LH) |
| 4. CVT fluid cooler bracket | 5. Hose clamp | 6. CVT fluid cooler hose (radiator to CVT fluid cooler bypass valve) |
| 7. CVT fluid cooler hose (upper) | 8. Hose clamp | 9. CVT fluid cooler bypass valve |
| 10. CVT fluid cooler hose (CVT fluid cooler bypass valve to transaxle) | 11. CVT fluid cooler hose (lower) | 12. CVT fluid cooler |

Refer to GI section to make sure icons (symbol marks) in the figure. Refer to [GI-8, "Components"](#).

REMOVAL

1. Remove front bumper from vehicle. Refer to [EI-17, "Removal and Installation"](#).
2. Remove CVT fluid cooler hose (upper) (1) from CVT fluid cooler bypass valve (2).

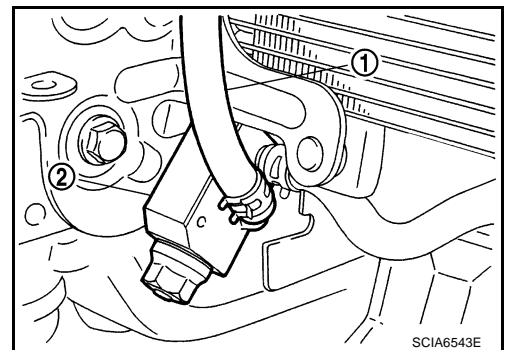

CVT FLUID COOLER SYSTEM

3. Remove clip (1) from CVT fluid cooler bracket (2).

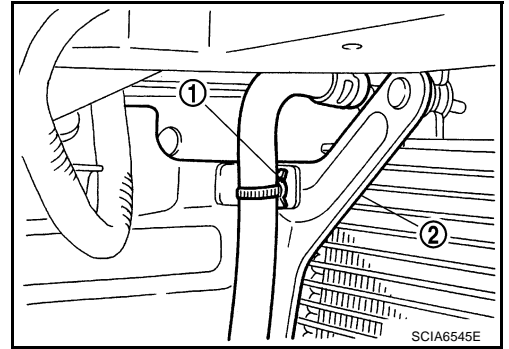

4. Remove CVT fluid cooler hose (lower) (1) from CVT fluid cooler (2).

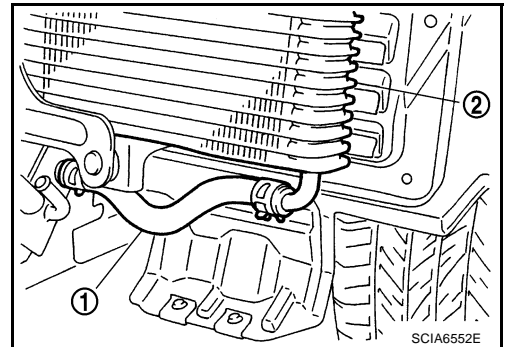

5. Remove CVT fluid cooler (1) from CVT fluid cooler bracket (2).
◀: Nut (3)

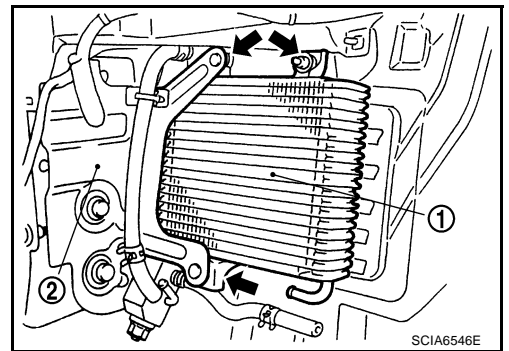

6. Remove CVT fluid cooler hose (upper) (1) from CVT fluid cooler (2).

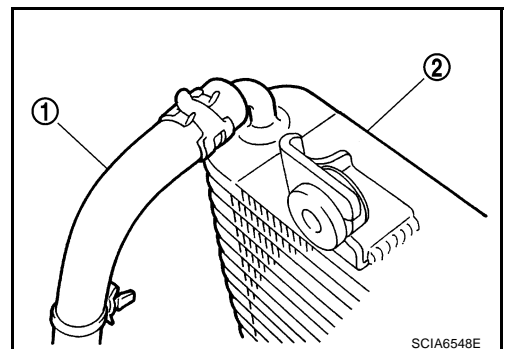

CVT FLUID COOLER SYSTEM

INSTALLATION

Note the following, and install in the reverse order of removal.

- Note the following instruction when inserting CVT fluid cooler hose (upper) into CVT fluid cooler.
 - When inserting CVT fluid cooler hose (upper) into CVT fluid cooler, insert it so as to fit the paint mark (A).
 - When inserting CVT fluid cooler hose (upper) into CVT fluid cooler, insert it with the paint mark (B) facing upward.
 - Install a pawl of hose clamp (1) with it facing upward.

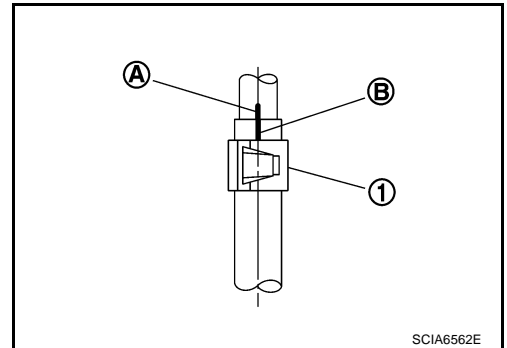

- Note the following instruction when inserting CVT fluid cooler hose (upper) into CVT fluid cooler bypass valve.
 - When inserting CVT fluid cooler hose (upper) into CVT fluid cooler bypass valve, insert it so as to fit the paint mark (A).
 - When inserting CVT fluid cooler hose (upper) into CVT fluid cooler, insert it with the paint mark (B) facing 45 degrees forward of the left side of the vehicle.
 - Install a pawl of hose clamp (1) with it facing 45 degrees forward of the left side of the vehicle.

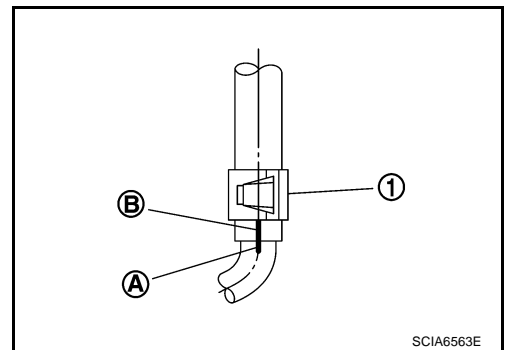

- Insert a clip (1) into bracket mounting hole, and fix CVT fluid cooler hose (upper) securely.

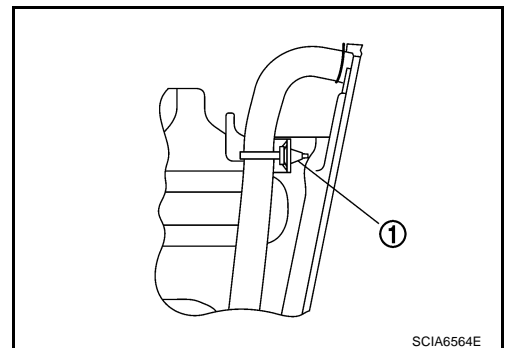

- Note the following instruction when inserting CVT fluid cooler hose (lower) into CVT fluid cooler.
 - When inserting CVT fluid cooler hose (lower) into CVT fluid cooler, insert it so as to fit the paint mark (A).
 - When inserting CVT fluid cooler hose (lower) into CVT fluid cooler, insert it with the paint mark (B) facing backward of the vehicle.
 - Install a pawl of hose clamp (1) with it facing backward of the vehicle.

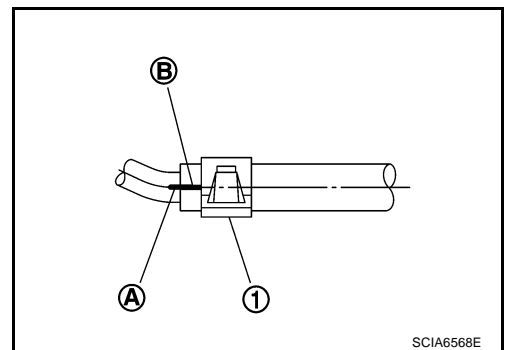

A
B
CVT
D
E
F
G
H
I
J
K
L
M

CVT FLUID COOLER SYSTEM

- Note the following instruction when inserting CVT fluid cooler hose (lower) into CVT fluid cooler bypass valve.
 - When inserting CVT fluid cooler hose (lower) into CVT fluid cooler bypass valve, insert it so as to fit the paint mark (A).
 - When inserting CVT fluid cooler hose (lower) into CVT fluid cooler bypass valve, insert it with the paint mark (B) facing backward of the vehicle.
 - Install a pawl of hose clamp (1) with it facing backward of the vehicle.

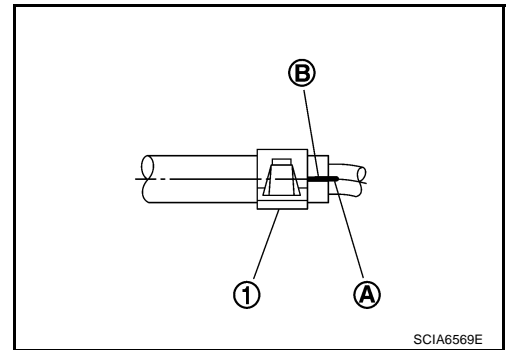

- Install hoses clamp on the position of 5 mm (0.20 in) from the edge of CVT fluid cooler hose.

Distance A: 5 mm (0.20 in)

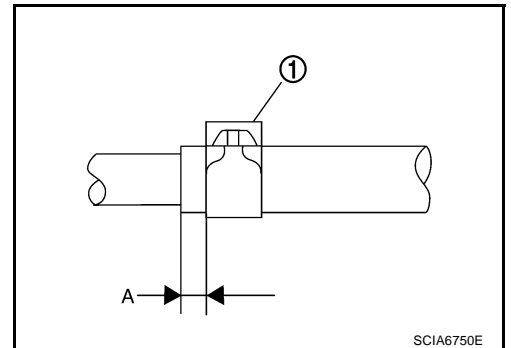

CVT Fluid Cooler Bypass Valve Removal and Installation

ECS00FF4

REMOVAL

1. Remove front bumper from vehicle. Refer to [EI-17, "Removal and Installation"](#).
2. Remove CVT fluid cooler hose (1), (2), (3) and (4) from CVT fluid cooler bypass valve (5).

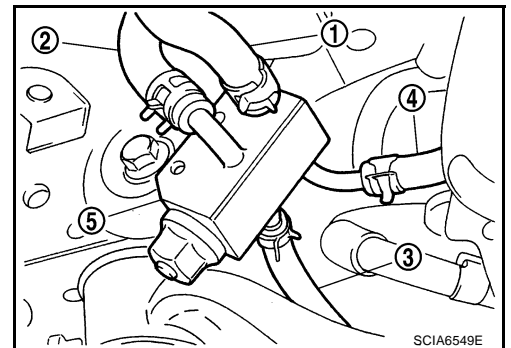

3. Remove CVT fluid cooler bracket (1) from radiator core support (LH) (2).
← Bolt (1)

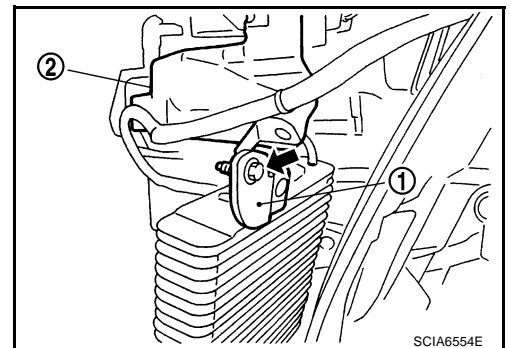

CVT FLUID COOLER SYSTEM

4. Remove CVT fluid cooler bracket (1) from side member (2).

←: Bolt (3)

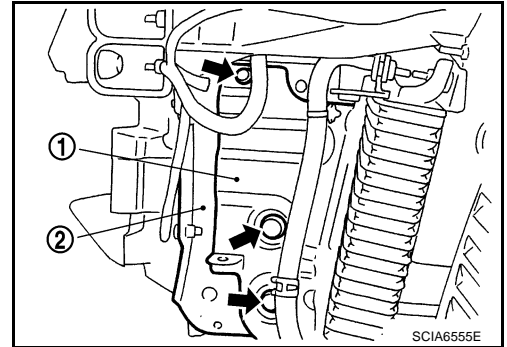

5. Remove CVT fluid cooler bypass valve (1) from CVT fluid cooler bracket (2).

←: Bolt (2)

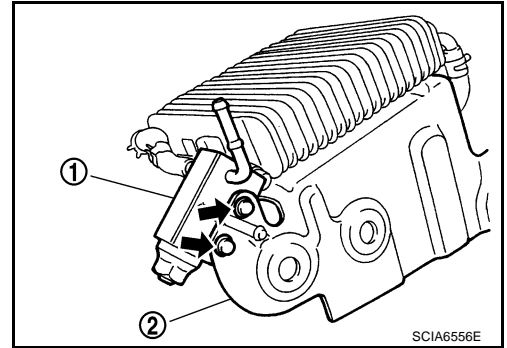

INSTALLATION

Note the following, and install in the reverse order of removal.

- Note the following instruction when inserting CVT fluid cooler hose (radiator to CVT fluid cooler bypass valve) into CVT fluid cooler bypass valve.
 - When inserting CVT fluid cooler hose (radiator to CVT fluid cooler bypass valve) into CVT fluid cooler bypass valve, insert it to the two-stage bulge.
 - When inserting CVT fluid cooler hose (radiator to CVT fluid cooler bypass valve) into CVT fluid cooler bypass valve, insert it with the paint mark (A) facing 45 degrees backward of the downside of the vehicle.
 - Install a pawl of hose clamp (1) with it facing 45 degrees backward of the downside of the vehicle.
- Note the following instruction when inserting CVT fluid cooler hose (CVT fluid cooler bypass valve to transaxle) into CVT fluid cooler bypass valve.
 - When inserting CVT fluid cooler hose (CVT fluid cooler bypass valve to transaxle) into CVT fluid cooler bypass valve, insert it to the two-stage bulge.
 - When inserting CVT fluid cooler hose (CVT fluid cooler bypass valve to transaxle) into CVT fluid cooler bypass valve, insert it with the paint mark (A) facing 45 degrees leftward of the downside of the vehicle.
 - Install a pawl of hose clamp (1) with it facing 45 degrees leftward of the downside of the vehicle.

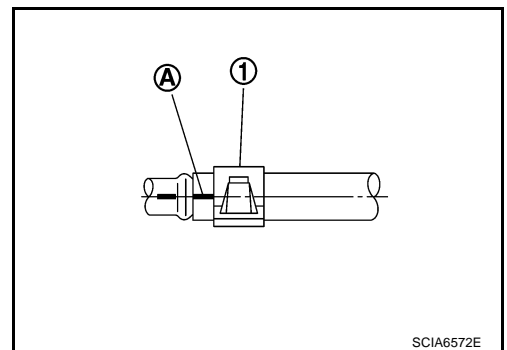
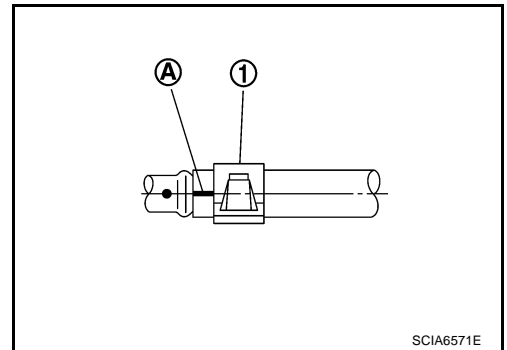

A
B
CVT
D
E
F
G
H
I
J
K
L
M

CVT FLUID COOLER SYSTEM

- Install hoses clamp (1) on the position of 5 mm (0.20 in) from the edge of CVT fluid cooler hose.

Distance A: 5 mm (0.20 in)

- Refer to [CVT-219, "INSTALLATION"](#) when installing CVT fluid cooler hose (upper and lower) to CVT fluid cooler bypass valve.

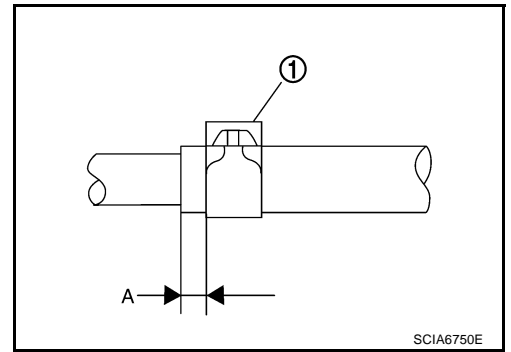

CVT Fluid Cooler Valve Removal and Installation COMPONENTS

ECS00FD0

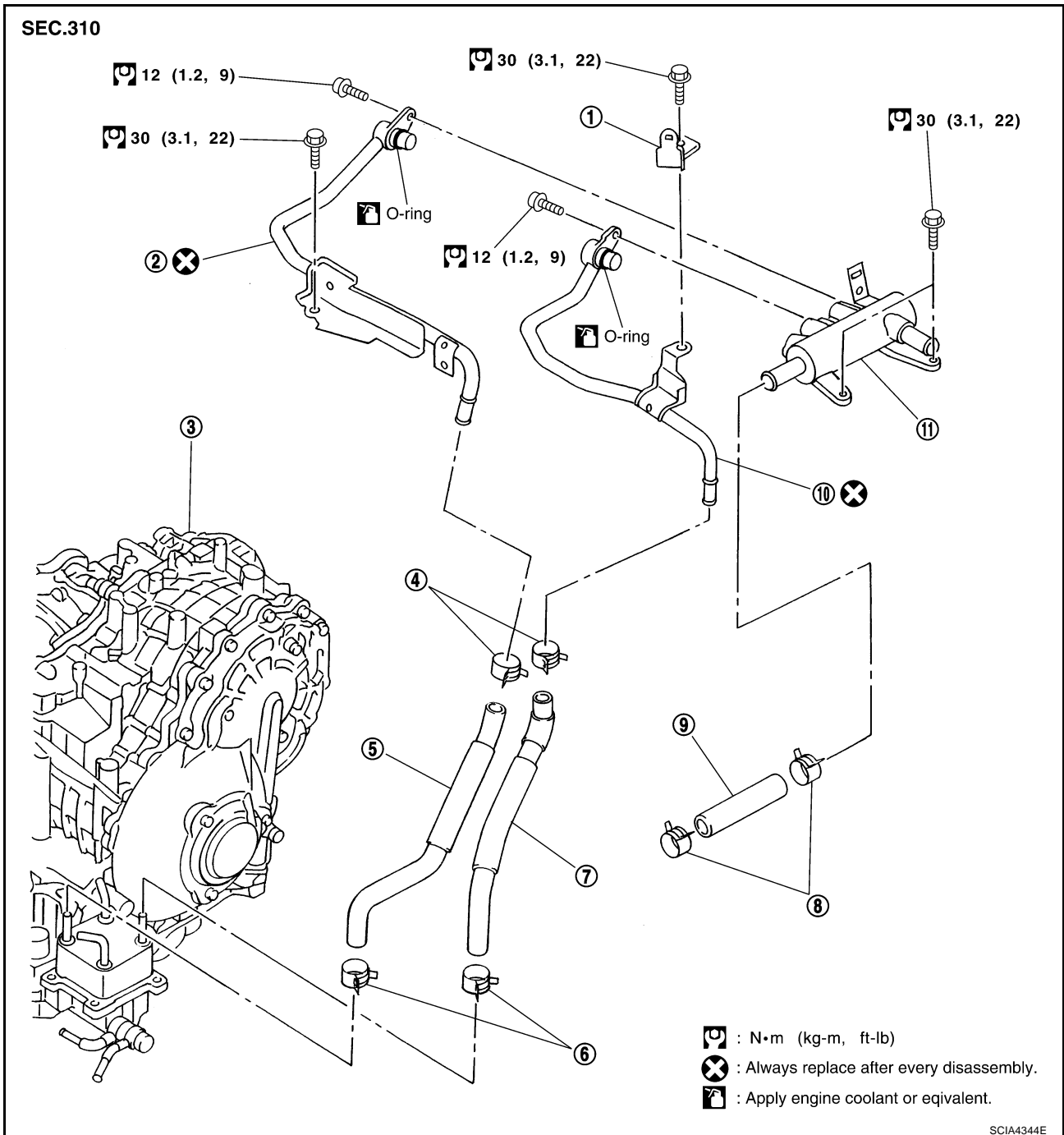

CVT FLUID COOLER SYSTEM

- | | | |
|---|---|-----------------------|
| 1. Harness bracket | 2. CVT fluid cooler inlet tube assembly | 3. Transaxle assembly |
| 4. Hose clamp | 5. Inlet water hose | 6. Hose clamp |
| 7. Outlet water hose | 8. Hose clamp | 9. Heater hose |
| 10. CVT fluid cooler outlet tube assembly | 11. CVT fluid cooler valve assembly | |

REMOVAL

WARNING:

Never remove the radiator cap when the engine is hot. Serious burns could occur from high pressure engine coolant escaping from the radiator.

1. Remove engine undercover.
2. Drain engine coolant. Refer to [CO-9, "Changing Engine Coolant"](#) .

CAUTION:

Perform when the engine is cold.

3. Remove air duct (inlet). Refer to [EM-15, "Removal and Installation"](#) .
4. Remove battery. Refer to [SC-12, "Removal and Installation"](#) .
5. Remove air cleaner case (upper and lower), resonator, mass air flow sensor and air duct assembly. Refer to [EM-15, "Removal and Installation"](#) .
6. Remove fuse and fusible link block from battery bracket.

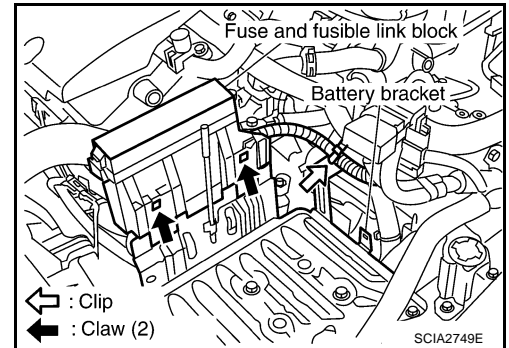

7. Remove battery bracket.

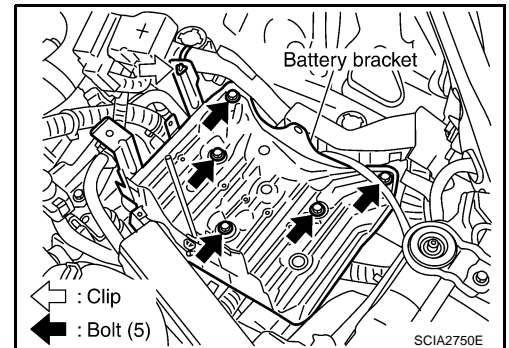

8. Remove battery bracket mounting.

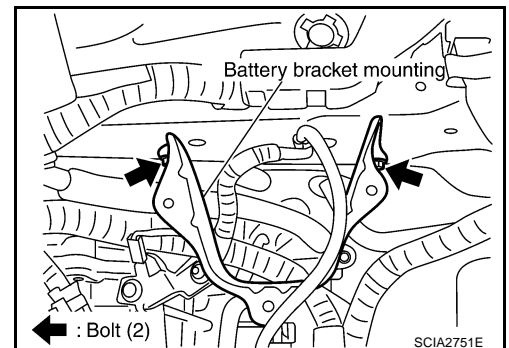

A
B
CVT
D
E
F
G
H
I
J
K
L
M

CVT FLUID COOLER SYSTEM

9. Remove air cleaner bracket. Refer to [EM-15, "Removal and Installation"](#).
10. Remove control cable from transaxle assembly. Refer to [CVT-202, "Removal and Installation"](#).

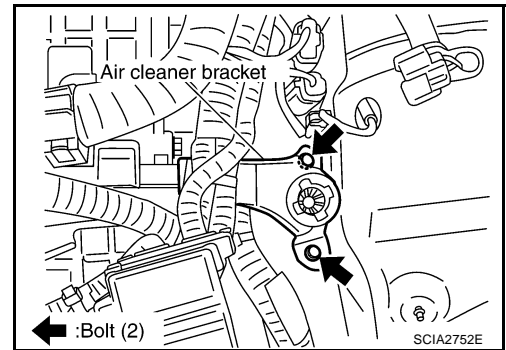

11. Remove water bypass hose from water bypass pipe. Refer to [CO-29, "Removal and Installation"](#).

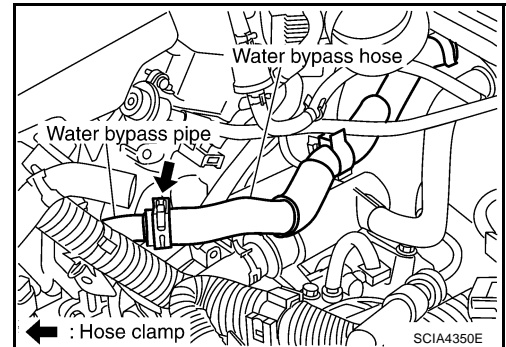

12. Remove harness bracket and control cable bracket from transaxle assembly. Refer to [CVT-202, "Removal and Installation"](#) and [CVT-222, "COMPONENTS"](#).
13. Remove inlet water hose and outlet water hose. Refer to [CVT-222, "COMPONENTS"](#).
14. Remove heater hose from heater pipe. Refer to [CO-29, "Removal and Installation"](#).
15. Remove CVT fluid cooler valve assembly from transaxle assembly. Refer to [CVT-222, "COMPONENTS"](#).

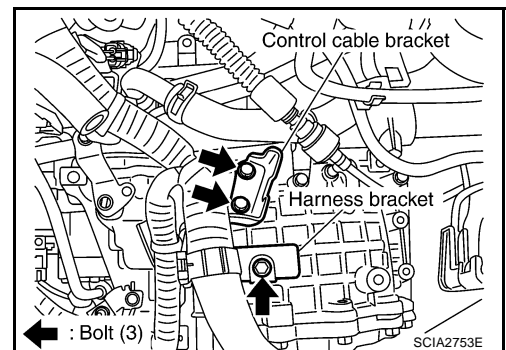

16. Remove heater hose from CVT fluid cooler valve assembly.

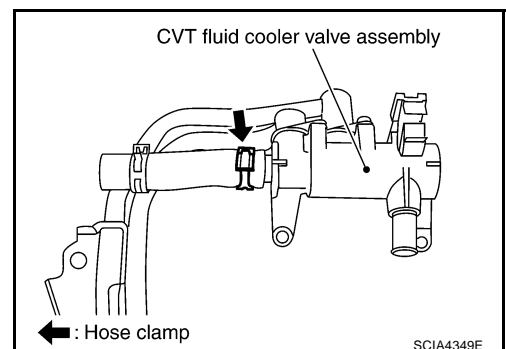

17. Remove CVT fluid cooler inlet tube assembly and CVT fluid cooler outlet tube assembly from CVT fluid cooler valve assembly.

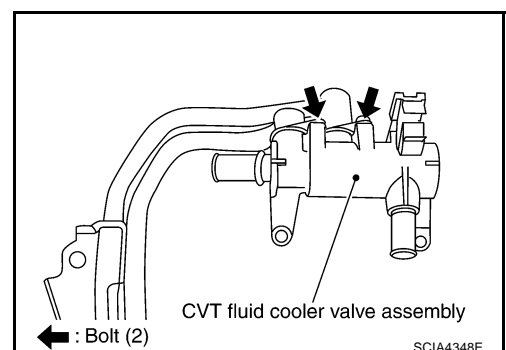

CVT FLUID COOLER SYSTEM

INSTALLATION

Note the following, and install in the reverse order of removal.

- After completing installation, check for engine coolant leakage, engine coolant level, and the positions of CVT. Refer to [CO-9, "Inspection"](#) and [CVT-205, "Checking of CVT Position"](#).

CAUTION:

- Install hose clamp with tabs aligned with markings of CVT fluid cooler valve assembly and each hose.
- Do not reuse CVT fluid cooler inlet tube assembly and CVT fluid cooler outlet tube assembly.
- Apply LLC around O-ring when installing CVT fluid cooler inlet tube and CVT fluid cooler outlet tube assembly to CVT fluid cooler valve assembly.

COMPONENT INSPECTION

1. Make sure that CVT fluid cooler valve is fully opened at room temperature.

Standard

Dimension A from CVT fluid cooler valve port end to tip of valve shaft

(At room temperature):

Approx 72.0 mm (2.835 in) or more

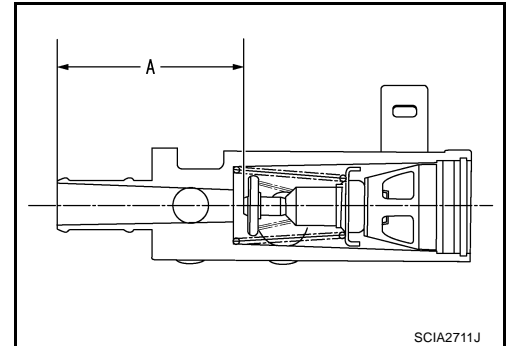

2. Put CVT fluid cooler valve into a water-filled container, and then heat it up to 82°C (180°F) or more for 10 minutes or more.

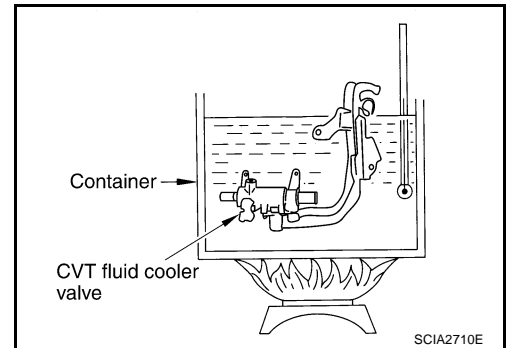

3. Make sure that CVT fluid cooler valve is fully closed.

Standard

Dimension A from CVT fluid cooler valve port end to tip of valve shaft

(When heating to 82°C (180°F) or more for 10 minutes or more):

Approx 66.5 mm (2.618 in) or less

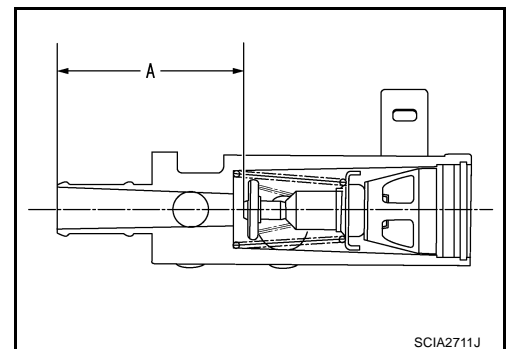

A
B
CVT
D
E
F
G
H
I
J
K
L
M

TRANSAXLE ASSEMBLY

PFP:32020

ECS00FCP

TRANSAXLE ASSEMBLY

Removal and Installation COMPONENTS

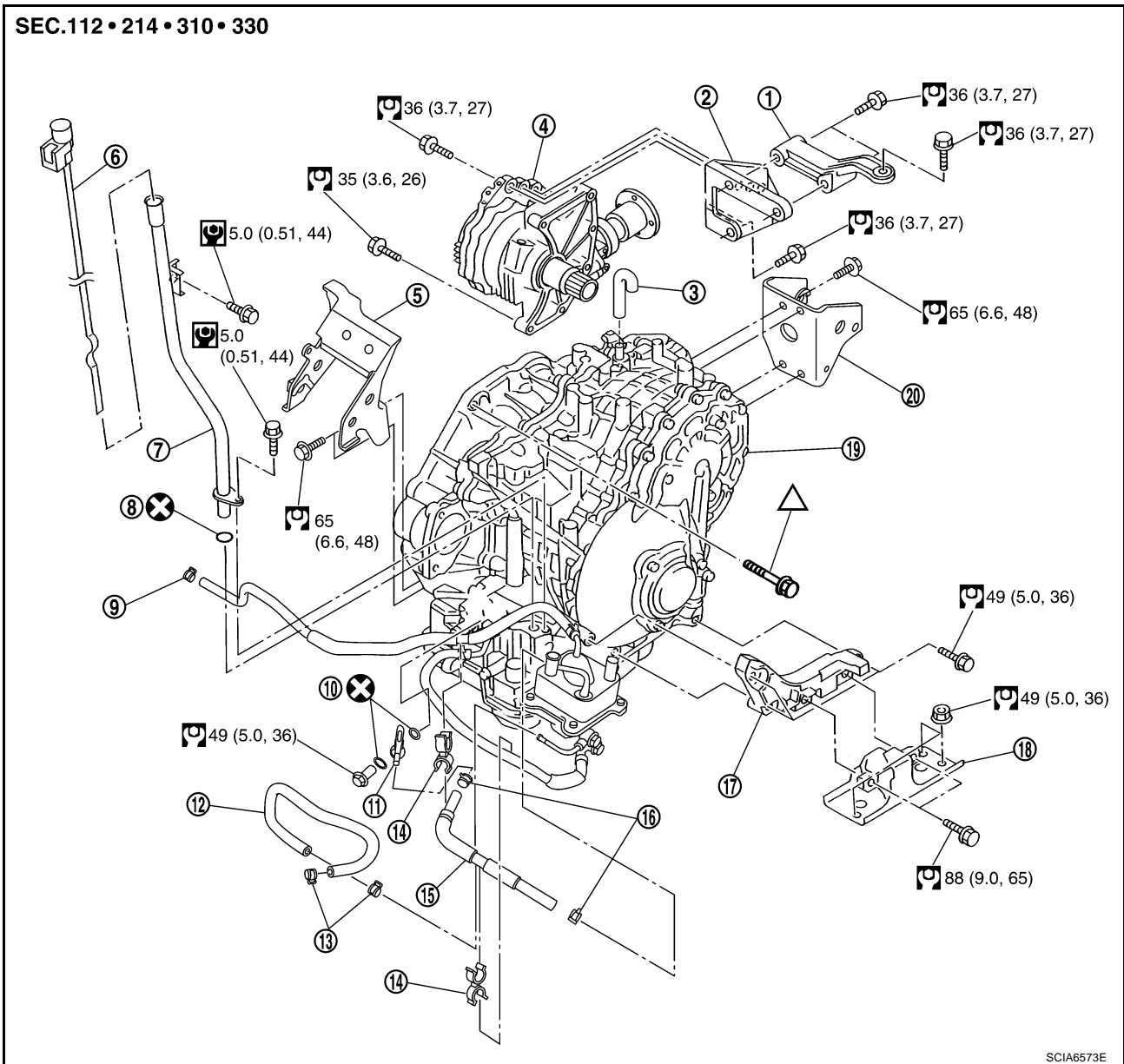

- | | | |
|----------------------------|----------------------------------|----------------------------------|
| 1. Rear gusset | 2. Transfer gusset | 3. Air breather hose |
| 4. Transfer assembly | 5. Front engine mounting bracket | 6. CVT fluid level gauge |
| 7. CVT fluid charging pipe | 8. O-ring | 9. Hose clamp |
| 10. Copper washer | 11. Fluid cooler tube | 12. CVT fluid cooler hose |
| 13. Hose clamp | 14. Clip | 15. CVT fluid cooler hose |
| 16. Hose clamp | 17. LH engine mounting bracket | 18. LH engine mounting insulator |
| 19. Transaxle assembly | 20. Rear engine mounting bracket | |

Refer to GI section to make sure icons (symbol marks) in the figure. Refer to [GI-8, "Components"](#) .

△ : For tightening torque, refer to [CVT-230, "INSTALLATION"](#) .

TRANSAXLE ASSEMBLY

REMOVAL

CAUTION:

The transaxle assembly itself cannot be removed from the vehicle. Remove the transaxle assembly and engine assembly together from the vehicle.

1. Disconnect the batter cable from the negative terminal.
2. Remove engine undercover.
3. Remove air guide.
4. Remove exhaust front tube with power tool. Refer to [EX-3, "Removal and Installation"](#).

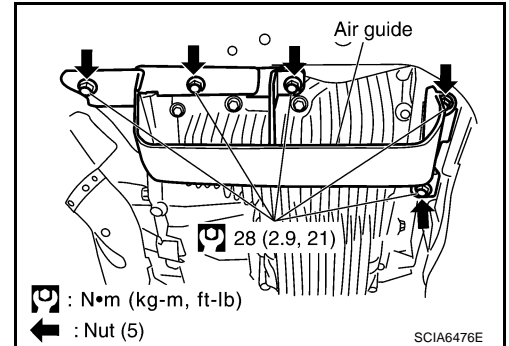

5. Remove rear plate cover. Refer to [EM-28, "Removal and Installation"](#).

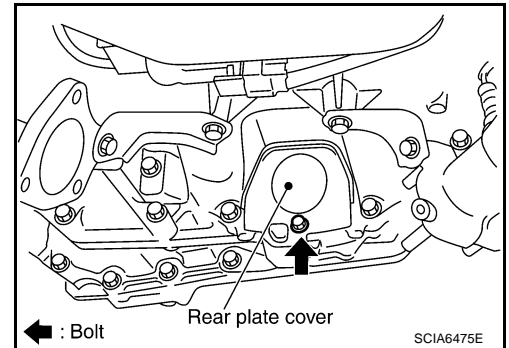

6. Turn crankshaft, and remove the four tightening nuts for drive plate and torque converter.

CAUTION:

The crankshaft should be rotated clockwise, viewed from the front of the engine.

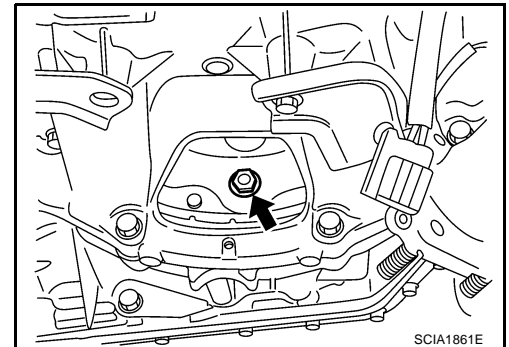

7. Remove the six bolts in the figure.
8. Remove transaxle assembly and engine assembly together from the vehicle. Refer to [EM-104, "Removal and Installation"](#).
9. Remove drive shaft. Refer to [FAX-11, "Removal and Installation \(Left Side\)"](#), [FAX-13, "Removal and Installation \(Right Side\)"](#).

CAUTION:

Be sure to replace the differential side oil seal with new one at the every removal of drive shaft. Refer to [CVT-215, "Removal and Installation"](#).

10. Remove transfer gusset.
11. Remove transfer assembly. Refer to [TF-56, "Removal and Installation"](#).

CAUTION:

Be sure to replace the differential side oil seal with new one (converter housing side only) at the every removal of transfer. Refer to [CVT-215, "Removal and Installation"](#).

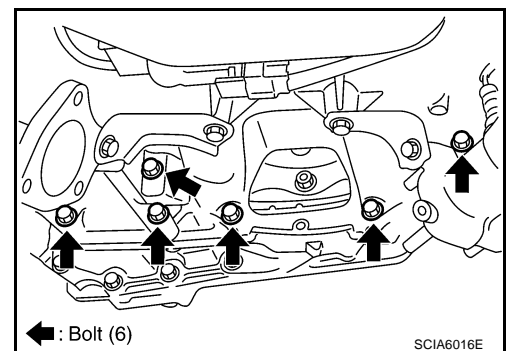

A
B
CVT
D
E
F
G
H
I
J
K
L
M

TRANSAXLE ASSEMBLY

12. Remove CVT fluid charging pipe.
13. Remove O-ring from CVT fluid charging pipe.
14. Disconnect harness connector and wire harness.

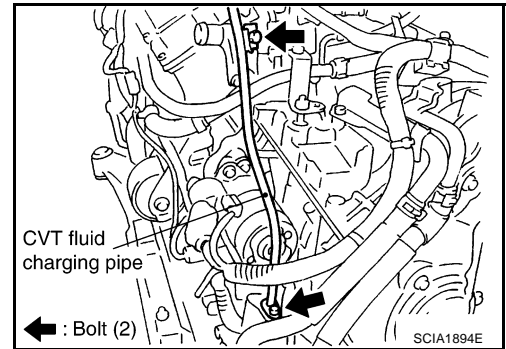

15. Remove crankshaft position sensor (POS) (1) from engine assembly. Refer to [EM-28, "Removal and Installation"](#).

CAUTION:

- Do not subject it to impact by dropping or hitting it.
- Do not disassemble.
- Do not allow metal filings, etc., to get on the sensor's front edge magnetic area.
- Do not place in an area affected by magnetism.

16. Remove starter motor. Refer to [SC-16, "Removal and Installation"](#).

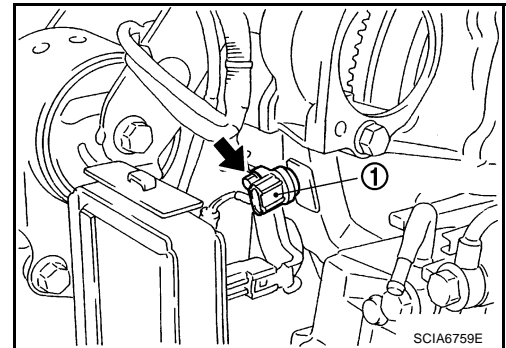

17. Remove CVT fluid cooler valve assembly (1). (With CVT fluid cooler tube assembly and heater hose). Refer to [CVT-222, "CVT Fluid Cooler Valve Removal and Installation"](#).

- (A): Bolt (4)
(B): Hose clamp (3)

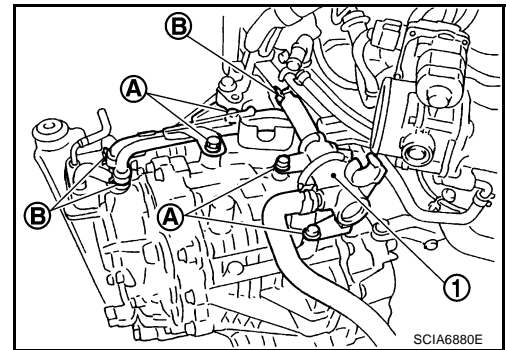

18. Install slinger to transaxle assembly.
19. Remove rear gusset.
20. Remove LH engine mounting bracket and LH engine mounting insulator.
21. Remove front suspension member from transaxle assembly and engine assembly. Refer to [EM-104, "Removal and Installation"](#).
22. Remove transaxle assembly fixing bolts with power tool.

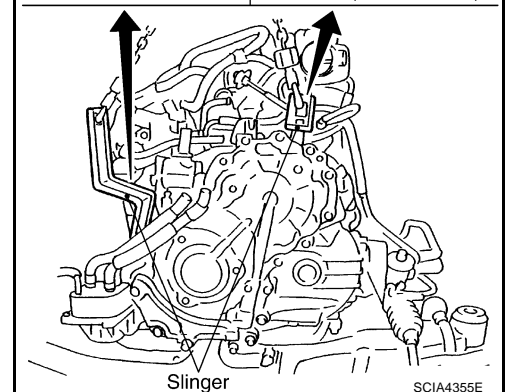
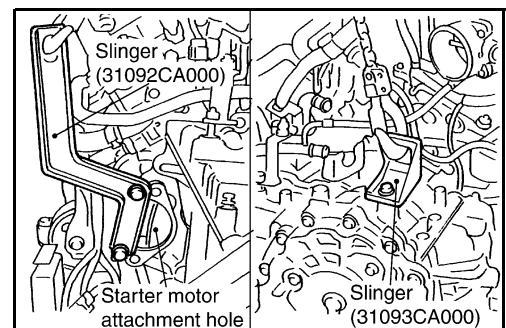

TRANSAXLE ASSEMBLY

23. Remove transaxle assembly from engine assembly with a hoist.
- **Secure torque converter to prevent it from dropping.**

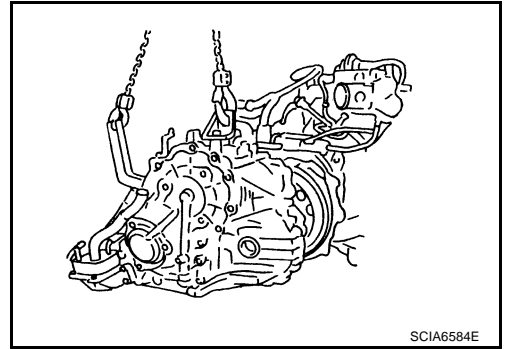

A
B
CVT

INSPECTION

Installation and Inspection of Torque Converter

- After inserting a torque converter to a transaxle, be sure to check distance "A" to ensure it is within the reference value limit.

Distance "A": 14.0 mm (0.55 in) or more

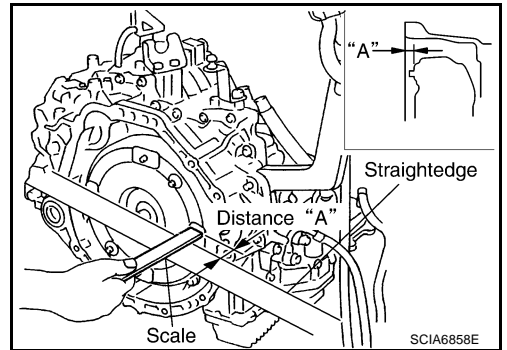

D
E
F
G
H
I
J
K
L
M

TRANSAXLE ASSEMBLY

INSTALLATION

Note the following, and install in the reverse order of removal.

- Set and screw in the drive plate location guide onto the stud bolts for the torque converter locate.

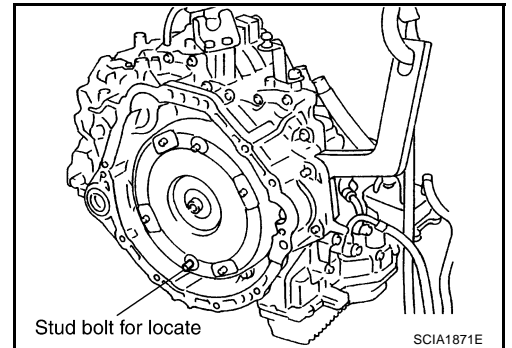

- Rotate the torque converter for the locate to go down.

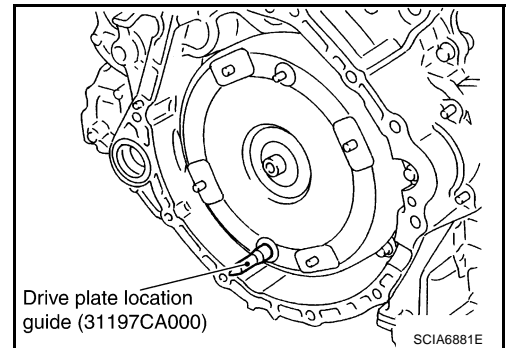

- Rotate the drive plate for the hole of the drive plate locate to go down.

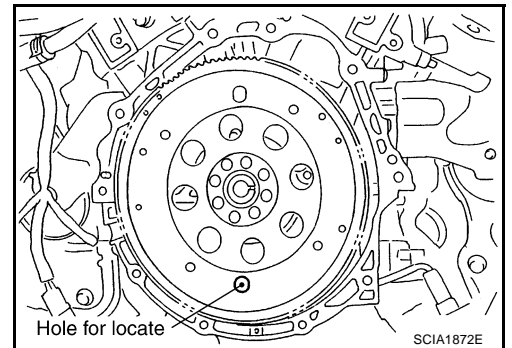

- Install transaxle assembly to engine assembly with a hoist.

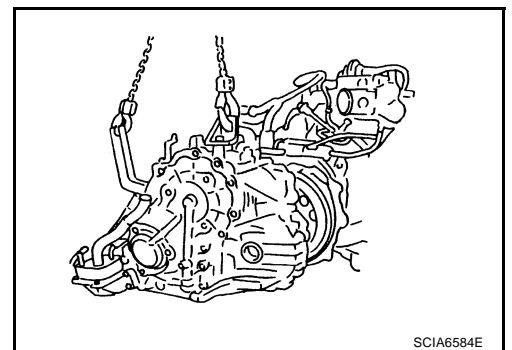

TRANSAXLE ASSEMBLY

- When installing fluid cooler tube to transaxle assembly, assemble the part with the tube aligned with the rib.

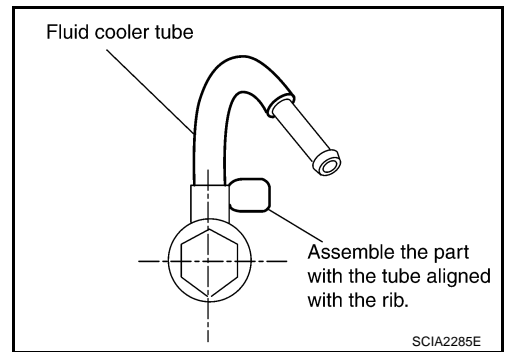

- When installing transaxle to the engine, attach the fixing bolts in accordance with the following standard.

Bolt No.	1	2	3	4
Number of bolts	1	2	2	4
Bolt length "ℓ" mm (in)	52 (2.05)	36 (1.42)	105 (4.13)	35 (1.38)
Tightening torque N-m (kg-m, ft-lb)	75 (7.7, 55)			47 (4.8, 35)

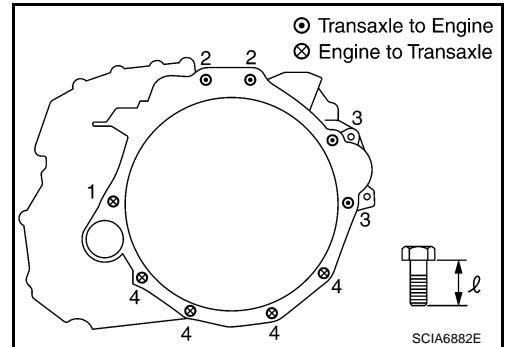

- Align the positions of tightening nuts for drive plate with those of the torque converter, and temporarily tighten the nuts. Then, tighten the nuts with the specified torque.

 : 51N·m (5.2 kg-m, 38 ft-lb)

CAUTION:

- When turning crankshaft, turn it clockwise as viewed from the front of the engine.
- When tightening the tightening nuts for the torque converter after fixing the crankshaft pulley bolts, be sure to confirm the tightening torque of the crankshaft pulley mounting bolts. Refer to [EM-64, "INSTALLATION"](#).
- After converter is installed to drive plate, rotate crankshaft several turns and check to be sure that transaxle rotates freely without binding.
- Install crankshaft position sensor (POS). Refer to [EM-28, "Removal and Installation"](#).
- After completing installation, check for fluid leakage, fluid level, and the positions of CVT. Refer to [CVT-14, "Checking CVT Fluid"](#), [CVT-204, "Adjustment of CVT Position"](#), [CVT-205, "Checking of CVT Position"](#).
- When replacing the CVT assembly, erase EEP ROM in TCM. Refer to [CVT-8, "Precautions for TCM and CVT Assembly Replacement"](#).

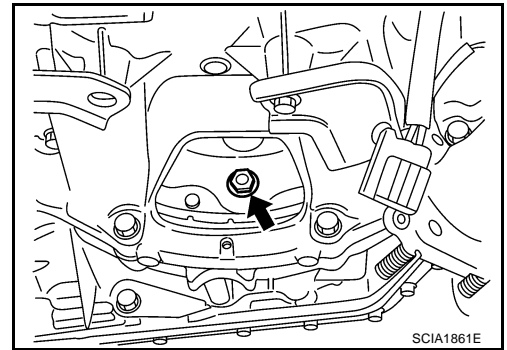

SERVICE DATA AND SPECIFICATIONS (SDS)

SERVICE DATA AND SPECIFICATIONS (SDS)

PFP:00030

General Specifications

ECS00FCQ

Applied model		VQ35DE engine
		4WD
CVT model		RE0F09A
CVT assembly	Model code number	1XD0A
Transmission gear ratio	D range	Variable
	Reverse	1.766
	Final drive	5.173
Recommended fluid		NISSAN CVT fluid NS-2*1
Fluid capacity		10.0 liter (8-3/4 Imp qt)

CAUTION:

- Use only Genuine NISSAN CVT fluid NS-2. Do not mix with other fluid.
- Using CVT fluid other than Genuine NISSAN CVT fluid NS-2 will deteriorate in driveability and CVT durability, and may damage the CVT, which is not covered by the warranty.

*1: Refer to [MA-14, "Fluids and Lubricants"](#) .

Vehicle Speed at Which Gear Shifting Occurs

ECS00FCR

Numerical value data are reference values.

Engine type	Throttle position	Shift pattern	Engine speed (rpm)	
			At 40 km/h (25 MPH)	At 60 km/h (37 MPH)
VQ35DE	8/8	"D" position	2,800 - 4,300	3,900 - 5,300
	2/8	"D" position	1,200 - 2,000	1,300 - 2,100

CAUTION:

Lock-up clutch is engaged when vehicle speed is approximately 18 km/h (11 MPH) to 90 km/h (56 MPH).

Stall Speed

ECS00FCS

Stall speed	2,700 - 3,250 rpm
-------------	-------------------

Line Pressure

ECS00FCT

Engine	Engine speed	Line pressure kPa (kg/cm ² , psi)
		"R", "D" positions
VQ35DE	At idle speed	750 (7.65, 108.8)
	At stall speed	5,700 (58.14, 826.5)* ¹

*¹ : Reference values

Solenoid Valves

ECS00FCU

Name	Resistance (Approx.) (Ω)	Terminal
Pressure control solenoid valve B (Secondary pressure solenoid valve)	3 - 9	3
Pressure control solenoid valve A (Line pressure solenoid valve)		2
Torque converter clutch solenoid valve		12
Lock-up select solenoid valve	6 - 19	13

SERVICE DATA AND SPECIFICATIONS (SDS)

CVT Fluid Temperature Sensor

ECS00FCV

Item name	Condition	CONSULT-II "DATA MONITOR" (Approx.) (V)	Resistance (Approx.) (kΩ)
ATF TEMP SEN	20°C (68°F)	1.8 - 2.0	6.5
	80°C (176°F)	0.6 - 1.0	0.9

Primary Speed Sensor

ECS00FCW

Name	Condition	Data (Approx.)
Primary speed sensor	When driving ["D" position, 20 km/h (12 MPH)].	600 (Hz)

Secondary Speed Sensor

ECS00FCX

Name	Condition	Data (Approx.)
Secondary speed sensor	When driving ["D" position, 20 km/h (12 MPH)].	300 (Hz)

Removal and Installation

ECS00FCY

Distance between end of converter housing and torque converter	14.0 mm (0.55 in) or more
--	---------------------------

A
B
CVT
D
E
F
G
H
I
J
K
L
M

SERVICE DATA AND SPECIFICATIONS (SDS)
