

## ● ELECTRONIC CONTROL SYSTEM

### 1. General

The electronic control system of the A960E automatic transmissions consist of the control functions listed below.

System	Function
Shift Timing Control	The ECM sends current to solenoid valves S1, S2, S3, S4 and/or SR based on signals from various sensors, in order to shift the gears.
Clutch Pressure Control (See page CH-39)	<ul style="list-style-type: none"> <li>Controls the pressure that is applied directly to B<sub>2</sub> brake and C<sub>3</sub> clutch by actuating the linear solenoid valves SL1 and SL2 in accordance with the ECM signals.</li> <li>The solenoid valve SLT and SL1 minutely control the clutch pressure in accordance with the engine output and driving conditions.</li> </ul>
Line Pressure Control (See page CH-40)	Based on the throttle opening angle and various signals, the ECM sends a signal to solenoid valve SLT to generate line pressure that varies according to the engine output and to allow smooth gear changes.
Engine Torque Control	Retards the engine ignition timing temporarily to improve shift feeling while upshifts or downshifts occur.
High Response Shift Control	Though cooperative control with ETCS-i (Electronic Throttle Control System-intelligent), and the electronic control of application and release speed of the clutch and brake hydraulic pressures, excellent response has been realized.
Lock-up Timing Control (See page CH-40)	While in 5th or 6th gear when the shift lever is in the D position or S6 range, the ECM sends current to the shift solenoid valve SLU based on the signals from the sensors and engages or disengages the lock-up clutch. This control also applies for 5th gear when the shift lever is in the S5 range and in the 4th gear when the shift lever is in the S4 range.
Flex Lock-up Clutch Control (See page CH-41)	<ul style="list-style-type: none"> <li>Controls the solenoid valve SLU, provides an intermediate mode between the ON/OFF operation of the lock-up clutch, and increases the operating range of the lock-up clutch to improve fuel economy.</li> <li>The flex lock-up clutch control operates in the 3rd, 4th, 5th and 6th gears in both D position and S6 range, 3rd, 4th and 5th gears in the S5 range and 3rd and 4th gears in the S4 range.</li> </ul>
AI (Artificial Intelligence) -SHIFT (See page CH-42)	Based on the signals from various sensors, the ECM determines the road condition and the intention of the driver. While the pattern select switch is in POWER, the shift pattern is biased toward sporty driving. Thus, an appropriate shift pattern is automatically determined, thus improving drivability.
Orifice Switching Control (See page CH-44)	The orifice switching control prevents the oil pump from drawing air during extremely low temperatures while in 1st gear.
Multi-Mode Automatic Transmission (See page CH-45 )	The ECM appropriately controls the automatic transmission in accordance with the range position selected while the shift lever is in the S mode position.
Vehicle lift Control	To restrain the upward movement of the vehicle when the shift lever is moved from the D position to N, the clutch release speed has been optimized.
Shift Down Control	In order to ensure a smooth shift feel during downshifting to accelerate the vehicle, the hydraulic passages and control have been optimized.

(Continued)

---

<b>System</b>	<b>Function</b>
Diagnosis (See page CH-48)	When the ECM detects a malfunction, the ECM makes a diagnosis and memorizes the information that relates to the fault.
Fail-safe (See page CH-48)	If a malfunction is detected in the sensors or solenoids, the ECM effects fail-safe control to prevent the vehicle's drivability from being affected significantly.

**2. Construction**

The configuration of the electronic control system in the A960E is as shown in the following chart.

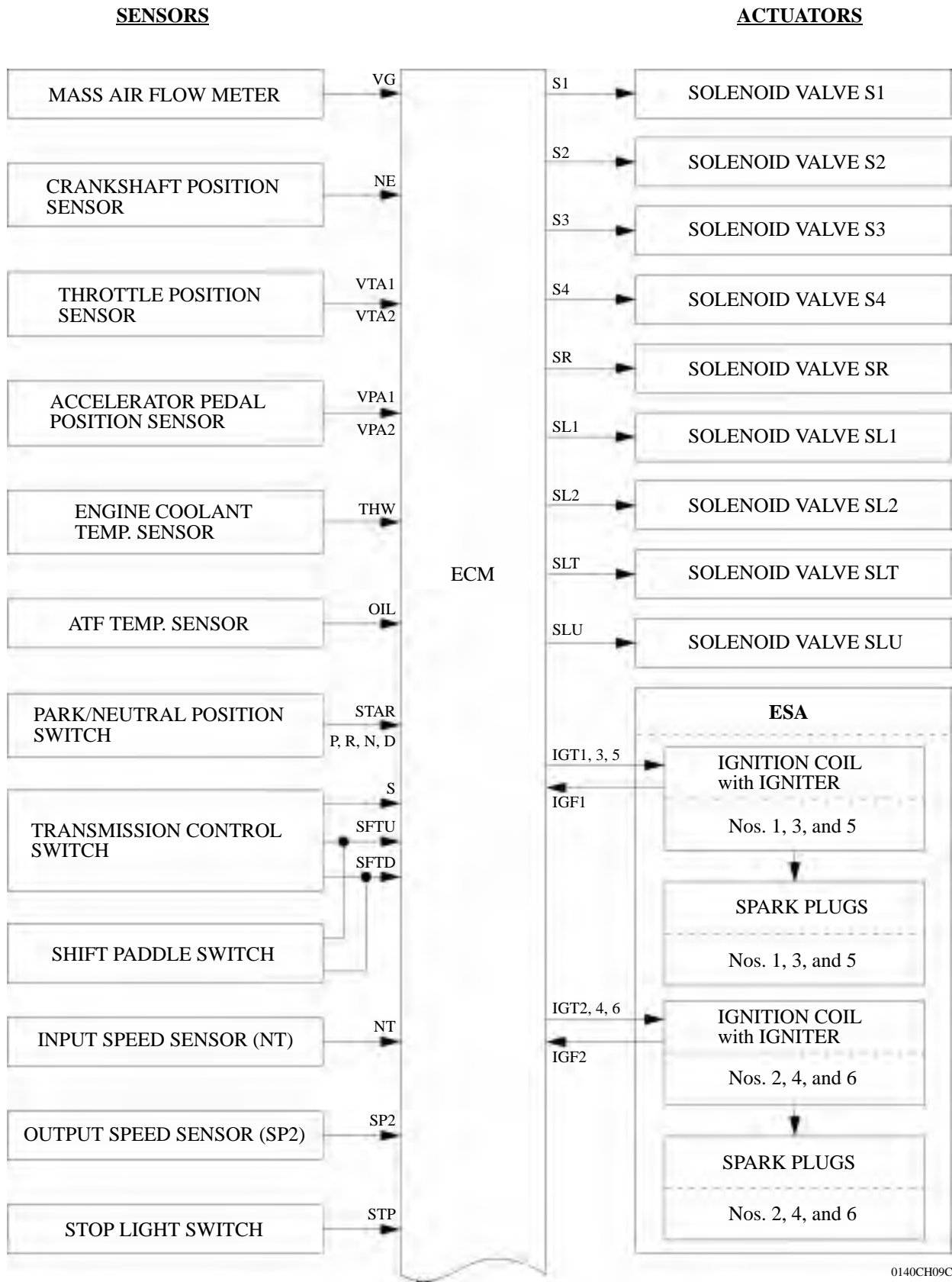

0140CH09C

(Continued)

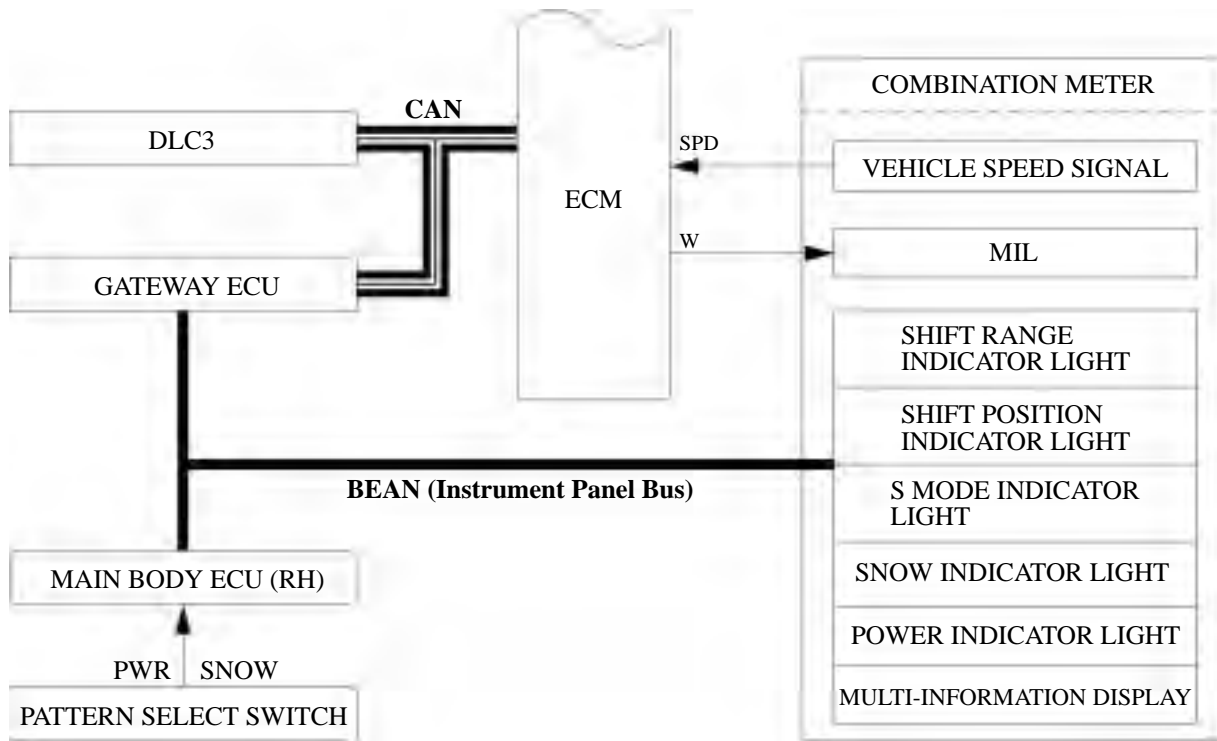

3. Layout of Main Component

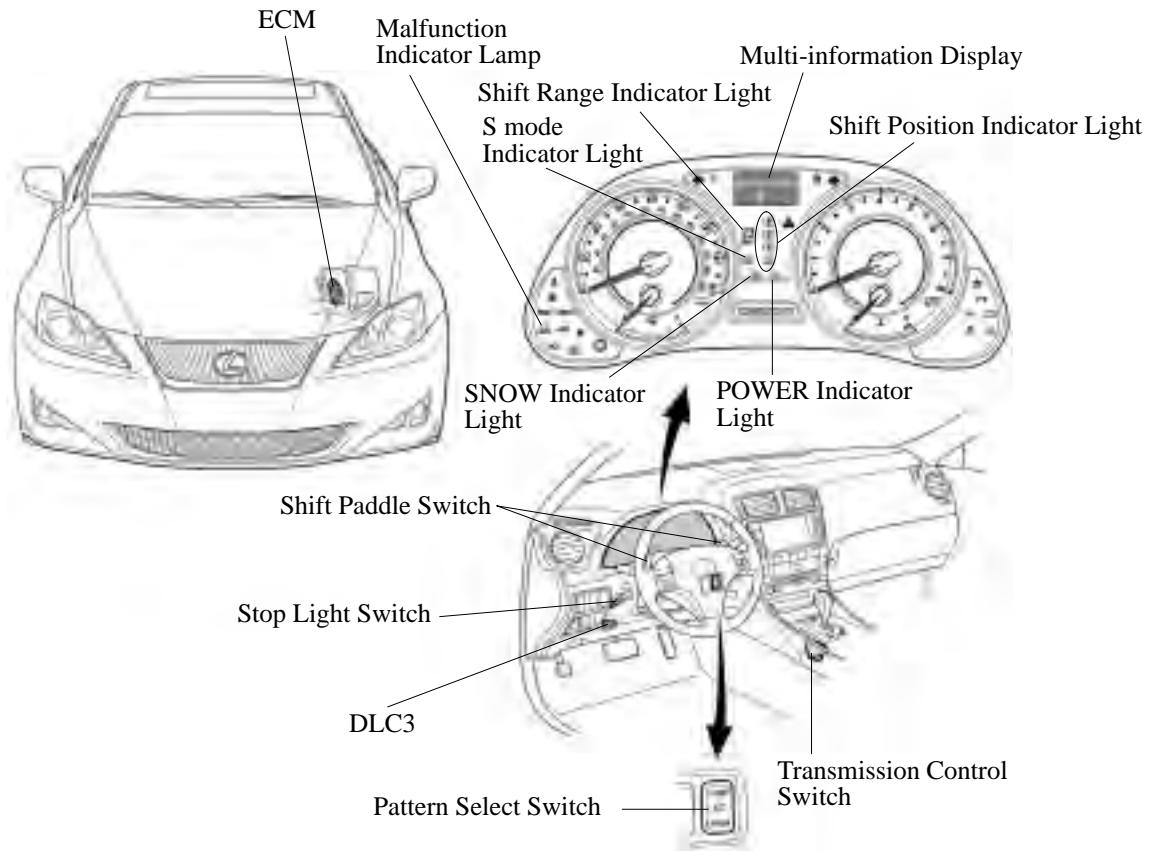

0140CH11Z

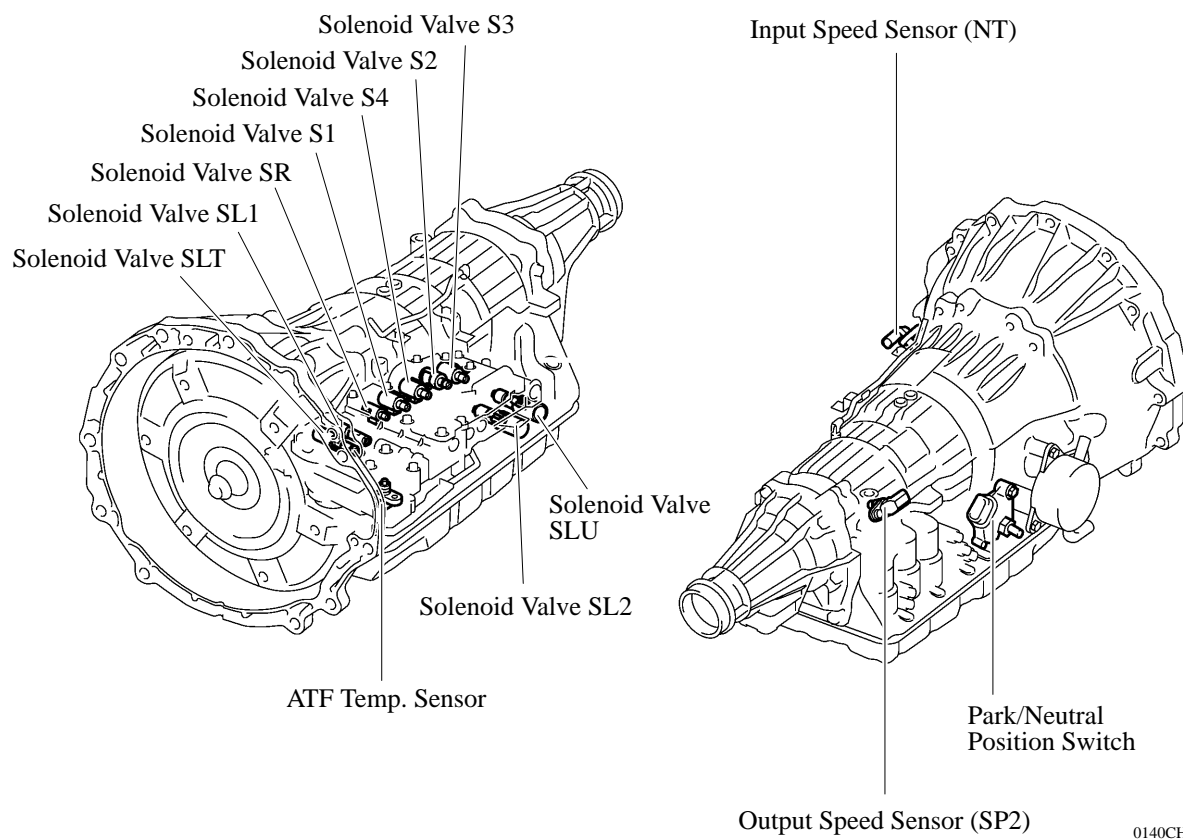

0140CH24Z

#### 4. Construction and Operation of Main Component

##### ATF Temperature Sensor

The ATF temperature sensor (OIL) is used as an input for hydraulic pressure control. This sensor is used to assist in determining the clutch and brake pressures necessary to maintain smooth shift qualities with varying temperatures of transmission fluid.

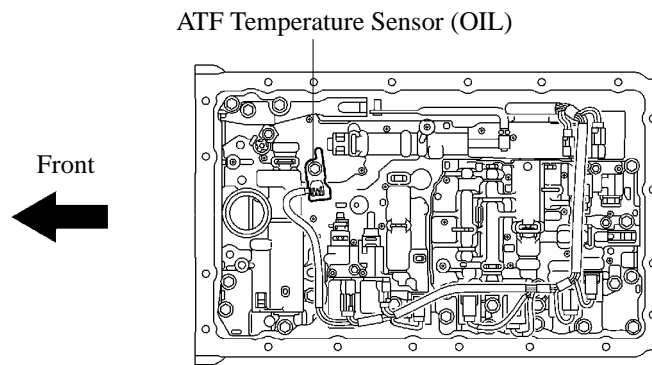

0140CH25Z

##### Input Speed Sensor and Output Speed Sensor

The A960E automatic transmission uses an input speed sensor (for NT signal) and output speed sensor (for SP2 signal). Thus, the ECM can detect the timing of the shifting of the gears and appropriately control the engine torque and hydraulic pressure in response to the various conditions.

These speed sensors are a pick-up coil type.

- The input speed sensor detects the input speed of the transmission. The C<sub>3</sub> clutch drum is used as the timing rotor for this sensor.
- The output speed sensor detects the speed of the output shaft. The parking gear on the rear planetary gear is used as the timing rotor for this sensor.

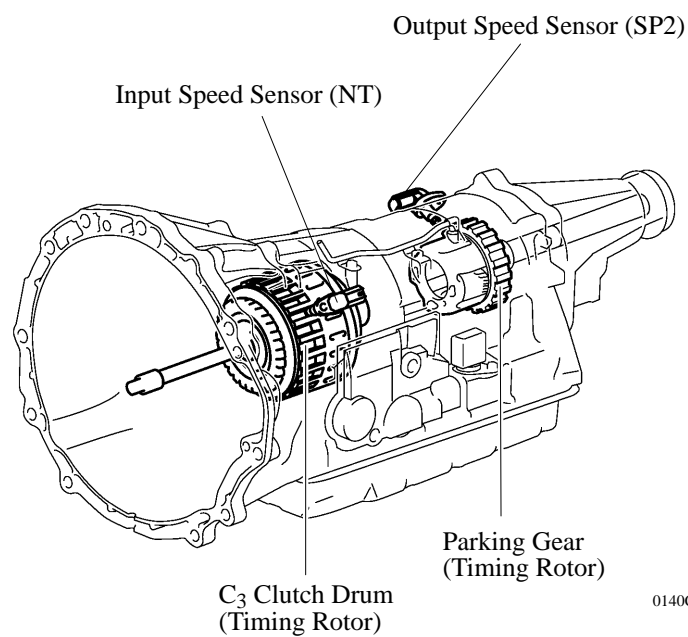

0140CH26Z

### Park/Neutral Position Switch

The park/neutral position switch sends the P, R, N, D and STAR position signals to the ECM. It also sends signals for the shift position indicator light (P, R, N, and D).

#### ► Wiring Diagram ◀

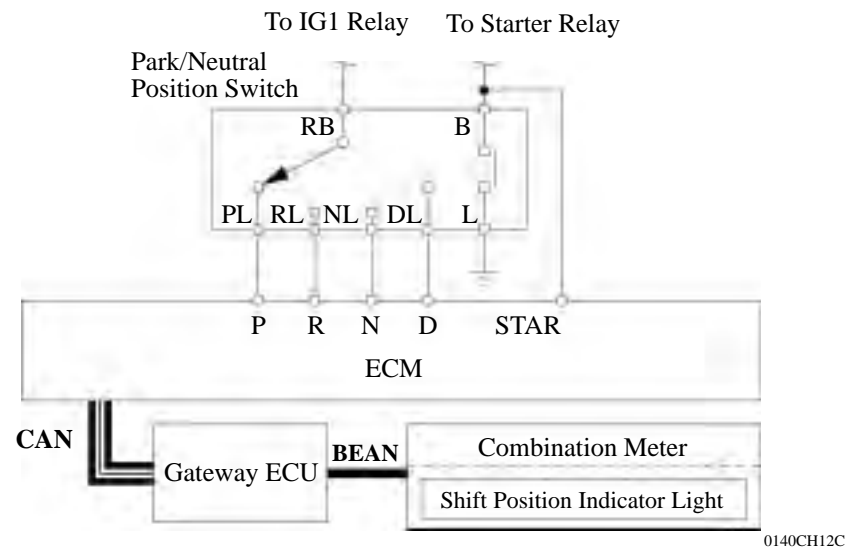

### Transmission Control Switch and Shift Paddle Switch

- The transmission control switch is installed inside the shift lever assembly to detect the shift lever position and to inform the ECM. The ECM turns on the shift position indicator light and S mode indicator light.
- The transmission control switch detects whether the shift lever is in the D position or in the S mode position, and detects the operating conditions of the shift lever (front [+ position] or rear [- position]) if the S mode is selected, and sends signals to the ECM. At this time, the ECM turns on the shift range indicator light for the selected range.
- The shift paddle switch is installed steering wheel assembly. The ECM detects the operating conditions of the shift paddle switches (right [+ position] or left [- position]) when the shift lever is in the S mode. At this time, the ECM turns on the shift range indicator light for the selected range.

#### ► Wiring Diagram ◀

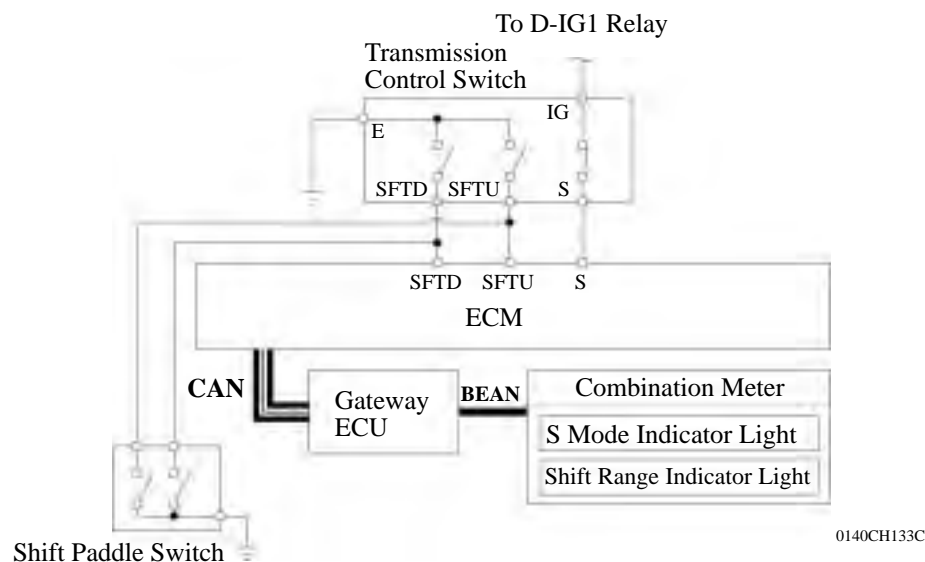

**◀ SHIFT CONTROL MECHANISM****1. General**

- ▶ A gate type shift lever is used in conjunction with the installation of the 6-speed automatic transmission. With the gate type lever, the shift lever button and the overdrive switch of the straight type shift lever are discontinued. Similar functions are achieved through a single-shift operation (fore-aft and side-to-side).
- ▶ Shift pattern is provided the S mode position on the side of the D position.
- ▶ A shift lock system is used. For details, see page CH-51.

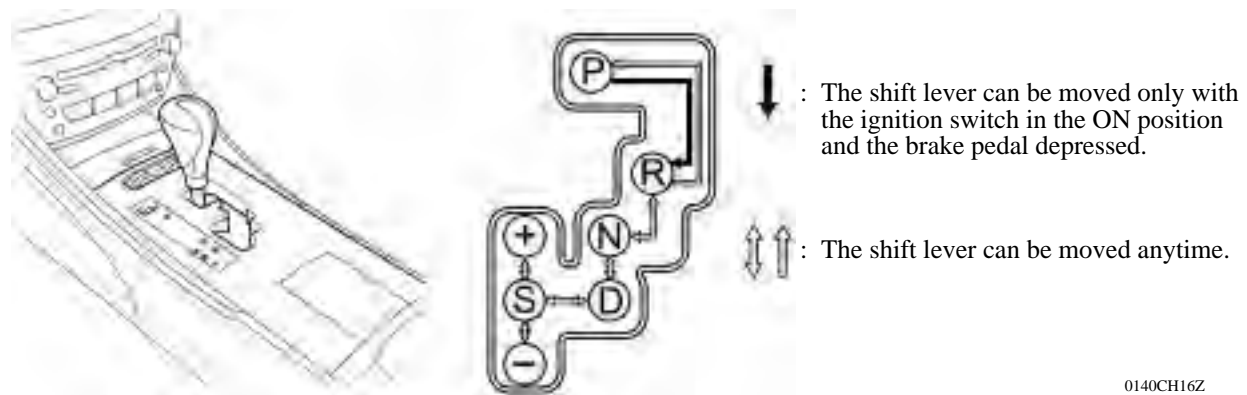

0140CH16Z



## A960E AUTOMATIC TRANSMISSION

### GENERAL

The A960E 6-speed automatic transmission [6 Super ECT (Electronic Controlled Transmission)] is used on the 4GR-FSE engine models (2WD).

- The fuel economy and driving performance have been improved by the 6-speed automatic transmission.
- The multi-mode automatic transmission with the shift paddle switch is used. For details, see page CH-45.

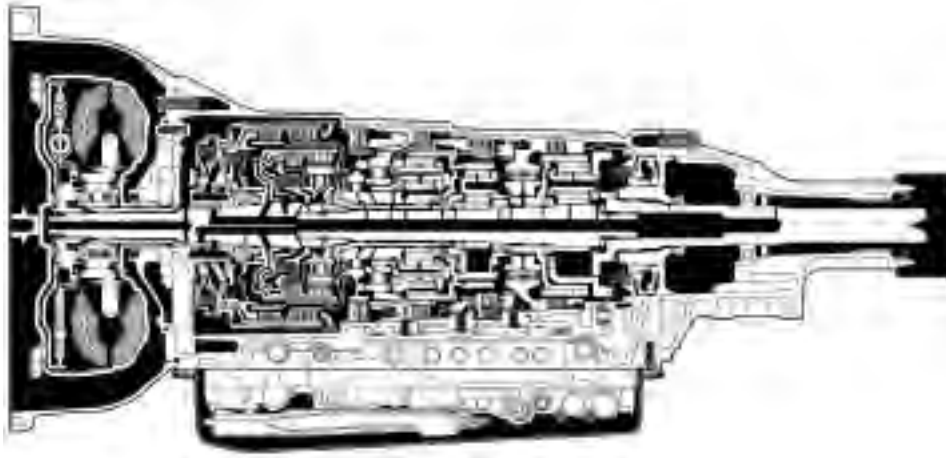

A960E Automatic Transmission

0140CH19Z

### ► Specification ◀

Transmission Type		A960E
Engine Type		4GR-FSE
Gear Ratio	1st	3.538
	2nd	2.060
	3rd	1.404
	4th	1.000
	5th	0.713
	6th	0.582
	Reverse	3.168
Fluid Capacity	Liters (US qts, Imp. qts)	7.2 (7.6, 6.3)
Fluid Type		TOYOTA Genuine ATF WS
Weight (Reference)*	kg (lb)	74.7 (164.7)

\*: Weight shows the figure with the fluid fully filled.

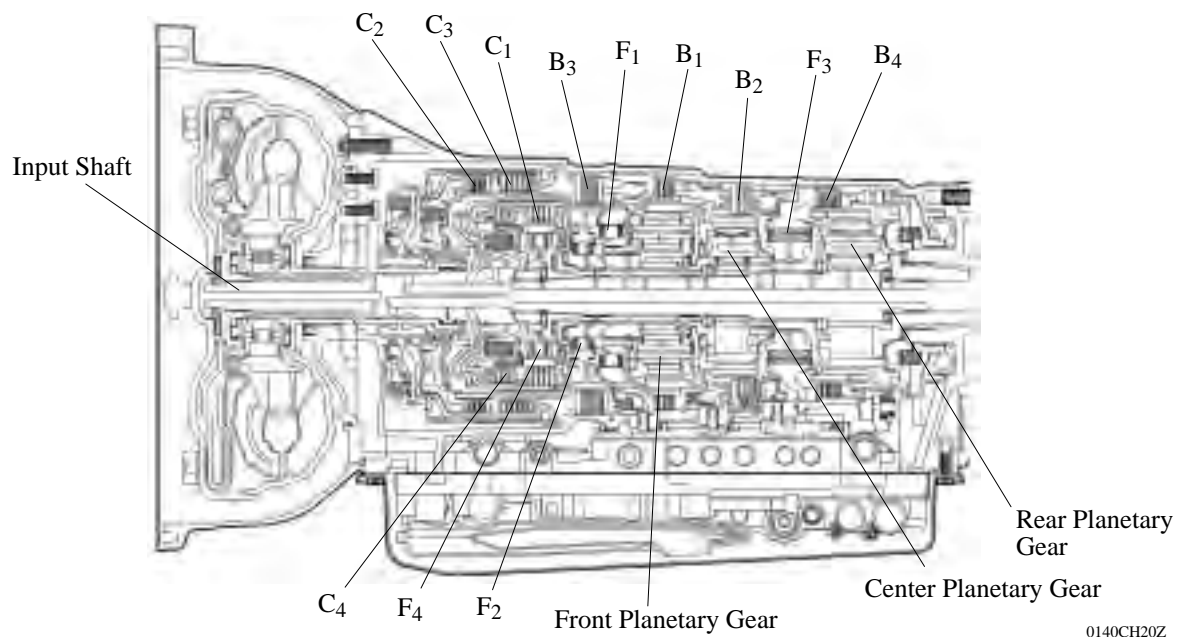

► Specification ◀

Item			A960E
C <sub>1</sub>	No.1 Clutch	The No. of Discs	4
C <sub>2</sub>	No.2 Clutch		5
C <sub>3</sub>	No.3 Clutch		4
C <sub>4</sub>	No.4 Clutch		4
B <sub>1</sub>	No.1 Brake	The No. of Sprags	3
B <sub>2</sub>	No.2 Brake		4
B <sub>3</sub>	No.3 Brake		3
B <sub>4</sub>	No.4 Brake		5
F <sub>1</sub>	No.1 One-Way Clutch	The No. of Sprags	21
F <sub>2</sub>	No.2 One-Way Clutch		22
F <sub>3</sub>	No.3 One-Way Clutch		22
F <sub>4</sub>	No.4 One-Way Clutch		25
Front Planetary Gear	The No. of Sun Gear Teeth		33
	The No. of Pinion Gear Teeth	Inner	19
		Outer	18
The No. of Ring Gear Teeth		75	
Center Planetary Gear	The No. of Sun Gear Teeth		26
	The No. of Pinion Gear Teeth		20
	The No. of Ring Gear Teeth		66
Rear Planetary Gear	The No. of Sun Gear Teeth		26
	The No. of Pinion Gear Teeth		20
	The No. of Ring Gear Teeth		66

**ATF WS**

- The ATF WS is used to reduce the resistance of the ATF and improve fuel economy by reducing its viscosity in the practical operating temperature range. At higher-fluid temperatures, the viscosity is the same as that of ATF Type T-IV, to ensure the durability of the automatic transmission.
- There is no interchangeability between the ATF WS and other types of ATF (ATF Type T-IV, D-II.)

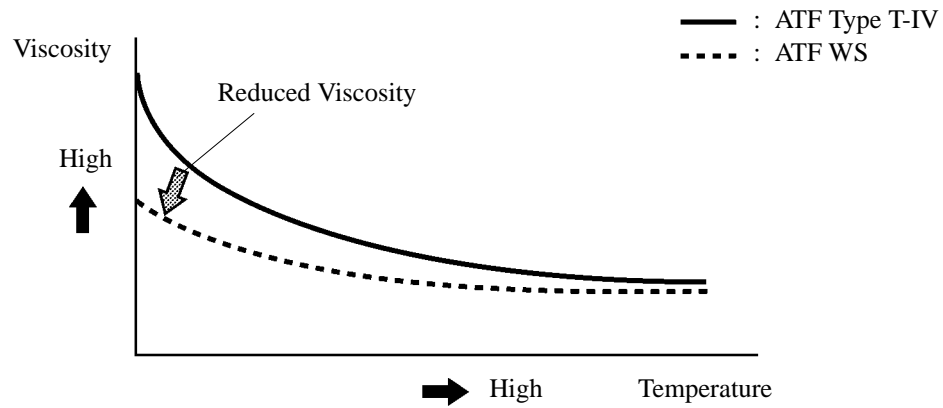

259LSK03

**Service Tip**

If a vehicle with a transmission that requires ATF WS is replenished with another type of ATF, the transmission might not engage at extremely low temperatures. However, the transmission might engage after it has been warmed up for a few minutes.

**TORQUE CONVERTER**

A compact, lightweight and high-capacity torque converter is used. The torque converter supports flex lock-up clutch control, thus improving fuel economy.

► **Specification** ◀

Type	3-Element, 1-Step, 2-Phase
Stall Torque Ratio	1.95

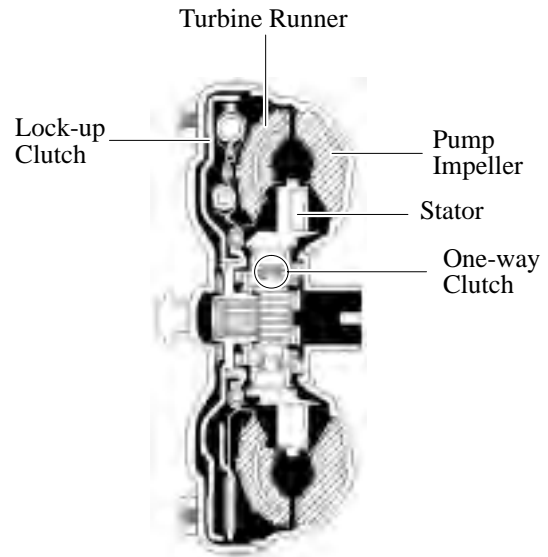

0140CH27Z

**OIL PUMP**

The oil pump is operated by the torque converter. It lubricates the planetary gear units and supplies operating fluid pressure for hydraulic control.

The material of the pump cover is aluminum to reduce weight.

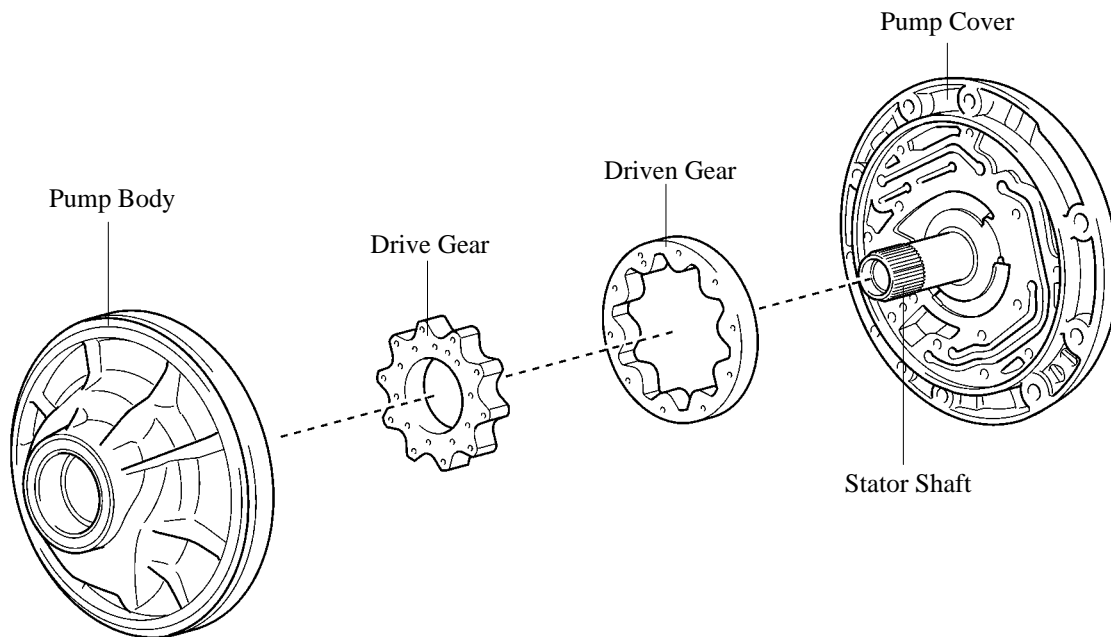

232CH89

## OIL STRAINER

A felt type oil strainer (in a plastic case) is used because it weighs less, offers excellent debris capturing ability, and is more reliable. This oil strainer is maintenance-free.

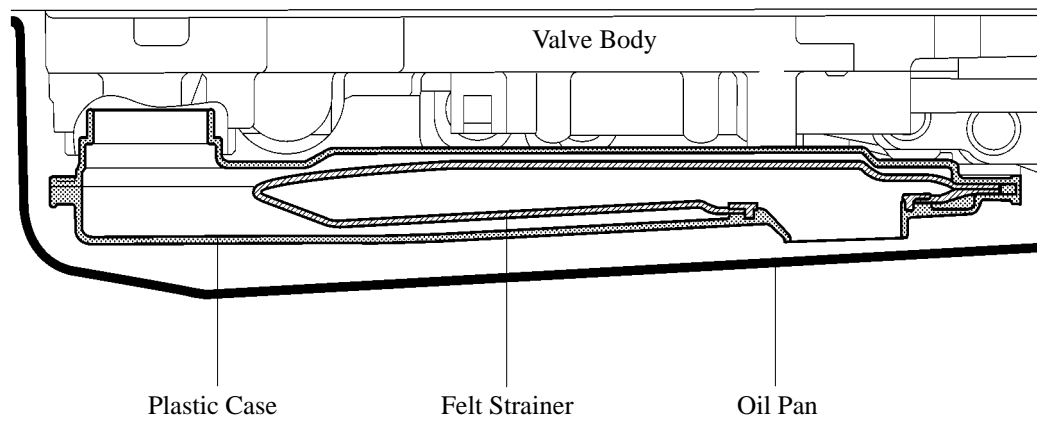

0140CH138Y

## ATF FILLING PROCEDURES

The ATF filling procedure is changed in order to improve the accuracy of the ATF level when the transmission is being repaired or replaced. As a result, the oil filler tube and the oil level gauge used for a conventional automatic transmission are discontinued, eliminating the need to inspect the fluid level as a part of routine maintenance.

- This filling procedure uses a refill plug, overflow plug, ATF temperature sensor, and shift indicator light "D".

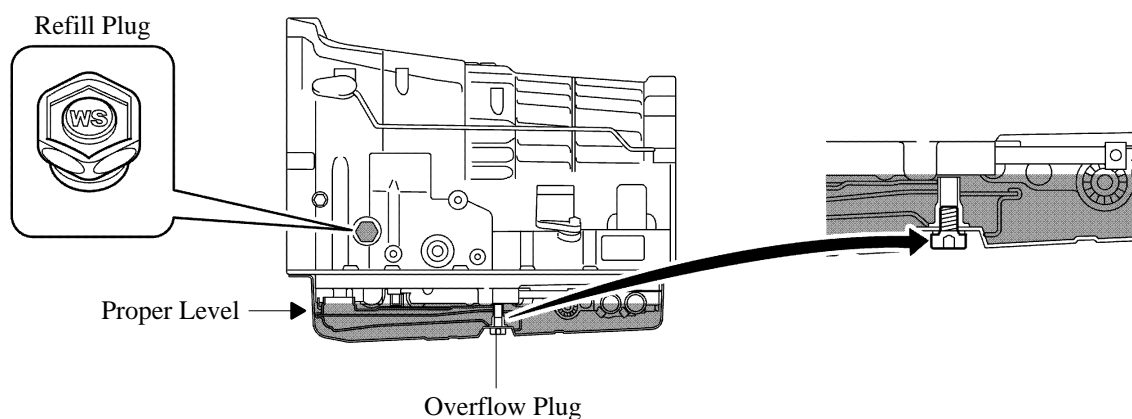

0140CH21Z

**Service Tip**

**ATF Filling procedure using SST (09843-18040)**

When a large amount of ATF needs to be filled (i. e. after removal and installation of oil pan or torque converter), perform the procedure from step 1.

When a small amount of ATF is required (i. e. removal and installation of oil cooler tube, repair of a minor oil leak), perform the procedure from step 7.

- 1) Raise the vehicle while keeping it level.
- 2) Remove the refill plug and overflow plug.
- 3) Fill the transmission with WS type ATF from the refill plug hole until it overflows from the overflow plug hole.
  - The fluid used to fill the transmission should be ATF WS.
- 4) Install the overflow plug.
- 5) Add the specified amount of ATF (specified amount is determined by the procedure that was performed) and install the refill plug.

**Example:**

Procedure	Liters (US qts, Imp.qts)
Removal and installation of transmission oil pan (including oil drainage)	1.0 (1.06, 0.88)
Removal and installation of transmission valve body	2.2 (2.33, 1.94)
Replacement of torque converter	3.7 (3.91, 3.26)

- 6) Lower the vehicle.
- 7) Use the SST (09843-18040) to short the TC, OPB, and CG terminals of the DLC3 connector:
- 8) Start the engine and allow it to idle.
  - A/C switch must be turned off.
- 9) Move the shift lever from the P position to the S mode position and slowly select each gear S1 - S6. Then move the shift lever back to the P position.

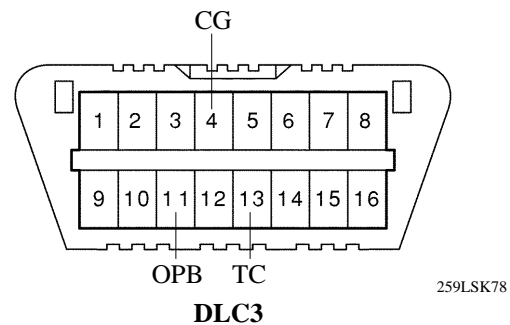

- 10) Move the shift lever to the D position, and quickly move then back and forth between N and D (at least once every 1.5 seconds) for at least six seconds. This will activate the oil temperature detection mode.
 

**Standard: The shift position indicator light “D” will remain illuminated for 2 seconds and then go off.**

- 11) Return the shift lever to the P position and disconnect the TC terminal.
  - Do not disconnect the SST from terminals OPB and CG of DLC3 until the procedure is finished.
- 12) Idle the engine to raise the transmission fluid temperature.
- 13) Immediately after the shift position indicator light “D” light turns on, lift the vehicle up.
  - The shift position indicator light “D” will indicate the ATF temperature according to the following table. (Insert table here)

ATF Temp.	Less than Optimized Temp.	Optimized Temp.	More than Optimized Temp.
Shift Position Indicator Light “D”	Turn OFF	Turn ON	Blinking

(Continued)

- 14) Remove the overflow plug and adjust oil quantity.
  - If the ATF overflows, go to step 17, and if the ATF does not overflow, go to step 15.
- 15) Remove the refill plug.
- 16) Add ATF to the refill plug hole until it flows out from the overflow plug hole.
- 17) When the ATF flow slows to a trickle, install the overflow plug and a new gasket.
- 18) Install the refill plug (if the refill plug was removed).
- 19) Lower the vehicle down.
- 20) Turn the ignition switch OFF to stop the engine.

For details about ATF Filling procedures, see the 2006 LEXUS IS350/250 Repair Manual (Pub. No. RM0140U).

## ATF WARMER

### General

An ATF warmer is used for the purpose of warming up the ATF quickly and to keep the ATF temperature higher (within limits). As a result, fuel economy has been improved.

#### ► Layout of Component ◀

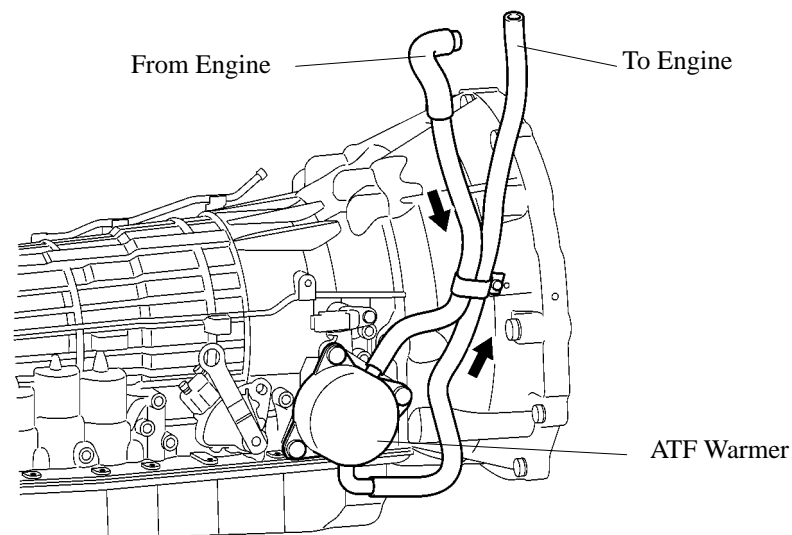

281CH13

### Operation

#### 1) During warm-up

The engine coolant flows directly from the engine to the ATF warmer in order to warm up the ATF quickly even before the engine thermostat opens. Consequently, the friction losses of the automatic transmission are quickly reduced, thus improving fuel economy.

#### 2) After warm-up

The engine coolant that flows through the ATF warmer will help to limit the ATF temperature increase.

**PLANETARY GEAR UNIT**

**1. Construction**

The planetary gear unit consists of three planetary gear units, four clutches, four brakes, and four one-way clutches.

- A centrifugal fluid pressure canceling mechanism is used in the C<sub>1</sub>, C<sub>2</sub>, C<sub>3</sub>, and C<sub>4</sub> clutches that are applied when shifting 2nd → 3rd, 3rd → 4th, 4th → 5th, and 5th → 6th. For details, refer to page CH-66.

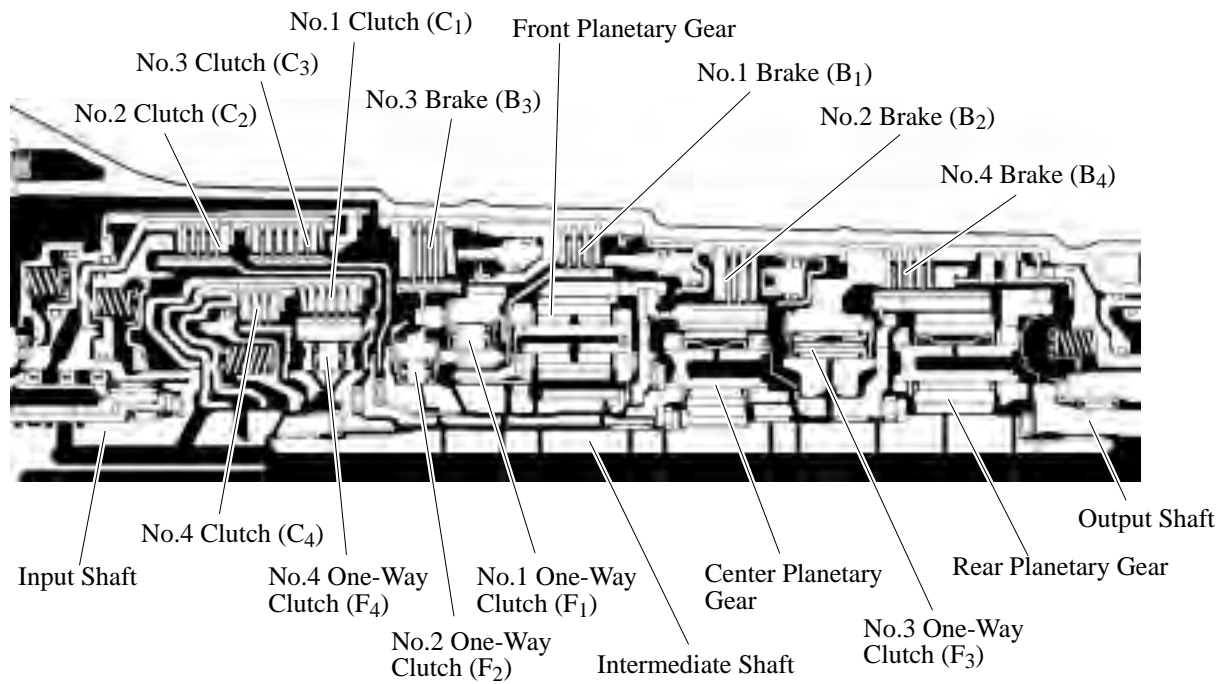

0140CH22Z

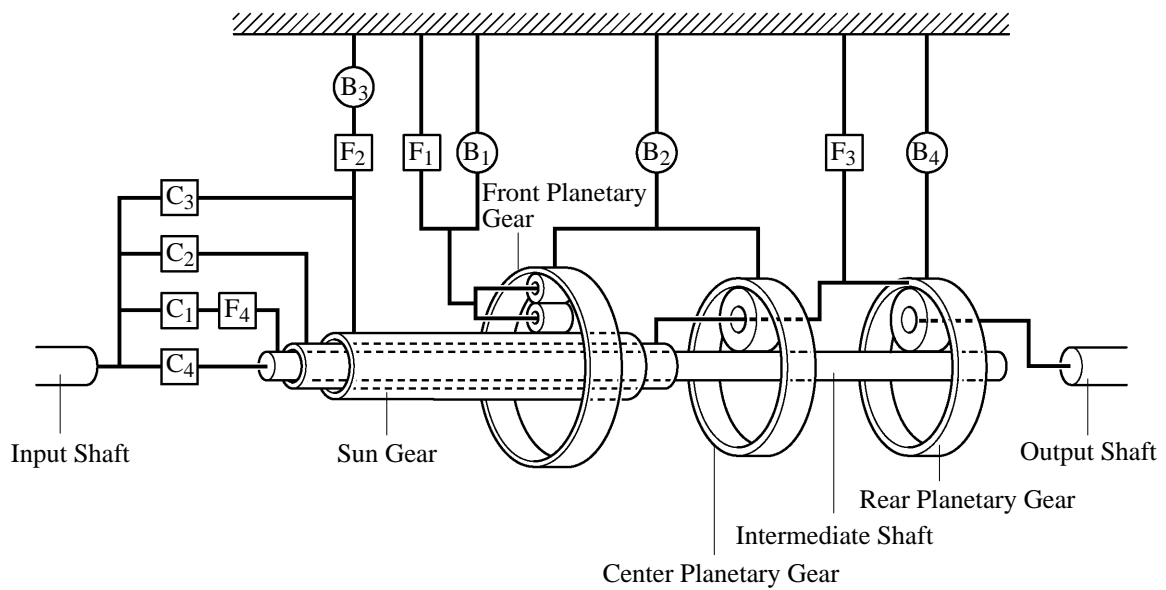

259LSK08



## 2. Function of Component

Component		Function
C <sub>1</sub>	No.1 Clutch	Connects the input shaft, F <sub>4</sub> and intermediate shaft.
C <sub>2</sub>	No.2 Clutch	Connects the input shaft and center planetary carrier.
C <sub>3</sub>	No.3 Clutch	Connects the input shaft and sun gear.
C <sub>4</sub>	No.4 Clutch	Connects the input shaft and intermediate shaft.
B <sub>1</sub>	No.1 Brake	Prevents the front planetary carrier from turning either clockwise or counterclockwise.
B <sub>2</sub>	No.2 Brake	Prevents the front and the center ring gear from turning either clockwise or counterclockwise.
B <sub>3</sub>	No.3 Brake	Prevents outer race of F <sub>2</sub> from turning both clockwise and counterclockwise.
B <sub>4</sub>	No.4 Brake	Prevents center planetary carrier and the rear ring gear from turning either clockwise or counterclockwise.
F <sub>1</sub>	No.1 One-Way Clutch	Prevents the front planetary carrier from turning counterclockwise.
F <sub>2</sub>	No.2 One-Way Clutch	When B <sub>3</sub> is operating, the one way clutch prevents the front sun gear from turning counterclockwise.
F <sub>3</sub>	No.3 One-Way Clutch	Prevents the center planetary carrier and the rear ring gear from turning counterclockwise.
F <sub>4</sub>	No.4 One-Way Clutch	Prevents the intermediate shaft from turning counterclockwise.
Planetary Gears		These gears change the route through which driving force is transmitted, in accordance with the operation of each clutch and brake, in order to increase or reduce the output shaft speed.

3. Transmission Power Flow

Shift Lever Position	Solenoid Valve								Clutch				Brake				One-way Clutch				
	S1	S2	S3	S4	SR	SL1	SL2	SLU	C <sub>1</sub>	C <sub>2</sub>	C <sub>3</sub>	C <sub>4</sub>	B <sub>1</sub>	B <sub>2</sub>	B <sub>3</sub>	B <sub>4</sub>	F <sub>1</sub>	F <sub>2</sub>	F <sub>3</sub>	F <sub>4</sub>	
P		ON	ON		ON		ON														
R*		ON	ON		ON		ON				○		○			○	○				
N		ON	ON		ON		ON														
D, S6	1st		ON	ON		ON		ON	○			○							○	○	
	2nd	ON	ON	ON		ON		ON	ON	○		○			○		○	○			○
	3rd	ON		ON		ON		ON	ON	○		○	○		●		○				○
	4th*	ON				ON		ON	ON	○	○	●	○		●						○
	5th*	ON			ON		ON		ON	●	○	○		○		●					
	6th*	ON	ON		ON		ON		ON	●	○			●	○	●					
S5	1st		ON	ON		ON		ON	○			○							○	○	
	2nd	ON	ON	ON		ON		ON	ON	○		○			○		○	○			○
	3rd	ON		ON		ON		ON	ON	○		○	○		●		○				○
	4th*	ON				ON		ON	ON	○	○	●	○		●						○
	5th*	ON			ON		ON		ON	●	○	○		○		●					
S4	1st		ON	ON		ON		ON	○			○							○	○	
	2nd	ON	ON	ON		ON		ON	ON	○		○			○		○	○			○
	3rd	ON		ON		ON		ON	ON	○		○	○		●		○				○
	4th*	ON				ON		ON	ON	○	○	●	○		●						○
S3	1st		ON	ON		ON		ON	○			○							○	○	
	2nd	ON	ON	ON		ON		ON	○			○			○		○	○			○
	3rd*	ON		ON		ON			○		○	○	(○)		●		○				○
S2	1st		ON	ON		ON		ON	○			○							○	○	
	2nd*	ON	ON	ON	ON	ON			○			○		(○)	○		○	○			○
S1	1st*		ON	ON		ON			○			○				(○)			○	○	

○: Operation    ●: Operate but is not related to power transmission  
 (○): Operation during engine braking    \*: with Engine Brake

**1st Gear (D Position or S Mode)**

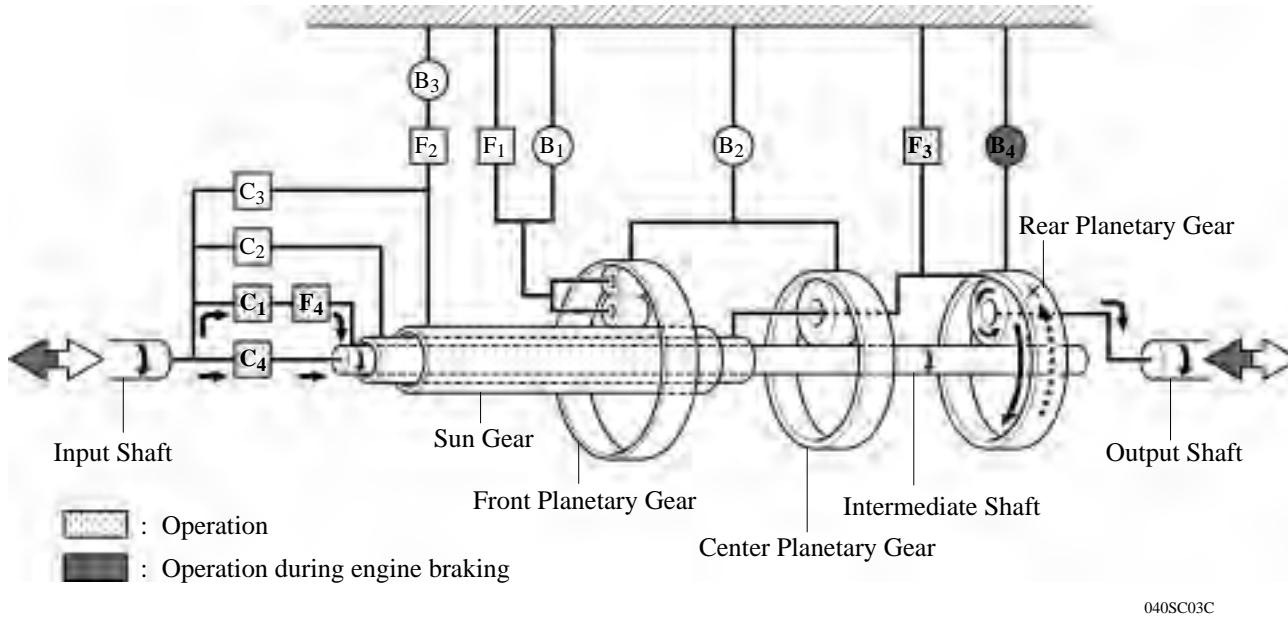

C <sub>1</sub>	C <sub>2</sub>	C <sub>3</sub>	C <sub>4</sub>	B <sub>1</sub>	B <sub>2</sub>	B <sub>3</sub>	B <sub>4</sub>	F <sub>1</sub>	F <sub>2</sub>	F <sub>3</sub>	F <sub>4</sub>
○			○				(○)			○	○

○: Operation (○): Operation during engine braking (only in the S mode [1st])

**2nd Gear (D Position or S Mode)**

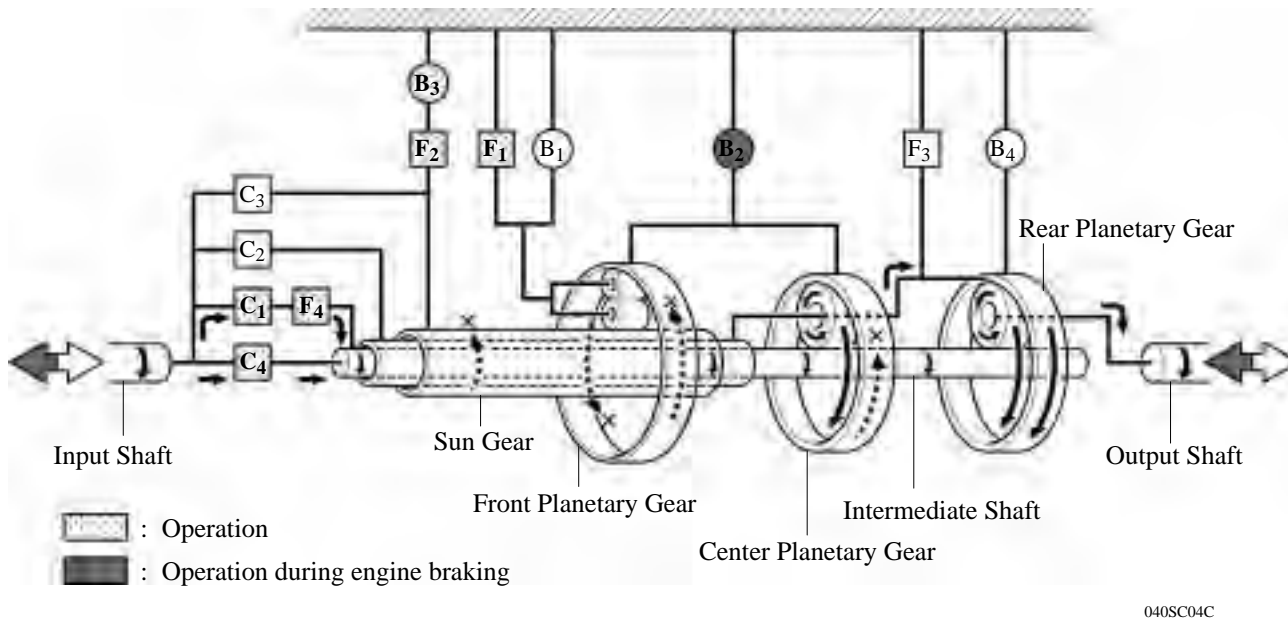

C <sub>1</sub>	C <sub>2</sub>	C <sub>3</sub>	C <sub>4</sub>	B <sub>1</sub>	B <sub>2</sub>	B <sub>3</sub>	B <sub>4</sub>	F <sub>1</sub>	F <sub>2</sub>	F <sub>3</sub>	F <sub>4</sub>
○			○		(○)	○		○	○		○

○: Operation (○): Operation during engine braking (only in the S mode [2nd])

**3rd Gear (D Position or S Mode)**

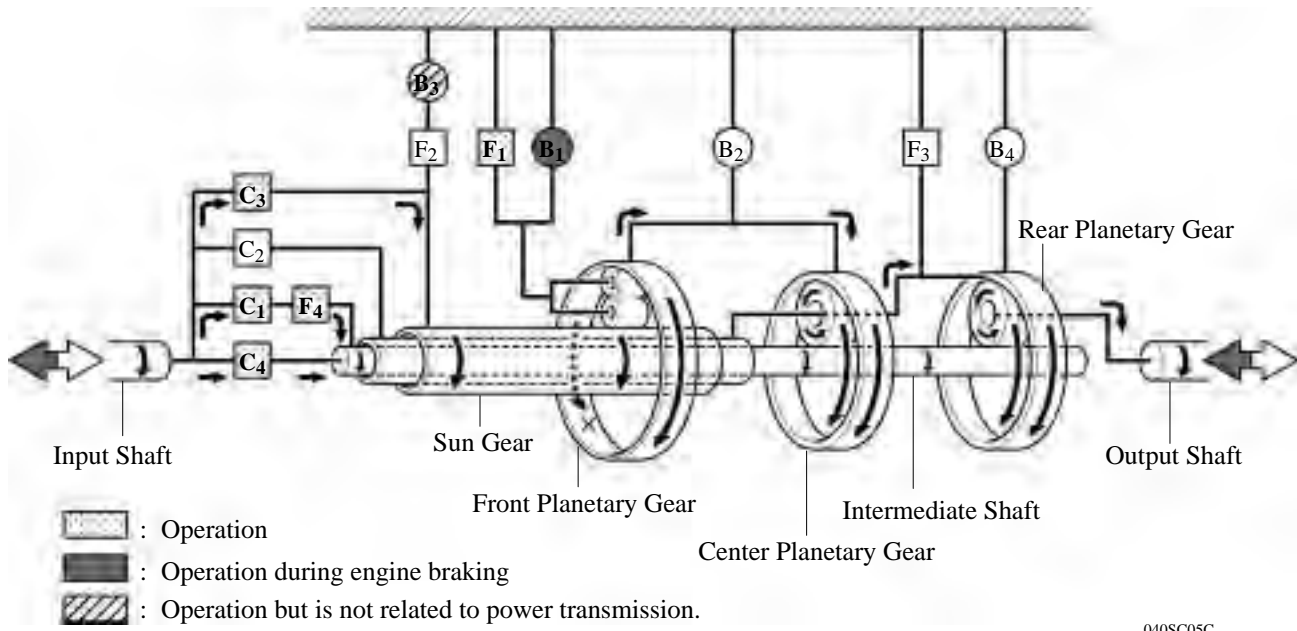

040SC05C

C <sub>1</sub>	C <sub>2</sub>	C <sub>3</sub>	C <sub>4</sub>	B <sub>1</sub>	B <sub>2</sub>	B <sub>3</sub>	B <sub>4</sub>	F <sub>1</sub>	F <sub>2</sub>	F <sub>3</sub>	F <sub>4</sub>
○		○	○	(○)		Δ		○			○

○: Operation (○): Operation during engine braking (only in the S mode [3rd])  
 Δ: Operation but is not related to power transmission

**4th Gear (D Position or S Mode)**

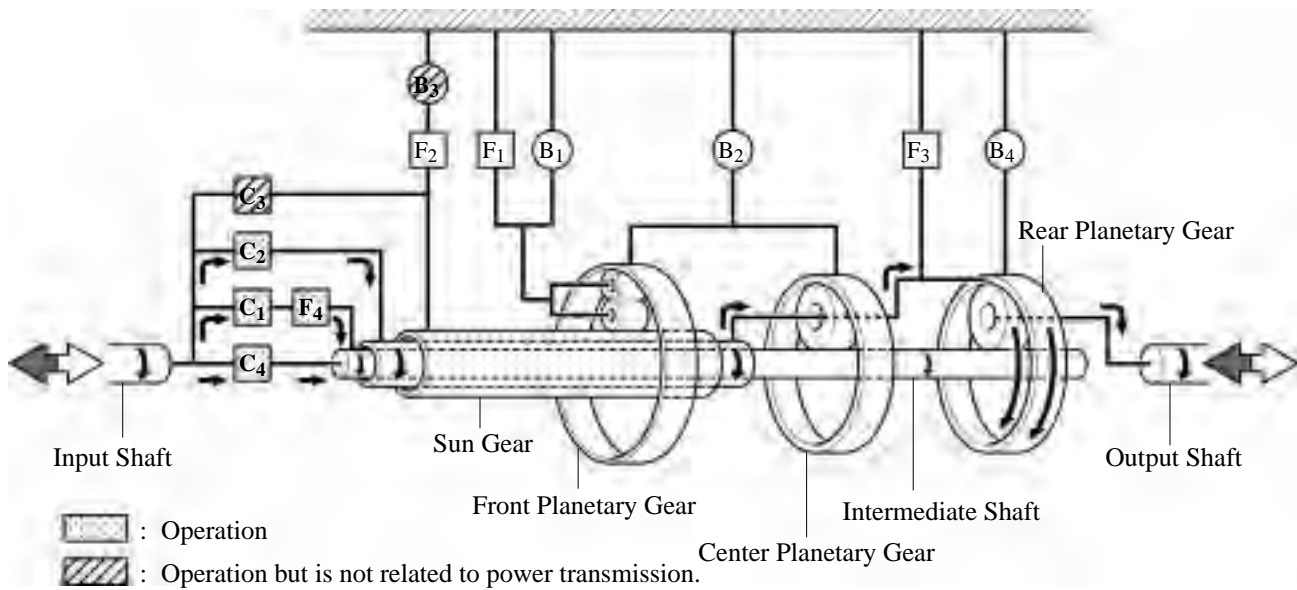

040SC06C

C <sub>1</sub>	C <sub>2</sub>	C <sub>3</sub>	C <sub>4</sub>	B <sub>1</sub>	B <sub>2</sub>	B <sub>3</sub>	B <sub>4</sub>	F <sub>1</sub>	F <sub>2</sub>	F <sub>3</sub>	F <sub>4</sub>
○	○	Δ	○			Δ					○

○: Operation Δ: Operation but is not related to power transmission

**5th Gear (D Position or S Mode)**

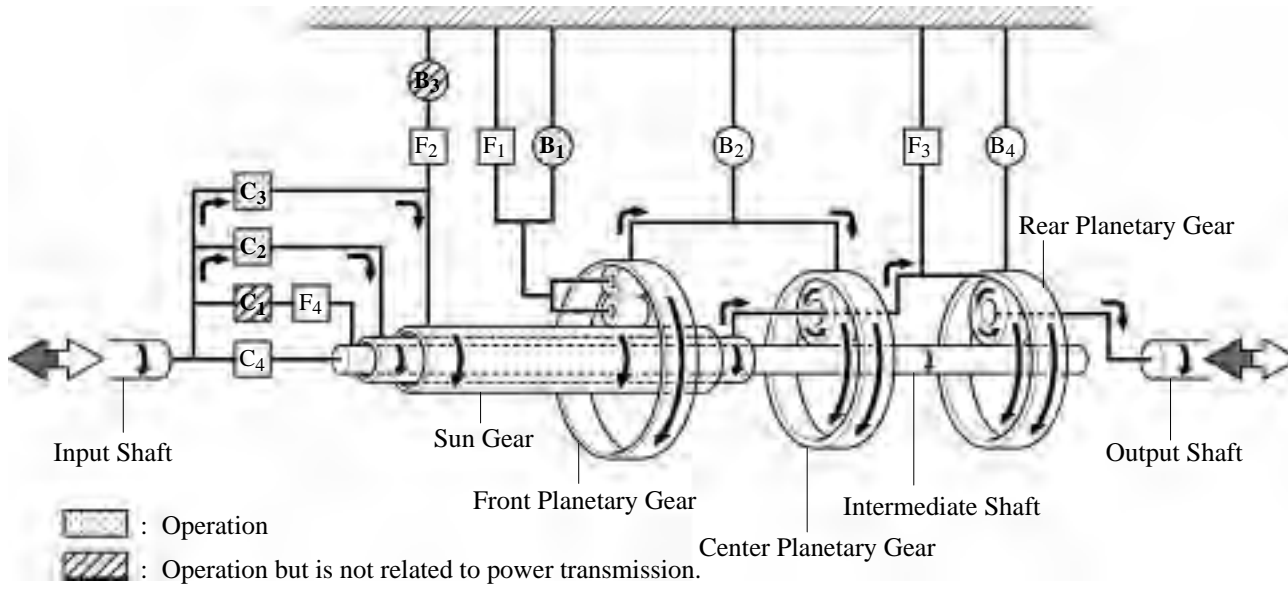

040SC07C

C <sub>1</sub>	C <sub>2</sub>	C <sub>3</sub>	C <sub>4</sub>	B <sub>1</sub>	B <sub>2</sub>	B <sub>3</sub>	B <sub>4</sub>	F <sub>1</sub>	F <sub>2</sub>	F <sub>3</sub>	F <sub>4</sub>
Δ	○	○		○		Δ					

○: Operation    Δ: Operation but is not related to power transmission

**6th Gear (D Position or S Mode)**

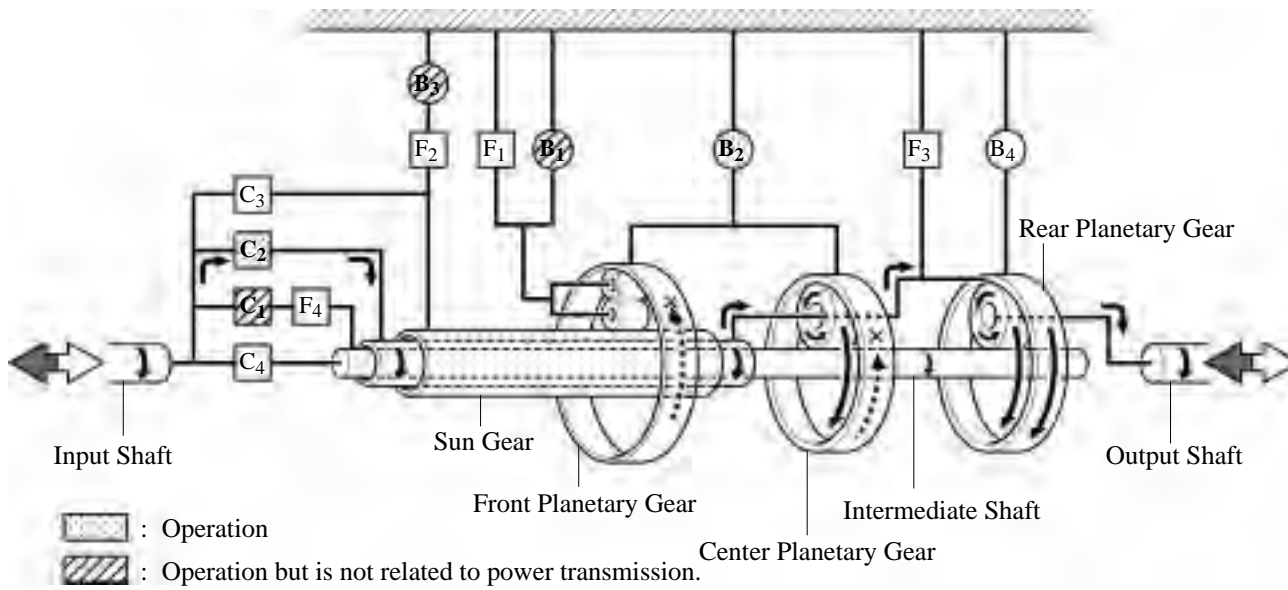

040SC08C

C <sub>1</sub>	C <sub>2</sub>	C <sub>3</sub>	C <sub>4</sub>	B <sub>1</sub>	B <sub>2</sub>	B <sub>3</sub>	B <sub>4</sub>	F <sub>1</sub>	F <sub>2</sub>	F <sub>3</sub>	F <sub>4</sub>
Δ	○			Δ	○	Δ					

○: Operation    Δ: Operation but is not related to power transmission

Reverse (R Position)

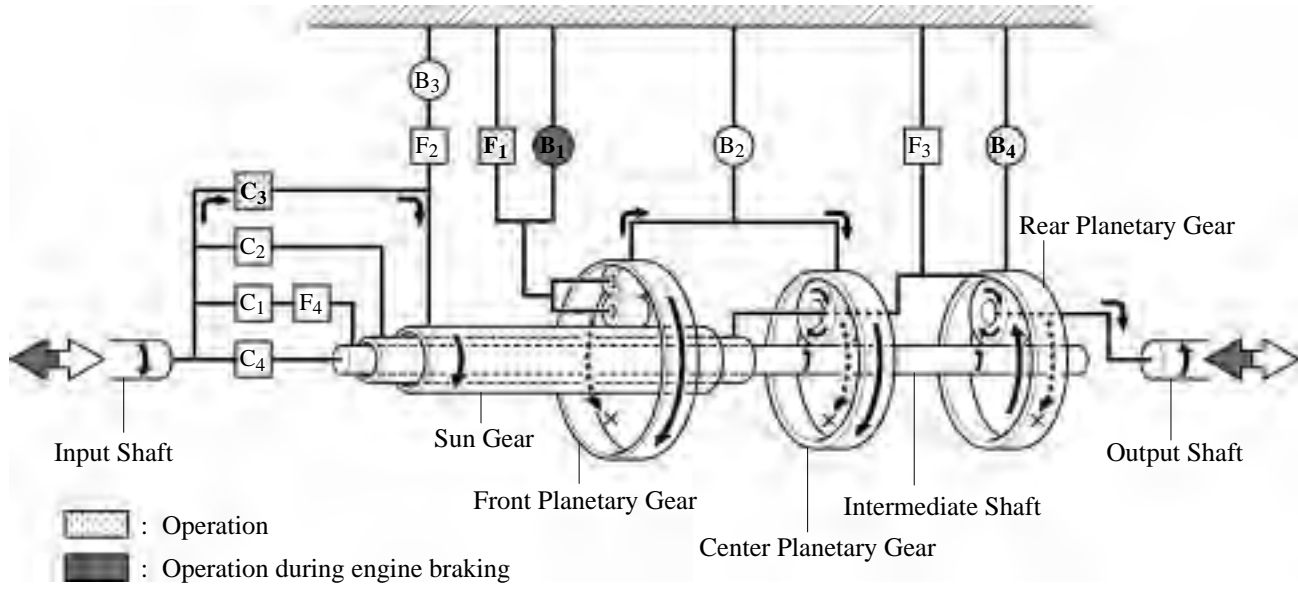

C <sub>1</sub>	C <sub>2</sub>	C <sub>3</sub>	C <sub>4</sub>	B <sub>1</sub>	B <sub>2</sub>	B <sub>3</sub>	B <sub>4</sub>	F <sub>1</sub>	F <sub>2</sub>	F <sub>3</sub>	F <sub>4</sub>
		○		(○)			○	○			

○: Operation    (○): Operation during engine braking

**4. Centrifugal Fluid Pressure Canceling Mechanism**

For the following reason, the centrifugal fluid pressure canceling mechanism is used on C<sub>1</sub>, C<sub>2</sub>, C<sub>3</sub>, and C<sub>4</sub> clutch.

- Clutch shifting operation is affected not only by the valve body controlling fluid pressure but also by centrifugal fluid pressure that is present due to fluid in the clutch piston oil pressure chamber. The centrifugal fluid pressure canceling mechanism has chamber B to reduce this affect applied to the chamber A. As a result, smooth shifting with excellent response has been achieved.

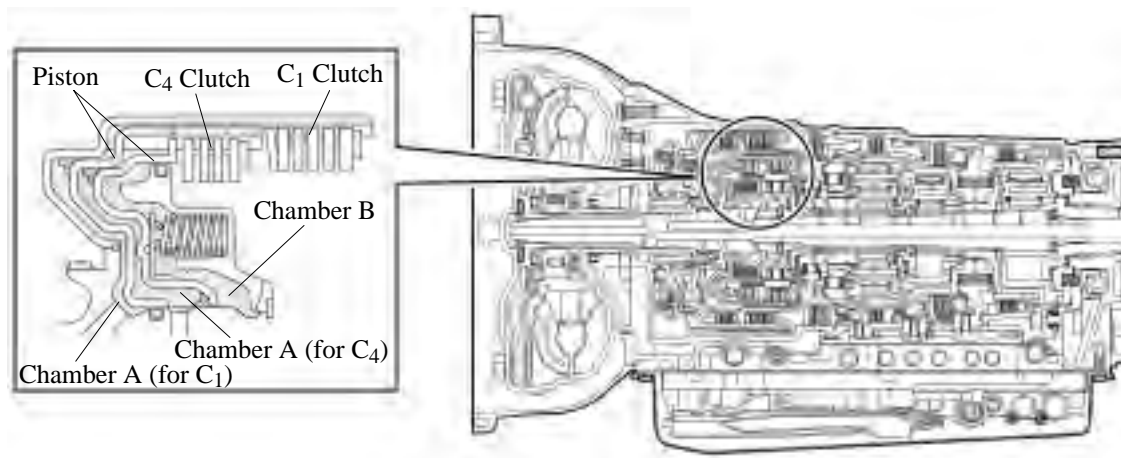

0140CH23Z

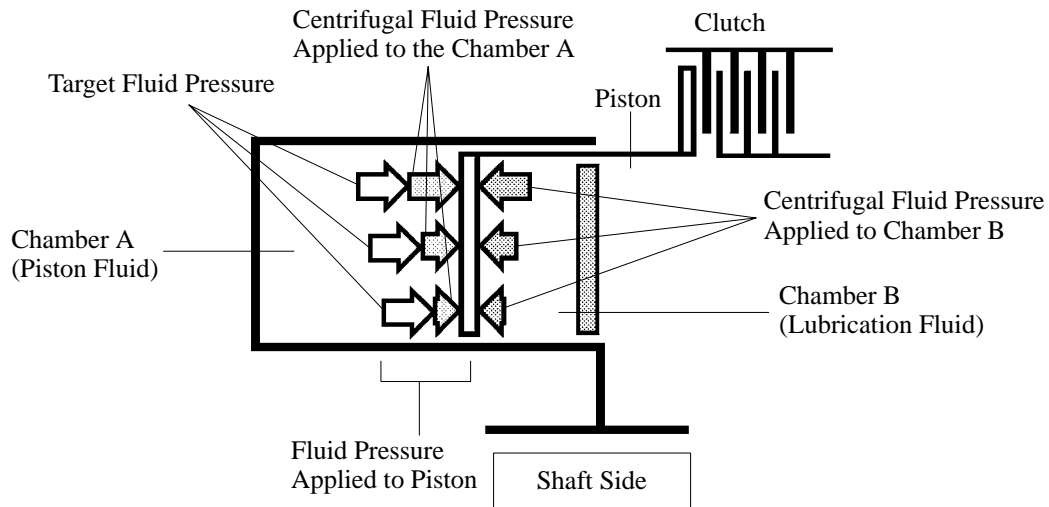

157CH17

Fluid pressure applied to piston	—	Centrifugal fluid pressure applied to chamber B	=	Target fluid pressure (original clutch pressure)
----------------------------------	---	---	---	--

**VALVE BODY UNIT**

**1. General**

The valve body consists of the upper (No.1 and No.2) and lower (No.1 and No.2) valve bodies and 9 solenoid valves.

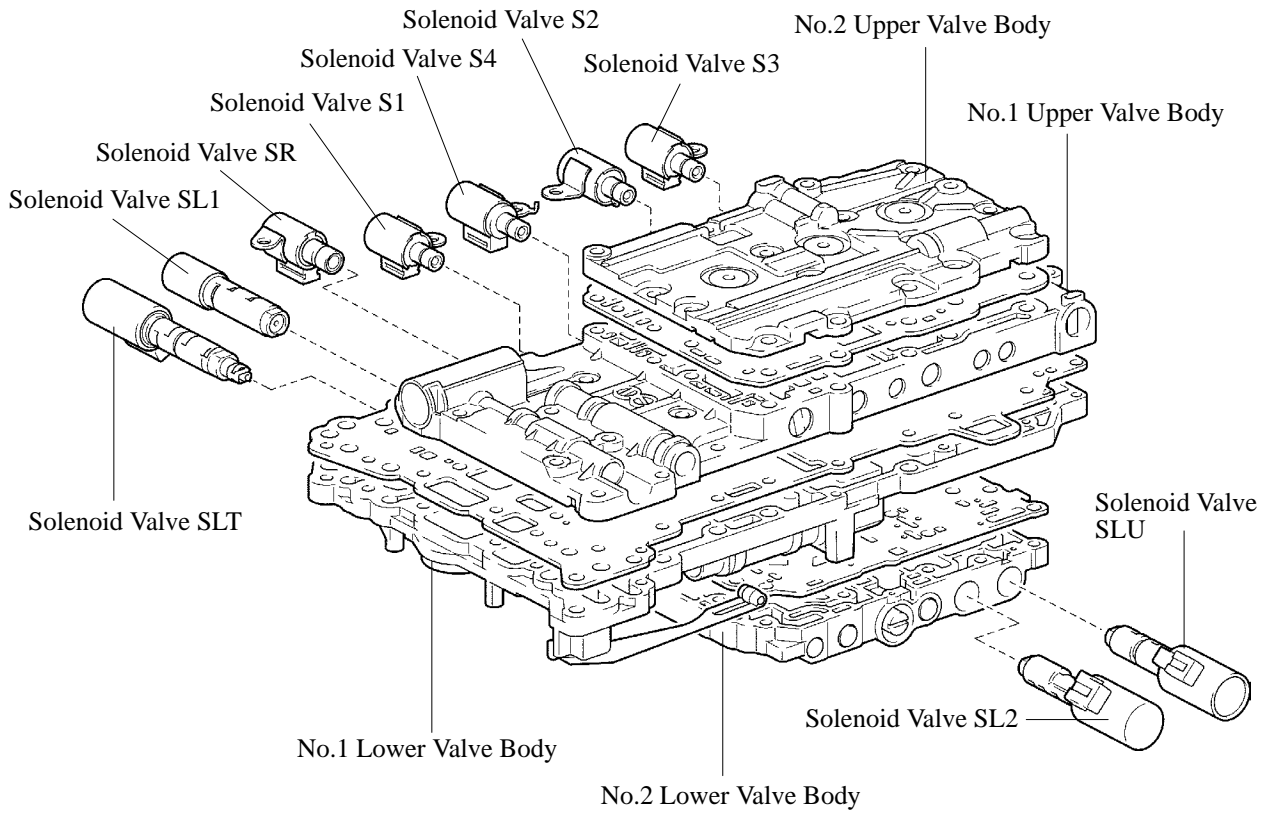

259LSK76

► **No.1 Upper Valve Body** ◀

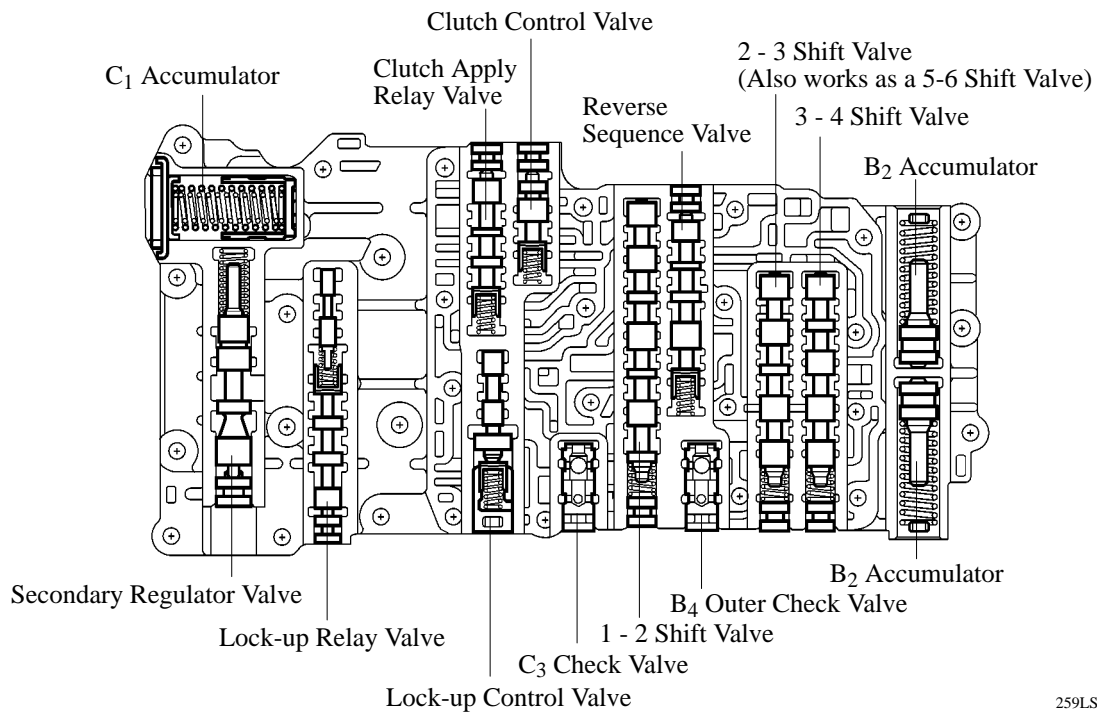

259LSK74



► No.2 Upper Valve Body ◀

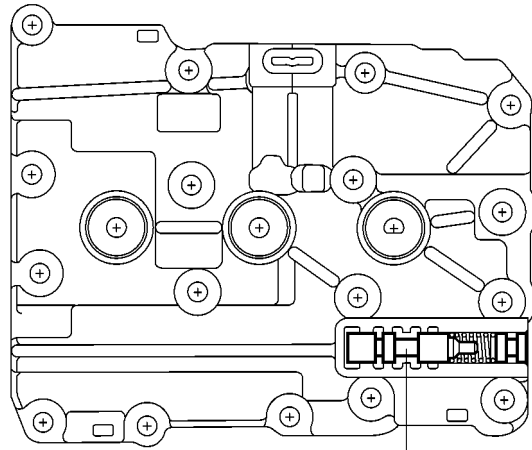

C<sub>3</sub> Apply Relay Valve

259LSK72

► No.1 Lower Valve Body ◀

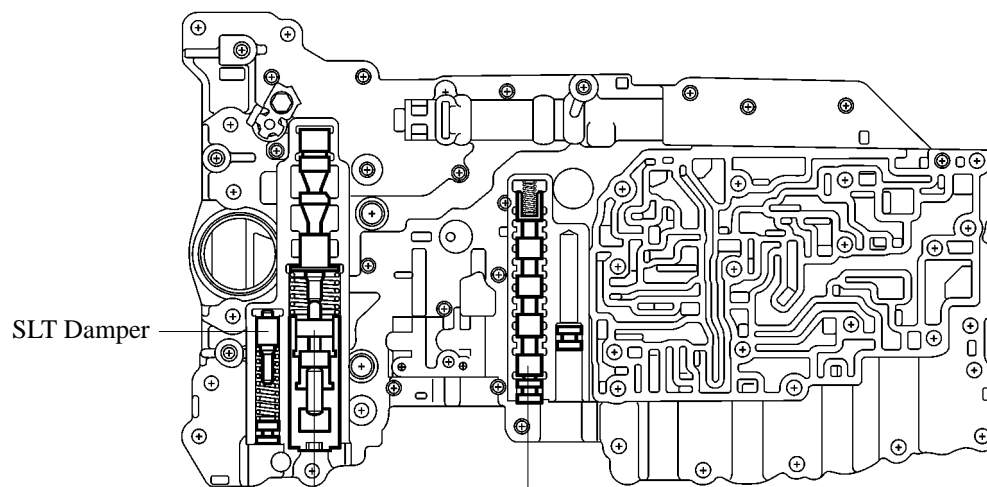

SLT Damper

4 - 5 Shift Valve

Primary Regulator Valve

259LSK73

► No.2 Lower Valve Body ◀

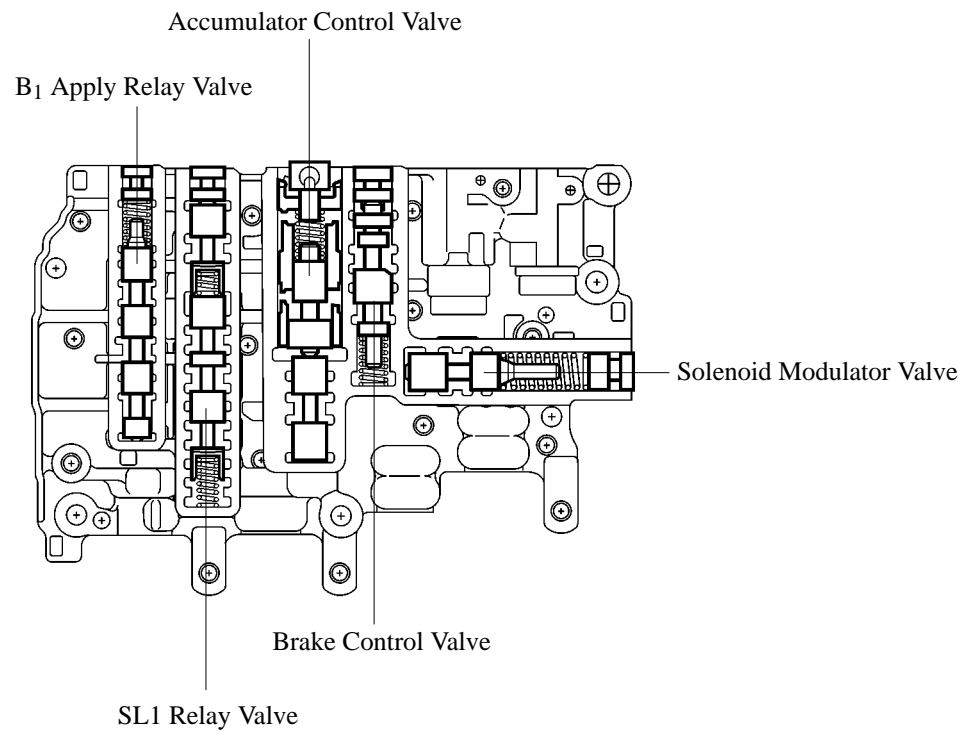

**2. Solenoid Valve**

**Solenoid Valve S1, S2, S3, S4 and SR**

**1) General**

These solenoid valves are 3-way solenoid valves. A filter is provided at the tip of the solenoid valve to further improve operational reliability.

**► Solenoid Valve S1, S2, S3 and SR ◀**

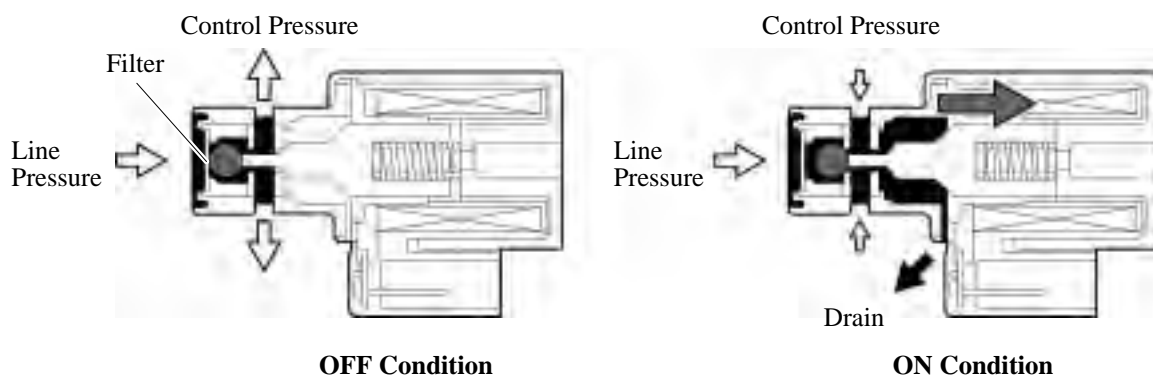

040SC10C

**► Solenoid Valve S4 ◀**

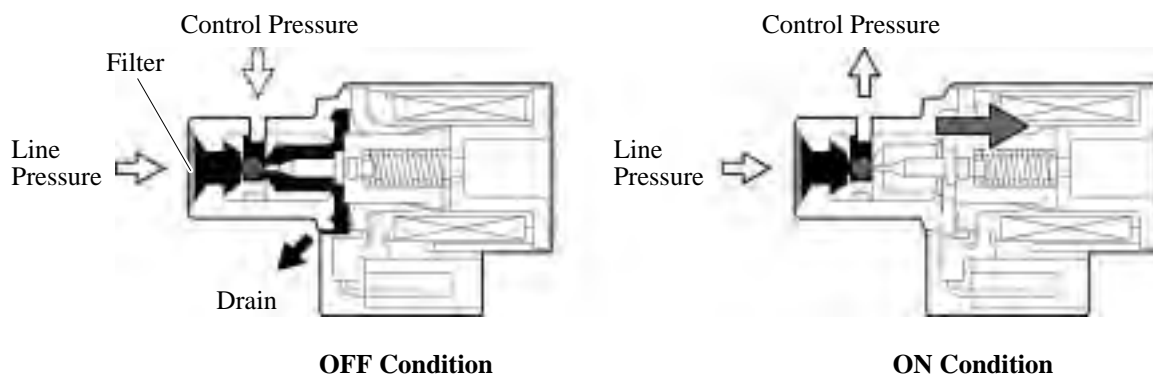

040SC11C

**2) Function of Solenoid Valve S1, S2, S3, S4 and SR**

Solenoid Valve	Type	Function
S1	3-way	<ul style="list-style-type: none"> <li>• Switches the 1-2 shift valve.</li> <li>• Switches the SL1 relay valve.</li> </ul>
S2	3-way	<ul style="list-style-type: none"> <li>• Switches the 2 - 3 shift valve.</li> <li>• Switches the 5 - 6 shift valve.</li> </ul>
S3	3-way	Switches the 3 - 4 shift valve.
S4	3-way	<ul style="list-style-type: none"> <li>• Switches the 4 - 5 shift valve.</li> <li>• Switches the SL1 relay valve.</li> <li>• Switches the reverse sequence valve.</li> </ul>
SR	3-way	<ul style="list-style-type: none"> <li>• Switches the clutch apply relay valve.</li> <li>• Switches the B<sub>1</sub> relay valve.</li> </ul>

**Solenoid Valve SL1, SL2, SLT and SLU**

**1) General**

In order to provide a hydraulic pressure that is in proportion to current that flows to the solenoid coil, the solenoid valve SL1, SL2, SLT, and SLU linearly controls the line pressure and clutch and brake engagement pressure based on the signals received from the Engine CPU.

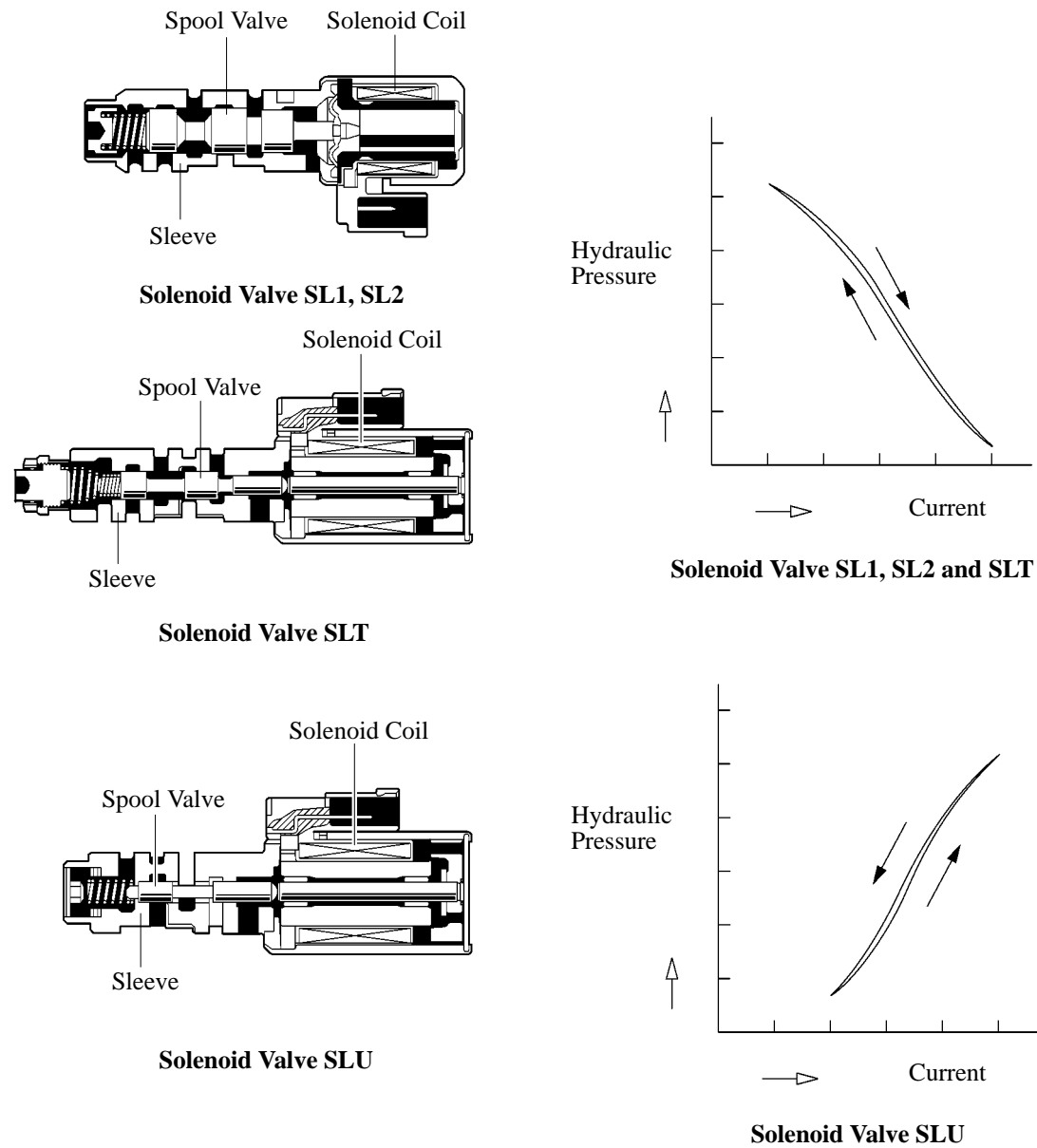

259LSK16

**2) Function of Solenoid Valve SL1, SL2, SLT and SLU**

Solenoid Valve	Function
SL1	<ul style="list-style-type: none"> <li>• Clutch pressure control</li> <li>• Accumulator back pressure control</li> </ul>
SL2	Brake pressure control
SLT	<ul style="list-style-type: none"> <li>• Line pressure control</li> <li>• Accumulator back pressure control</li> </ul>
SLU	<ul style="list-style-type: none"> <li>• Lock-up clutch pressure control</li> </ul>