



INTRODUCTION

1st Printing
September, 2010

TOUAREG, AUDI Q7, PORSCHE CAYENNE TR60SN "09D" Transmission

The Japanese company AISIN Co., LTD is the manufacturer and developer of the Rear Wheel Drive TR60SN transmission, which is a 6 speed, fully automatic and electronic controlled transmission. Volkswagen engineers were also involved, in conjunction with Aisin, in the development process for their vehicles and Volkswagen gave it the "09D" designation.

The TR60SN, 09D transmission is used in a wide variety of applications and engine sizes. As a result, the number of friction plates, and planetary gears (3 or 4 pinion), will vary depending on torque load requirements of the specific vehicle. The TR60SN transmission uses a gear ratio sensitive system, requiring the correct transmission interchange. The TR60-SN is currently used in the Porsche Cayenne, Volkswagen Touareg, and Audi Q7 vehicles.

The 09D transmission uses a Lepelletier arrangement, using a simple planetary coupled with a Ravigneaux type, dual planetary. This is the same type of gear set that was used in the FMX. This arrangement makes six forward speeds and reverse possible, with only five clutch packs and one freewheel.

This manual contains the procedures necessary to diagnose, rebuild and/or repair the TR60SN "09D" transmission and is intended for automotive technicians that are familiar with the operation of automatic transmissions.

We wish to thank Volkswagen® for the information that has made this booklet possible.

No part of any ATSG publication may be reproduced, stored in any retrieval system or transmitted in any form or by any means, including but not limited to electronic, mechanical, photocopying, recording or otherwise, without *written* permission of Automatic Transmission Service Group. This includes all text illustrations, tables and charts.

The information and part numbers contained in this booklet have been carefully compiled from industry sources known for their reliability, but ATSG does not guarantee its accuracy.

Copyright © ATSG 2010

WAYNE COLONNA
PRESIDENT

PETER LUBAN
TECHNICAL CONSULTANT

GERALD CAMPBELL
TECHNICAL CONSULTANT

JON GLATSTEIN
TECHNICAL CONSULTANT

GABE DE LOS REYES
TECHNICAL CONSULTANT

DALE ENGLAND
FIELD SERVICE CONSULTANT

JIM DIAL
TECHNICAL CONSULTANT

ED KRUSE
TECHNICAL CONSULTANT

GREGORY LIPNICK
TECHNICAL CONSULTANT

DAVID CHALKER
TECHNICAL CONSULTANT

ROLAND ALVAREZ
TECHNICAL CONSULTANT

GREG CATANZARO
TECHNICAL CONSULTANT

AUTOMATIC TRANSMISSION SERVICE GROUP
18635 S.W. 107 AVENUE
CUTLER BAY, FLORIDA 33157
(305) 670-4161



**TOUAREG, AUDI Q7,
PORSCHE CAYENNE
TR60SN "09D"**

INDEX

GENERAL DESCRIPTION AND VEHICLE APPLICATION CHART	3
COMPONENT APPLICATION CHART	4
IDENTIFICATION TAG LOCATION AND INFORMATION	5
CHECK FLUID LEVEL AND FLUID SPECIFICATIONS	6
SPEED SENSOR INFORMATION	7
PRESSURE SWITCH AND FLUID TEMPERATURE SENSOR INFORMATION	9
SOLENOID LOCATIONS AND IDENTIFICATION	10
INDIVIDUAL SOLENOID FUNCTION AND FAILURE RESULT	11
SOLENOID APPLICATION CHART	12
SOLENOID OPERATION	13
PASS-THRU CASE CONNECTORS AND WIRE HARNESS'	15
CASE CONNECTOR TERMINAL IDENTIFICATION	16
CASE CONNECTOR INTERNAL COMPONENT RESISTANCE CHARTS	17
TCM CONNECTOR INTERNAL COMPONENT RESISTANCE CHARTS	18
TRANSAXLE RANGE SWITCH OPERATION AND DIAGNOSIS	19
STANDARD AND TIPTRONIC SHIFT QUADRANTS	21
EMERGENCY "LIMP" MODE AND TOWING INFORMATION	22
TYPICAL WIRE SCHEMATIC	23
DIAGNOSTIC TROUBLE CODE DESCRIPTION	24
PRESSURE SPECIFICATIONS	26
PRESSURE TAP LOCATIONS AND IDENTIFICATION	27
OIL PASSAGE IDENTIFICATION	28
TRANSMISSION DISASSEMBLY	31
COMPONENT REBUILD	
TRANSMISSION CASE ASSEMBLY	52
K2 CLUTCH HOUSING ASSEMBLY	57
OUTPUT SHAFT, REAR RING GEAR ASSEMBLY	62
REAR PLANETARY ASSEMBLY	65
F1 SPRAG ASSEMBLY	66
SUN GEARS AND THRUST BEARINGS	68
K1 CLUTCH HOUSING ASSEMBLY	71
K3 CLUTCH HOUSING ASSEMBLY	75
TORQUE CONVERTER OPERATION, "2-Port" And "3-Port" Differences	79
OIL PUMP DIFFERENCES	80
TURBINE SHAFT DIFFERENCES	81
FRONT PLANETARY ASSEMBLY	82
OIL PUMP ASSEMBLY	86
VALVE BODY ASSEMBLY	91
"UPDATED" 2005-UP VALVE BODY INFORMATION	103
TRANSMISSION FINAL ASSEMBLY	114
B2 CLUTCH CLEARANCE MEASUREMENT	116
F1 ROLLER CLUTCH FREEWHEEL DIRECTION	118
B1 CLUTCH CLEARANCE MEASUREMENT	123
TRANSMISSION END-PLAY MEASUREMENT	124
TORQUE SPECIFICATIONS	133
THRUST WASHER AND BEARING IDENTIFICATION	134

AUTOMATIC TRANSMISSION SERVICE GROUP

**18635 S.W. 107 AVENUE
CUTLER BAY, FLORIDA 33157
(305) 670-4161**

Copyright © ATSG 2010

GENERAL DESCRIPTION

The Japanese company AISIN Co., LTD is the manufacturer and developer of the Rear Wheel Drive TR-60SN transmission, which is a 6 speed, fully automatic and electronic controlled gearbox. Volkswagen engineers were also involved, in conjunction with Aisin, in the development process for their vehicles and they gave it the 09D designation. Vehicle applications and transmission codes known at time of printing, are shown in Figure 1.

The 09D transmission is used in a wide variety of applications and engine sizes. As a result, the number of friction plates and three or four pinion carriers, will vary depending on torque load requirements of the specific vehicle. The 09D transmission uses a gear ratio sensitive system, *requiring* the correct transmission interchange, if that becomes necessary.

The Transmission Control Module (TCM) is mounted external from the transmission which makes typical electrical diagnosis available to the technician.

The TCM controls both shift timing and shift feel with the use of eight solenoids. The TCM monitors gear ratio through the input and output shaft hall effect speed sensors. It also can determine the rate of change and adapt the shifts as the friction elements wear.

TR-60SN (09D) transmissions use a Lepelletier type gear set arrangement, which consists of a simple planetary with the sun gear splined to the pump stator and coupled with a Ravigneaux type, dual planetary. This is similar to but not the same, as the type of planetary that was used in the FMX. This arrangement allows the sun gears and the planetary pinions of the Ravigneaux planetary gear-set to be driven at different speeds and makes six forward speeds and reverse possible, with only five clutch packs and one freewheel.

Lepelletier's brilliant idea has led to several different manufacturers using this gear set arrangement in their own versions of six forward speeds transmissions.

Refer to Figure 2 for the component locations and the clutch application chart for each gear.

VEHICLE APPLICATION CHART					
VEHICLE	YEAR	ENGINE	CODES	VW	AISIN
AUDI, Q7	2007-Up	4.2L (V8) 257 kW	HPH,	09D	TR60SN
PORSCHE, CAYENNE	2003-Up	3.2L (V6) 162 kW		09D	TR60SN
TOUAREG	2003-Up	3.2L (V6) 162 kW	BAA, BMX, EXL, EXQ, HAM,	09D	TR60SN
TOUAREG	2003-Up	3.2L (V6) 177 kW	BAA, BMX, EXP, GLK, HAM, HAP,	09D	TR60SN
TOUAREG	2003-Up	3.6L (V6) 206 kW	BHK, HPG, HZW, JXU,	09D	TR60SN
TOUAREG	2003-Up	4.2L (V8) 228 kW	FCS, GLH, HAU, HZV,	09D	TR60SN
TOUAREG	2003-Up	4.2L (V8) 257 kW	AXQ, BAR, BHX, HPH, JXS, KMF,	09D	TR60SN
TOUAREG	2003-Up	3.0L (V6 Diesel) 165 kW	KRK,	09D	TR60SN
TOUAREG	2003-Up	4.9L (V10 Diesel) 230 kW	GLD, GTK, HAQ, HZX	09D	TR60SN
TOUAREG	2003-Up	4.9L (V10 Diesel) 258 kW	JXV,	09D	TR60SN

Copyright © 2010 ATSG

Figure 1

COMPONENT APPLICATION CHART

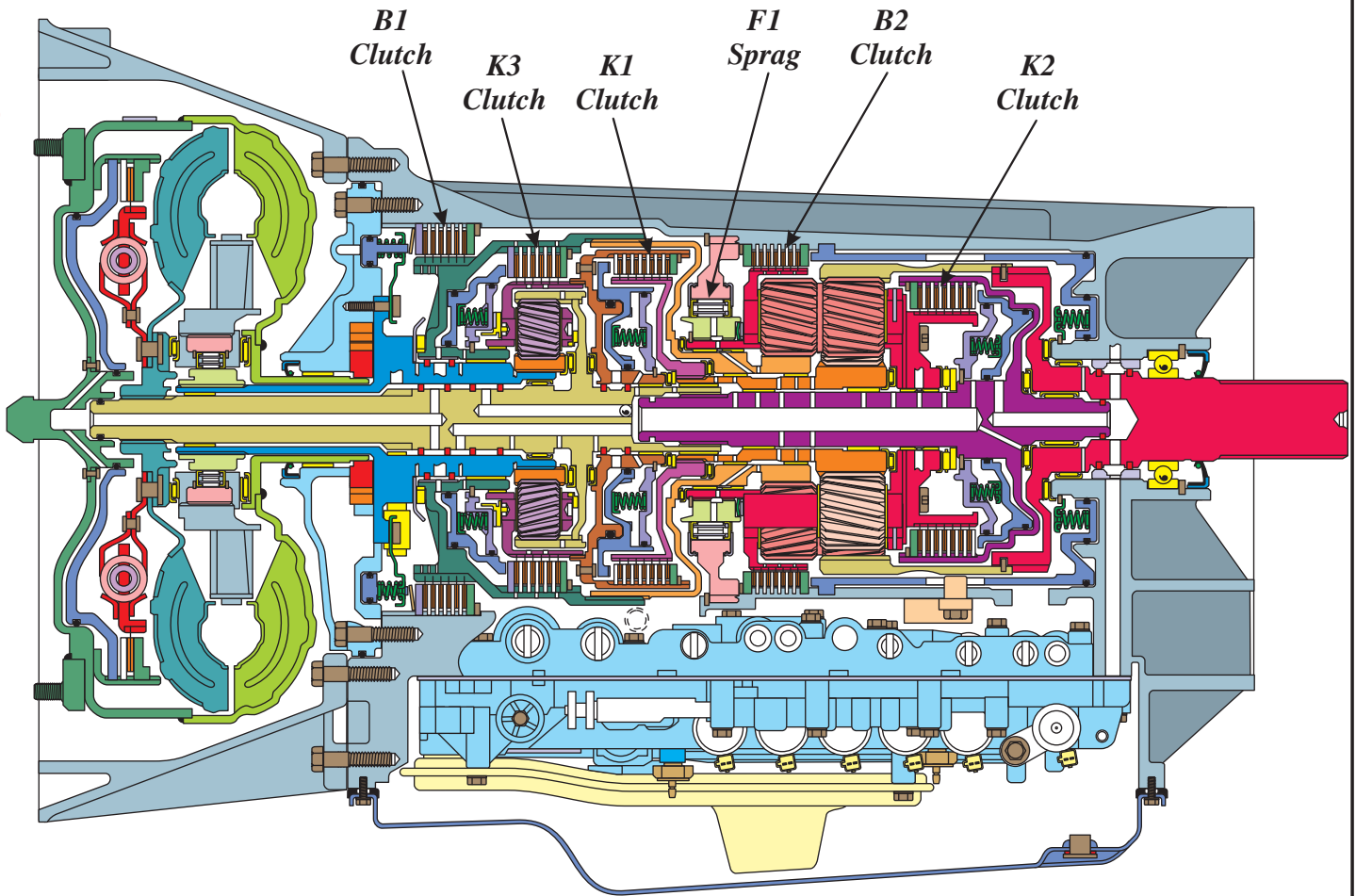

COMPONENT APPLICATION CHART

<i>Gear</i>	<i>K-1 Clutch</i>	<i>K-2 Clutch</i>	<i>K-3 Clutch</i>	<i>B-1 Clutch</i>	<i>B-2 Clutch</i>	<i>F-1 Sprag</i>	<i>Torque Conv. Clutch</i>	<i>Gear Ratio (Model Dependant)</i>
<i>1st Gear</i>	<i>On</i>				<i>On*</i>	<i>Hold</i>		<i>4.148</i>
<i>2nd Gear</i>	<i>On</i>			<i>On</i>				<i>2.370</i>
<i>3rd Gear</i>	<i>On</i>		<i>On</i>				<i>On**</i>	<i>1.556</i>
<i>4th Gear</i>	<i>On</i>	<i>On</i>					<i>On**</i>	<i>1.155</i>
<i>5th Gear</i>		<i>On</i>	<i>On</i>				<i>On**</i>	<i>0.859</i>
<i>6th Gear</i>		<i>On</i>		<i>On</i>			<i>On**</i>	<i>0.686</i>
<i>Rev Gear</i>			<i>On</i>		<i>On</i>			<i>3.394</i>

* The B-2 Clutch is applied in "Tiptronic Mode" 1st gear, only for engine braking.

** During normal driving operation, the Torque Converter Clutch may be applied in 3rd thru 6th gear.

Figure 2

TRANSMISSION IDENTIFICATION

The transmission identification tag is located on the left hand side of the transmission case, as shown in Figure 3. All of the information from the ID tag will be needed to order anything from the dealer for this transmission. Currently there are no hard parts available from the dealer so you will have to rely on aftermarket sources if hard part replacement becomes necessary.

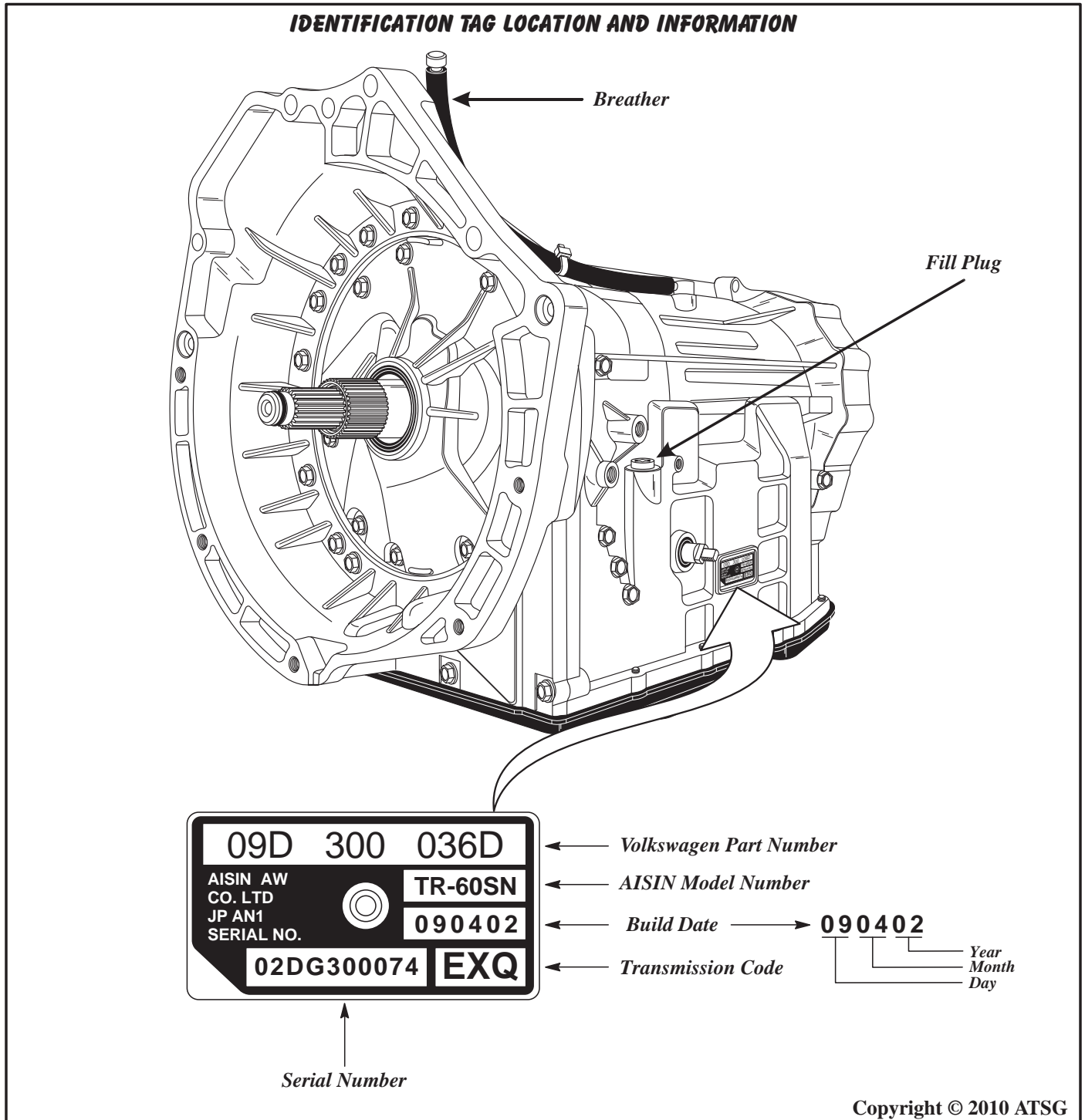

Figure 3

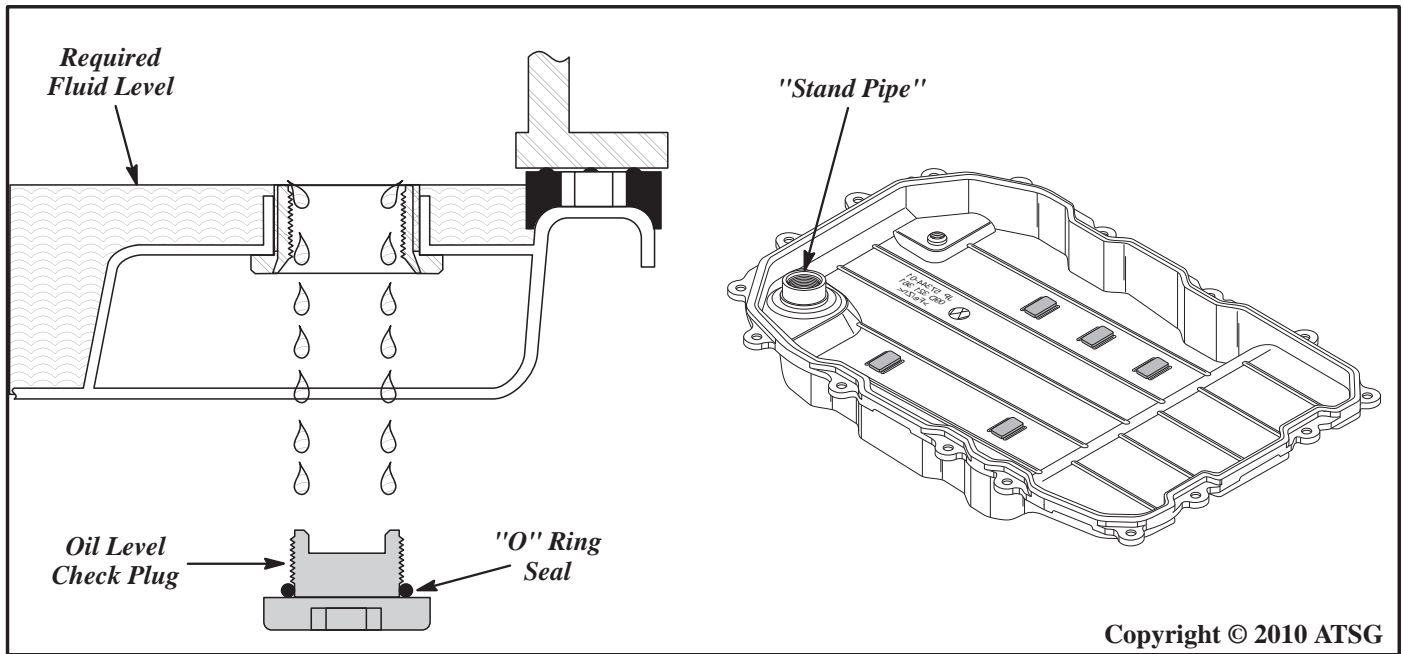

Figure 4

CHECK FLUID LEVEL AND SPECIFICATION

To "Check" for the correct fluid level, you must remove the "check" plug, which is located in the corner of the pan, and is removed with a 16 mm allen wrench, as shown in Figure 4 and 5.

We have provided you with a cut-away drawing of the bottom oil pan and the check plug so that you will understand how this system works. Notice that the oil pan actually has a "stand-pipe", as shown in Figure 4, that is stamped into and extends up above the pan rail, and is our way to establish the proper fluid level in the transmission.

- (A) Engine must be running and the manual shift lever placed in the Park position.
- (B) Transmission must be at operating temperature and parked on level surface.
- (C) By removing the "Check" plug from the oil pan, the fluid should just trickle over the "stand-pipe" and out through the center of the stand-pipe in the oil pan, as shown in Figure 4.
- (D) Always replace the "O" ring on the check plug and torque check plug to 28 N·m (20 ft.lb.)

The "Drain" plug can be removed, using a 40 Torx bit, to facilitate in draining the fluid for transmission removal, or filter change. The pan gasket can be re-used as long as there is no damage.

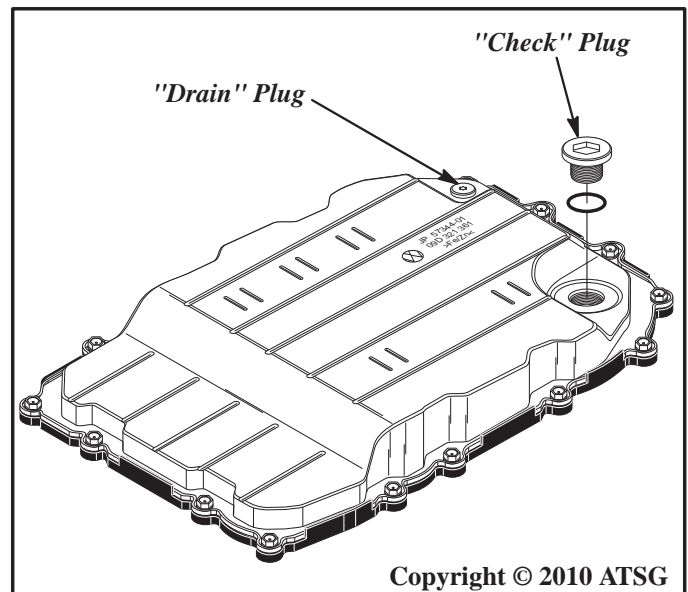

Figure 5

To "Fill" or "Add" fluid to the transmission, there is a fill plug located on the left side of the case just above and left of the manual lever seal, as shown in Figure 3.

Only the approved type of ATF fluid should be used, as shown below. Damage may result if the proper fluid is not used.

Fluid Requirements
VW Part No. G 052 025 A2
(Esso JWS 3309) Lifetime Fluid

ELECTRONIC COMPONENTS

Input Speed Sensor (G182)

The Input Speed Sensor (G182) is located in the transmission oil pump stator, as shown in Figure 7, and retained with a bolt. The ISS has a Yellow connector that mounts on the back side of the oil pump body and is also retained with a bolt, as shown in Figure 7. The ISS signal is routed through the 8-way case connector.

The ISS is triggered by rotor teeth on the turbine shaft to determine exact transaxle turbine speed, as shown in Figure 7. The TCM uses this information to control line pressure for garage shifts, control and monitor torque converter lock-up clutch, monitor gear ratios and diagnosis of shift components via the Dynamic Shift Program (DSP), which is VW's name for the shift adapt feature in the TCM.

The ISS is based on the Hall Effect principle. The signal is a square-wave signal whose frequency is proportional to turbine shaft speed. Should the Input Speed Sensor fail, the engine RPM sensor is used as a back-up, but when engine RPM sensor is used there will be no shift adapt operations, no controlled pulse width modulation for TCC lock-up (apply and release only) and no pressure control on garage shifts (N-D, N-R) which will create harsh garage shift engagements.

The Input Speed Sensor is shown in Figure 6.

Special Note:

The ISS and OSS are Hall Effect Sensors and should be checked using a scope under operating conditions. The resistance values provided in the Figures below are from new sensors. Resistance checks on these type of sensors would, at best, inform you of either open or grounded circuits within the sensor itself.

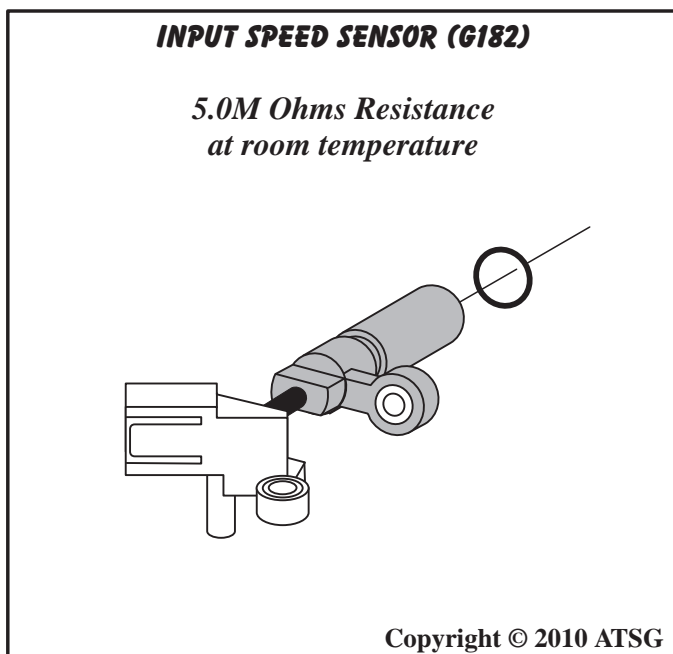

Figure 6

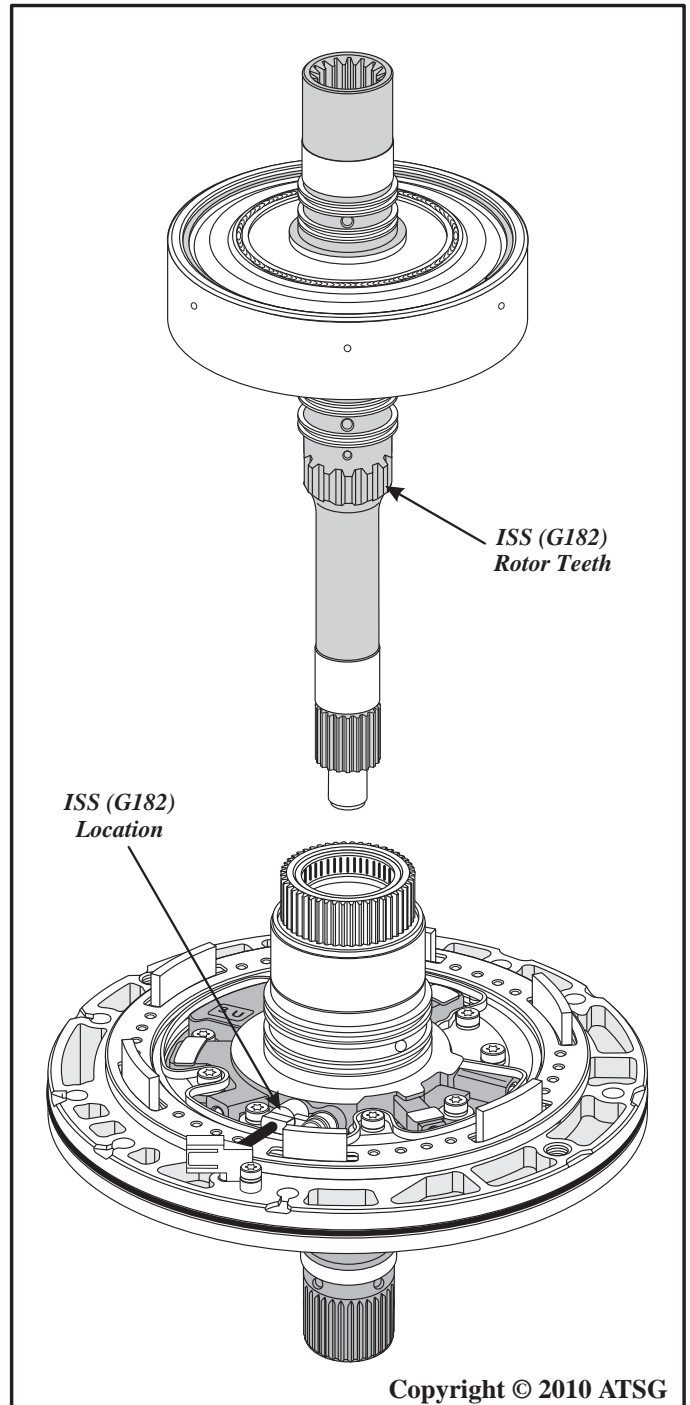

Figure 7

Output Speed Sensor (G195)

The Output Speed Sensor (G195) is located in the transmission case below the valve body, as shown in Figure 9, and retained with a bolt. The OSS has a White connector that mounts on one of the solenoid pin retaining brackets on the valve body. The OSS signal is fed through the 8-way case connector.

The OSS is triggered by the external lugs on the rear planetary ring gear, to determine exact transmission output shaft speed. The TCM uses this information to determine shift points, control and monitor torque converter lock-up clutch, monitor gear ratios and diagnosis of shift components via the Dynamic Shift Program (DSP), which is VW's name for the shift adapt feature in the TCM.

The OSS is based on the Hall Effect principle. The signal is a square-wave signal whose frequency is proportional to output shaft speed. Should the Output Speed Sensor fail, the speed signal from the ABS Control Module is used as back-up, with limited shift adapt capability.

The Output Speed Sensor is shown in Figure 8.

Special Note:

The ISS and OSS are Hall Effect Sensors and should be checked using a scope under operating conditions. The resistance values provided in the Figures below are from new sensors. Resistance checks on these type of sensors would, at best, inform you of either open or grounded circuits within the sensor itself.

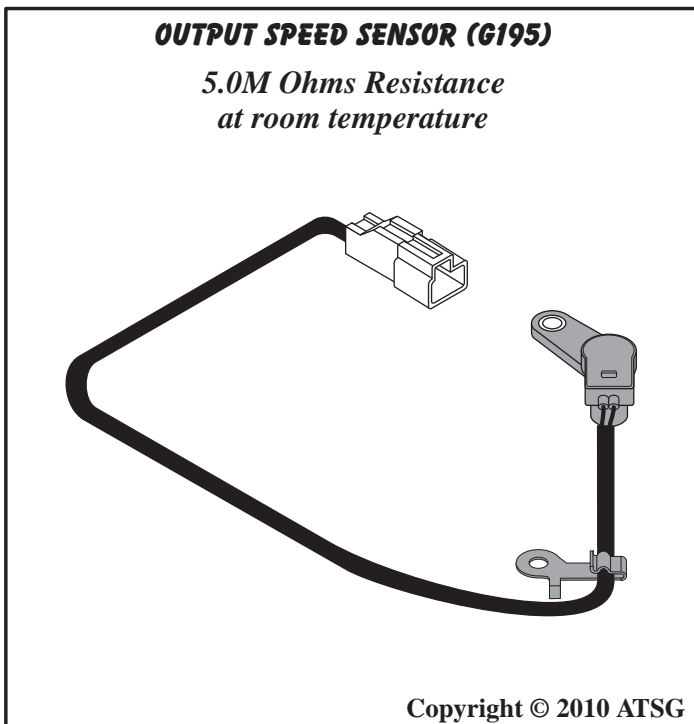

Figure 8

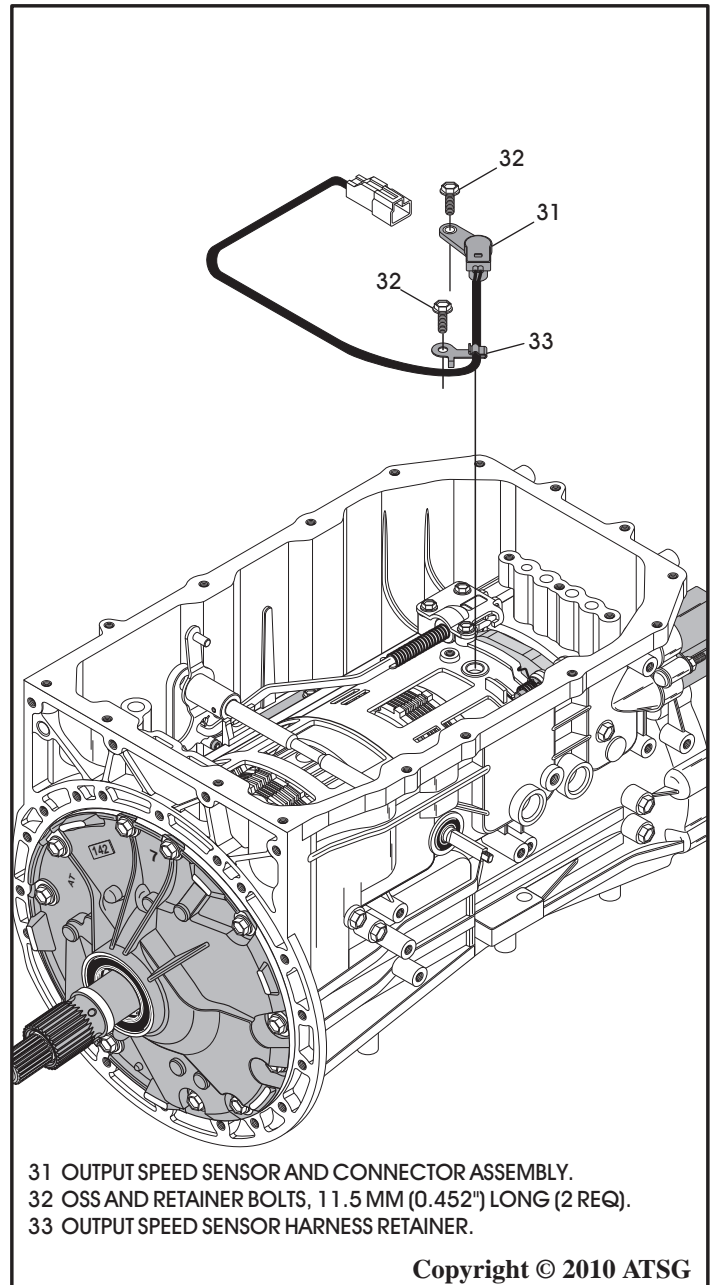

Figure 9

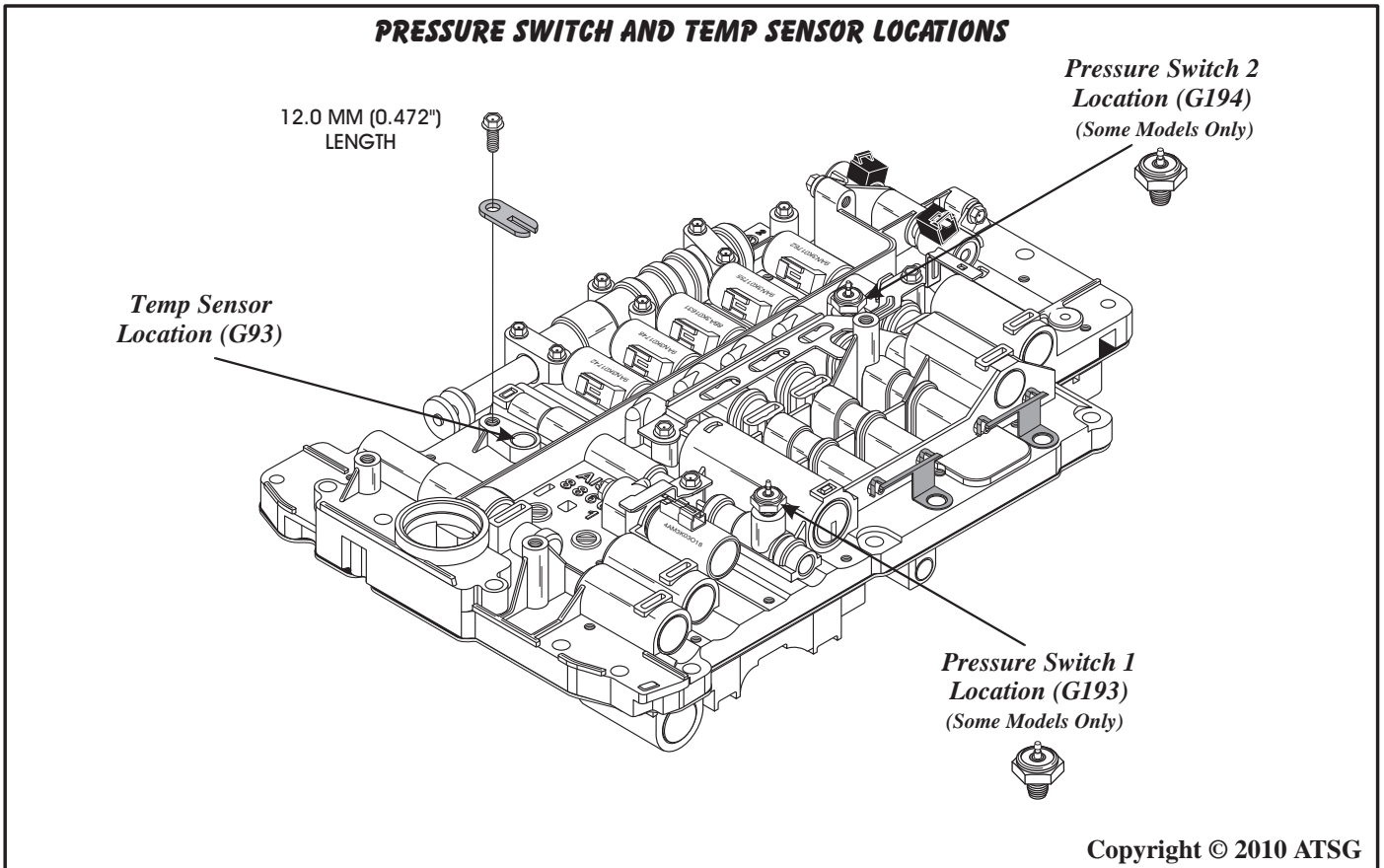

Figure 10

ELECTRONIC COMPONENTS (CONT'D)

Pressure Switches 1 (G193) And 2 (G194)

Some "09D" transmissions are equipped with two pressure switches that screw into the valve body casting in the locations shown in Figure 10. Both switches are "normally open" switches that connect to ground when pressure exceeds approx. 44 psi and are used to verify valve movement in the valve body assembly.

Pressure Switch 1 (G193) is used to verify activation of the K-1 clutch.

Pressure Switch 2 (G194) is used to verify activation of the B-2 clutch. Therefore, pressure switch 2 is closed in tiptronic mode only, 1st gear. The only other time the B-2 clutch is required is in reverse (R) gear. Pressure Switch 2 does not close in the reverse position, as reverse is engaged by the manual valve hydraulically.

Note: Pressure switches are used only on some models equipped with the "09D" transmission.

Continued on Page 10

TRANSAXLE FLUID TEMP SENSOR (G93)

Temperature F° (C°)	Resistance
-22°F (-30°C)	37K - 51K Ohms
50°F (10°C)	5K - 8K Ohms
77°F (25°C)	3K - 5K Ohms
230°F (110°C)	230 - 265 Ohms
293°F (145°C)	100 - 120 Ohms

Copyright © 2010 ATSG

Figure 11

ELECTRONIC COMPONENTS (CONT'D)

Transaxle Fluid Temp Sensor (G93)

The Transaxle Fluid Temp Sensor (G93) is located in the valve body and is mounted with a retaining plate, as shown in Figure 10. Notice in Figure 11 that an "O" ring is required, as it is mounted into an oil passage. The TFT is an integral part of the 8-way case connector and wire harness assembly.

The TFT is a negative temperature coefficient sensor, which means that as temperature rises the resistance decreases, as shown in Figure 11.

Starting at 150°C (270°F), the converter clutch is applied more frequently. If this does not result in cooling of the ATF, reduction of engine torque is initiated at 170°C (306°F).

Should the TFT fail, a substitute value is generated from the engine temperature and operating duration. There will be no controlled operation (ramping) of the converter clutch (ON or Off only) and no controlled shift adapt pressures, which usually results in harsh engagements.

Solenoid Identification And Location

The 09D transmission uses a total of 8 different solenoids located in the valve body that are used to apply or release the clutches, control the main line pressure and apply or release the torque converter clutch. They are identified and their locations are shown in Figure 12.

There are three different types of solenoids used in the "09D" transmission. There are two "Normally Closed" On/Off solenoids, one "Normally Vented" Pulse Width Modulated (PWM) solenoid, and the other five are "Normally Applied" Pulse Width Modulated (PWM) solenoids.

Refer to Figure 13 for their individual functions and Figure 12 for their locations in the valve body.

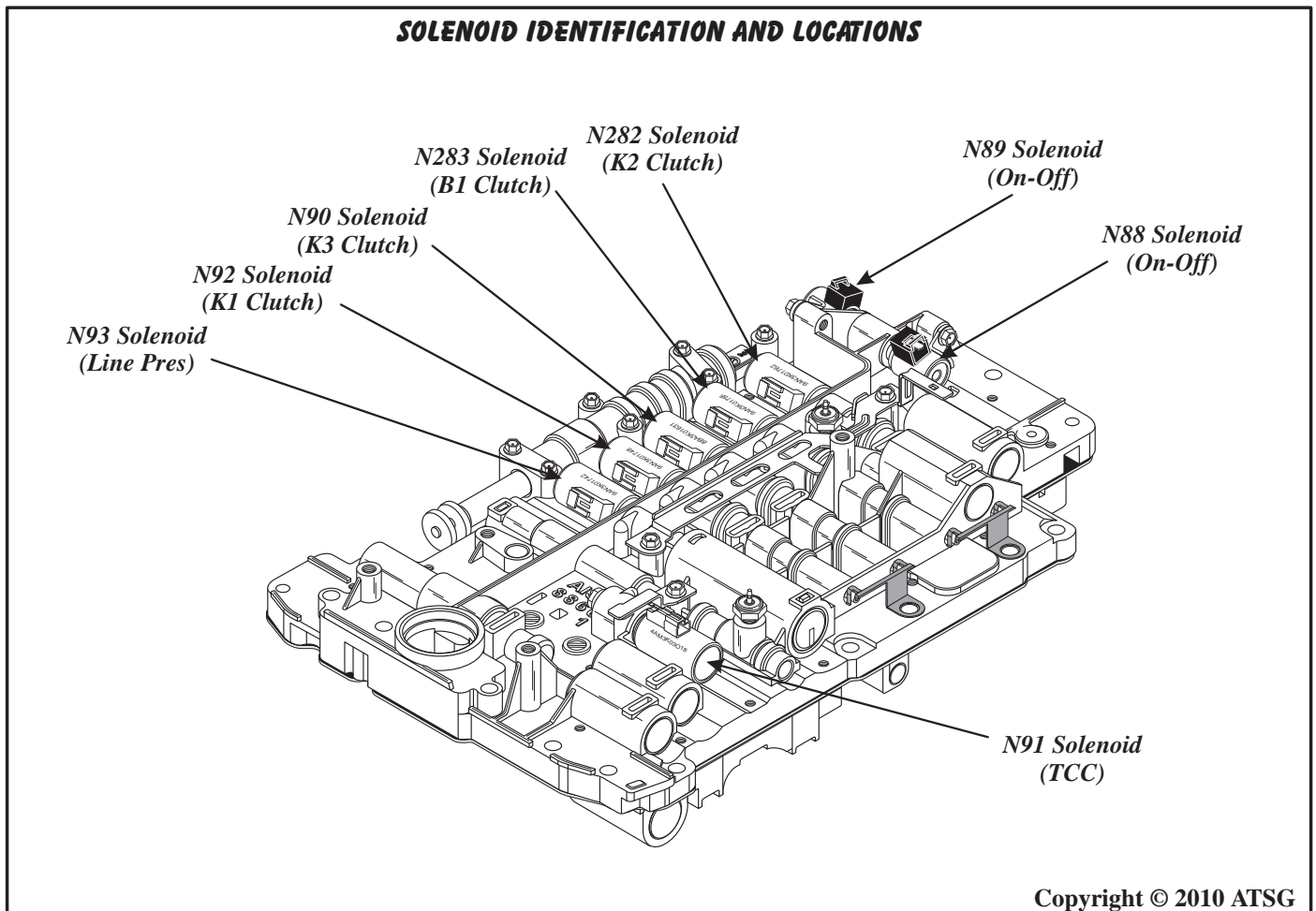

Figure 12

INDIVIDUAL SOLENOID FUNCTION AND RESULT OF FAILURE***N88 Solenoid (No. 1 Solenoid)***

The N88 Solenoid is an ***On/Off*** solenoid and is On and Open in gears 4th through 6th. If this solenoid fails in the Closed (Off) position, 4th through 6th gear will not be available.

N89 Solenoid (No. 2 Solenoid)

The N89 Solenoid is also an ***On/Off*** solenoid and is On and Open, to allow a line pressure increase when the torque converter clutch is applied. When both the N88 and N89 solenoids are energized at the same time, the B2 brake clutch is applied in Tiptronic 1st Gear (Manual Low). If the N89 Solenoid fails in the Closed (Off) position, there will be no pressure increase in TCC and no engine braking in Tiptronic 1st gear (Manual Low).

N90 Solenoid (No. 3 Solenoid)

The N90 Solenoid is a ***normally applied***, pulse width modulated solenoid controlling the apply and release of the K3 Clutch. When this solenoid is fully Off, the K3 clutch is fully applied. If this solenoid fails in the Off (Normally Applied) position, there will be 3rd gear starts and Reverse application may be firm.

N91 Solenoid (No. 4 Solenoid)

The N91 Solenoid is a ***normally vented***, pulse width modulated solenoid controlling the apply and release of the converter clutch, with the ability to ramp the apply and release. When this solenoid is fully Off, the converter clutch is fully released. If this solenoid fails in the Off (Normally Vented) position, there will be no converter clutch application.

Solenoid N92 (No. 5 Solenoid)

The N92 Solenoid is a ***normally applied***, pulse width modulated solenoid controlling the apply and release of the K1 Clutch. When this solenoid is fully Off, the K1 clutch is fully applied. If this solenoid fails in the Off (Normally Applied) position, Drive engagement will be firm, and there will be a bind in 5th.

Solenoid N93 (No. 6 Solenoid)

The N93 Solenoid is a ***normally applied***, pulse width modulated solenoid and controls the main line pressure. When this solenoid is fully Off, maximum line pressure is the result. If this solenoid fails in the Off (Normally Applied) position, all shifts will be harsh.

Solenoid N282 (No. 9 Solenoid)

The N282 Solenoid is a ***normally applied***, pulse width modulated solenoid controlling the apply and release of the K2 Clutch. When this solenoid is fully Off, the K2 clutch is fully applied. If this solenoid fails in the Off (Normally Applied) position, 4th shift may be firm.

Solenoid N283 (No. 10 Solenoid)

The N283 Solenoid is a ***normally applied***, pulse width modulated solenoid controlling the apply and release of the B1 Clutch. When this solenoid is fully Off, the B1 clutch is fully applied. If this solenoid fails in the Off (Normally Applied) position, there may be 2nd gear starts..

Note: Refer to Figure 14 for Solenoid Application chart and Clutch Application chart for each gear. You will also find an observed Amperage chart from the actual vehicle that you can use for comparison. This should make the diagnosis process much easier for the vehicle that you are repairing.

SHIFT SOLENOID AND CLUTCH APPLICATION CHART														
Gear Shift Position	Solenoid Shift Sequence								Clutch Application Chart					
	On/Off Solenoids		Pressure Control Solenoids						Clutch and Freewheel Components					
	N89 SV-2	N88 SV-1	N92 SV-5	N282 SV-9	N90 SV-3	N283 SV-10	N93 SV-6	N91 SV-4	K1	K2	K3	B1	B2	F1
Park			OFF	OFF	ON	ON	PWM							
Neutral			ON	ON	ON	ON	PWM							
Reverse			ON	ON	OFF	ON	PWM				ON		ON	
1st Gear	T	T	OFF	ON	ON	ON	PWM		ON					ON
2nd Gear			OFF	ON	ON	OFF	PWM	PWM	ON			ON		
3rd Gear	T/To	To	OFF	ON	OFF	ON	PWM	PWM	ON		ON			
4th Gear	T/To	To	OFF	OFF	ON	ON	PWM	PWM	ON	ON				
5th Gear	T/To	To	ON	OFF	OFF	ON	PWM	PWM		ON	ON			
6th Gear	ON	To	ON	OFF	ON	OFF	PWM	PWM		ON		ON		

T = On in Tiptronic Mode
To = Solenoid is toggled On to Off

SOLENOID OBSERVED AMPERAGE CHART										
SOLENOID	RANGE				GEAR					
	Park	Reverse	Neut	Drive 1	Manual 1	2	3H 3M	4H 4M	5H 5M	6H 6M
SV5-N92 (K1)	.100A	.980A	.980A	.100A	.100A	.100A	.100A	.100A	.980A	.980A
SV9-N282 (K2)	.100A	.980A	.980A	.980A	.980A	.980A	.980A	.100A	.100A	.100A
SV3-N90 (K3)	.980A	.100A	.980A	.980A	.980A	.980A	.100A	.980A	.100A	.980A
SV10-N283 (B1)	.980A	.980A	.980A	.980A	.980A	.100A	.980A	.980A	.980A	.100A
SV6-N93 (LP)	.980A	.980A	.980A	.980A	.740A	.860A	.980A	.980A	.740A	.740A
SV4-N91 (TCC)	.200A	.200A	.200A	.200A	.200A	.200A	.200A .990A	.200A .990A	.200A .990A	.200A .990A
SV2-N89	0	0	0	0	1	0	0-1*	0-1*	0-1*	1
SV1-N88	0	0	0	0	1	0	1*-0	1*-0	1*-0	1*-0

.100A= Very Low amperage Solenoid OFF
.980A= Very High amperage Solenoid ON

SV1-N88
0 =OFF
1=ON
1*-0= ON to OFF during shift transitions

SV2-N89
0 =OFF
1=ON
0-1*= OFF to ON when TCC is ON

3H = 3rd Gear TCC OFF
3M = 3rd Gear TCC ON
(This applies to gears 3-6)

Solenoids SV3, 5, 9 and 10 are Normally Applied, which applies their assigned component when they are Off. They are Energized (On) to release their assigned component. These solenoids are also Modulated, to control their assigned component apply and release rates. Consult the charts above to compare the amperage to clutch application.

Solenoid SV6 (N93) is modulated based on engine load to control main line pressure. Amperage will decrease to increase main line pressure.

Note: N88 is pulsed ON to OFF during the transitions from 3rd thru 6th gears, although it is not necessary once the K2 Clutch is on, as there is pressure fed to the NO.2 Relay valve stroking the valve.

Figure 14

ELECTRONIC COMPONENTS (CONT'D)

SOLENOID OPERATION

On/Off Solenoids (N88), (N89)

These solenoids are the same and both operate in exactly the same manner, as shown in Figure 15, based on commands from the TCM. Both of the On/Off solenoids are "Normally Closed".

These two solenoids operate in conjunction with the Pulse Width Modulated (PWM) solenoids to provide the proper gear ratio for the current road conditions.

Refer to Figure 15 for operational checks. Check these solenoids for proper resistance with the positive lead of Ohm Meter to the terminal and the negative lead to the case of the solenoid. When comparing On/Off solenoids, resistance should be within .5 Ohms of one another.

PWM Solenoid (N91)

PWM Solenoid (N91) operates exactly the opposite of the other PWM solenoids, in that it is "Normally Vented", as shown in Figure 16.

Notice that the solenoid feed oil is fed through a .032" orifice, down the side of the solenoid and back through a passage to either TCC feed or to exhaust, depending on whether the solenoid is On or Off, as shown in Figure 16. Check these solenoids for proper resistance with the leads of the Ohm Meter across the terminals. When comparing PWM solenoids, resistance should be within .5 Ohms of one another.

PWM Solenoids (N90), (N92), (N93), (N282), (N283)

PWM Solenoids (N90), (N92), (N93), (N282), and (N283) operate exactly the opposite of the (N91) PWM solenoid, as they are "Normally Applied", as shown in Figure 17. Even though these solenoids look the same, there are different part numbers on each of them which would suggest that they may be different internally.

Notice that the solenoid feed oil is fed through a .032" orifice, down the side of the solenoid and back through a passage to solenoids assigned component or to exhaust, depending on whether the solenoid is On or Off, as shown in Figure 17. Check these solenoids for proper resistance with the leads of the Ohm Meter across the terminals.

Refer to Figure 13 for the component assigned to each of these PWM solenoids. When comparing PWM solenoids, resistance should be within .5 Ohms of one another.

Electronic Components
Continued on Page 15

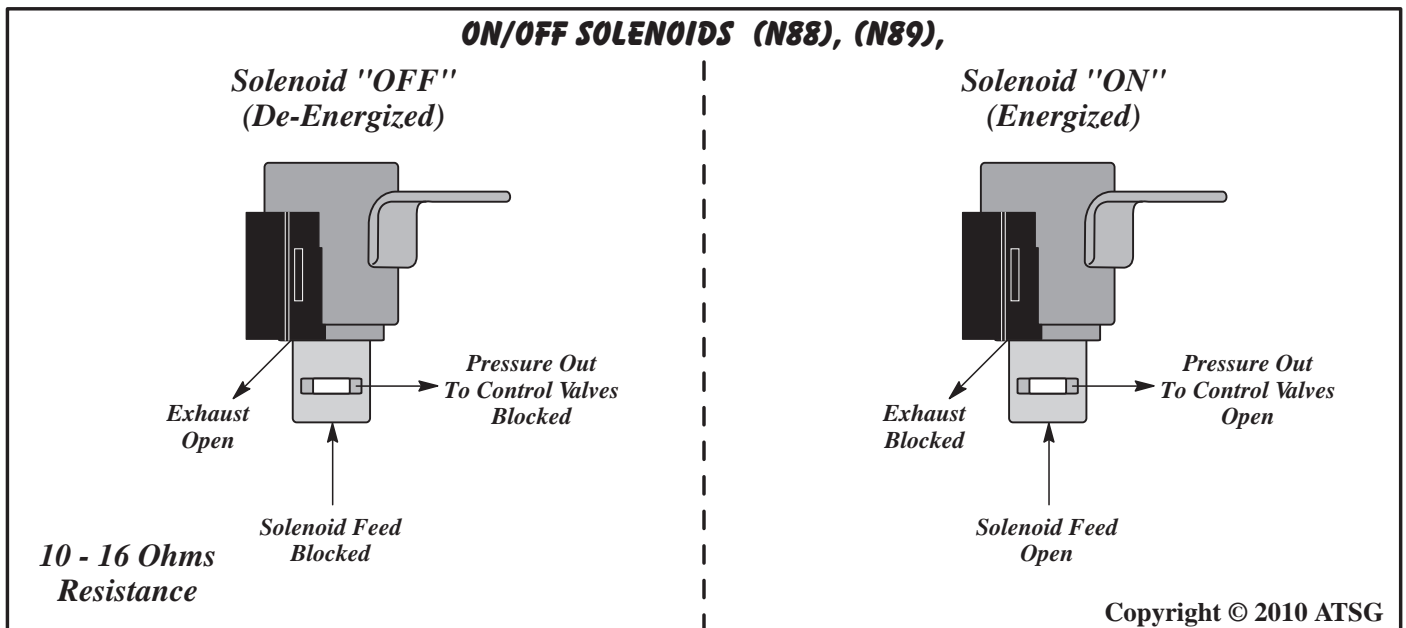

Figure 15

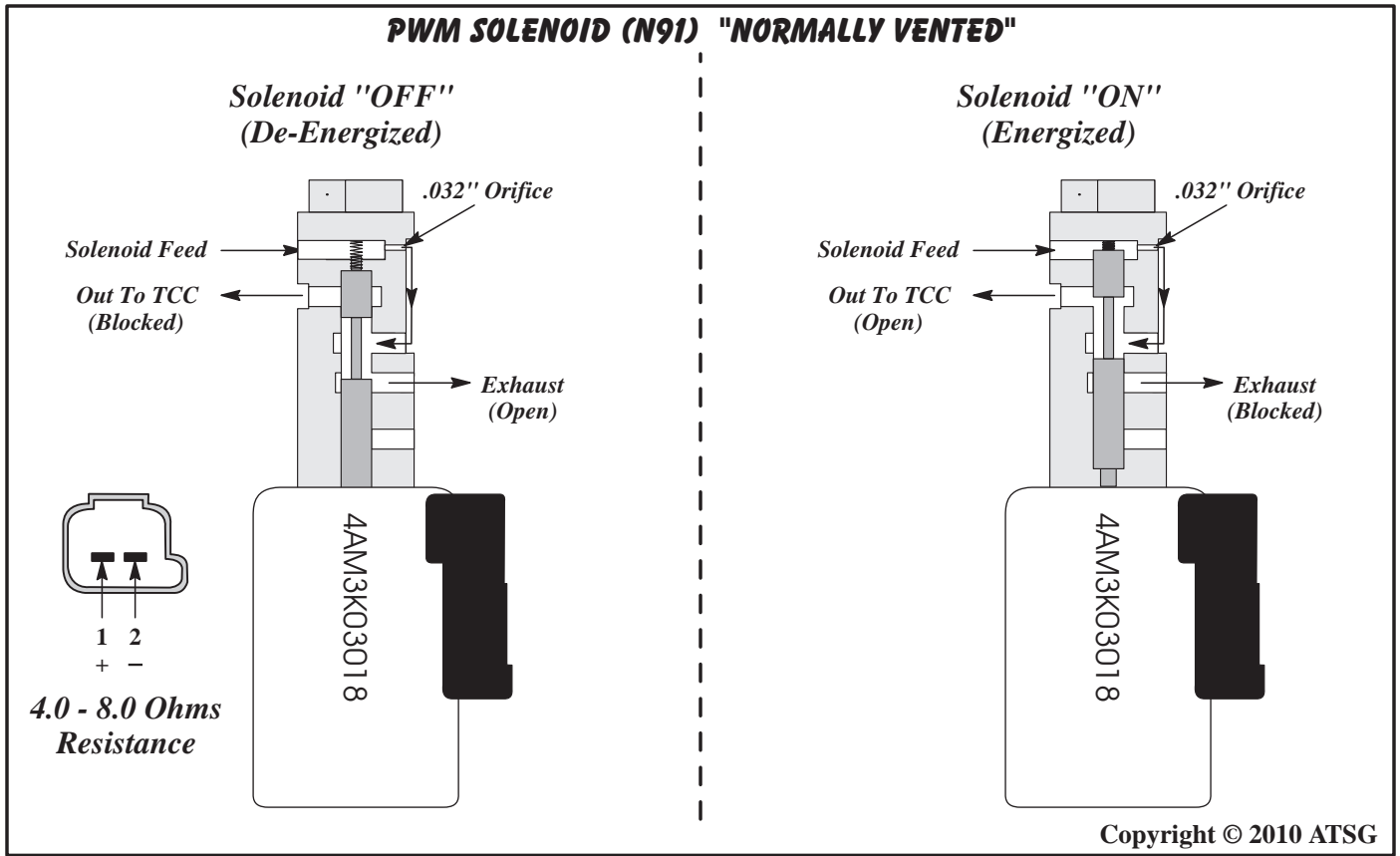

Figure 16

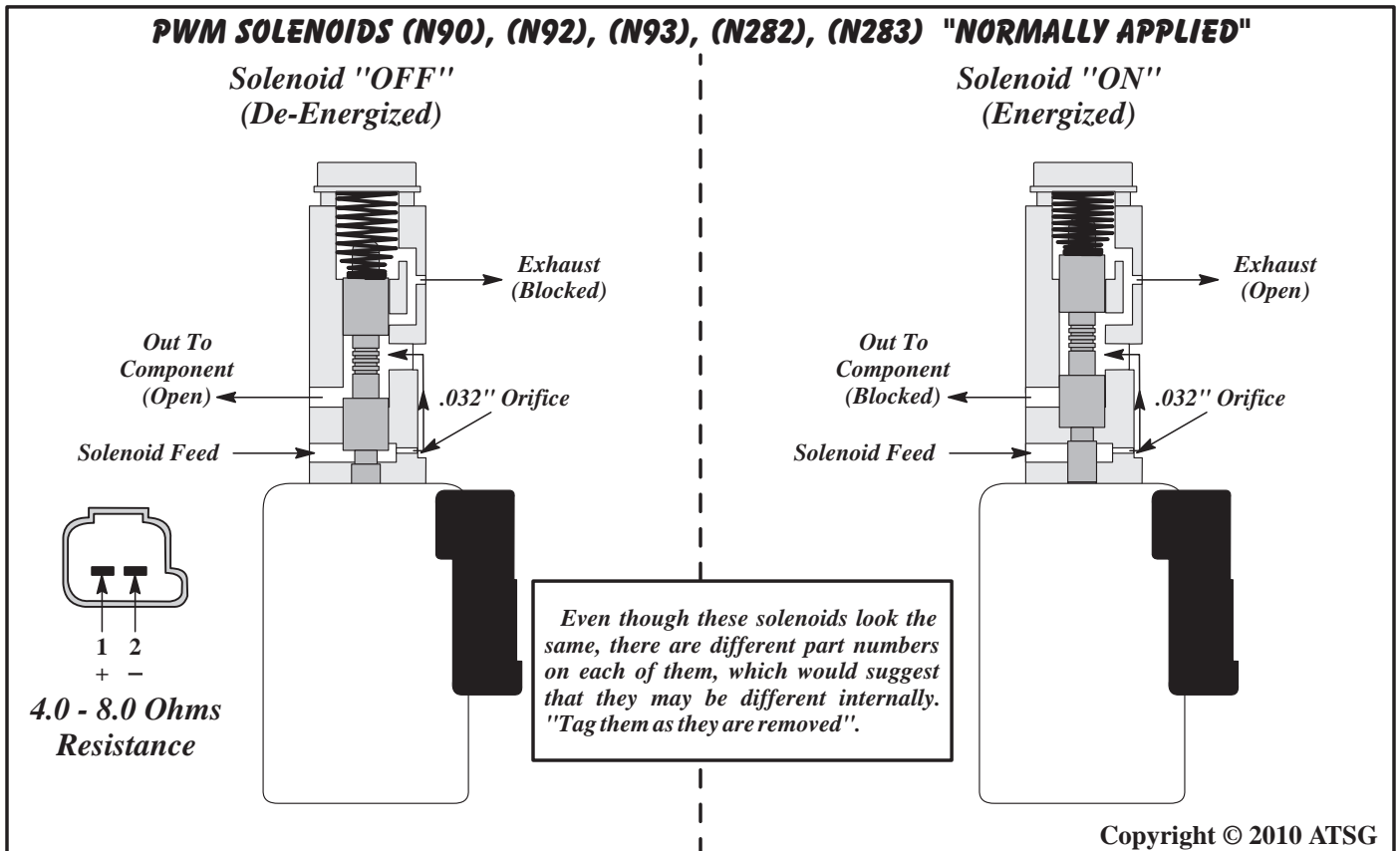

Figure 17

ELECTRONIC COMPONENTS (CONT'D)

Pass-Thru Case Connectors

There are 2 pass-thru case connectors and internal wire harness assemblies used on the "09D" transmissions. One is an 8-way connector that serves all of the internal sensors and switches, and one 14-way connector that serves all of the solenoids, as shown in Figure 18.

As stated previously, the transmission temp sensor is an integral part of the 8-way connector and wire harness assembly, as shown in Figure 18.

Continued on Page 16

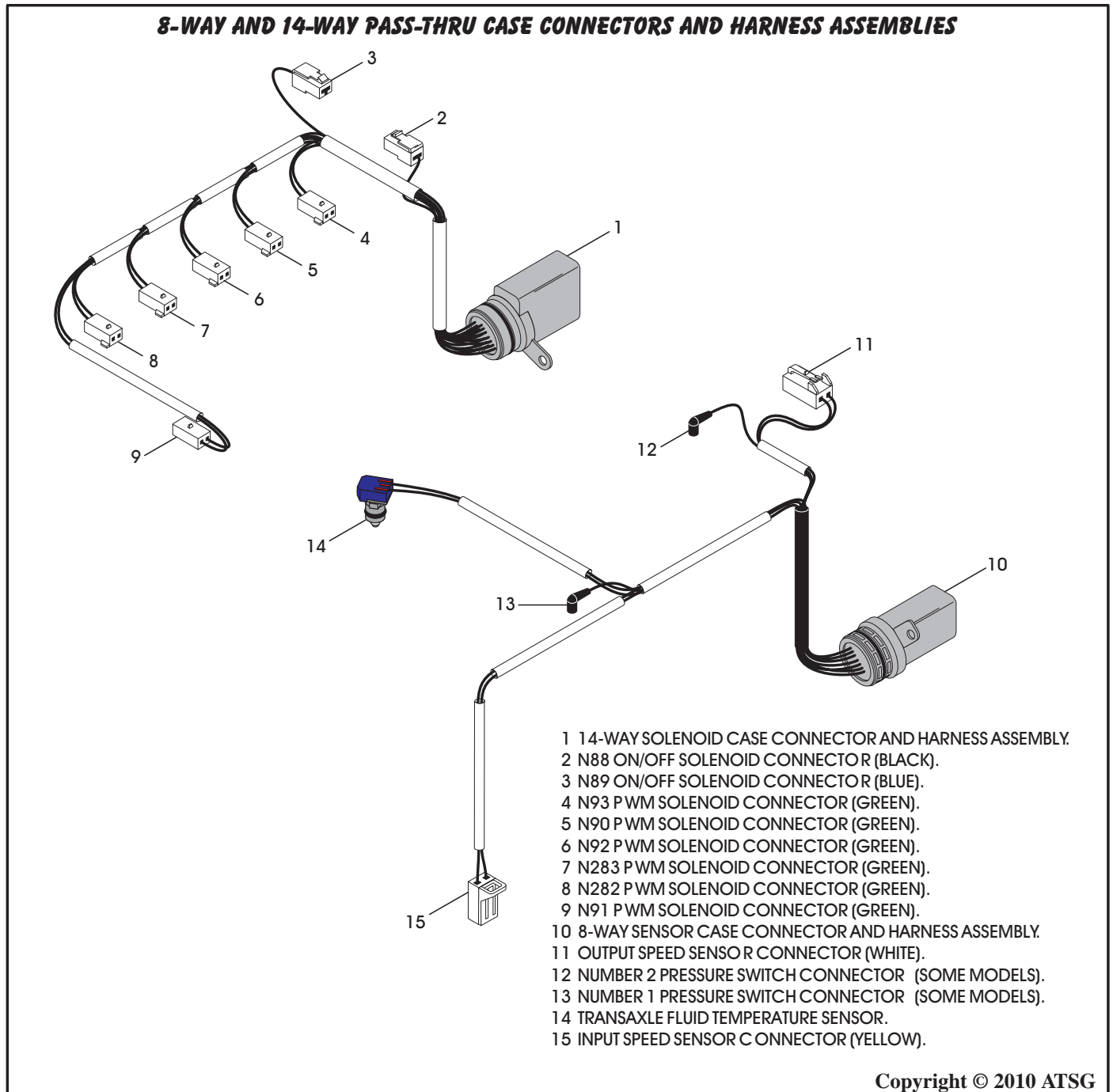

Figure 18

ELECTRONIC COMPONENTS (CONT'D)

Pass-Thru Case Connectors (Cont'd)

Both pass-thru case connectors are located on the right rear of the transmission case and both are retained with a single bolt, as shown in Figure 19.

Refer to Figure 19 for terminal identification of the 14-way and 8-way connectors. Resistance charts for the internal electronic components through the case connectors are shown in Figure 20. You can also check the same components through the TCM connector, which verifies the integrity of the wires all the way to the TCM in Figure 21.

Electronic Components Continued on Page 19

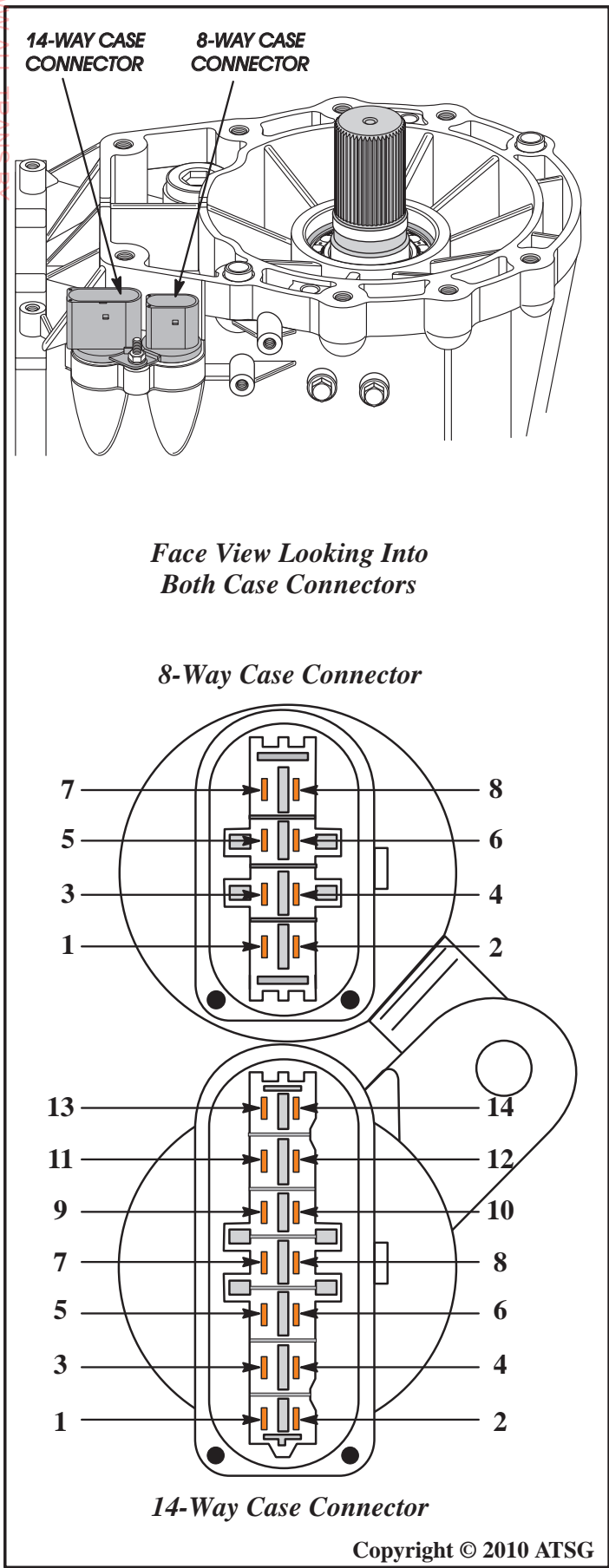

Figure 19



Technical Service Information

WWW.ALL-TRANS.BY

RESISTANCE CHART THROUGH 14-WAY CASE CONNECTOR

Solenoid Number (Name)	Positive Meter Lead Terminal No. (Wire Color)	Negative Meter Lead Terminal No. (Wire Color)	Ohms Resistance
Solenoid No. 1 (N88)	1 (White)	Case Ground	10.0 - 16.0
Solenoid No. 2 (N89)	2 (Black)	Case Ground	10.0 - 16.0
Solenoid No. 3 (N90)	7 (Purple)	8 (Yellow)	4.0 - 8.0
Solenoid No. 4 (N91)	11 (Lt. Green)	12 (Brown)	4.0 - 8.0
Solenoid No. 5 (N92)	3 (Yellow)	4 (Lt Blue)	4.0 - 8.0
Solenoid No. 6 (N93)	13 (Green)	14 (Grey)	4.0 - 8.0
Solenoid No. 9 (N282)	5 (Red)	6 (Blue)	4.0 - 8.0
Solenoid No. 10 (N283)	9 (White)	10 (Black)	4.0 - 8.0

When comparing resistance readings of On/Off solenoids, the resistance should be within .5 Ohms of one another.
 When comparing resistance readings of PWM solenoids, the resistance should be within .5 Ohms of one another.

RESISTANCE CHART THROUGH 8-WAY CASE CONNECTOR

Sensor ID (Name)	Positive Lead Term. No. (Color)	Negative Lead Term. No. (Color)	Temperature F° (C°)	Ohms Resistance
TFT (G93)	1 (Orange)	2 (Orange)	-22°F (-30°C)	37K - 51K Ohms
			50°F (10°C)	5K - 8K Ohms
			77°F (25°C)	3K - 5K Ohms
			230°F (110°C)	230 - 265 Ohms
			293°F (145°C)	100 - 120 Ohms
ISS (G182)	3 (White)	4 (Red)	77°F (25°C)	5.0M Ohms*
OSS (G195)	5 (Orange)	6 (Blue)	77°F (25°C)	5.0M Ohms*
PS1 (G193)	7 (Black)**	Case Ground		0 = Open
PS2 (G194)	8 (Yellow)**	Case Ground		0 = Open

* The ISS and OSS are Hall Effect Sensors and should be checked using a scope under operating conditions. The resistance values provided in the chart are from new sensors. Resistance checks on these type of sensors would, at best, inform you of either open or grounded circuits within the sensor itself.

** Pressure switches are not used in all models of the 09D transmission.

Wire colors provided in these charts are "Observed Internal" colors.

Copyright © 2010 ATSG

Figure 20

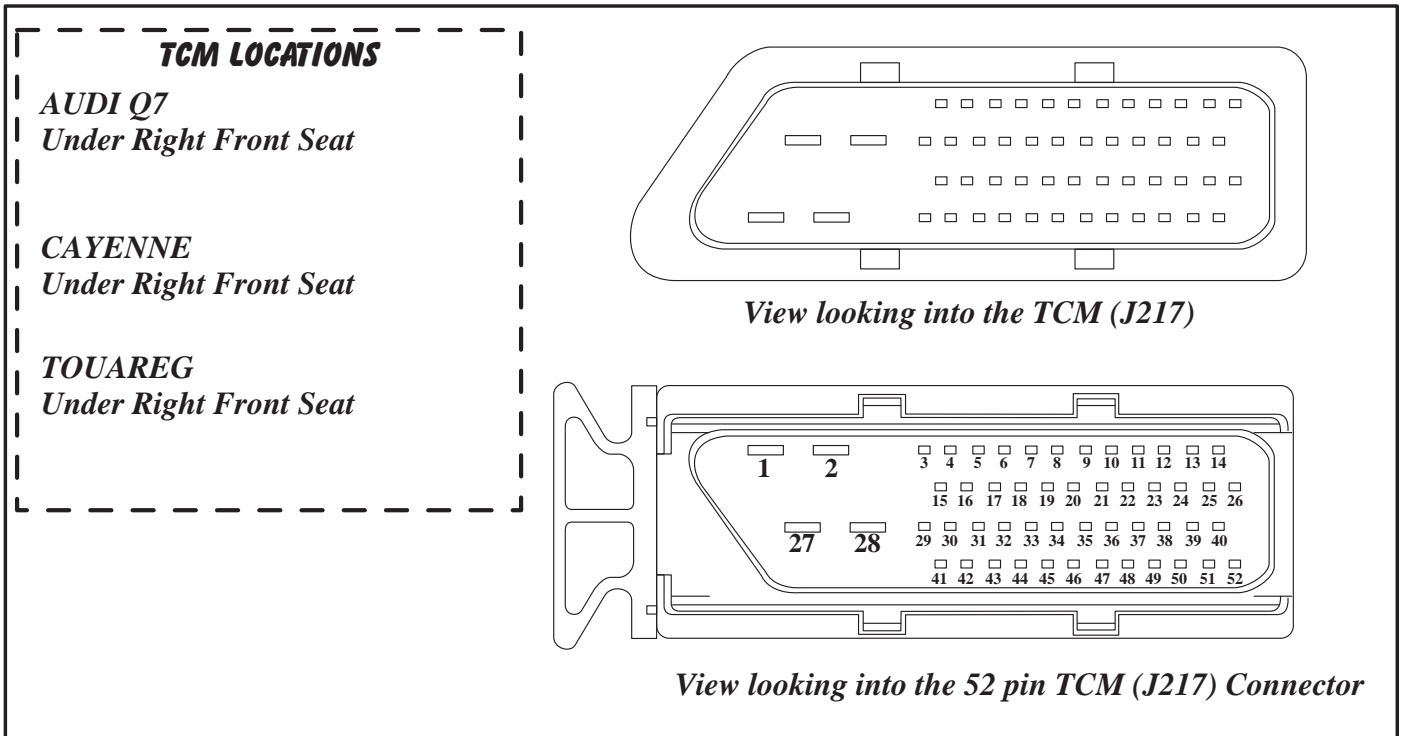

RESISTANCE CHART THROUGH TCM 52-WAY CONNECTOR

Solenoid Number (Name)	Positive Meter Lead Terminal No. (Wire Color)	Negative Meter Lead Terminal No. (Wire Color)	Ohms Resistance
Solenoid No. 1 (N88)	41 (Violet/Blue)	1 or 2 (Brown)	10 - 16
Solenoid No. 2 (N89)	15 (Violet/Green)	1 or 2 (Brown)	10 - 16
Solenoid No. 3 (N90)	18 (Violet/Gray)	30 (Yellow/Gray)	4.0-8.0
Solenoid No. 4 (N91)	5 (Brown)	43 (Gray/Black)	4.0-8.0
Solenoid No. 5 (N92)	42 (Yellow/Violet)	6 (Blue/White)	4.0-8.0
Solenoid No. 6 (N93)	31 (Blue/Violet)	17 (Green/Blue)	4.0-8.0
Solenoid No. 9 (N282)	16 (Yellow/Green)	32 (Violet)	4.0-8.0
Solenoid No. 10 (N283)	4 (Green)	44 (Yellow/Black)	4.0-8.0
TFT (G93)	45 (Blue/Brown)	8 (Blue/Black)	See Figure 20
ISS (G182)	51 (Green)	39 (Black)	5.0M
OSS (G195)	38 (Black/Brown)	50 (White)	5.0M
PS-1 (G193)	24 (Green/Blue)	1 or 2 (Brown)	0 = Open
PS-2 (G194)	25 (Blue/Green)	1 or 2 (Brown)	0 = Open

External Harness wire colors provided in the chart above may vary depending on the year, make and model of the vehicle.

Figure 21

ELECTRONIC COMPONENTS (CONT'D)

Transmission Range Switch (Multifunction F125)

The Transmission Range Switch (TRS) is located on the right hand side of the transmission, as shown in Figure 23. The TRS is a mechanical multi-position switch with 6 sliding contacts, four selector position switches, one reverse switch and one switch for positions P/N, for starting control.

The TRS is shown in Figure 22 and if removed or replaced, a position to the selector (manual) shaft must be set using special tool from Volkswagen.

Diagnosis

The only ignition voltage sent to the switch goes in at terminal 10 and goes through only the reverse switch, as shown in Figure 24. Voltage exits through terminal 8 and is sent to the reverse lamps and the TCM. Diagnosis here is easily done using a volt meter.

Diagnosis (Cont'd)

The remainder of the switches provide a ground signal for the starter relay through the P/N switch and ground signal to the TCM through the position switches, as shown in Figure 24. These switches must be checked with the DVOM set to Ohms. Notice in Figure 24 that terminals 3 and 4 provide the ground into the switches. Use the Ohm meter across terminals 4 and 2 to check for the Park and Neutral positions, as shown in the chart provided in Figure 24. With the Ohm meter on terminal 3, you should have continuity across the terminals shown in the chart in Figure 24, related to the position of the gear selector lever.

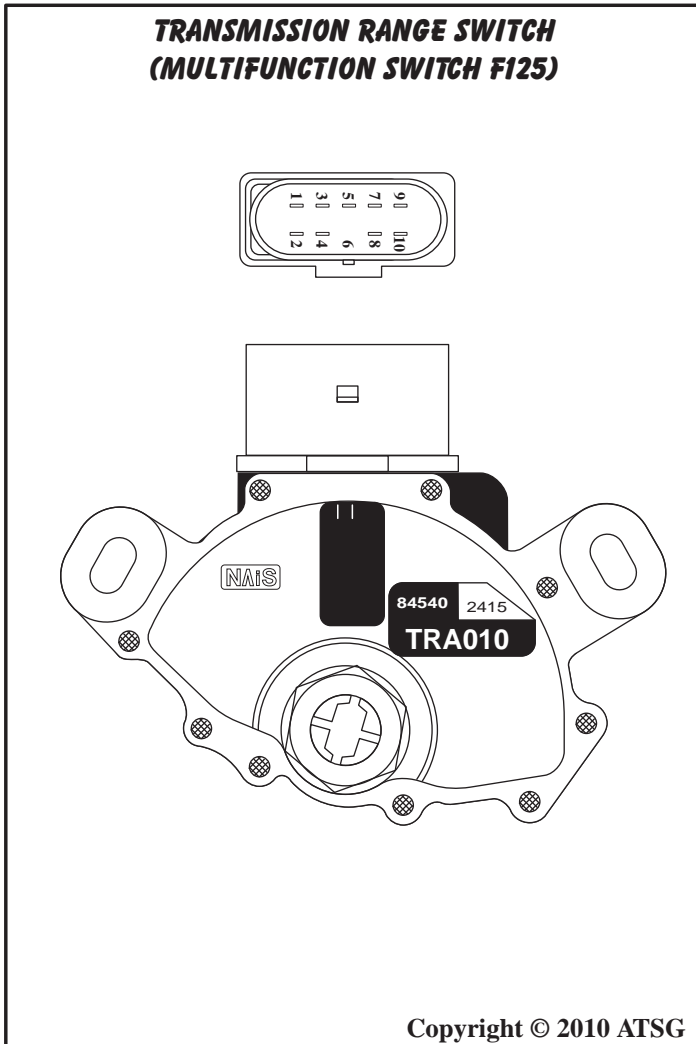

Figure 22

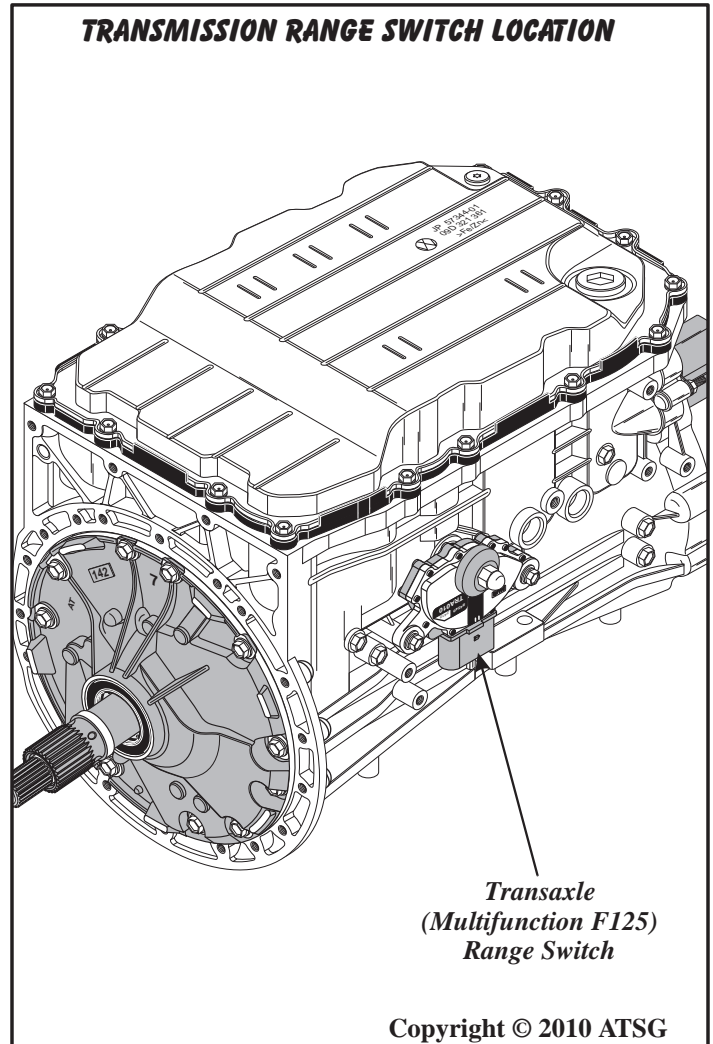
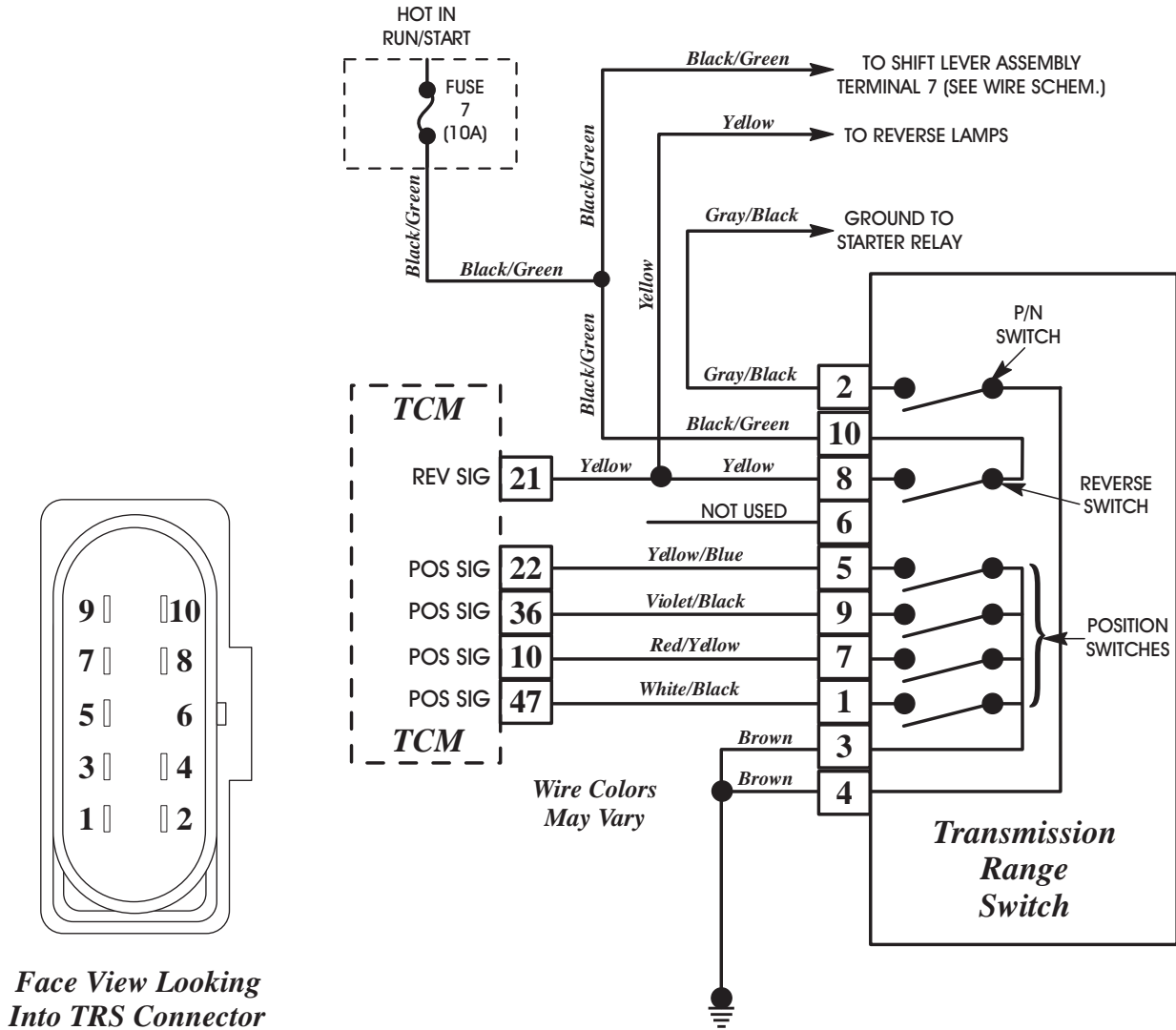

Figure 23

TRANSMISSION RANGE SWITCH SCHEMATIC



Face View Looking Into TRS Connector

Lever	P/N Signal		Rev Signal		Position Signal					Data Block 9.4 Value	
	2	4	10	8	3	1	7	9	5	Switch Position	Transition Position
P	●	●			●	●			●	1001	1101
R			●	●	●	●	●			1101	1101
N	●	●			●		●		●	0101	0111
D					●	●	●	●		0110	0111
S					●	●	●	●	●	1111	

Figure 24

SHIFT QUADRANTS

Selector Lever

The appearance of the selector lever, as shown in Figure 25, will vary between the different vehicle applications. However, the operation and function remains the same with the use of the TR-60SN.

Steering Wheel Paddles

Steering wheel paddles are available as options, as shown in Figure 25, and they also will vary in appearance with the different vehicle applications. However, operation and function remains the same with the TR-60SN.

Selector Lever Positions

P When the "Park" position is selected, there is no powerflow through the transmission. The parking pawl is engaged which locks the output shaft to the case. The engine can be started and the ignition key can be removed.

R When the "Reverse" position is selected, the vehicle can be operated in a rearward direction at a reduced gear ratio.

N When the "Neutral" position is selected, there is no powerflow through the transmission. The output shaft is not held and is free to rotate and the engine can be started. This position can also be selected while the vehicle is moving, to restart the engine if that becomes necessary.

D The "Drive" position is the normal position for most forward gear operations. The Drive position provides automatic upshifts and downshifts, apply and release of the converter clutch, and maximum fuel economy during normal operation. Drive range allows the transmission to operate in each of the six forward gear ratios. Downshifts are available for safe passing, by depressing the accelerator.

The "Tiptronic" in the Touareg is available in the selector lever as well as the steering wheel, by moving the selector lever to the right out of the "D" position.

S When the "Sport" position is selected, the lock button must be pressed to shift into "S", the TCM will select gears automatically using a performance oriented shifting program.

When the shift lever in the "S" position and moved into the right hand selector gate, it enables the driver to select the range of gears by tapping the selector lever towards the "-" or "+" to cause the transaxle to downshift or upshift.

S - Cont'd

On models equipped with the steering wheel paddles, the paddles are used to upshift and downshift the transmission manually, instead of the shift lever.

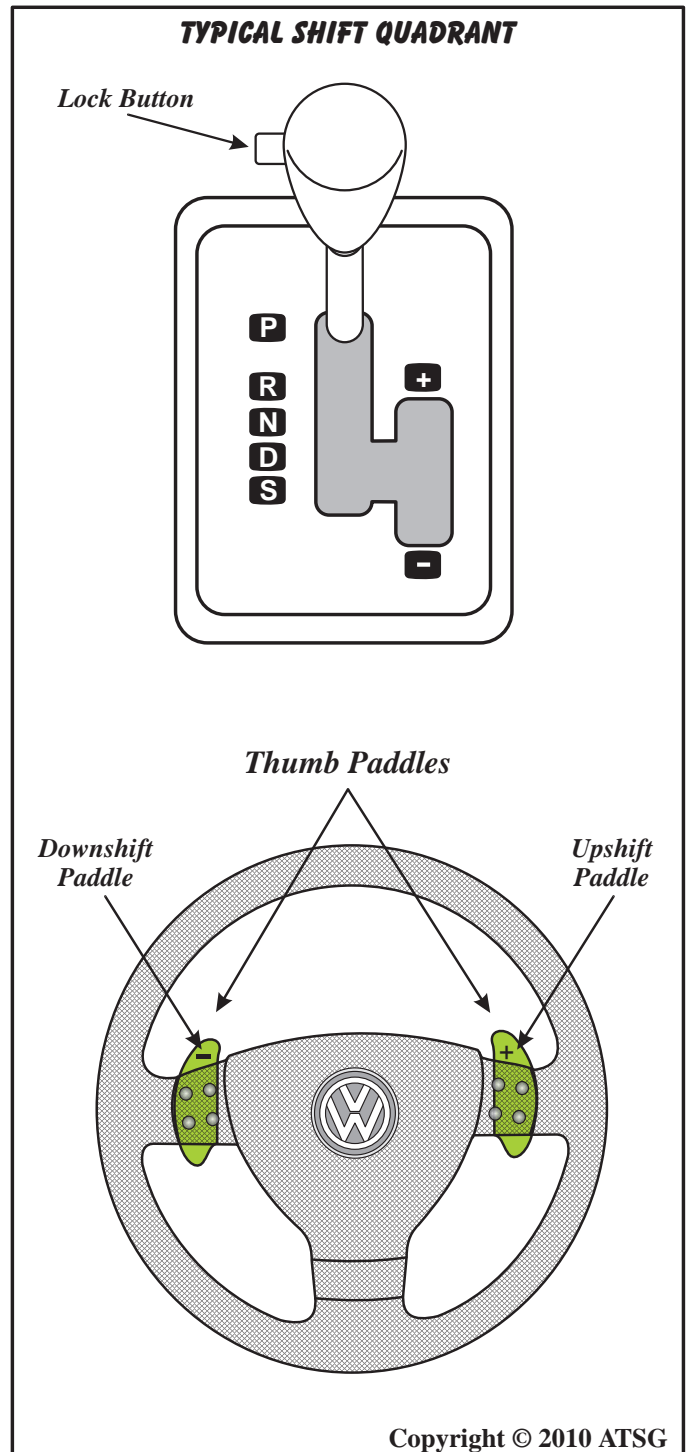

Figure 25

TIPTRONIC UPSHIFT AND DOWNSHIFT

Steering Wheel Paddles

Steering wheel paddles are available as options, as shown in Figure 25, and they also will vary in appearance with the different vehicle applications. However, operation and function remains the same with the TF-60SN. These operational paddles are found in the steering wheel on the left and right hand side, as shown in Figure 25.

Upshifts and downshifts occur by tapping the appropriate paddle. The shift signals are an input to the TCM, which in turn carries out the request.

If the Tiptronic paddles in the steering wheel are operated while in automatic mode, the TCM enters "Tiptronic Mode". If the paddles are not operated, the TCM returns to the automatic mode after a preprogrammed amount of time.

In case of a signal failure, no Tiptronic functions are possible using the steering wheel paddles.

Tiptronic Shifting Strategy

- - Automatic upshifts when the maximum RPM is reached.
- - Automatic downshifts when the RPM falls below the programmed minimum RPM.
- - Kickdown shifting available.
- - Acceleration from standing start in second gear by selecting 2nd before accelerating.
- - Upshift or downshift prevention.

LED Display On Instrument Panel

These vehicles are also equipped with an LED display on the instrument panel that will display the gear selected with the selector lever, as shown in Figure 26.

When the vehicle is first started, the display will be "P", as shown in Figure 26. If reverse is selected the "R" will be displayed.

When Drive is selected for the automatic forward mode the "D" will be displayed momentarily and will then go to "1", as you are still in first gear. As you are driving, the gear that the transaxle is in will be displayed on the instrument panel.

When in the Tiptronic Mode, the gear selected by pressing the paddles will be displayed in the instrument panel. Keep in mind that 2nd gear starts can be achieved using this feature. 3rd gear standing starts are not allowed.

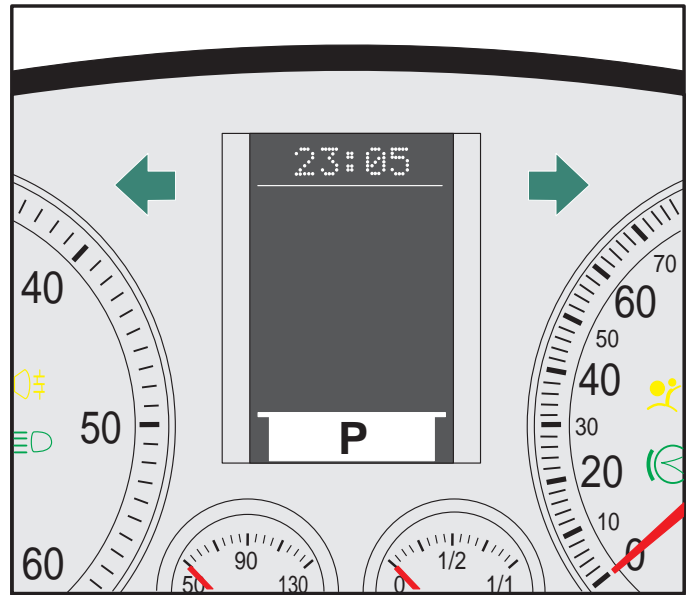

Figure 26

Emergency "Limp" Mode

In mechanical emergency running mode, 3rd gear is always engaged. If the transmission is already in 4th, 5th or 6th gear, the current gear is maintained until the selector lever is placed into the neutral position and the engine is stopped.

When starting off, 3rd gear is always engaged whether the selector lever is in the D or S position. Reverse is available.

System pressure is controlled to the maximum value; the shifting elements are pressurized to maximum shifting pressure. This results in a hard shift when engaging the driving mode. The torque converter lock-up clutch remains off.

Towing Restrictions

When towing, the ATF pump is not operated, and therefore rotating components are not lubricated. To avoid severe damage to the transaxle, the following conditions **must** be met:

- - The selector lever must be in the "N" Neutral position.
- - Towing speed must not exceed 31 mph (50km/h).
- - Vehicle must not be towed further than 31 miles (50 km).

TYPICAL VOLKSWAGEN/AUDI WIRE SCHEMATIC

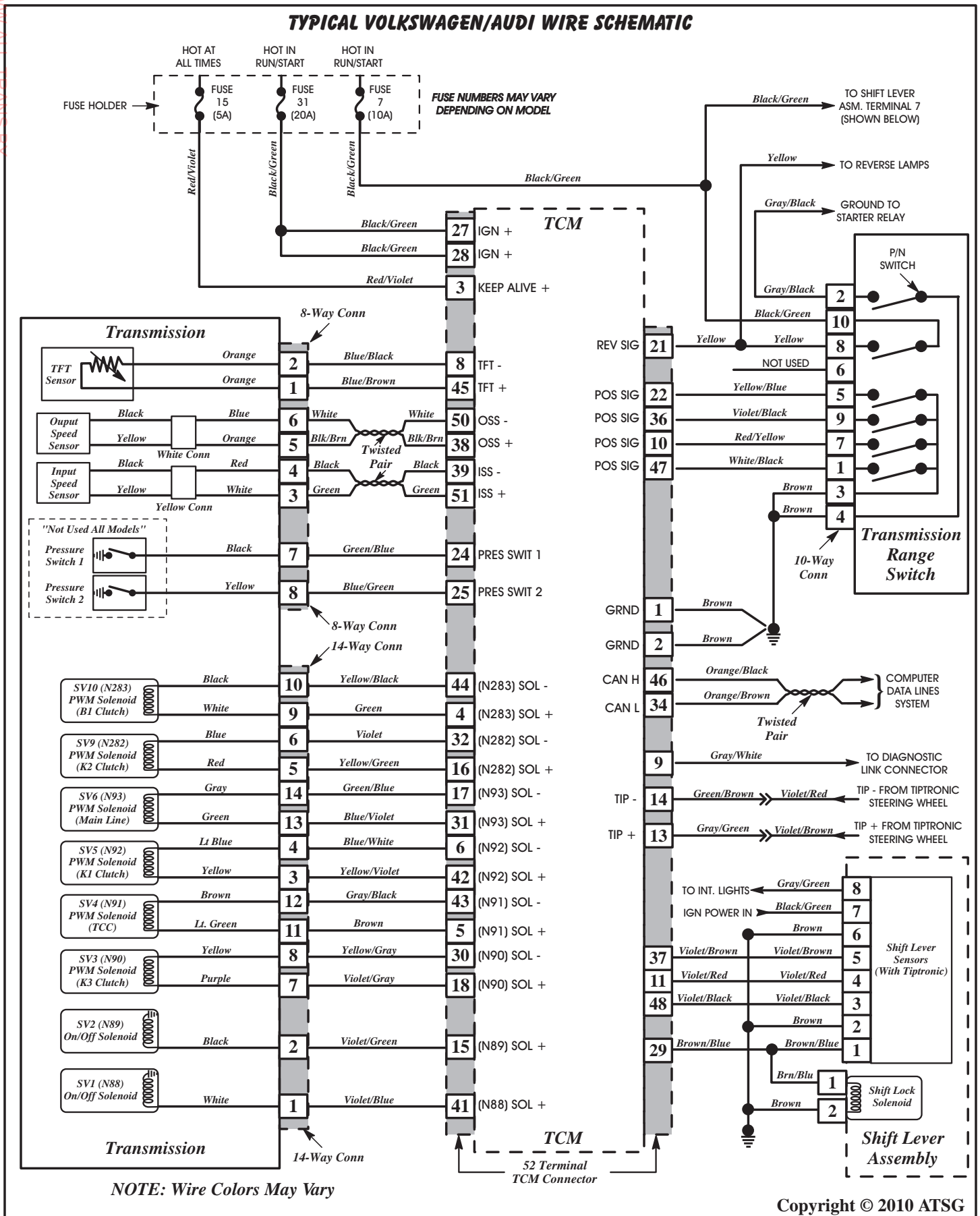

Figure 27



Technical Service Information

WWW.ALL-TRANS.BY

VOLKSWAGEN "VAG" DIAGNOSTIC TROUBLE CODES

VAG	DESCRIPTION
00258	<i>N88-SV1 Shift Solenoid 1, Circuit Error (Open or Short)</i>
00260	<i>N89-SV2 Shift Solenoid 2, Circuit Error (Open or Short)</i>
00262	<i>N90- SV3 K3 Control Solenoid Circuit Error (Open or Short)</i>
00264	<i>N91-SV4 Torque Converter Clutch PWM Solenoid, Circuit Error (Open or Short)</i>
00266	<i>N92-SV5, K1 Control Solenoid Circuit Error (Open or Short)</i>
00268	<i>N93-SV6 Pressure Control Solenoid, Circuit Error (Open or Short)</i>
00293	<i>Transaxle Range (TR) switch F125, circuit malfunction (Implausible signal)</i>
00300	<i>Transmission Fluid Temp, (G93) circuit malfunction (Open or Short)</i>
00348	<i>N282-SV9, K2 Control Solenoid Circuit Error (Open or Short)</i>
00349	<i>N283-SV10, B1 Control Solenoid Circuit Error (Open or Short)</i>
00364	<i>System Voltage too Low</i>
00453	<i>Function restriction because of excess Trans Fluid Temp.</i>
00529	<i>TCM to ECM Error, No Engine Speed Signal G28</i>
00541	<i>ATF temp too high</i>
00777	<i>Throttle Position Sensor, No Signal CAN bus connection interrupted</i>
01045	<i>Tiptronic Switch F189 implausible signal</i>
01166	<i>Engine Torque signal no signal from ECM</i>
01192	<i>Torque Converter Clutch mechanical fault (slip)</i>
01236	<i>Selector Lever Lock Solenoid, Circuit Error N110 (Open or Short)</i>
01312	<i>Drive Train Data Bus Fault, No Communication</i>
01314	<i>Engine Control Module, DTC present</i>
01316	<i>ABS Module, No Communication, or ignition switched on with TCM unplugged</i>
01679	<i>Speed signal from ABS Front Left wheel implausible</i>
01680	<i>Speed signal from ABS Front Right wheel implausible</i>
01681	<i>Speed signal from ABS Rear Left wheel implausible</i>
01682	<i>Speed signal from ABS Rear Right wheel implausible</i>
01683	<i>Wheel speed signals/vehicle speed implausible</i>
65535	<i>Control Module Faulty, (TCM)</i>

Copyright © 2010 ATSG

Figure 28

VOLKSWAGEN "VAG" TO OBD11 DIAGNOSTIC TROUBLE CODES		
VAG	OBD11	DESCRIPTION
16988	P0604	<i>TCM faulty</i>
16989	P0605	<i>TCM faulty</i>
16997	P0613	<i>TCM faulty</i>
17084	P0700	<i>TCM faulty</i>
17089	P0705	<i>Multifunction Trans Range sensor F125 electrical fault</i>
17090	P0706	<i>Multifunction Trans Range sensor F125 implausible signal</i>
17095	P0711	<i>Trans Fluid Temp G93 fault in electrical circuit</i>
17096	P0712	<i>Trans Fluid Temp G93 signal too low</i>
17097	P0713	<i>Trans Fluid Temp G93 signal too high</i>
17099	P0715	<i>Input Speed sensor G182 circuit fault</i>
17100	P0716	<i>Input Speed sensor G182 Implausible signal</i>
17101	P0717	<i>Input Speed sensor G182 no signal</i>
17105	P0721	<i>Output Speed sensor G195 circuit fault</i>
17109	P0725	<i>Engine Speed sensor G28 circuit fault from ECM</i>
17113	P0729	<i>Clutch of indicated gear is faulty (wrong ratio, slip)</i>
17114	P0730	<i>Clutch of indicated gear is faulty (wrong ratio, slip)</i>
17115	P0731	<i>1st Gear (wrong ratio, slip)</i>
17116	P0732	<i>2nd Gear (wrong ratio, slip)</i>
17117	P0733	<i>3rd Gear (wrong ratio, slip)</i>
17118	P0734	<i>4th Gear (wrong ratio, slip)</i>
17119	P0735	<i>5th Gear (wrong ratio, slip)</i>
17132	P0748	<i>N91-SV4 Torque Converter Clutch PWM Solenoid, Circuit (Open or Short)</i>
17135	P0751	<i>N88-SV1 Shift Solenoid 1, Circuit Error (Open or Short to ground)</i>
17136	P0752	<i>N88-SV1 Shift Solenoid 1, Circuit Error (Short to Battery voltage)</i>
17137	P0753	<i>N88-SV1 Shift Solenoid 1, Electrical Circuit fault</i>
17140	P0756	<i>N89-SV2 Shift Solenoid 2, Circuit Error (Open or Short to ground)</i>
17141	P0757	<i>N89-SV2 Shift Solenoid 2, Circuit Error (Short to Battery voltage)</i>
17182	P0798	<i>N93-SV6 Pressure control Circuit Error (Open or Short)</i>
17195	P0811	<i>Heavy Clutch Slip</i>
17224	P0840	<i>Trans pressure sensor 1 G193 mechanical fault (model dependant)</i>
17225	P0841	<i>Trans pressure sensor 1 G193 open or short/implausible (model dependant)</i>
17226	P0842	<i>Trans pressure sensor 1 G193 short to ground (model dependant)</i>
17299	P0845	<i>Trans pressure sensor 2 G194 mechanical fault (model dependant)</i>
17230	P0846	<i>Trans pressure sensor 2 G194 open or short/implausible (model dependant)</i>
17231	P0847	<i>Trans pressure sensor 2 G194 short to ground (model dependant)</i>

Copyright © 2010 ATSG

Figure 29

VOLKSWAGEN "VAG" TO OBD11 DIAGNOSTIC TROUBLE CODES		
VAG	OBD11	DESCRIPTION
18010	P1602	Voltage supply too low
18255	P1847	DTC in ABS problem
18554	P2122	Throttle position sensor signal too low G79
19146	P2714	N91-SV4 Torque Converter Clutch PWM Solenoid, Circuit (Open or Short)
19147	P2715	N91-SV4 Torque Converter Clutch PWM Solenoid, Circuit (Short to B+)
19148	P2716	N91-SV4 Torque Converter Clutch PWM Solenoid, electrical circuit fault
19155	P2723	N92-SV5 K1 Clutch control Solenoid, Circuit (Open or Short)
19156	P2724	N92-SV5 K1 Clutch control Solenoid, Circuit (Short to B+)
19157	P2725	N92-SV5 K1 Clutch control Solenoid, electrical circuit fault
19164	P2732	N93-SV6 Pressure control Solenoid, Circuit (Open or Short)
19165	P2733	N93-SV6 Pressure control Solenoid, Circuit (Short to B+)
19166	P2734	N93-SV6 Pressure control Solenoid, electrical circuit fault
		Copyright © 2010 ATSG

Figure 30

LINE PRESSURE SPECIFICATIONS				
<i>"Observed" Pressure Specifications</i>				
Selector Lever	Taps Required	Specifications in psi		
		K1	K3	B2
"D" Idle	K1 & B2	54-60		0.9
"D" Idle (Tiptronic)	K1 & B2	104-106		23-28
"D" Stall*	K1 & B2	146-160		0.9
"D" Stall (Tiptronic)*	K1 & B2	187-190		53-55
"R" Idle	K3 & B2		80-85	80-85
"R" Stall*	K3 & B2		270-275	270-275
* "D" & "R" Stall, at approx 2300 rpm, the PCM cuts fuel to engine.				
<i>Other "Observed" Pressures</i>				
Lube Pressure 4-8 psi, 8-10 psi in 6th gear				
<p><i>Note: Pressure specifications listed in the chart above may vary slightly depending on year, engine size, vehicle model, and the TCM calibrations. Refer to Figure 32 for pressure tap locations.</i></p>				
Copyright © 2010 ATSG				

Figure 31

PRESSURE TAP LOCATIONS AND IDENTIFICATION

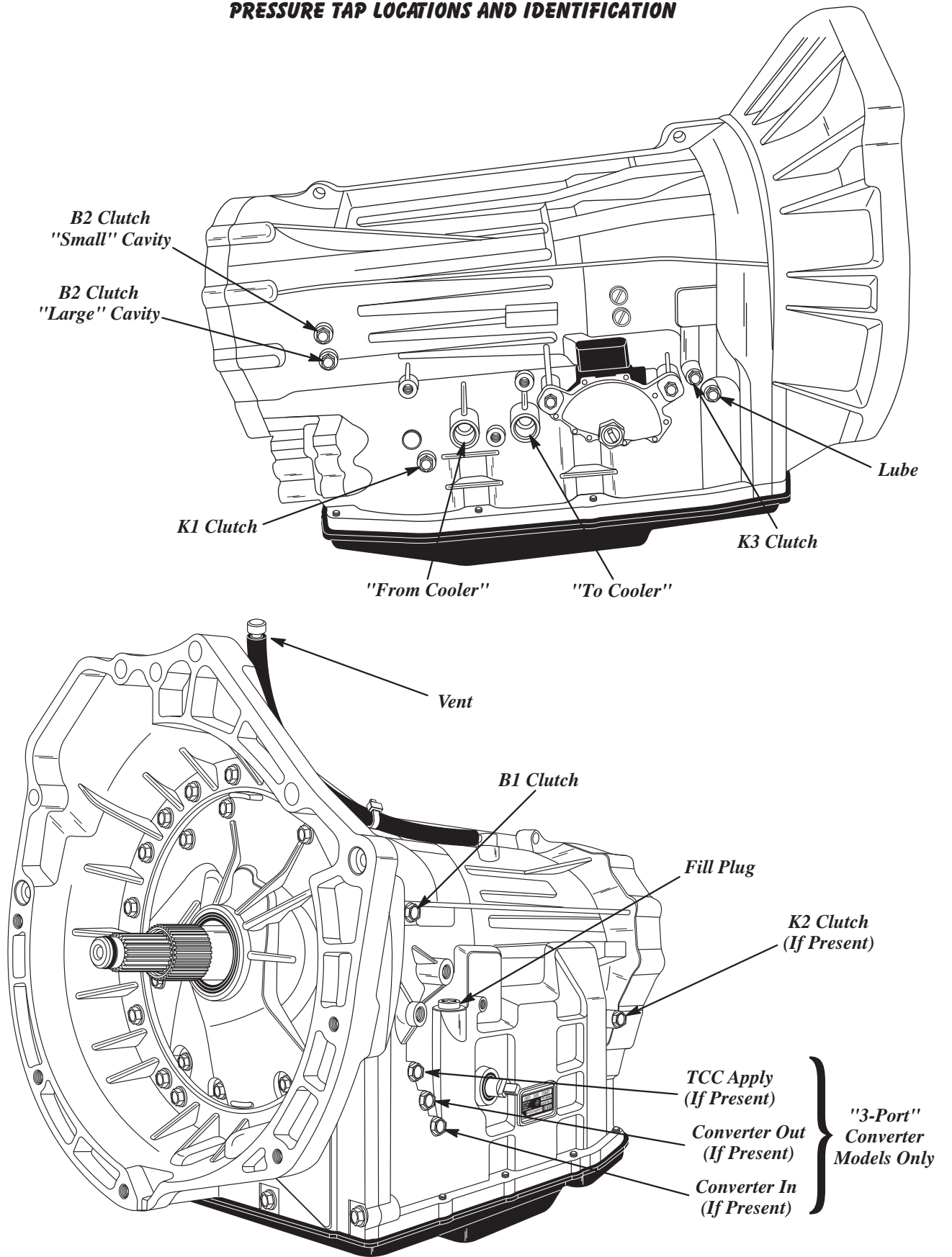

Copyright © 2010 ATSG

Figure 32

JW ALL-TRANS E

Case For 16 Bolt Oil Pan

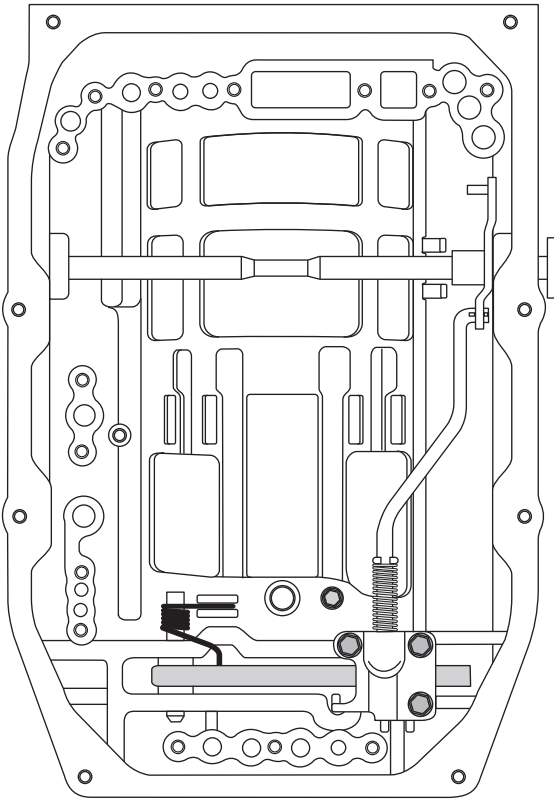

Case For 16 Bolt Oil Pan

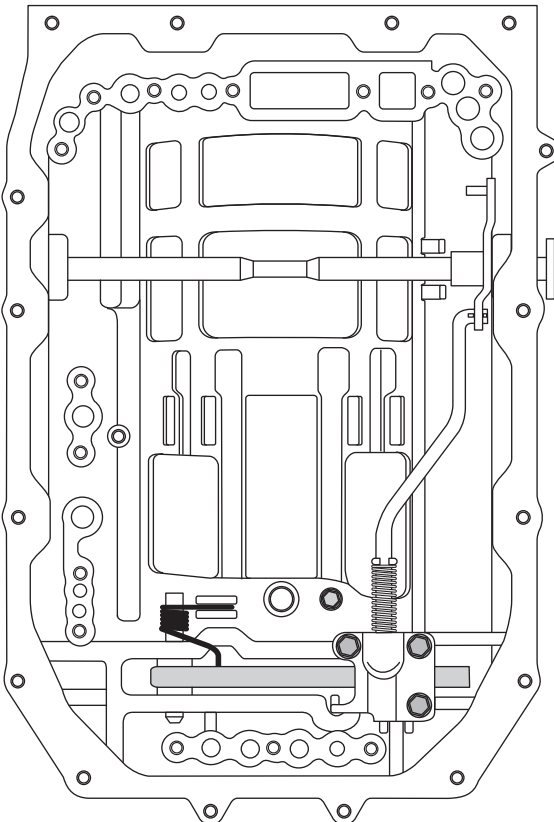

Copyright © 2010 ATSG

Figure 33

FLUID PASSAGE IDENTIFICATION

Transmission Case

We have seen 2 different styles of the transmission case in 2 different locations. First, the number of pan bolts vary between 8 and 16, as shown in Figure 33. Second, there is a variance on the converter housing side of the case, as shown in Figure 35 and 36. Notice in Figure 36 the pump suction and pressure passages that are fed outside the case and into the converter housing. This will also effect the converter housing as it will require 2 "O" ring seals between the case and converter housing, as shown in Figure 34.

The valve body side case passages are the same regardless of which case you have and passage identification is shown in Figure 37. Notice also in Figure 37, that the B2 clutch piston is a 2 cavity piston like the THM 400 direct piston. The B2 clutch piston requires 3 "O" ring seals.

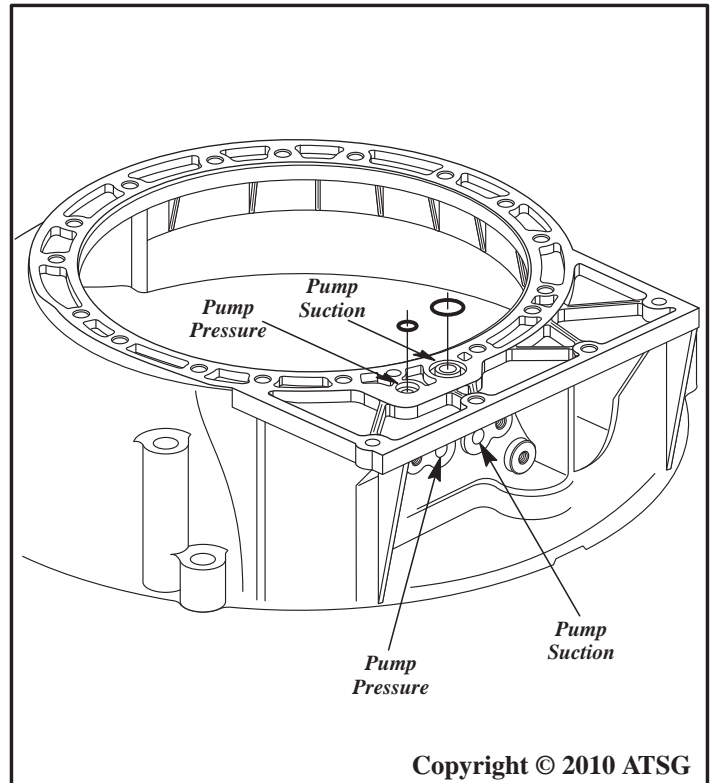

Copyright © 2010 ATSG

Figure 34

16 BOLT PAN CASE PASSAGE IDENTIFICATION, PUMP SIDE

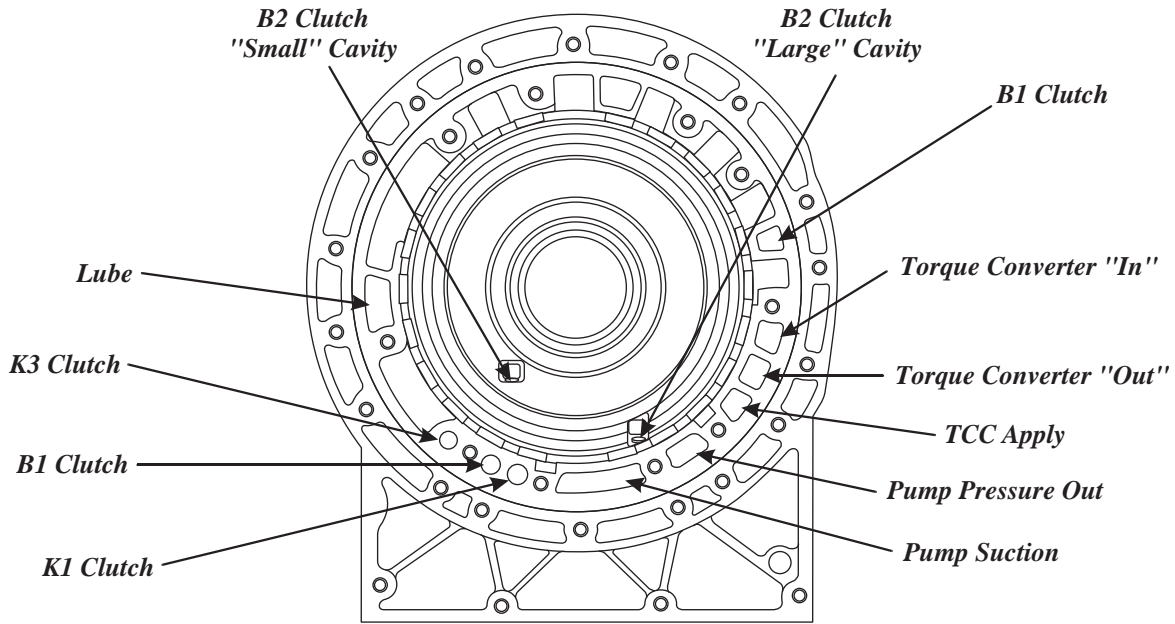

Copyright © 2010 ATSG

Figure 35

8 PAN BOLT CASE PASSAGE IDENTIFICATION, PUMP SIDE

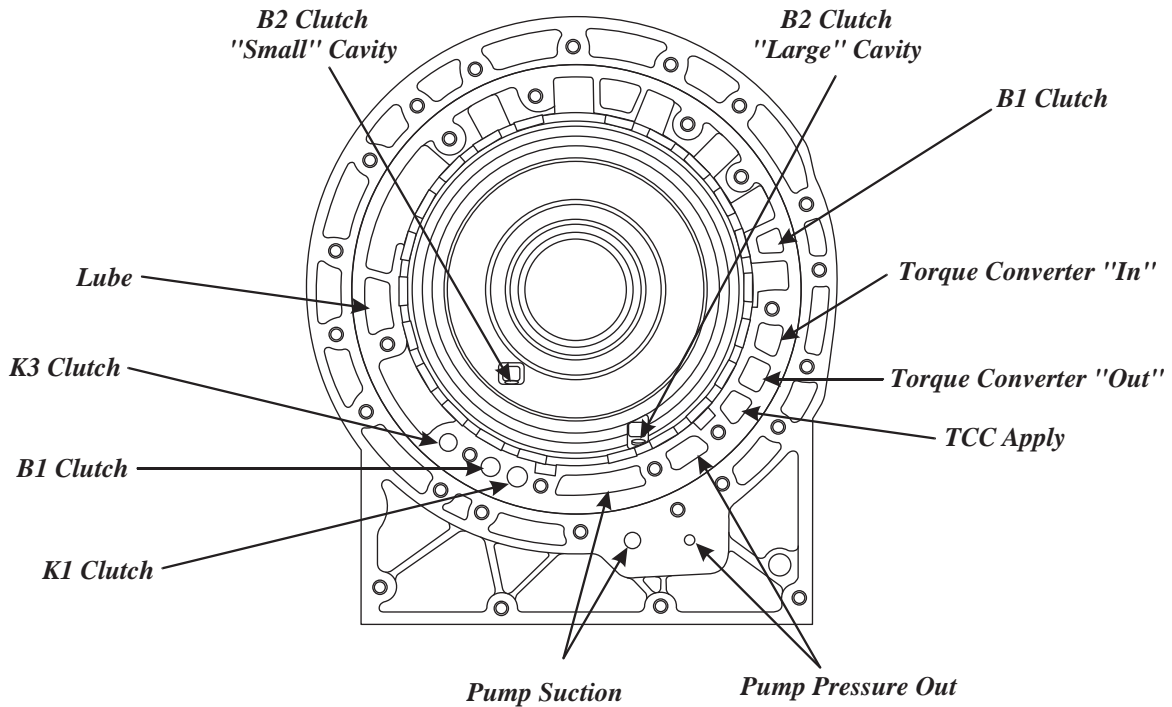

Copyright © 2010 ATSG

Figure 36

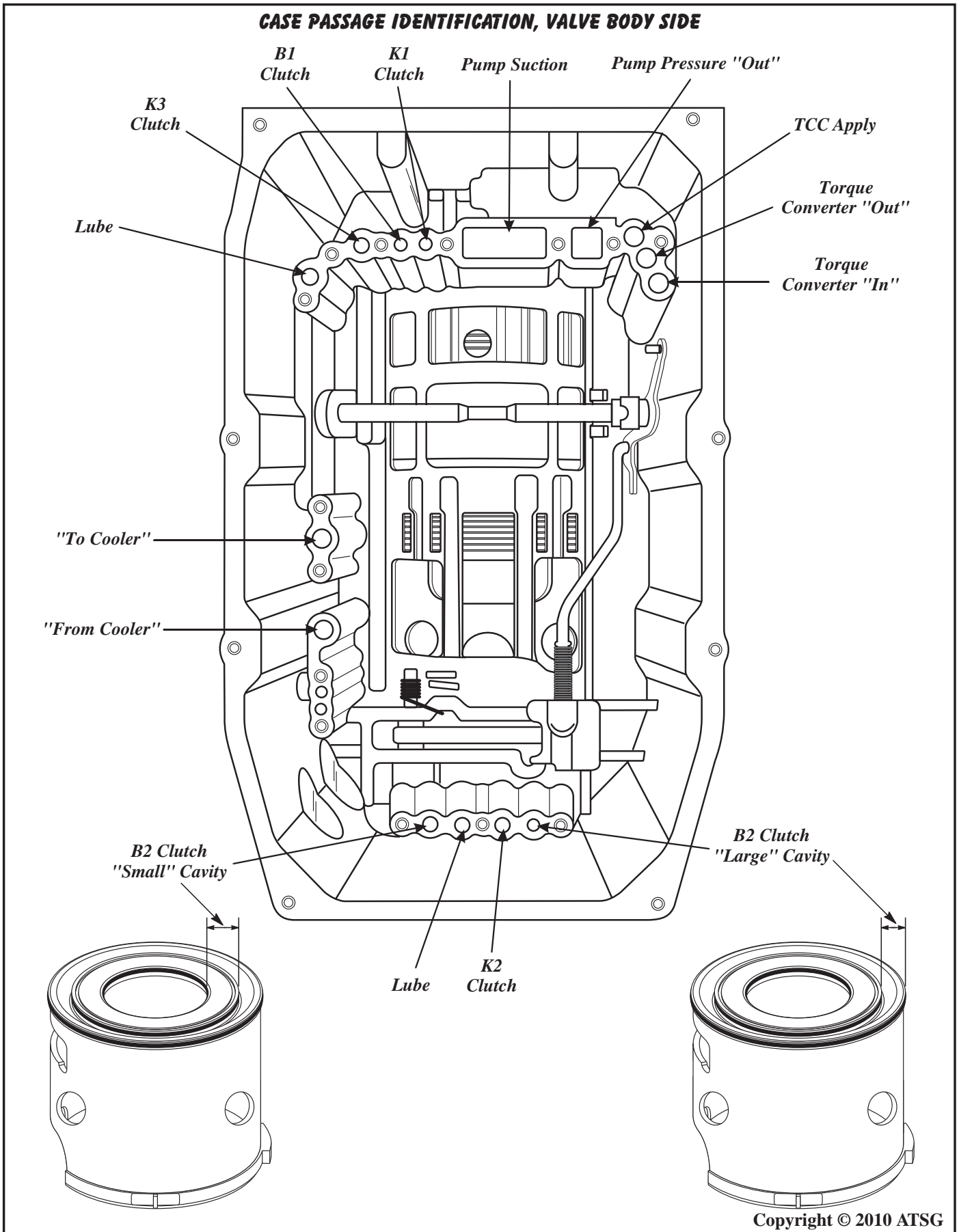

Figure 37

SAFETY PRECAUTIONS

Service information provided in this manual by ATSG is intended for use by professional, qualified technicians. Attempting repairs or service without the appropriate training, tools and equipment could cause injury to you or others.

The service procedures we recommend and describe in this manual are effective methods of performing service and repair on this unit. Some of the procedures require the use of special tools that are designed for specific purposes.

This manual contains CAUTIONS that you must observe carefully in order to reduce the risk of injury to yourself or others. This manual also contains NOTES that must be carefully followed in order to avoid improper service that may damage the vehicle, tools and/or equipment.

WARNING: At time of this printing, there are not any new "hard parts" available from the manufacturer for this unit. Only source will be used aftermarket suppliers.

TRANSMISSION DISASSEMBLY

Note: The illustrations provided in the Assembly and Disassembly section, are of a VW "09D" model with the 3 port converter, but procedures are the same on all "09D" models.

1. The transmission should be steam cleaned on the outside, to remove any dirt and grease before disassembly begins.
2. This transmission can be disassembled very easily on a work bench without the benefit of holding fixture for rotation.
3. Remove torque converter from transmission, as shown in Figure 38.
Caution: Use care when removing the torque converter, to avoid personal injury and/or damage to converter, as it is heavy.
4. Record the torque converter code letters, to determine 2 port or 3 port design, for future reference.

Continued on Page 32

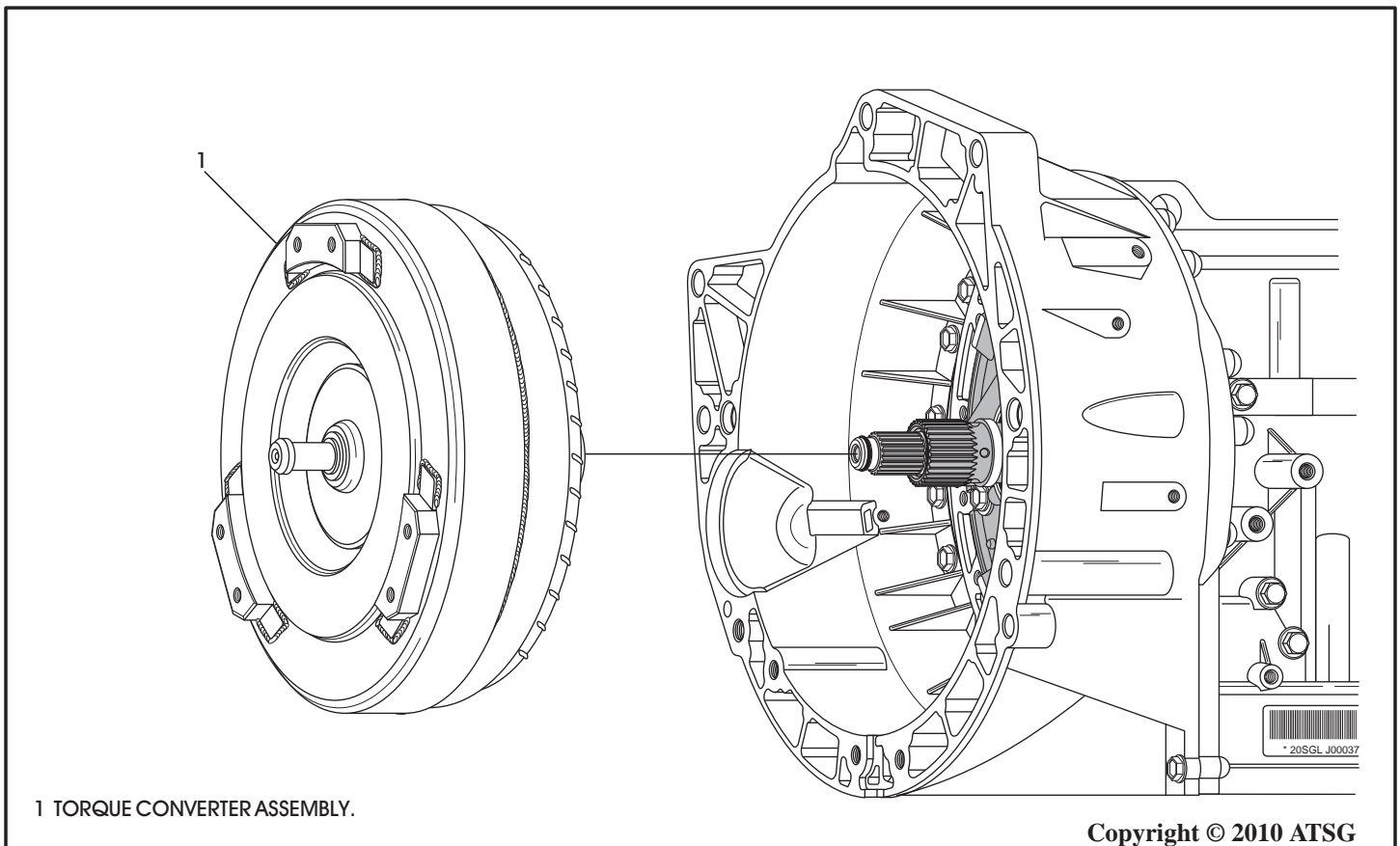

Figure 38

TRANSMISSION DISASSEMBLY (CONT'D)

5. Remove the 22 converter housing retaining bolts, which is the outer row, as shown in Figure 39, using a 12 MM socket.

Note: Four of the converter housing bolts are behind the face of housing, as shown in Figure 39.

6. Remove torque converter housing, as shown in Figure 40, by tapping with a mallet as necessary.

7. Remove and discard the turbine shaft "O" ring, as shown in Figure 40.

Note: Turbine shaft "O" ring is used on the 3 port converter models only.

Continued on Page 33

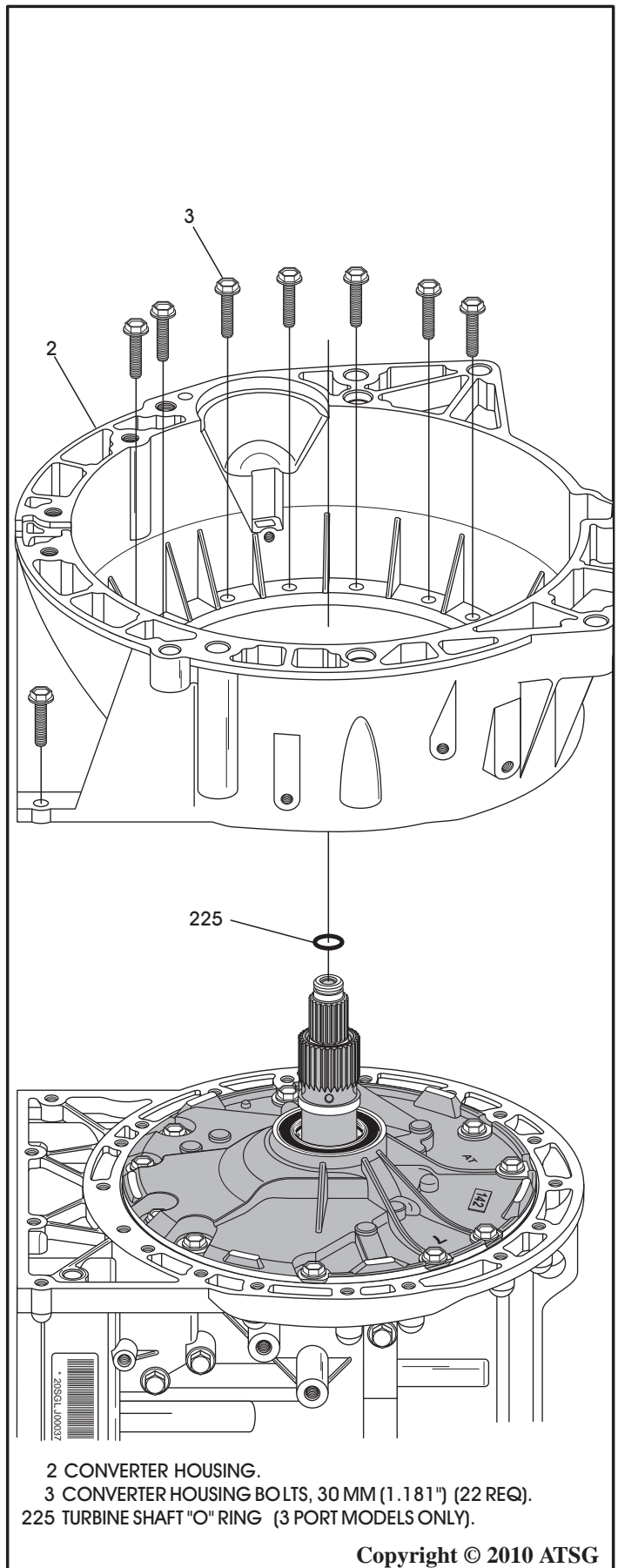

2 CONVERTER HOUSING.
 3 CONVERTER HOUSING BOLTS, 30 MM (1.181") (22 REQ).
 225 TURBINE SHAFT "O" RING (3 PORT MODELS ONLY).

Copyright © 2010 ATSG

Figure 40

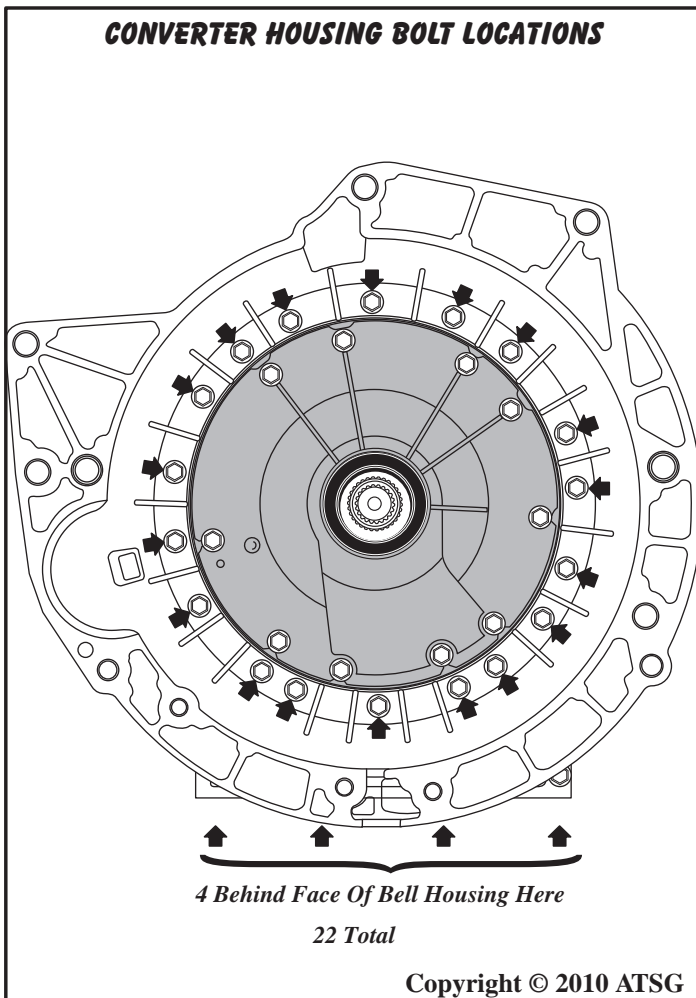

4 Behind Face Of Bell Housing Here
 22 Total

Copyright © 2010 ATSG

Figure 39

TRANSMISSION DISASSEMBLY (CONT'D)

8. Some models of the "09D" family route line pressure through the converter housing and will have two "O" ring seals on the back side of the converter housing, as shown in Figure 41.
9. Remove the acorn nut and debris shield from the transmission range (multifunction) switch, as shown in Figure 42.
10. Remove the two range switch retaining bolts, as shown in Figure 42, and slide TRS off of manual shaft.

Note: *If the range (multifunction) switch is removed or replaced, a position to the manual selector shaft must be set using a special tool available from Volkswagen.*

Continued on Page 34

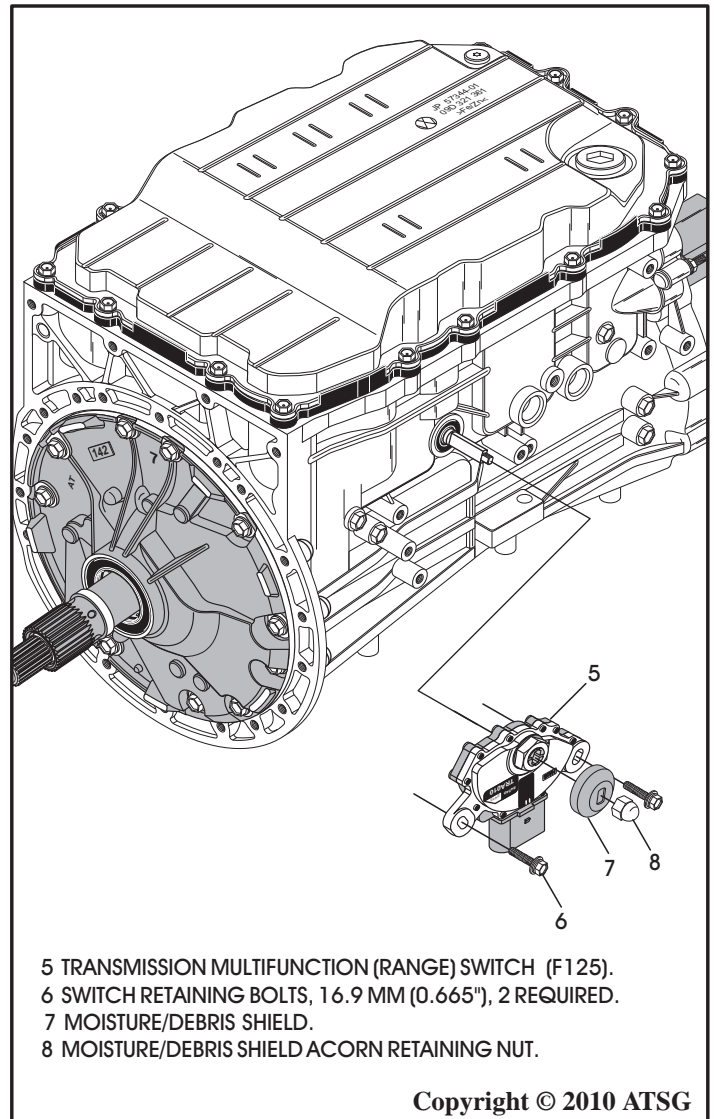

Figure 42

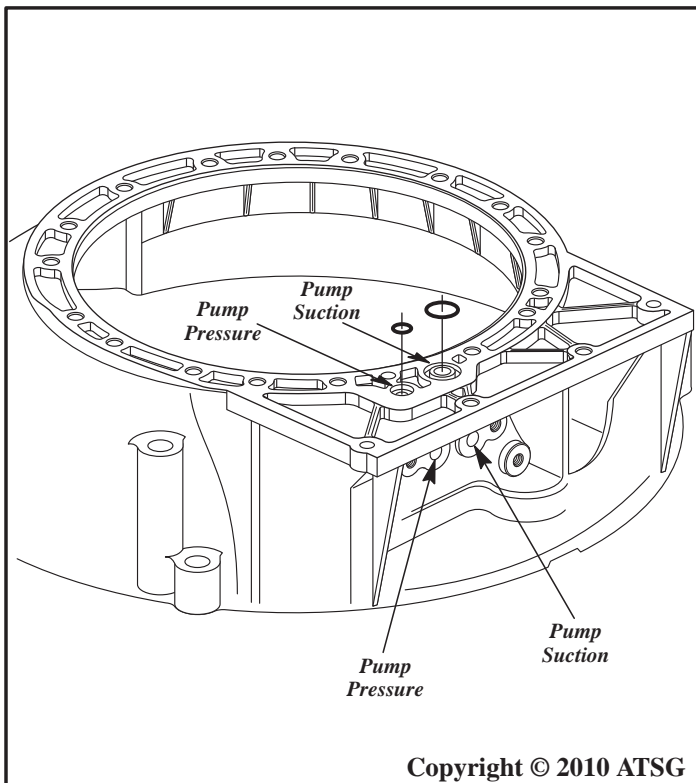

Figure 41

TRANSMISSION DISASSEMBLY (CONT'D)

11. If you are working on a 4WD model, you can remove the rear seal now or you can wait until you have the output shaft out as it is easier to remove at that point (See Figure 43).
12. However, if you are working on a 2WD model, you must remove the driveshaft yoke nut and the driveshaft yoke, as shown in Figure 44, before you can remove the output shaft.
13. Remove the eight mounting plate retaining bolts and the mounting plate, as shown in Figure 44.
14. Again, you can remove the rear seal now or wait until you have the output shaft out.

Continued on Page 35

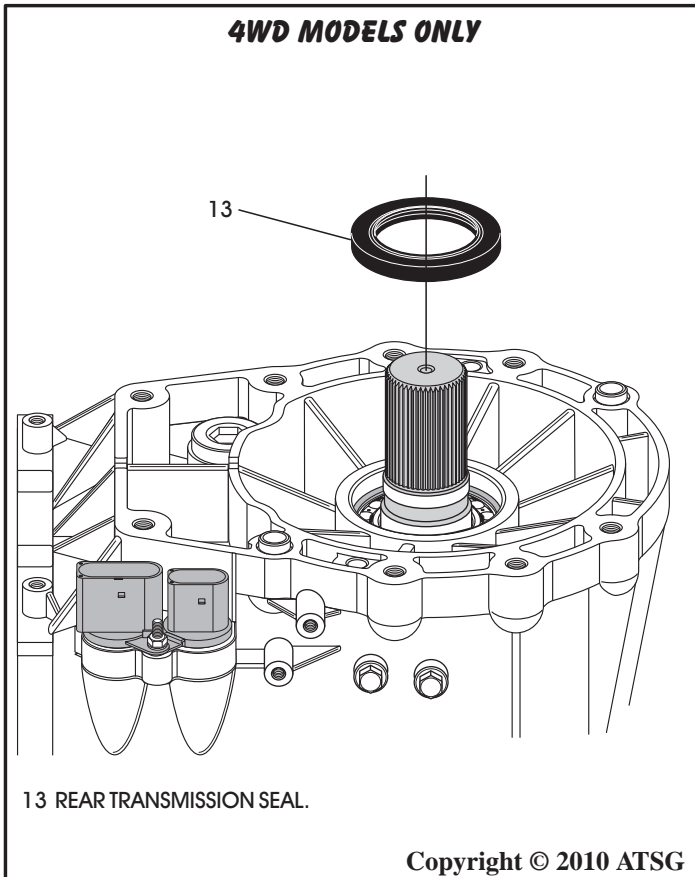

Figure 43

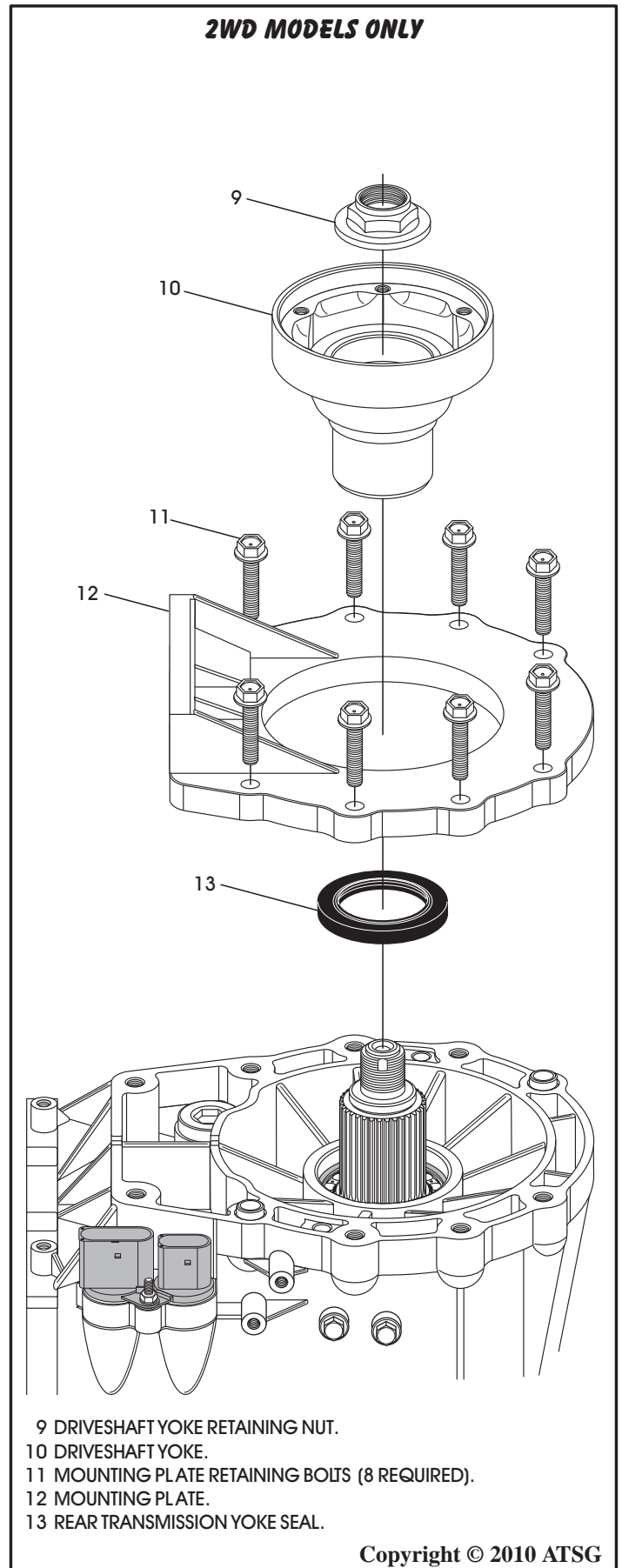

Figure 44

TRANSMISSION DISASSEMBLY (CONT'D)

15. Remove the oil pan and oil pan gasket, as shown in Figure 45.

Note: There are 2 different oil pans and cases, one version has 8 bolts and one has 16 bolts, as shown in Figure 33.

16. Remove the 3 filter retaining bolts and the oil filter, as shown in Figure 46.

17. Remove and discard the oil filter to valve body "O" ring seal, as shown in Figure 46.

Continued on Page 36

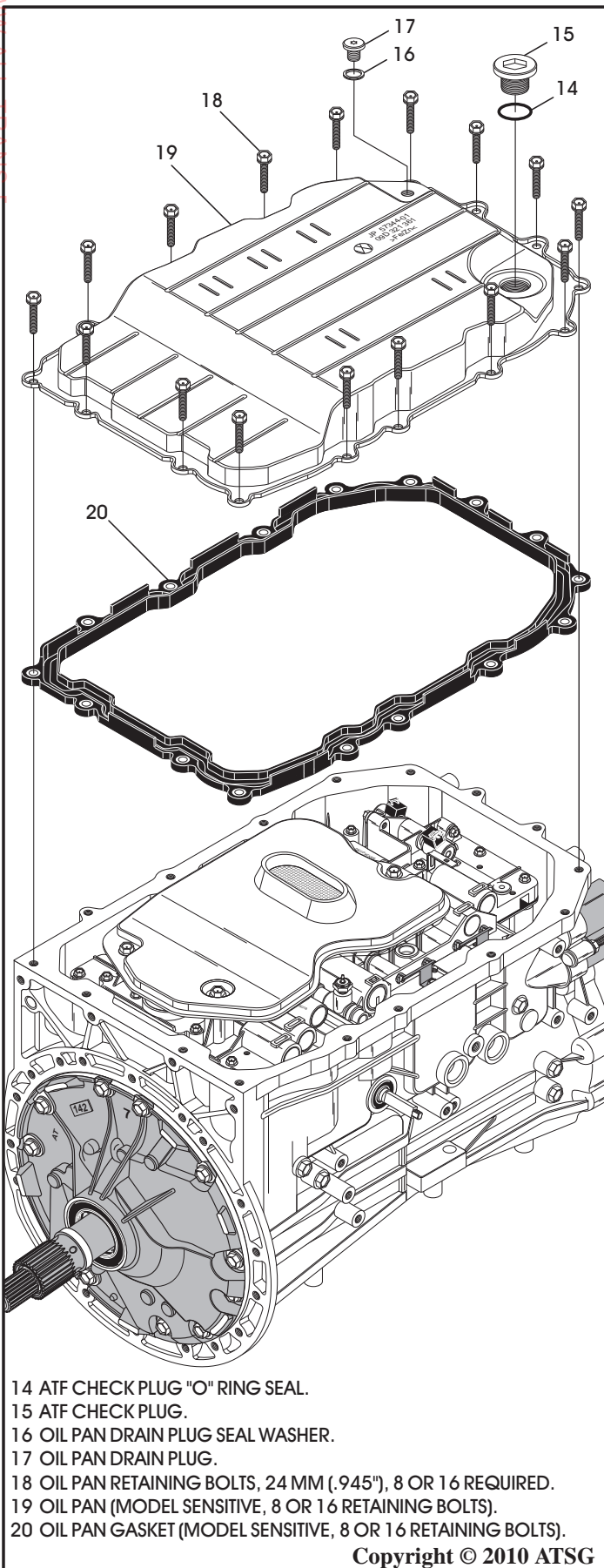

Figure 45

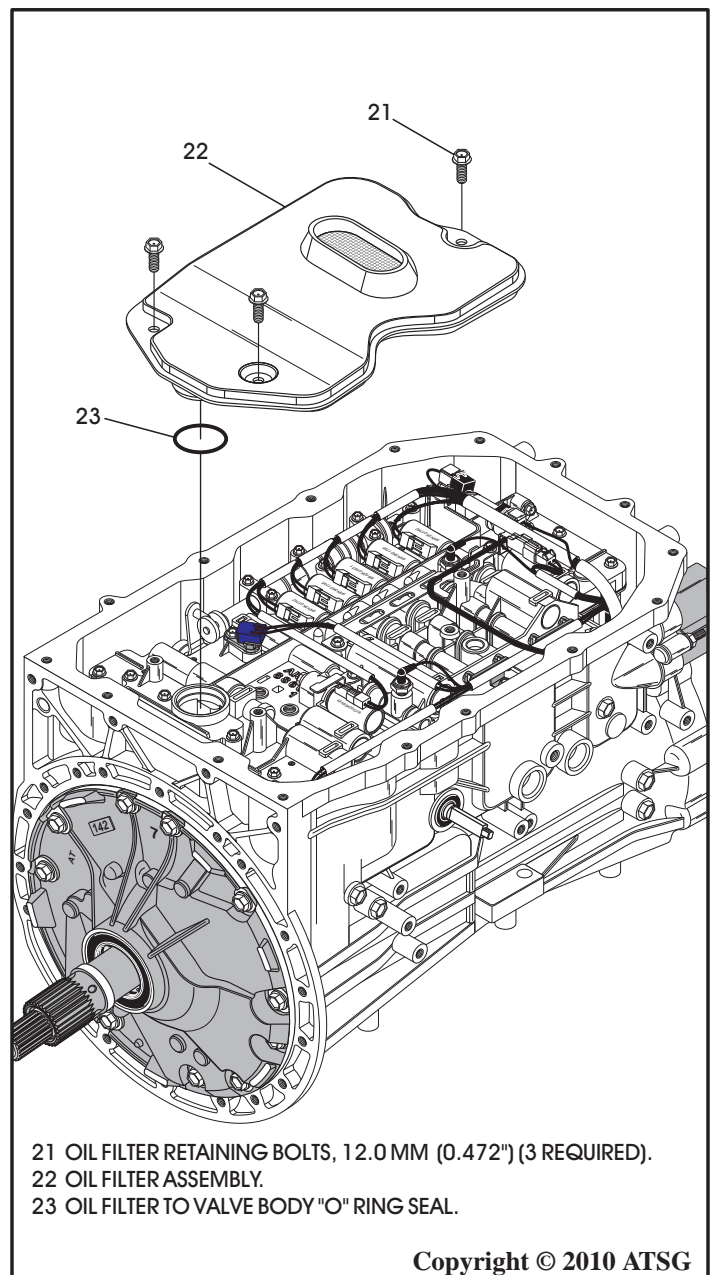

Figure 46

TRANSMISSION DISASSEMBLY (CONT'D)

18. Remove the TFT sensor retaining bracket bolt and remove the sensor from valve body bore, as shown in Figure 47.
Note: Before removing any solenoid connectors log the colors of the wires to each solenoid to avoid any mis-assembly concerns.
19. Disconnect all solenoid connectors, both switch connectors (if used) and White OSS connector, as shown in Figure 47.
20. Disconnect Yellow connector from ISS located on the oil pump, as shown in Figure 47.
Note: Follow the Red and White wires down to the connector.
21. Remove the pass-thru case connector retaining bolt, as shown in Figure 48.
22. Remove both pass-thru case connector and wire harness assemblies, as shown in Figure 48, and remove and discard the 3 "O" ring seals.

Continued on Page 37

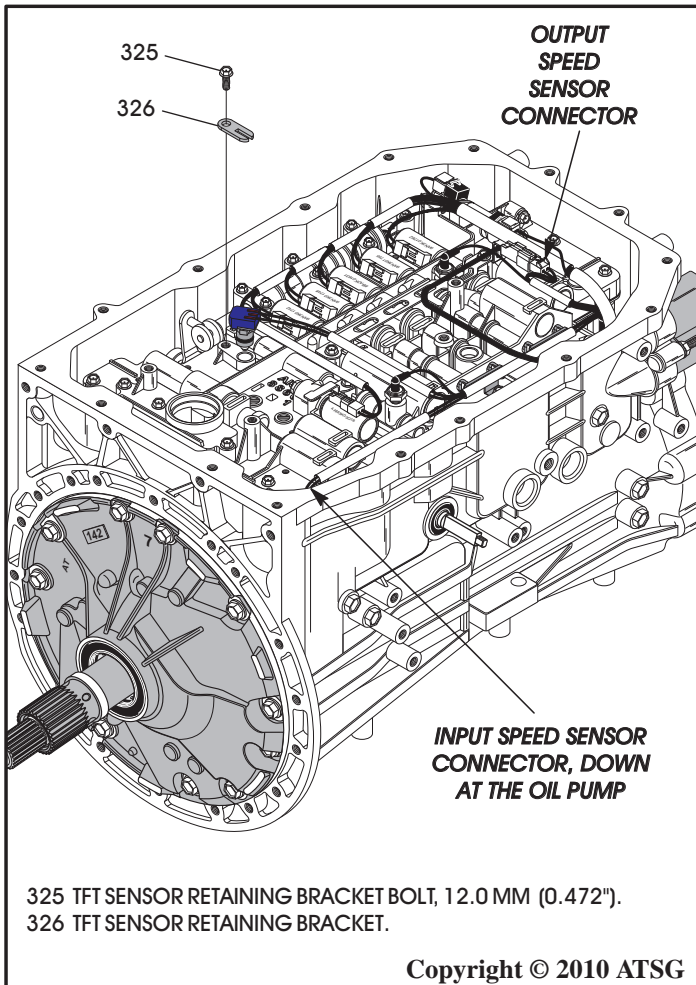

Figure 47

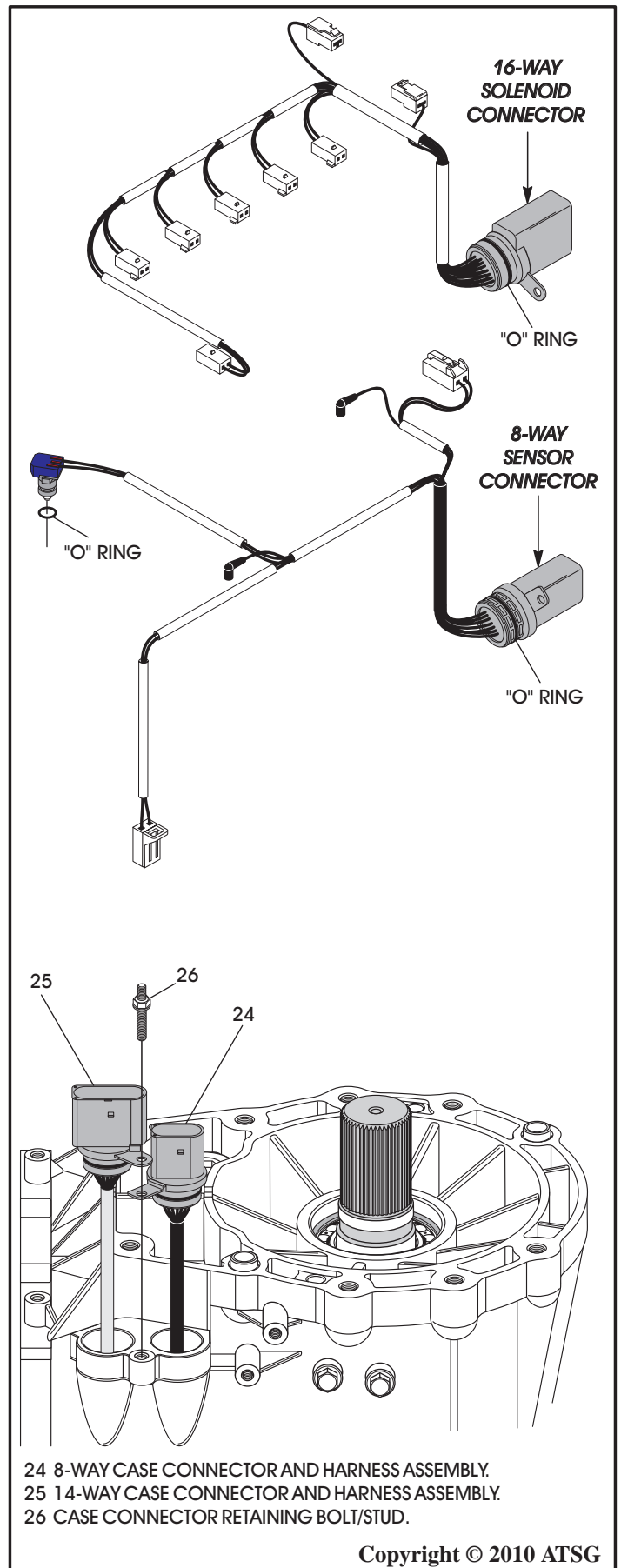

Figure 48

TRANSMISSION DISASSEMBLY (CONT'D)

23. Remove the White OSS harness connector from the solenoid pin retaining bracket, as shown in Figure 49, using a pick.
24. Lay the OSS harness and white connector over the pan rail, as shown in Figure 49.
25. Remove only the 14 valve body to case retaining bolts from the locations shown in Figure 50.
Note: Notice that there are 2 different lengths of valve body retaining bolts.

Continued on Page 38

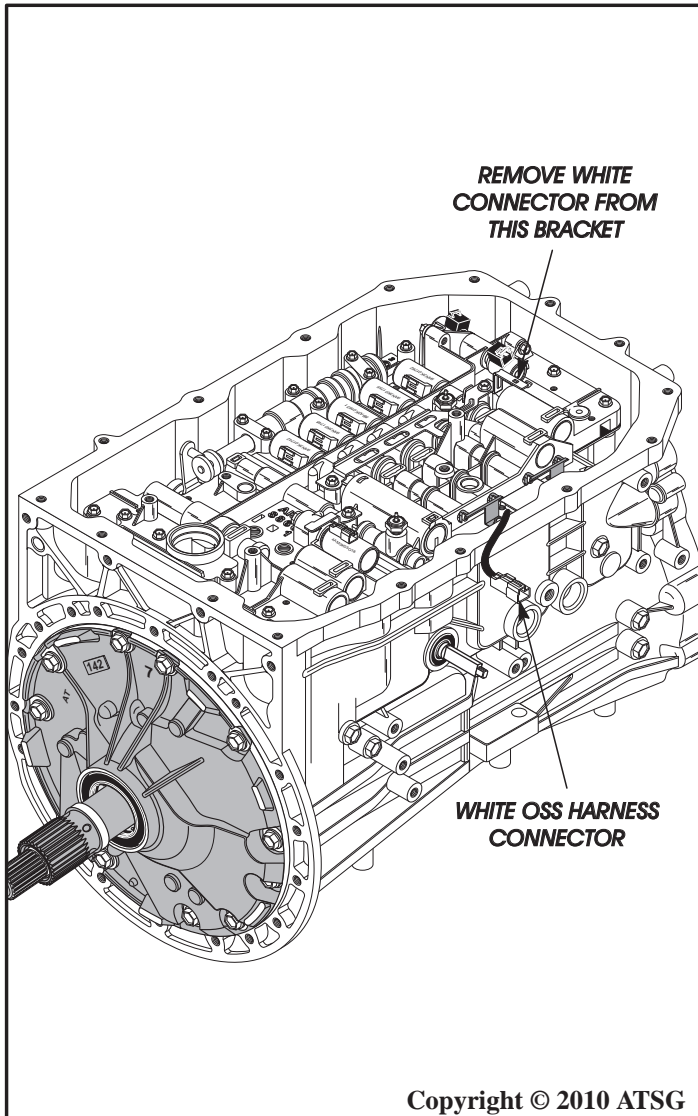

Figure 49

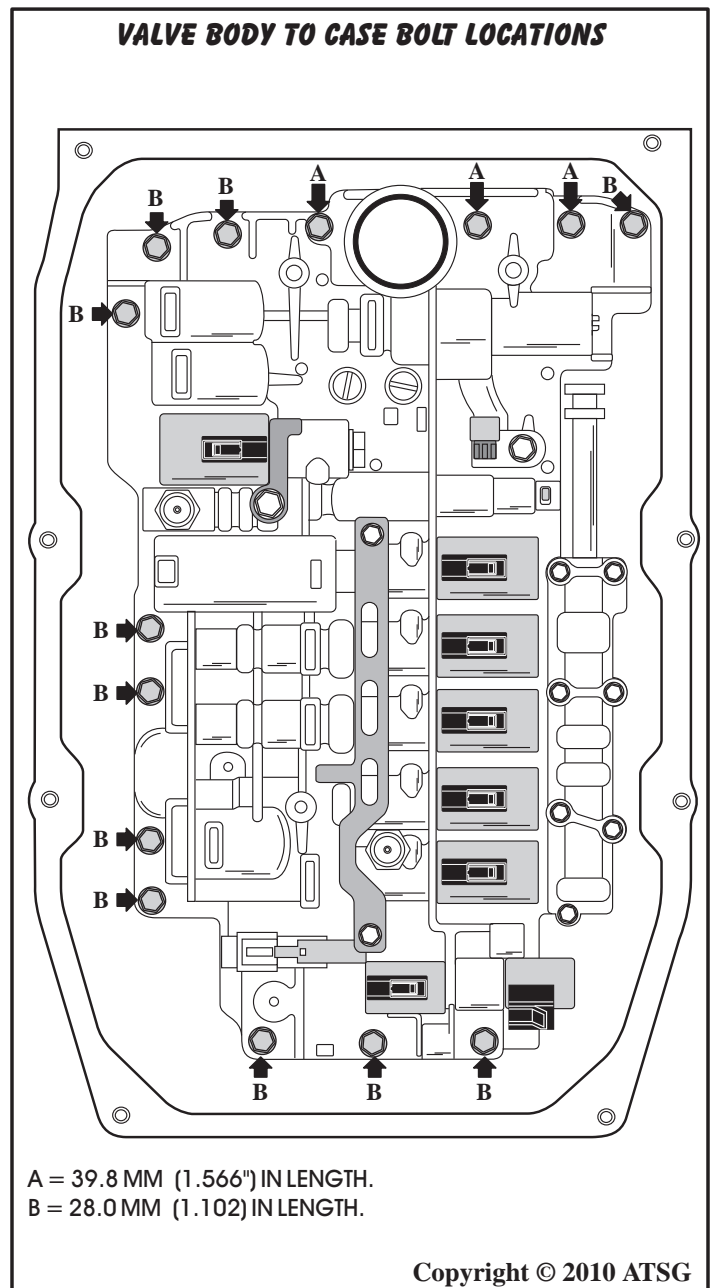

Figure 50

TRANSMISSION DISASSEMBLY (CONT'D)

26. Remove the valve body assembly, as shown in Figure 51, and set aside for component rebuild.
27. Remove the bolts from the output speed sensor and output speed sensor wire harness retainer, as shown in Figure 52.

28. Remove output speed sensor and wire harness assembly from case, as shown in Figure 52.

Continued on Page 39

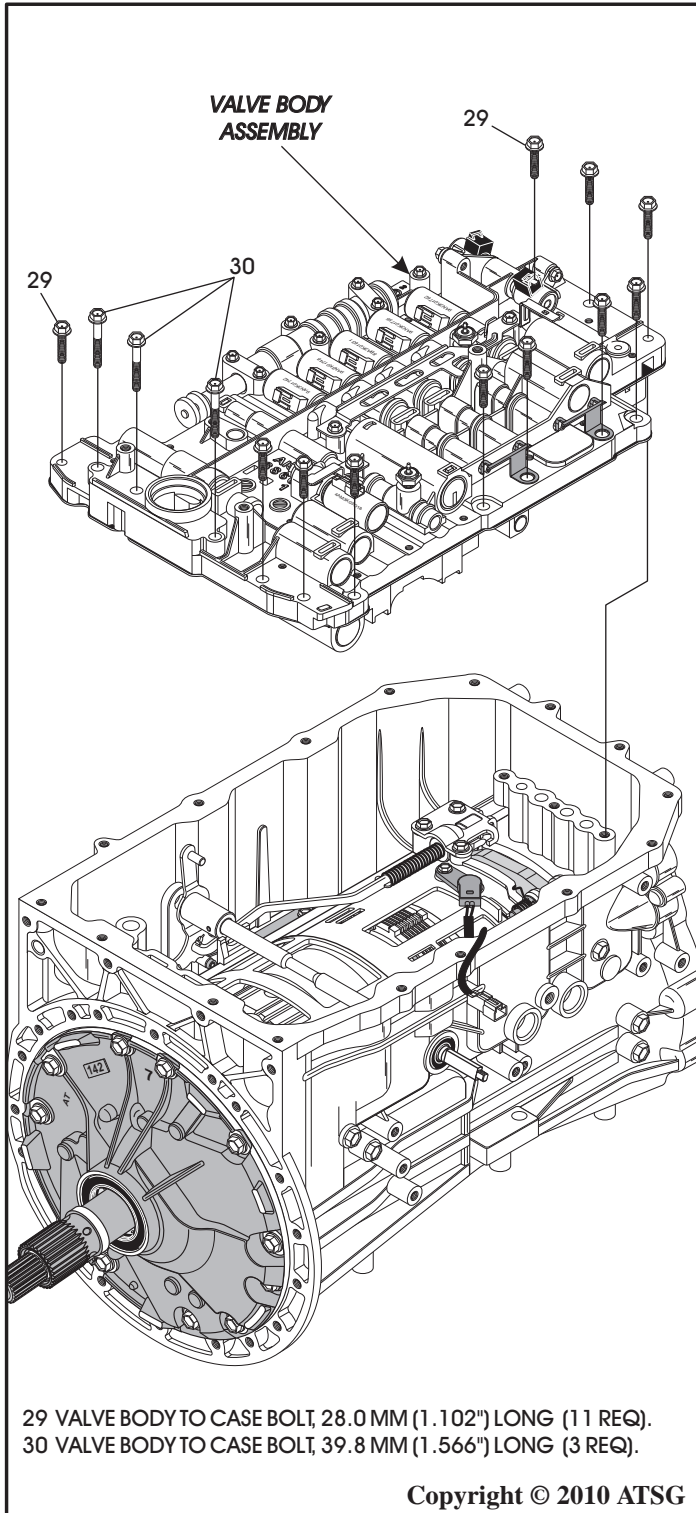

Figure 51

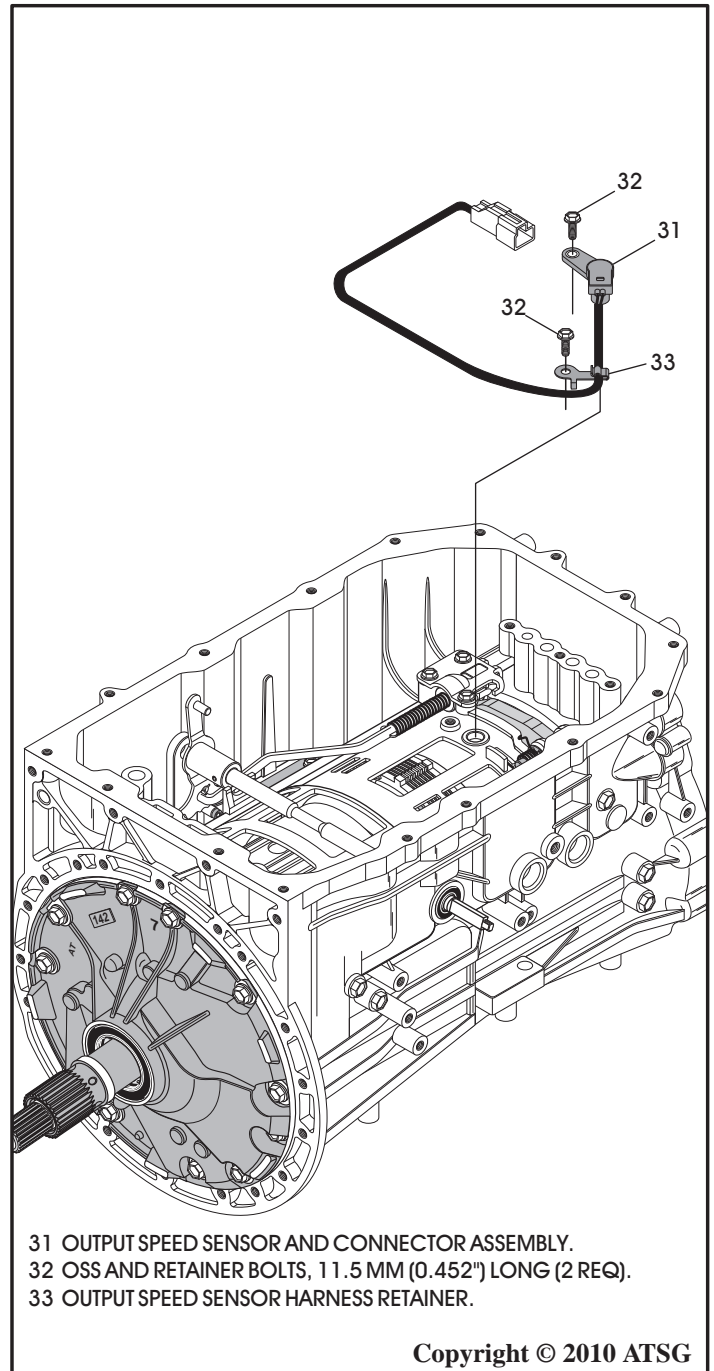

Figure 52

TRANSMISSION DISASSEMBLY (CONT'D)

29. Remove the ten oil pump retaining bolts, as shown in Figure 53.
30. Install slide hammers into oil pump in positions shown in Figure 54.
31. Using the slide hammers to loosen the oil pump and remove oil pump as shown in Figure 54.
32. Set oil pump aside for component rebuild.
33. Remove the number 1 plastic thrust washer, as shown in Figure 54.

Note: Thrust washer may be stuck to back of oil pump.

Important: If the washer did come off with the oil pump, put it back on the K3 clutch housing and measure distance from straight edge to thrust washer, as shown in Figure 54. Record this measurement to verify proper re-assembly.
34. The entire B1 clutch pack and snap ring must be removed "before" you can remove the K3 clutch housing.

Continued on Page 40

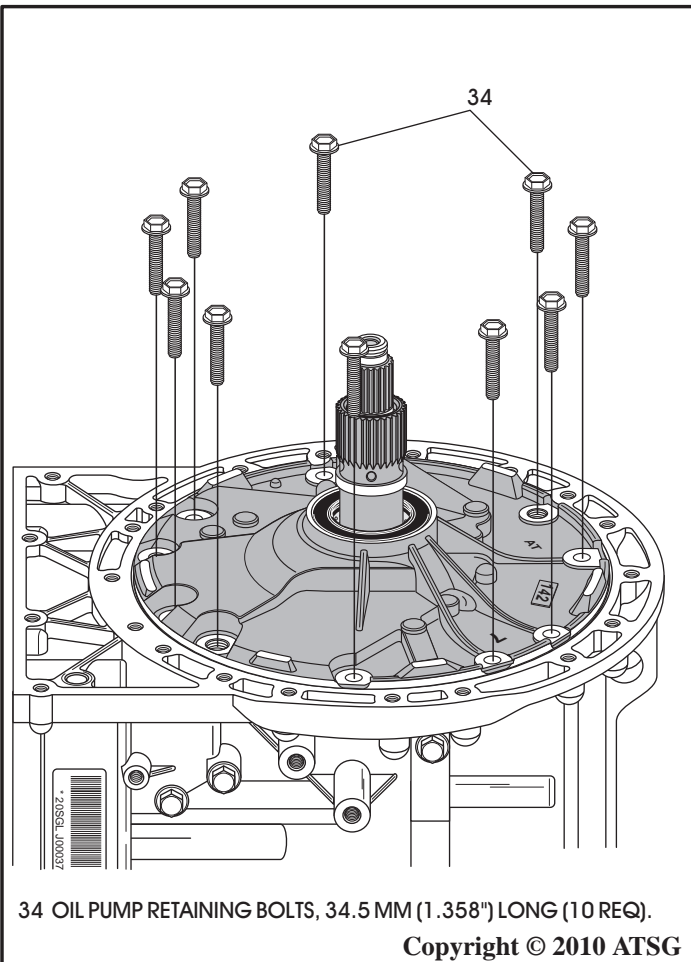

Figure 53

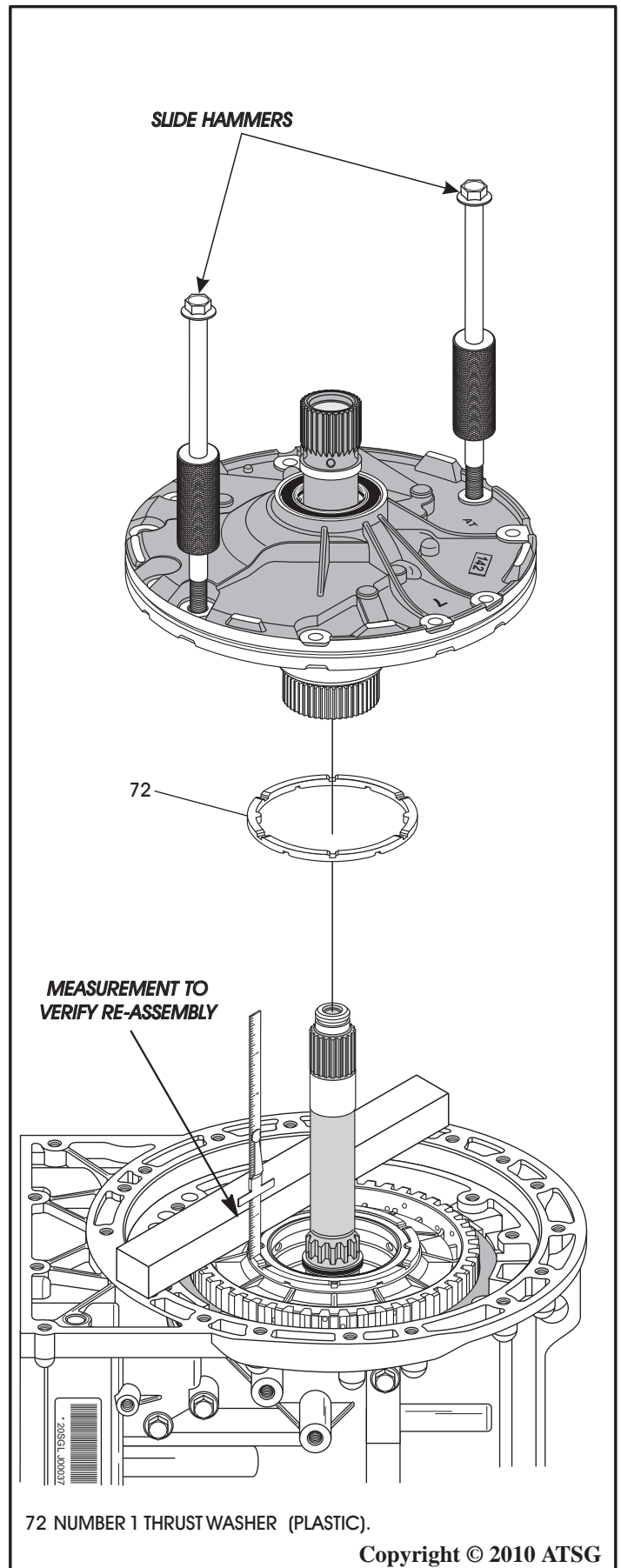

Figure 54

TRANSMISSION DISASSEMBLY (CONT'D)

35. Remove the B1 clutch cushion plate, as shown in Figure 55.
 36. Remove the B1 clutch apply plate, as shown in Figure 55.
 37. Remove the B1 clutch friction and steel plates, as shown in Figure 55.
- Note: Two picks will be handy for these steps.*
38. Remove the B1 clutch backing plate, as shown in Figure 55.
 39. Remove the B1 clutch backing plate snap ring from case, as shown in Figure 56.

Continued on Page 41

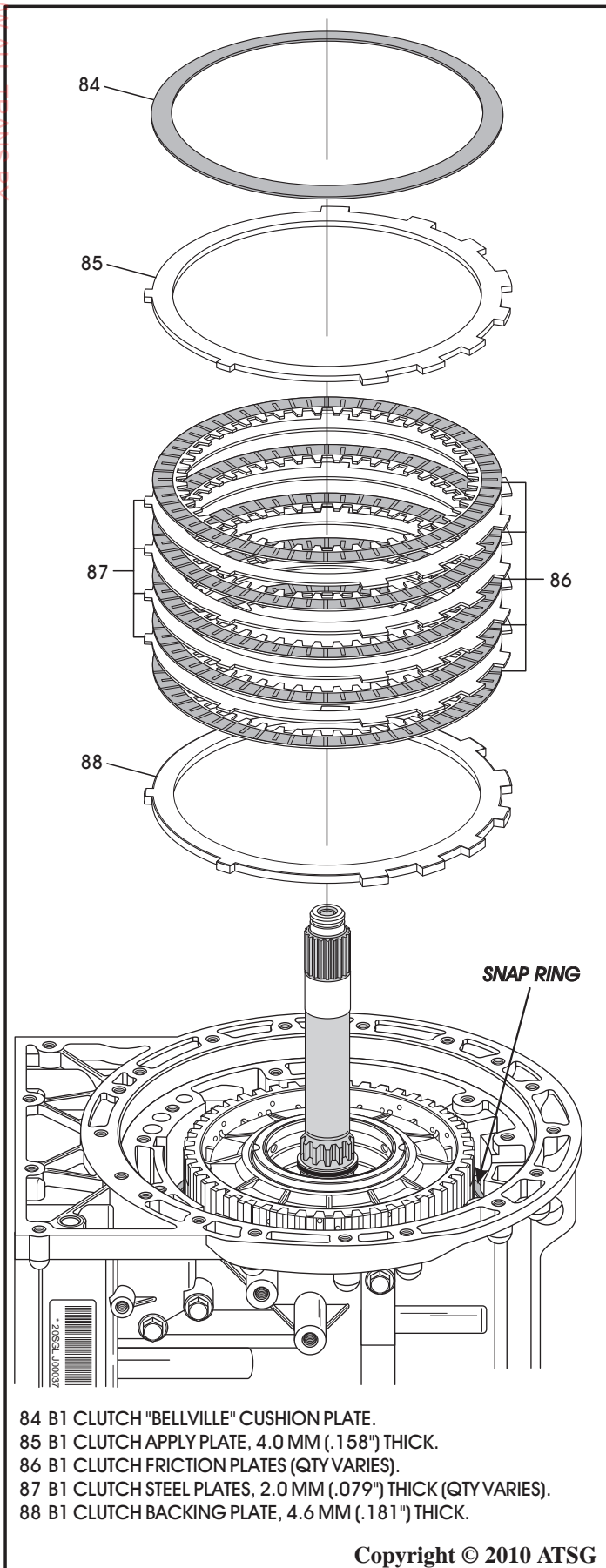

Figure 55

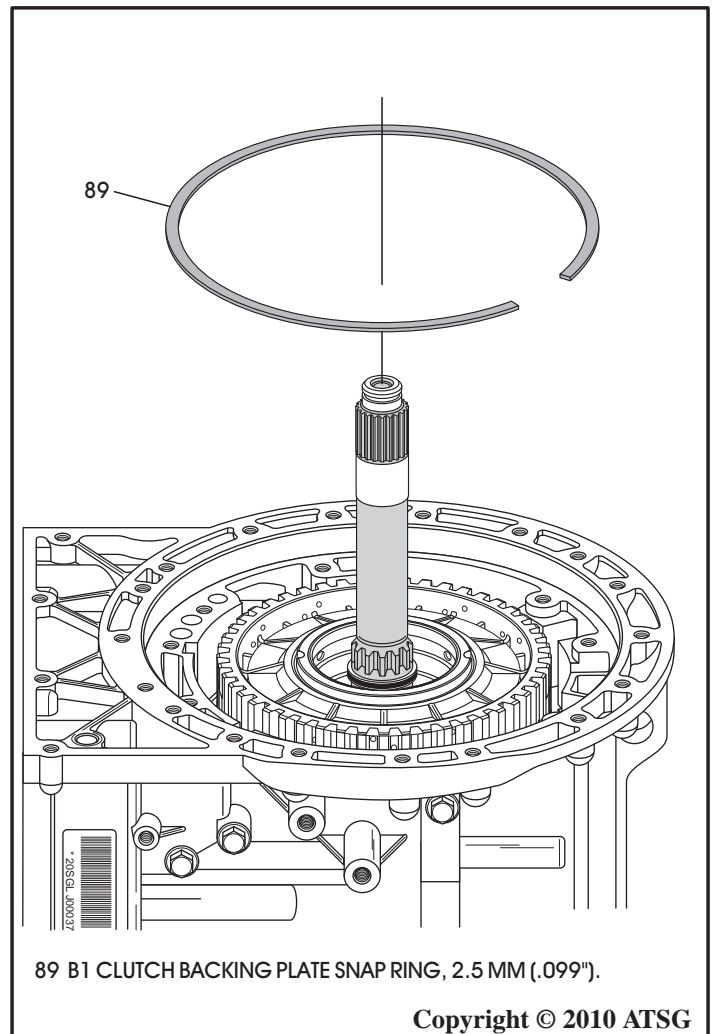

Figure 56

TRANSMISSION DISASSEMBLY (CONT'D)

40. Now, you can remove the K3 clutch housing, as shown in Figure 57.
Note: Do not lose the number 2 thrust washer hardened race (See Figure 57), may be stuck to K3 balance piston.

41. Remove the number 1 plastic thrust washer from K3 clutch housing and set K3 housing aside for component rebuild.
Note: Number 1 thrust washer may have been stuck to oil pump.
42. Remove turbine shaft and the complete front planetary system as an assembly, as shown in Figure 58.

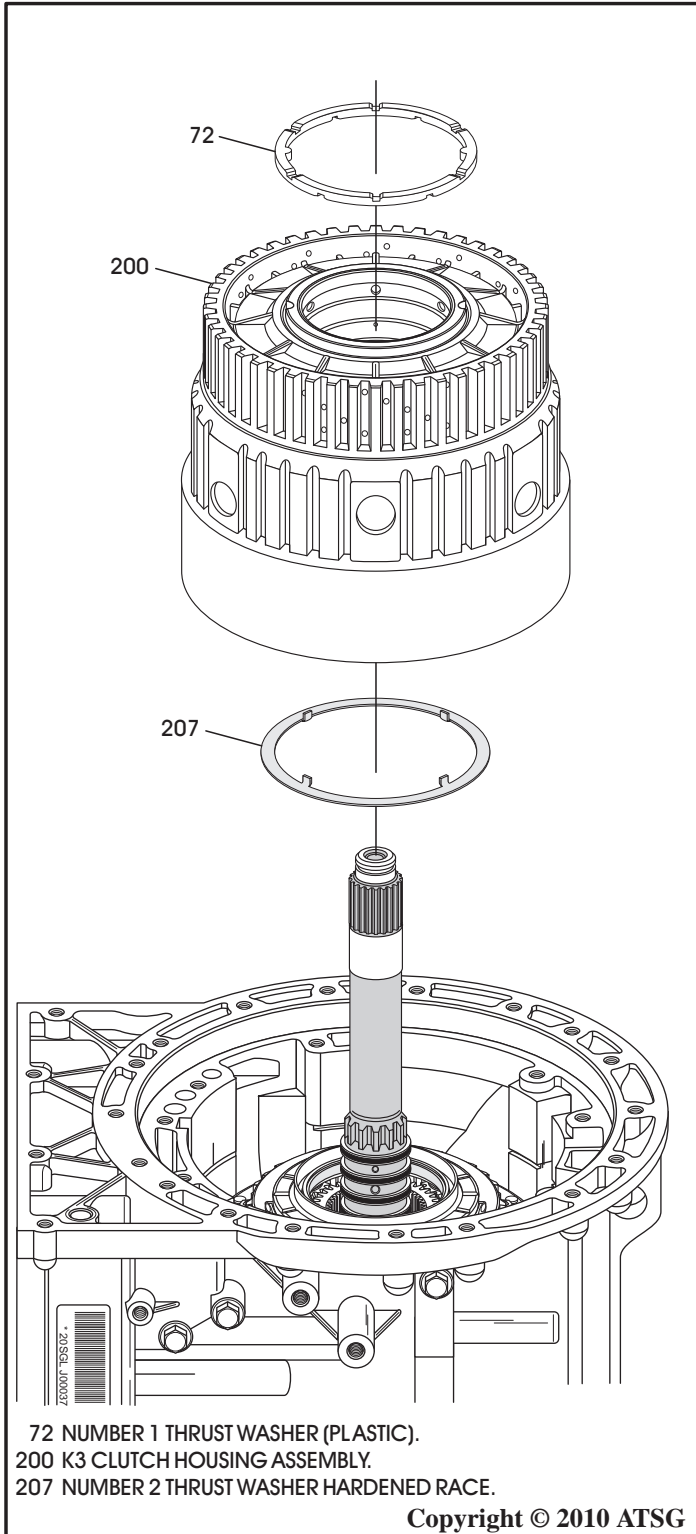

Figure 57

Continued on Page 42

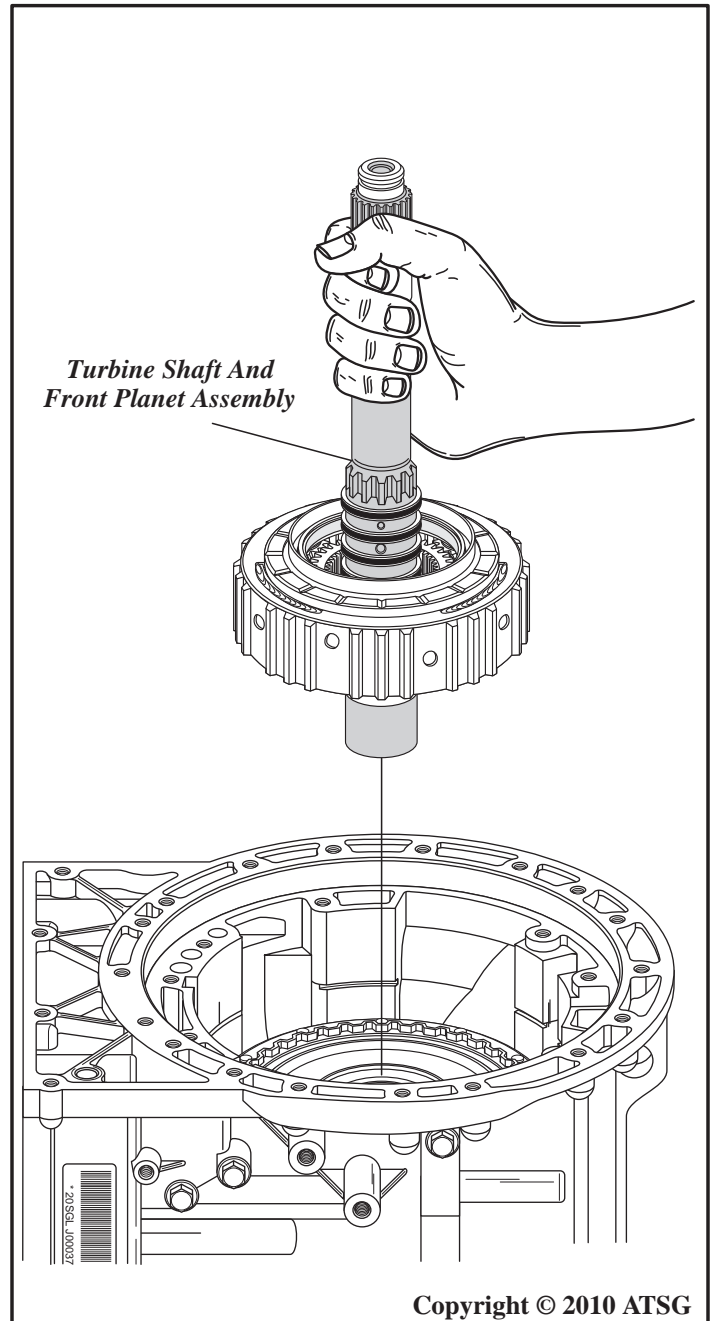
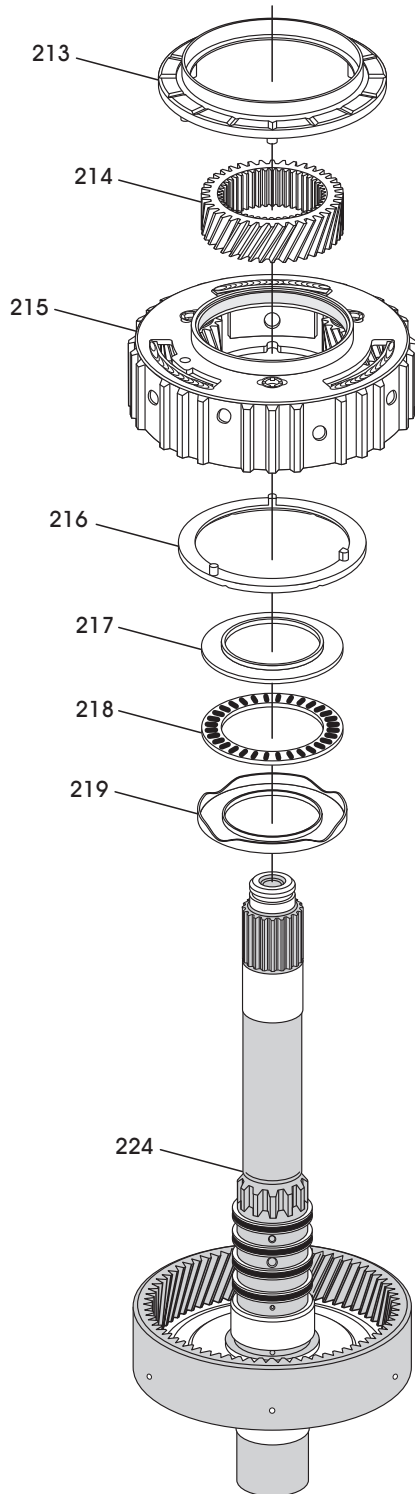

Figure 58

TRANSMISSION DISASSEMBLY (CONT'D)

43. Separate the front planetary components, as shown in Figure 59, and set aside for component rebuild section.
44. Remove the K1 clutch housing and the number 6 thrust bearing and race, as shown in Figure 60. *Note: Number 6 thrust bearing may be stuck to bottom of ring gear on turbine shaft.*
45. Set the K1 clutch housing aside for component rebuild section.

Continued on Page 43



- 213 NUMBER 3 THRUST WASHER (PLASTIC).
- 214 FRONT PLANETARY SUN GEAR.
- 215 FRONT PLANETARY CARRIER ASSEMBLY.
- 216 NUMBER 4 THRUST WASHER (PLASTIC).
- 217 NUMBER 5 THRUST BEARING FRONT RACE.
- 218 NUMBER 5 THRUST BEARING.
- 219 NUMBER 5 THRUST BEARING REAR RACE.
- 224 TURBINE SHAFT & FRONT PLANETARY RING GEAR ASSEMBLY.

Copyright © 2010 ATSG

Figure 59

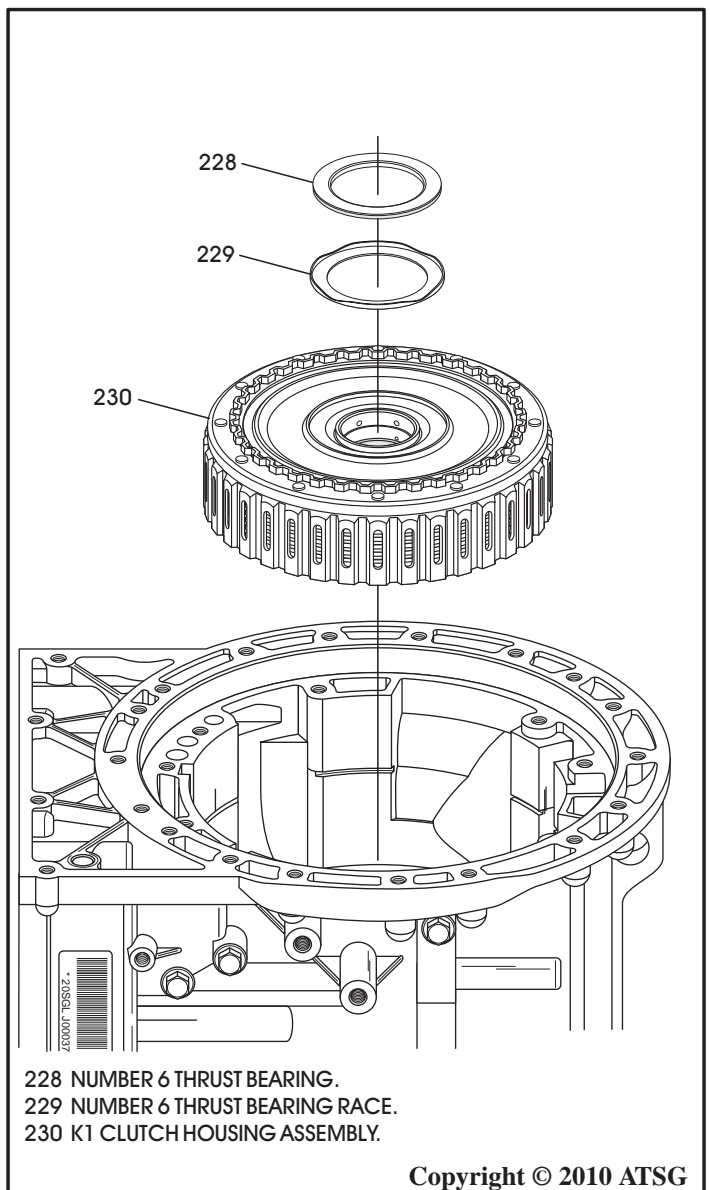

- 228 NUMBER 6 THRUST BEARING.
- 229 NUMBER 6 THRUST BEARING RACE.
- 230 K1 CLUTCH HOUSING ASSEMBLY.

Copyright © 2010 ATSG

Figure 60

TRANSMISSION DISASSEMBLY (CONT'D)

46. Remove the K1 clutch hub and the number 7 thrust bearing and race, as shown in Figure 61.
Note: Number 7 thrust bearing may be stuck to bottom of K1 clutch housing.
47. Remove the number 8 thrust bearing and race, as shown in Figure 61.
Note: Number 8 thrust bearing race may be stuck to bottom of K1 clutch hub.

48. Remove large rear sun gear and shell assembly, as shown in Figure 62.
49. Remove the number 9 thrust bearing and thrust thrust bearing race, as shown in Figure 62.
Note: Number 9 thrust bearing may be stuck to bottom of large rear sun gear.

Continued on Page 44

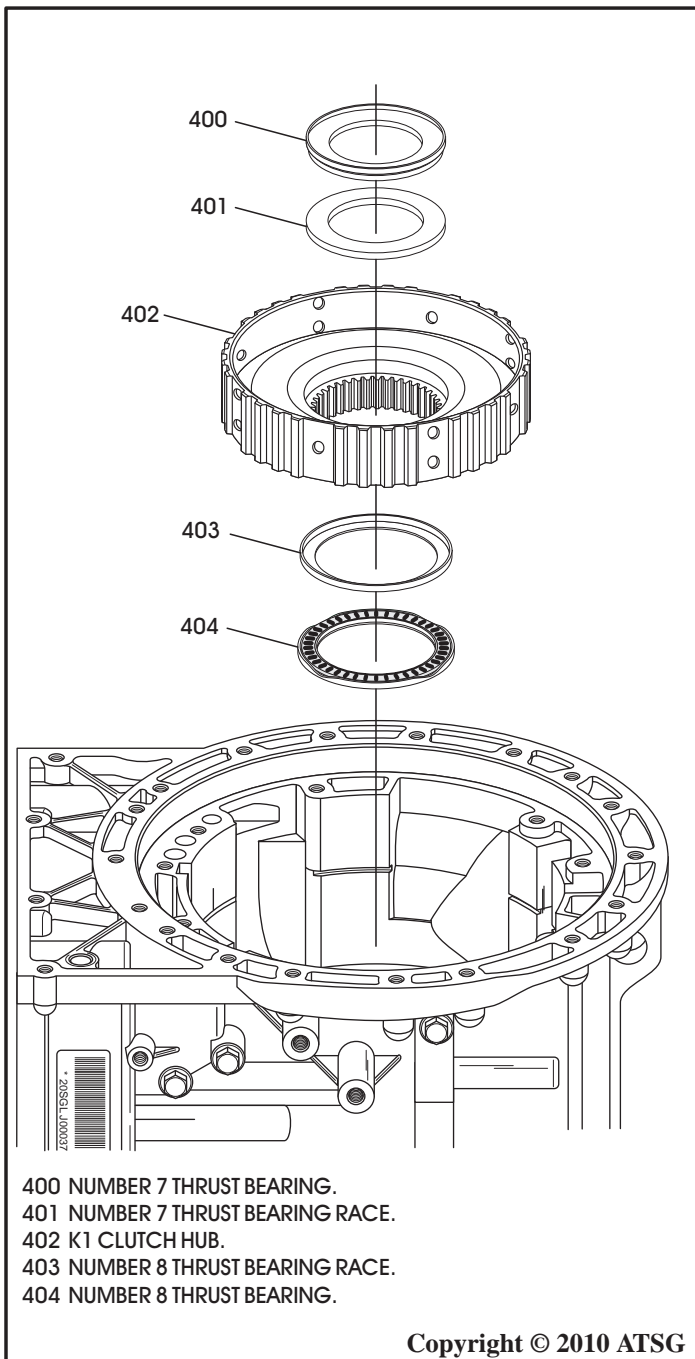

Figure 61

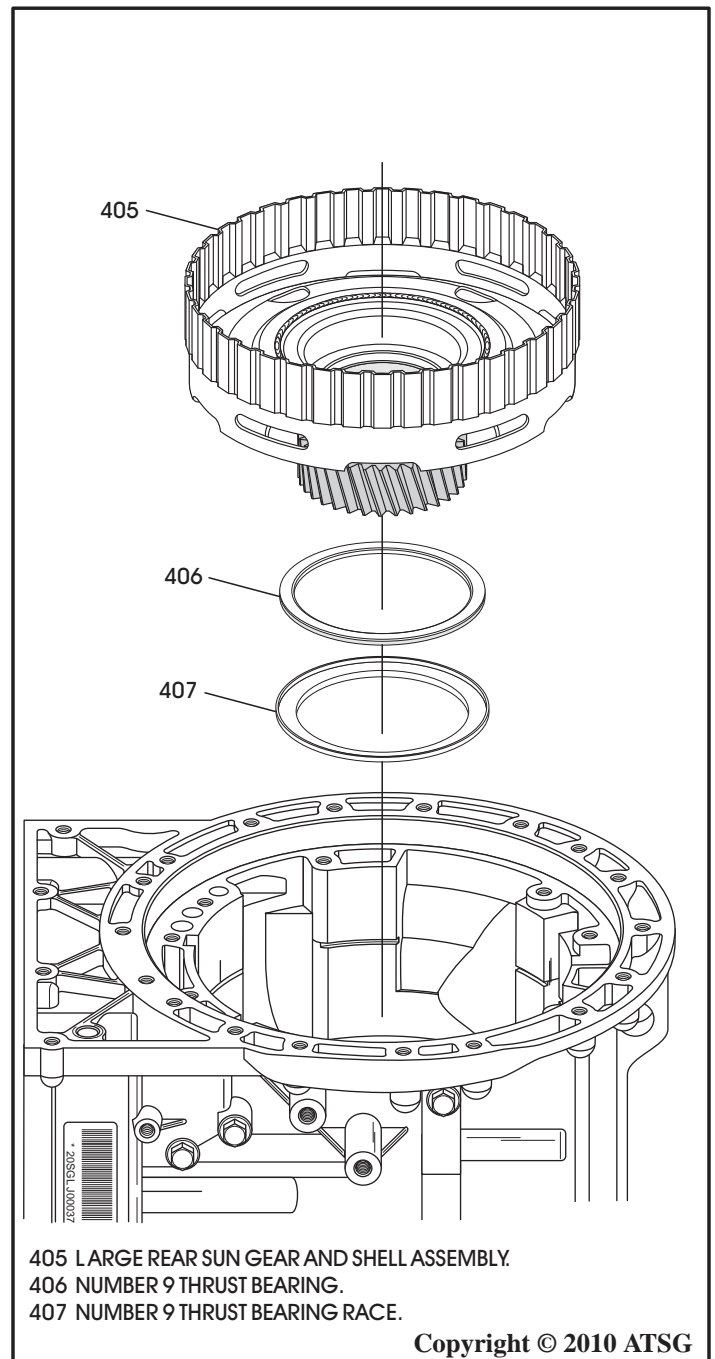

Figure 62

TRANSMISSION DISASSEMBLY (CONT'D)

50. Remove small rear sun gear and shaft assembly, as shown in Figure 63.
51. Remove the number 10 thrust bearing and race, as shown in Figure 63.
Note: Number 10 thrust bearing race may be stuck to bottom of sun gear and the number 10 bearing may remain in rear planetary carrier.
52. Remove the F1 sprag outer race snap ring from the transmission case, as shown in Figure 64.
53. Remove the F1 sprag inner race snap ring from the rear planetary carrier splines, as shown in Figure 64, using snap ring pliers.

54. Remove the F1 sprag assembly from the case, as shown in Figure 64.
Note: Picks will once again be handy for sprag removal.
55. Set the F1 sprag assembly aside for component rebuild section.

Continued on Page 45

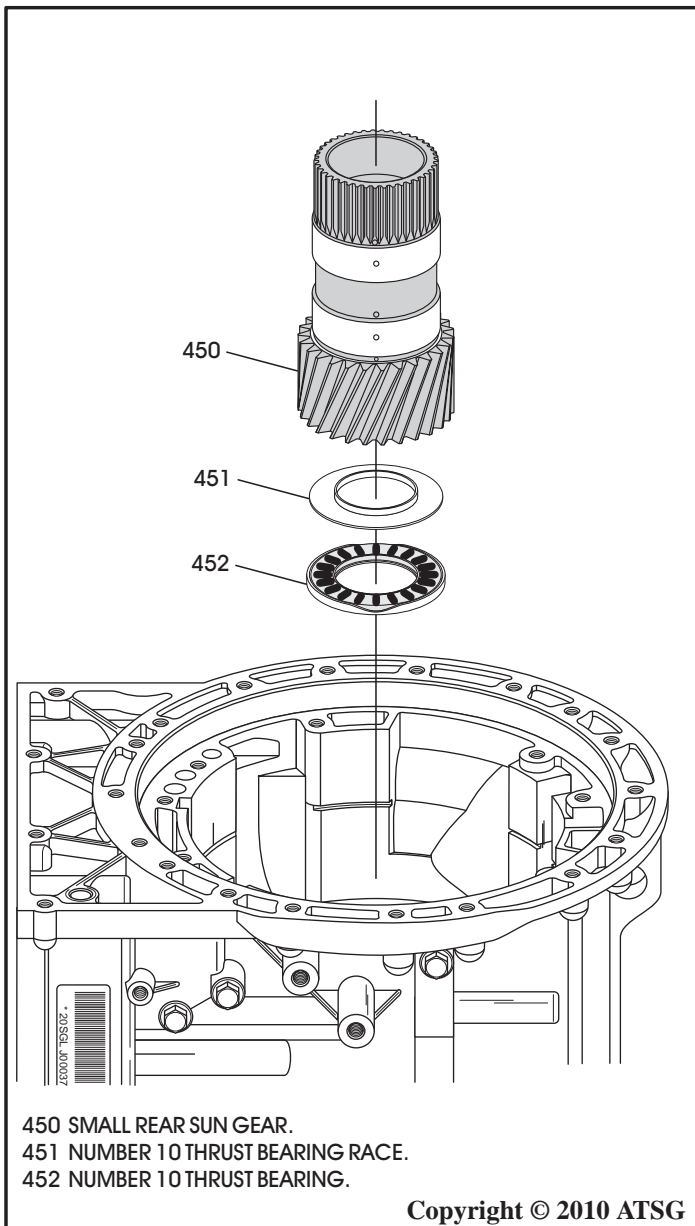

Figure 63

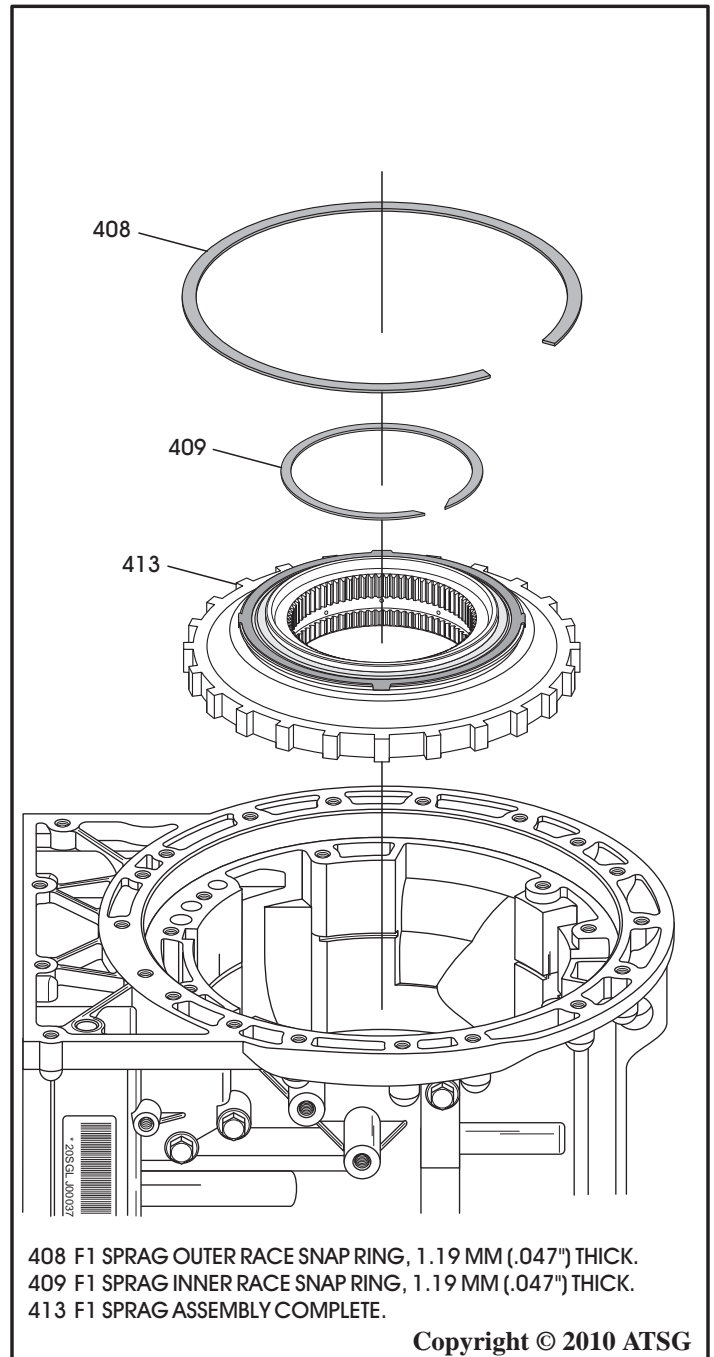

Figure 64

TRANSMISSION DISASSEMBLY (CONT'D)

56. Remove the B2 clutch backing plate snap ring, as shown in Figure 65.
57. Remove the B2 clutch backing plate, as shown in Figure 65.
58. Remove the B2 clutch friction and steel plates, as shown in Figure 65.
59. Remove the B2 clutch apply plate, as shown in Figure 65.
60. Remove the rear planetary carrier assembly, as shown in Figure 66.

Continued on Page 46

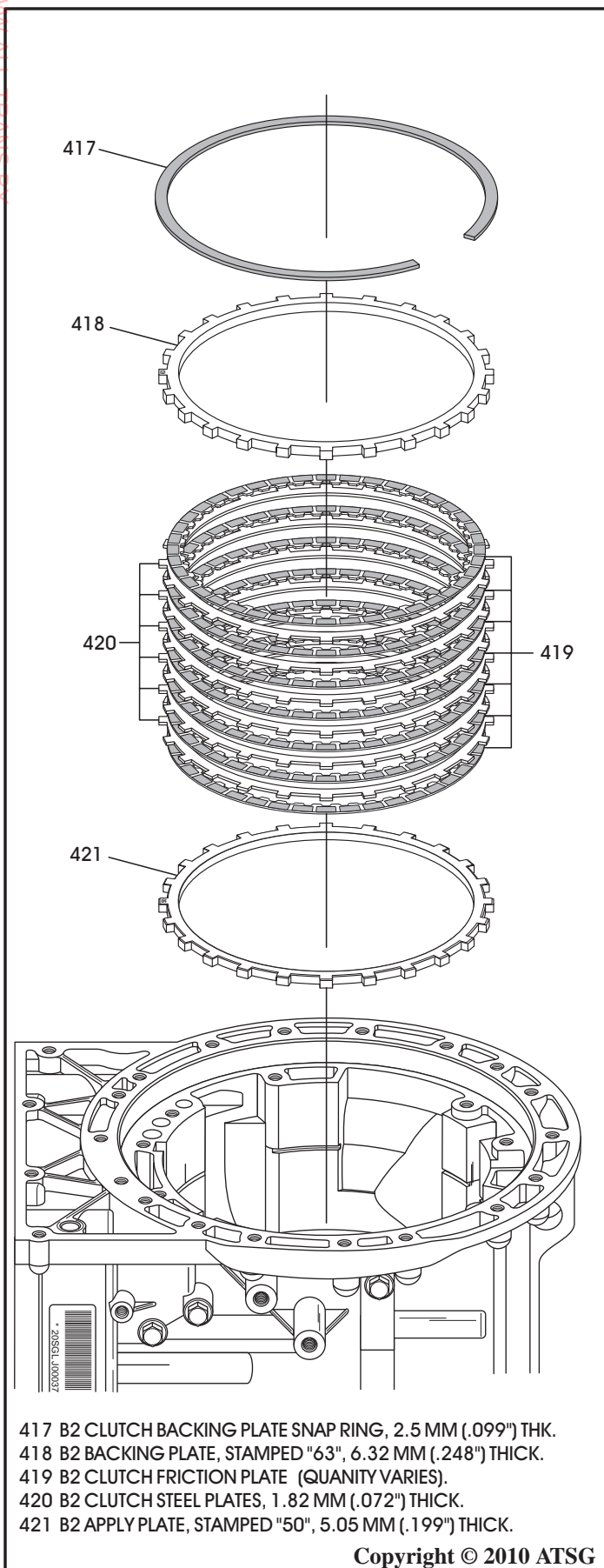

Figure 65

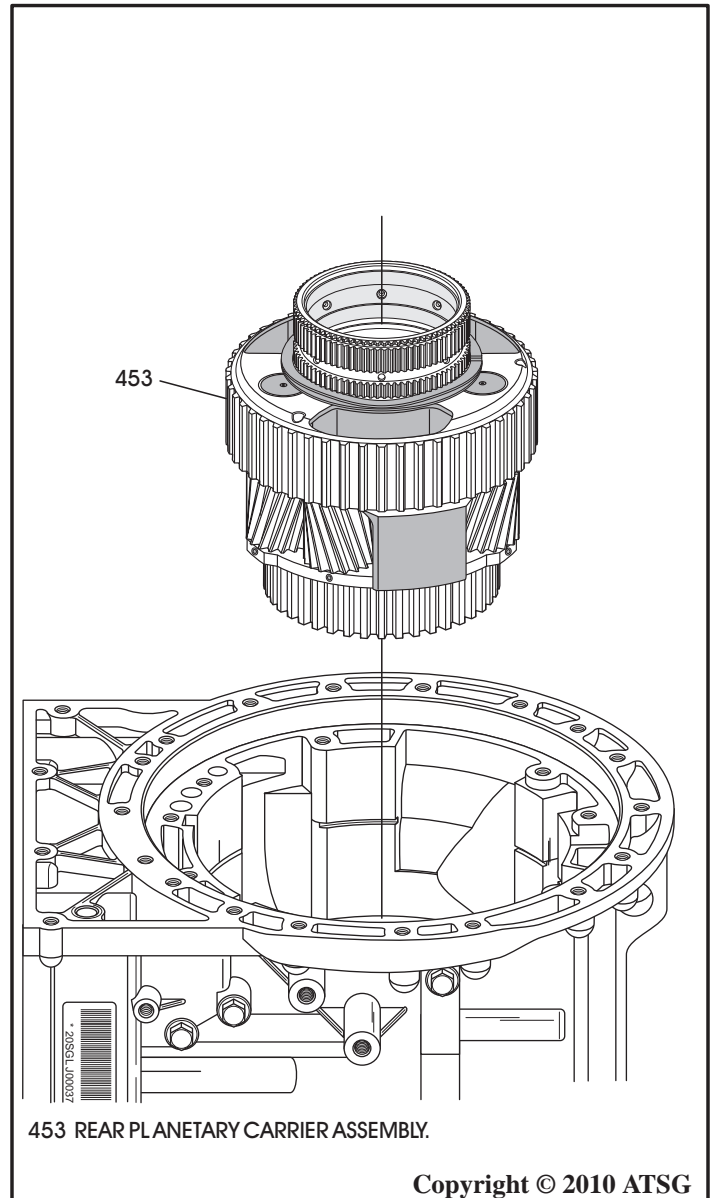

Figure 66

TRANSMISSION DISASSEMBLY (CONT'D)

61. Separate rear planetary carrier parts, as shown in Figure 67.

Note: Number 10 thrust bearing race may be stuck to back side of small rear sun gear.

62. Remove rear planetary ring gear, output shaft and K2 clutch housing as an assembly, as shown in Figure 68, and set aside for the component rebuild section.

Note: Number 11 front thrust bearing race may be stuck to back side of the rear planetary carrier.

Continued on Page 47

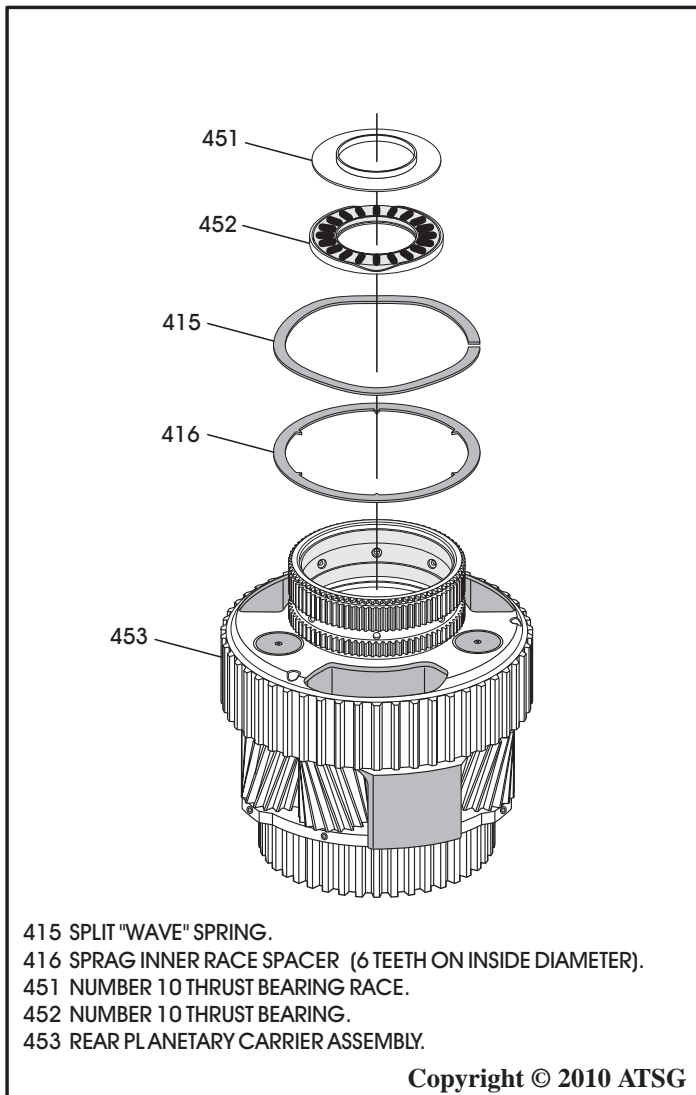

Figure 67

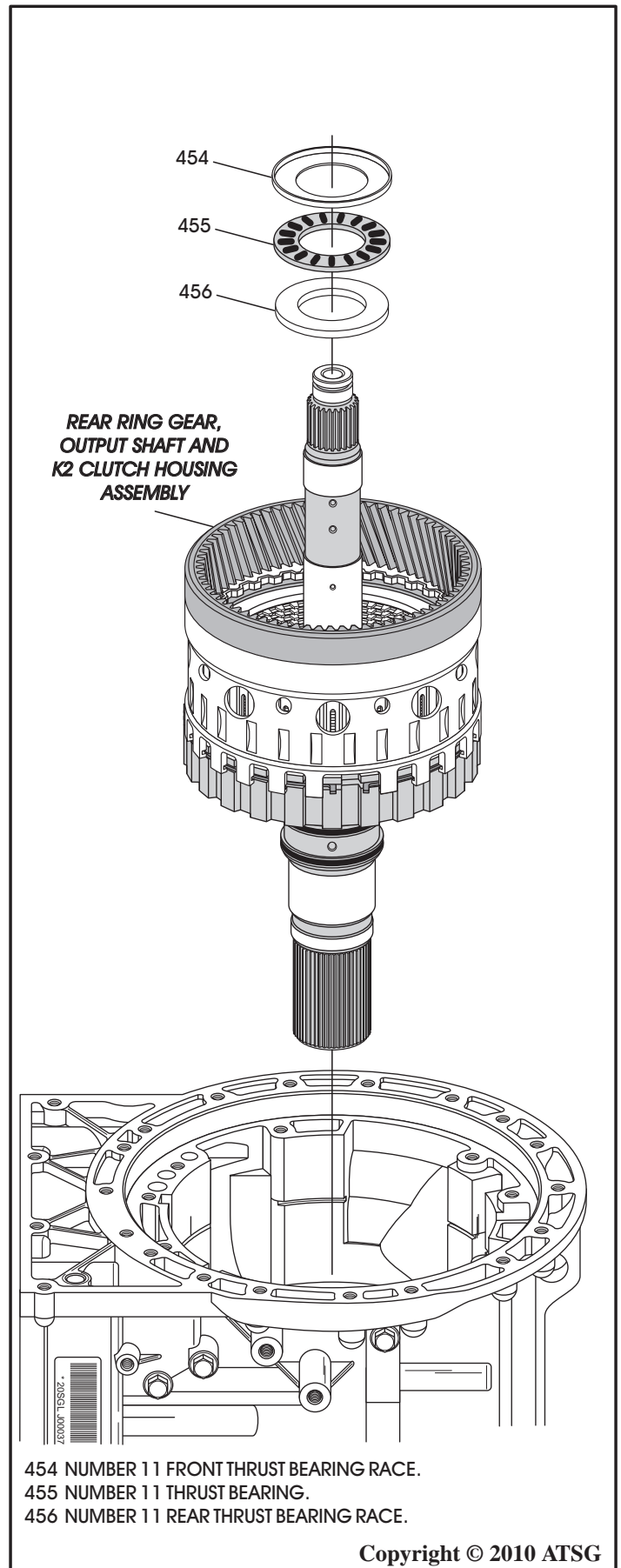

Figure 68

TRANSMISSION DISASSEMBLY (CONT'D)

The output shaft, the rear planetary ring gear and the K2 clutch housing are removed as an assembly and installed as an assembly. The K2 clutch housing cannot be removed without separating the rear planetary ring gear from the output shaft. They are connected with an internal snap ring in the output shaft that locks into an internal groove in the rear planetary ring gear.

63. Squeeze the internal snap ring together using a pair of needle nose pliers, as shown in Figure 69, to release the rear planetary ring gear.

Note: An assistant may have to tap on the ring gear to move it off the snap ring.

64. Separate the output shaft, rear planetary ring gear and K2 clutch housing, as shown in Figure 70, and set aside for the component rebuild process.

Note: The number 12 thrust bearing front race may be stuck to the back of K2 clutch housing.

Continued on Page 48

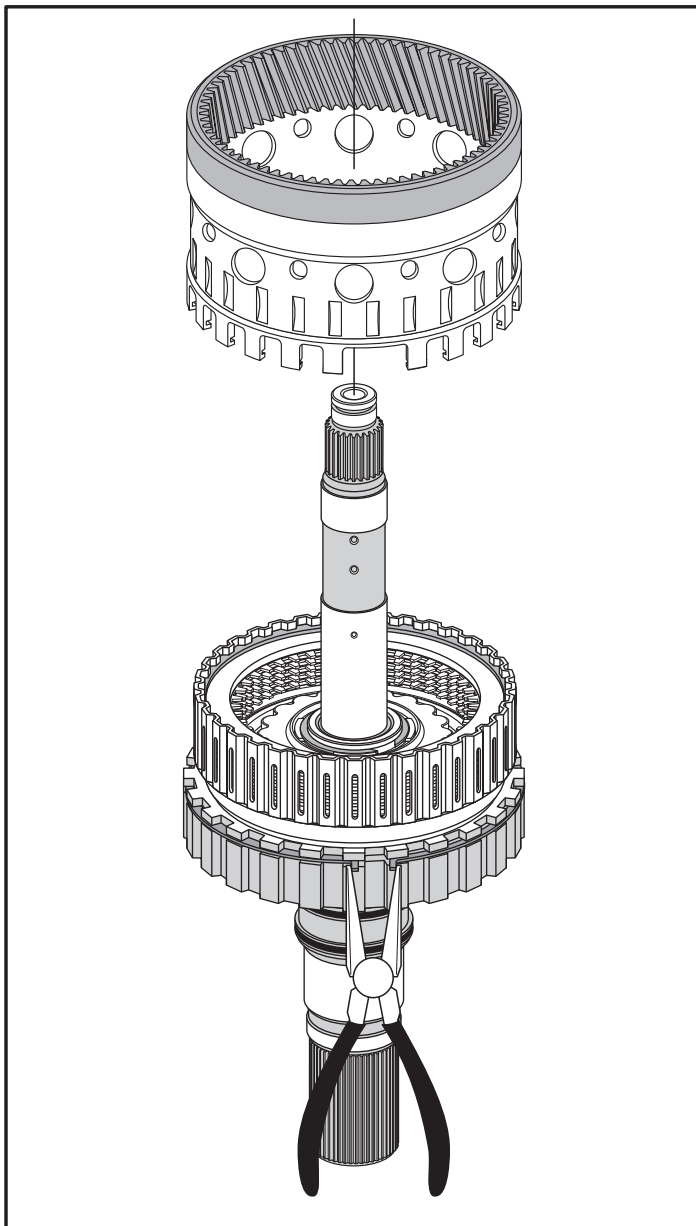
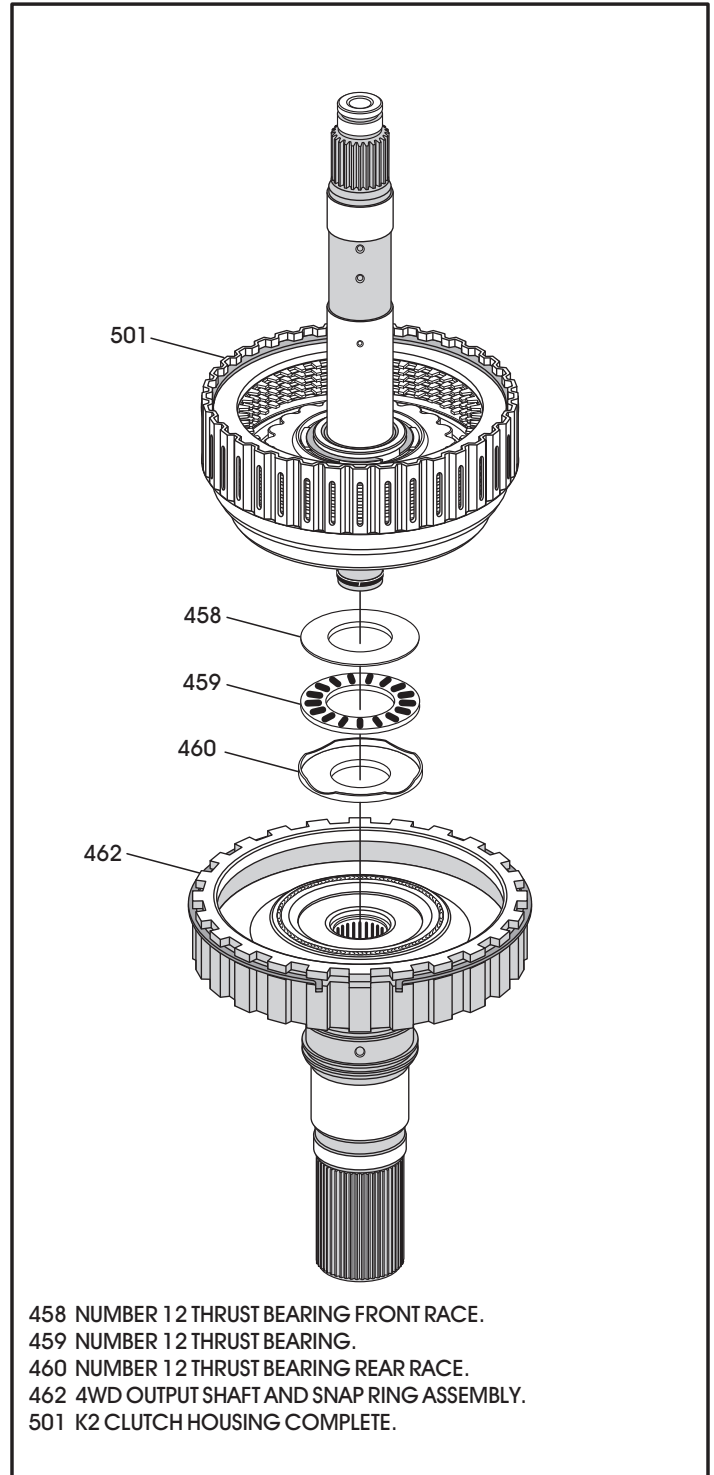

Figure 69



- 458 NUMBER 12 THRUST BEARING FRONT RACE.
- 459 NUMBER 12 THRUST BEARING.
- 460 NUMBER 12 THRUST BEARING REAR RACE.
- 462 4WD OUTPUT SHAFT AND SNAP RING ASSEMBLY.
- 501 K2 CLUTCH HOUSING COMPLETE.

Figure 70

TRANSMISSION DISASSEMBLY (CONT'D)

65. Remove the number 13 thrust bearing and thrust bearing race, as shown in Figure 71.

Note: Number 13 thrust bearing may be stuck to back side of the output shaft.

66. Compress the B2 clutch piston return spring assembly and remove the snap ring.

Note: This is a deep case and the compressor from "Adapt-A-Case", shown in Figure 72, gave great access to the snap ring and worked very well.

67. Remove snap ring and return spring assembly from the case, as shown in Figure 73.

CAUTION: The parking pawl and all linkage "must" be removed from the case "before" the B2 clutch piston can be removed, as the parking pawl passes through the piston.

Continued on Page 50

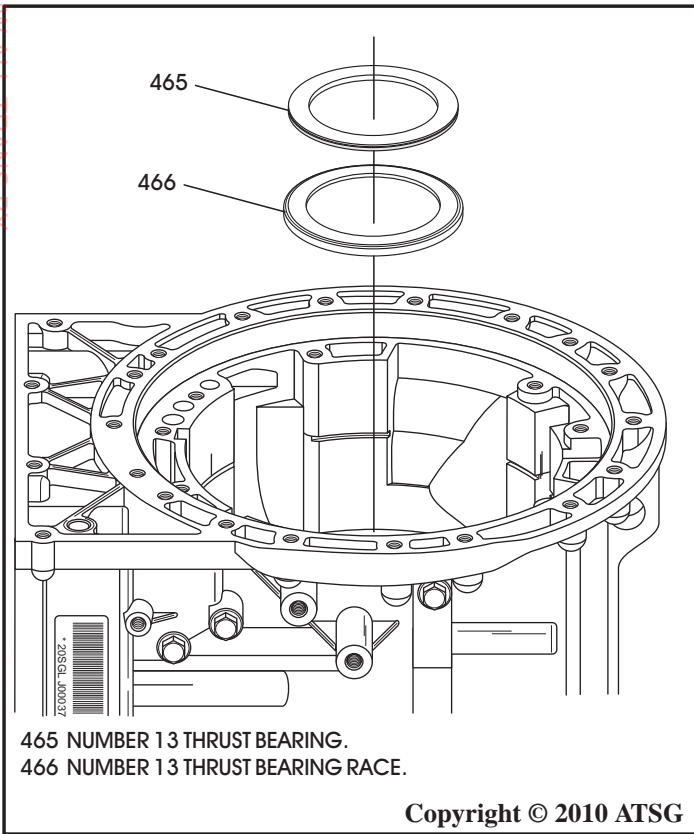

Figure 71

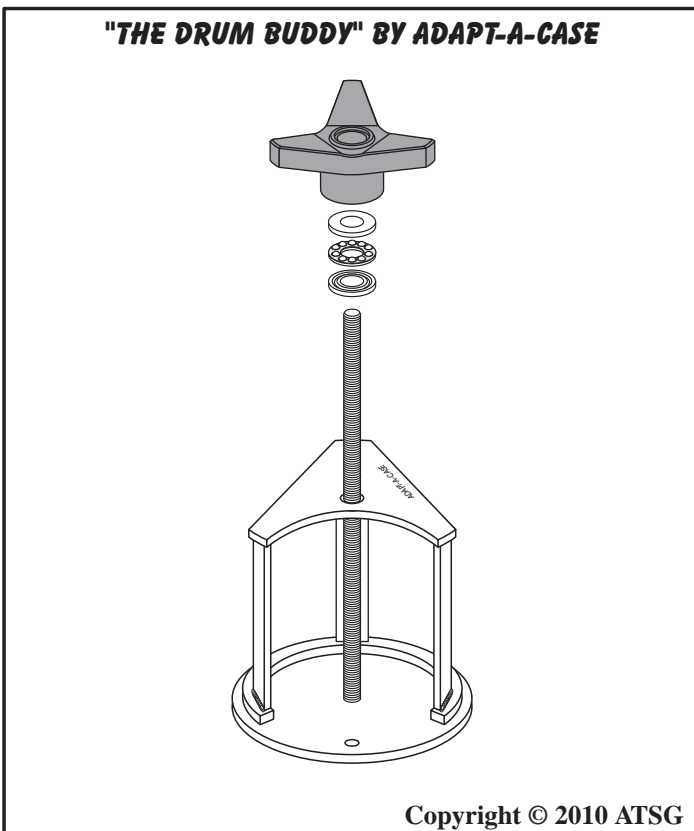

Figure 72

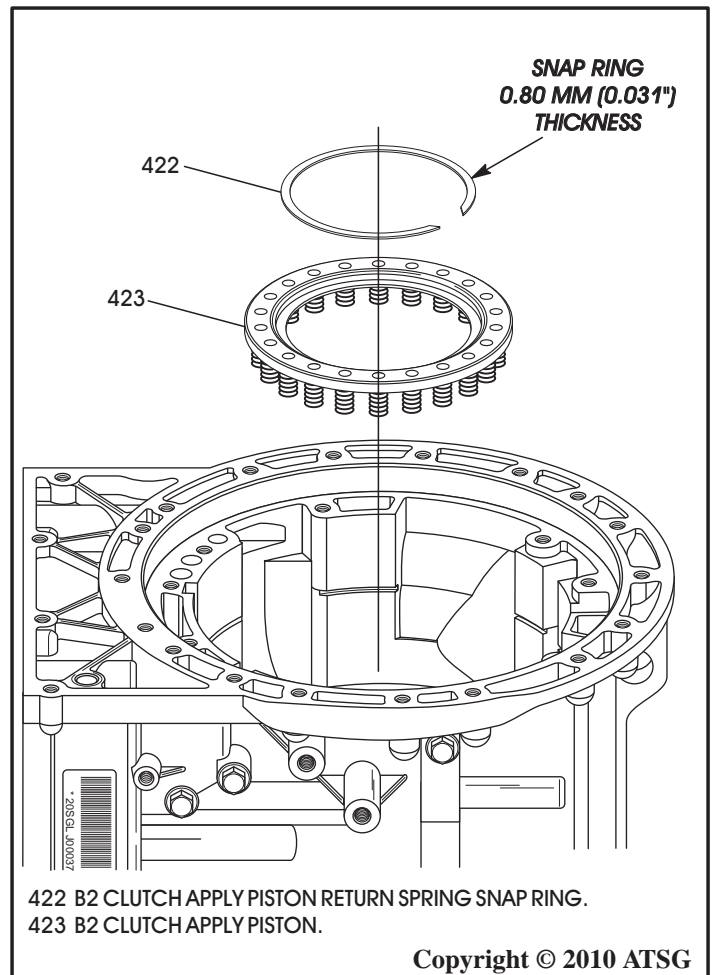
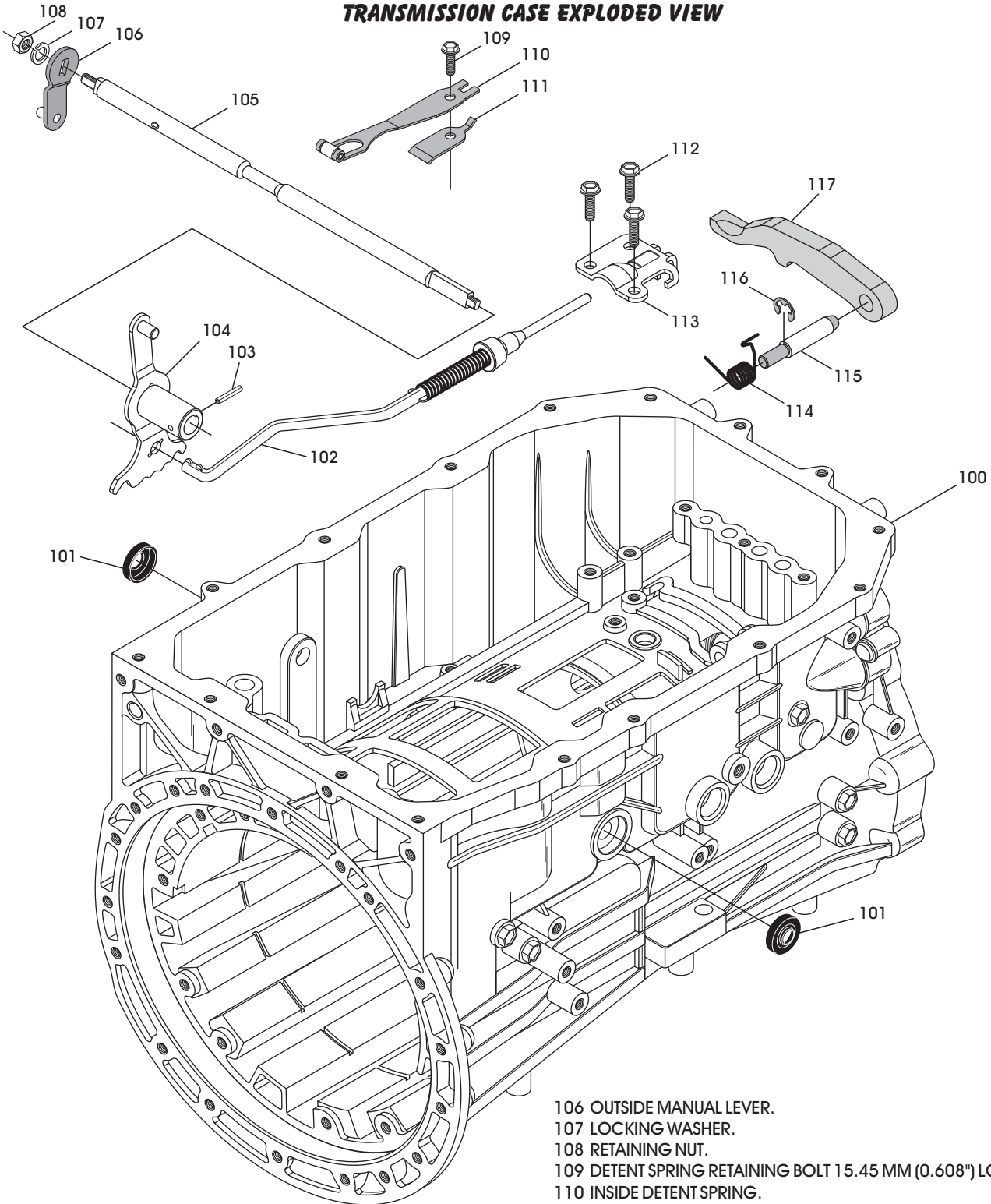

Figure 73

TRANSMISSION CASE EXPLODED VIEW



- 100 TRANSMISSION CASE ASSEMBLY.
- 101 MANUAL SHAFT SEALS (2 REQUIRED).
- 102 PARKING ROD AND ACTUATOR ASSEMBLY.
- 103 ROLLED PIN.
- 104 INSIDE DETENT LEVER.
- 105 MANUAL SHAFT.

- 106 OUTSIDE MANUAL LEVER.
- 107 LOCKING WASHER.
- 108 RETAINING NUT.
- 109 DETENT SPRING RETAINING BOLT 15.45 MM (0.608") LONG.
- 110 INSIDE DETENT SPRING.
- 111 INSIDE DETENT SPRING SPACER.
- 112 ACTUATOR GUIDE RETAINING BOLT, 18.45 MM (0.726") (3 REQ).
- 113 PARKING ROD ACTUATOR GUIDE.
- 114 PARKING PAWL RETURN SPRING.
- 115 PARKING PAWL PIVOT PIN.
- 116 PARKING PAWL PIVOT PIN "E" CLIP.
- 117 PARKING PAWL.

Figure 74

TRANSMISSION DISASSEMBLY (CONT'D)

68. Remove the "rolled" pin from the inside detent lever using a 3/16" punch and hammer.
Note: There is a safety band around the inside detent lever that must be removed first. Only way to get it off is to break it and discard it. The safety band will not be reused.
69. Remove the manual shaft from the right hand side of case, as shown in Figure 74, by sliding it out through the inside detent lever and case bore.
70. Remove the inside detent lever and park rod, as shown in Figure 74.
Note: It is not necessary to remove the inside detent spring unless damaged.
71. Remove the 3 bolts from park rod guide and remove park rod guide, as shown in Figure 74.

72. Rotate park pawl to straight up position which will relieve the return spring tension.
73. Remove the park pawl return spring, park pawl pivot pin and park pawl, as shown in Figure 74.
74. Now, you can remove the B2 clutch apply piston, as shown in Figure 75.
Note: There are two passages to the B2 clutch piston that can be charged with air to loosen the piston, as shown in Figure 76.
75. Remove and discard the manual shaft seals and notice that there is one on each side of the case.

Continued on Page 51

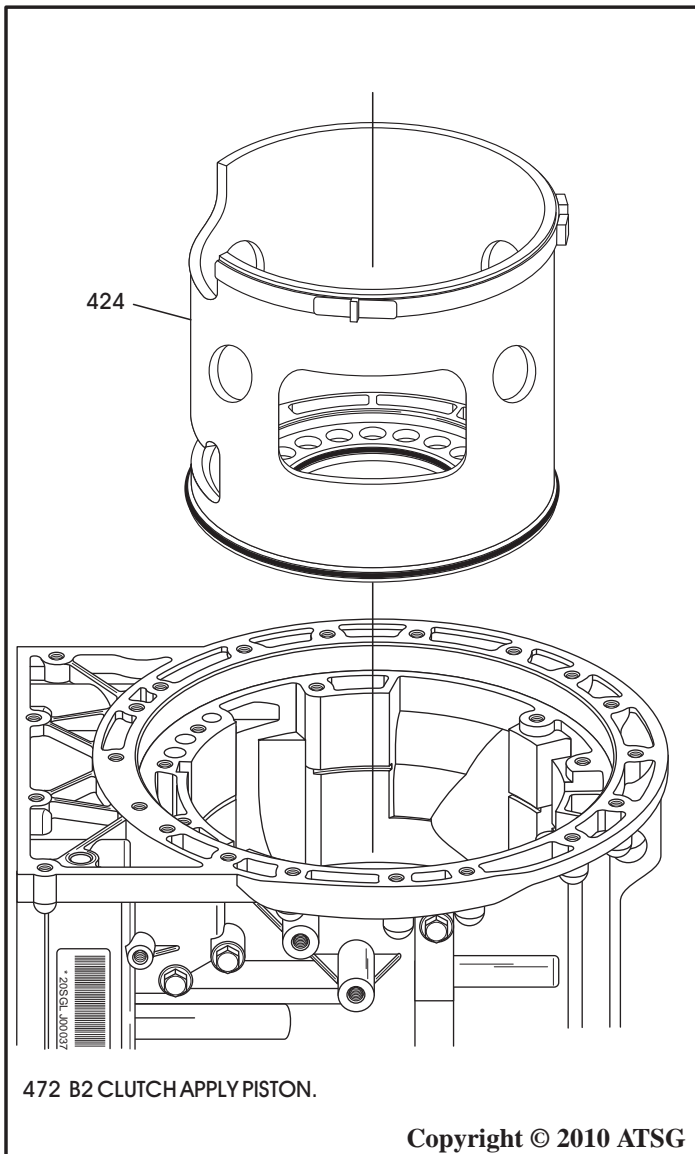

Figure 75

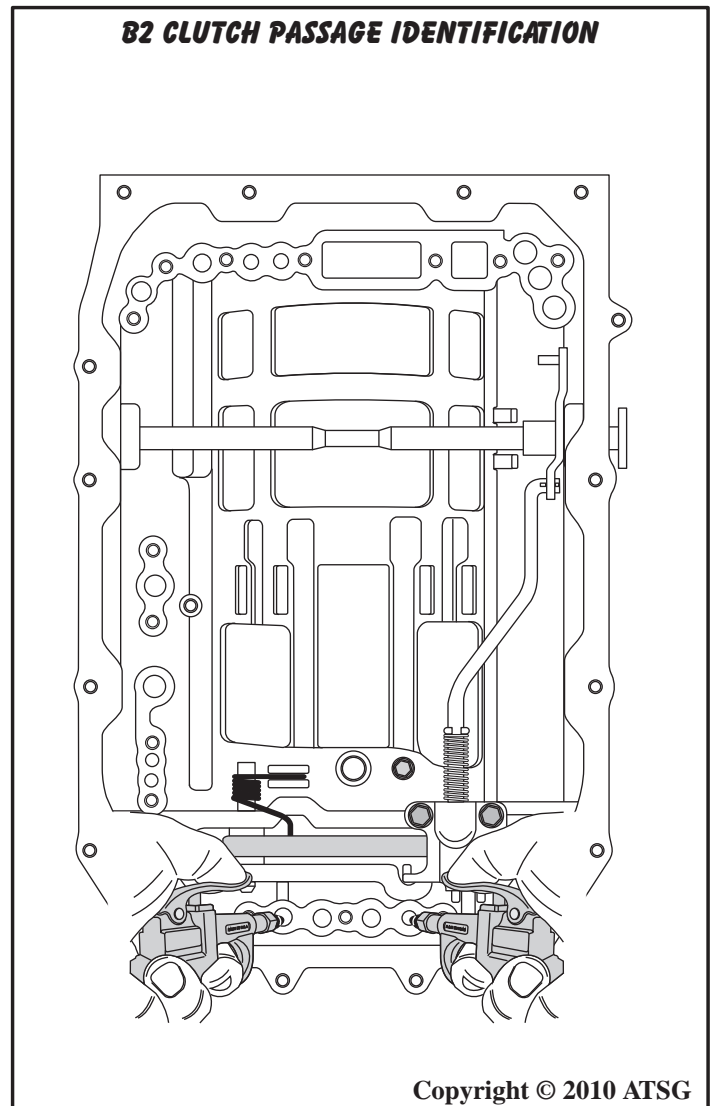

Figure 76

TRANSMISSION DISASSEMBLY (CONT'D)

76. Remove and discard the three "O" ring seals on the B2 clutch piston, as shown in Figure 77.
 77. Remove and discard the rear transmission seal, as shown in Figure 78.
 78. The rear transmission bearing is retained with a snap ring, as shown in Figure 78.
 79. Replace the rear transmission ball bearing as necessary.
- Note: The 2WD and 4WD rear ball bearings have different inside diameters.**

This Concludes Transmission Disassembly

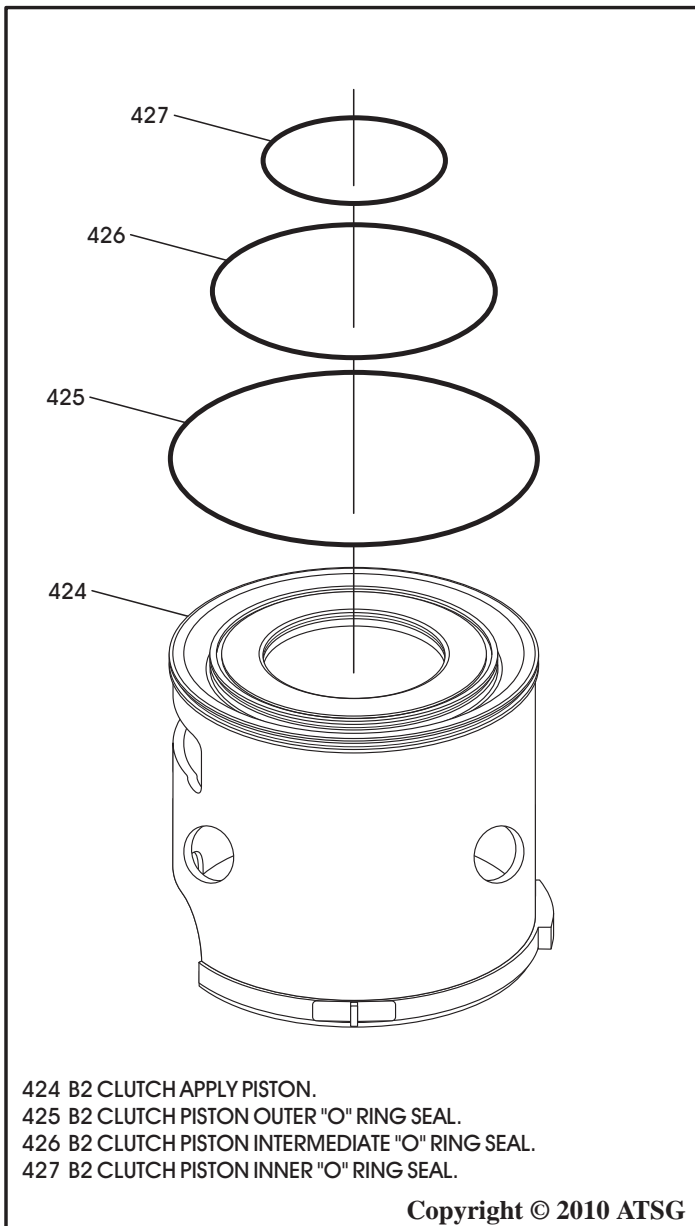

Figure 77

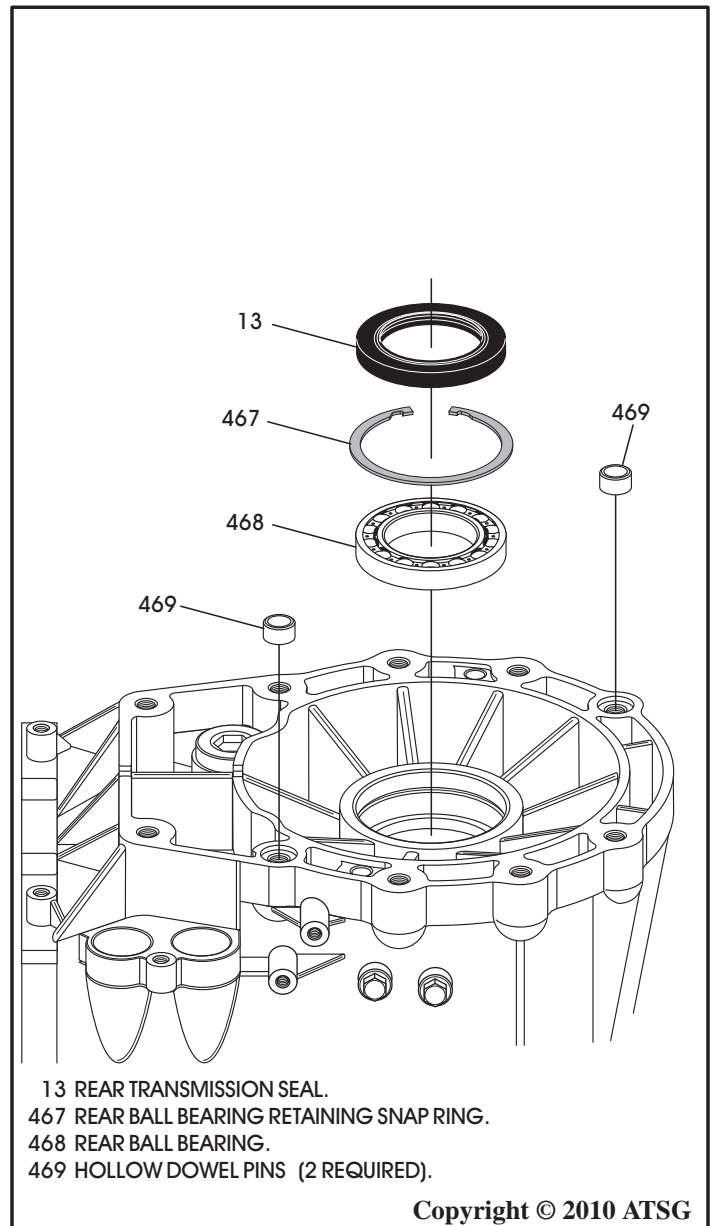

Figure 78

COMPONENT REBUILD

TRANSMISSION CASE ASSEMBLY

1. Install three new "O" ring seals onto B2 clutch apply piston, as shown in Figure 79, and lube with small amount of Trans-Jel®.
2. Lubricate case seal surfaces with a small amount of Trans-Jel®, to prevent seal damage.
3. Install the B2 clutch apply piston into the case, as shown in Figure 80.

Note: Piston must be installed with large tab at the 12-O-Clock position and the park pawl window at 6-O-Clock, as shown in Figure 80.

4. Install the return spring assembly and snap ring, as shown in Figure 80.
5. Compress the return spring assembly and install the snap ring into case groove and ensure it is fully seated.

Continued on Page 53

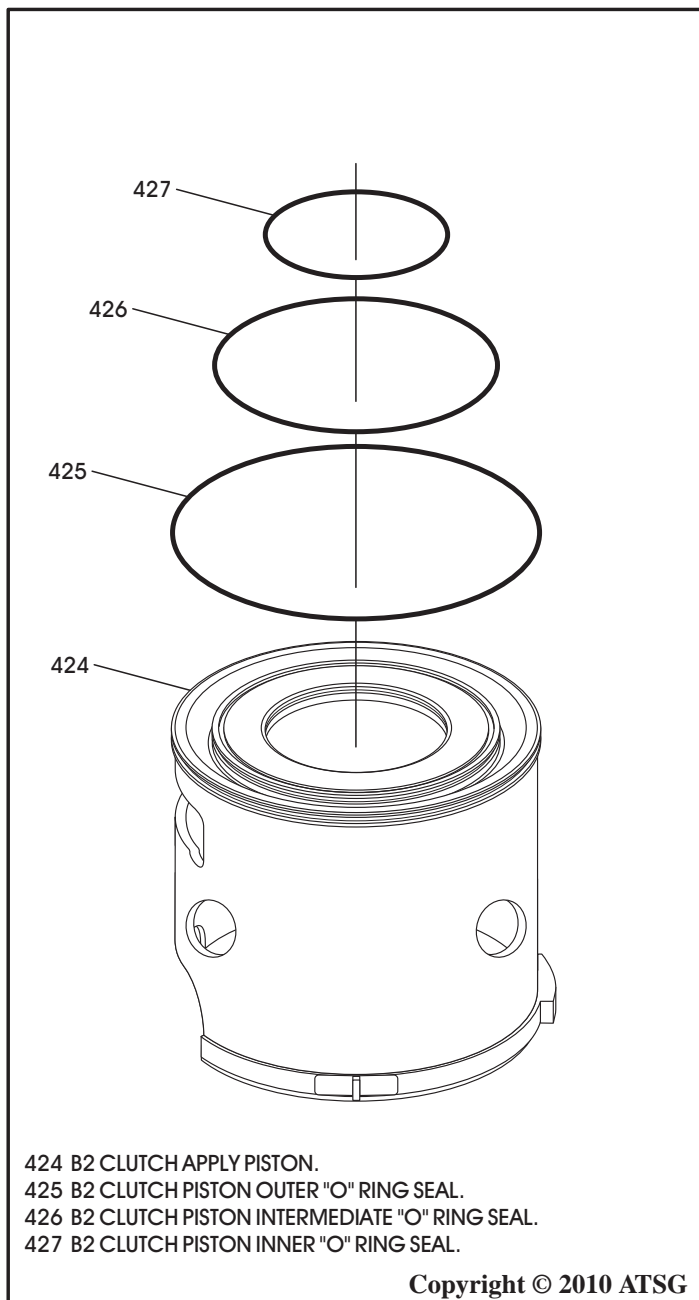

Figure 79

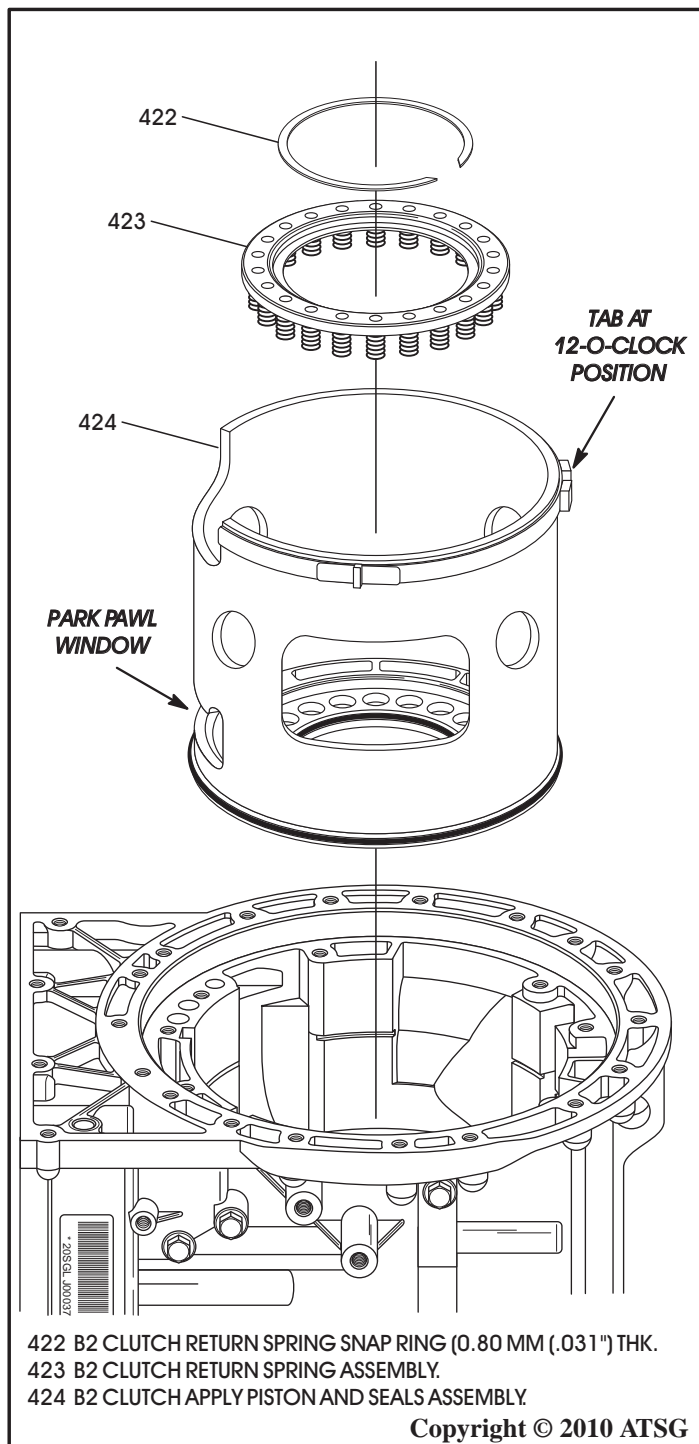

Figure 80

COMPONENT REBUILD (CONT'D)

TRANSMISSION CASE ASSEMBLY (CONT'D)

6. Install new rear ball bearing as necessary, as shown in Figure 81.
Note: The 2WD and 4WD rear ball bearings have different inside diameters.
7. Install the rear ball bearing retaining snap ring into case groove, as shown in Figure 81.
8. Install new rear transmission seal, as shown in Figure 81, using the proper seal driver.
9. Install the inside detent lever spacer and detent spring, if it was removed (See Figure 82), and torque to 11 N·m (97 in.lb.).
10. Install *two* new manual shaft seals, as shown in Figure 82.

11. Install the parking pawl and park pawl pivot pin into the case, as shown in Figure 82.
12. Rotate parking pawl on pivot pin to the straight up position and install return spring over pivot pin, against "E" clip and under parking pawl.

Continued on Page 55

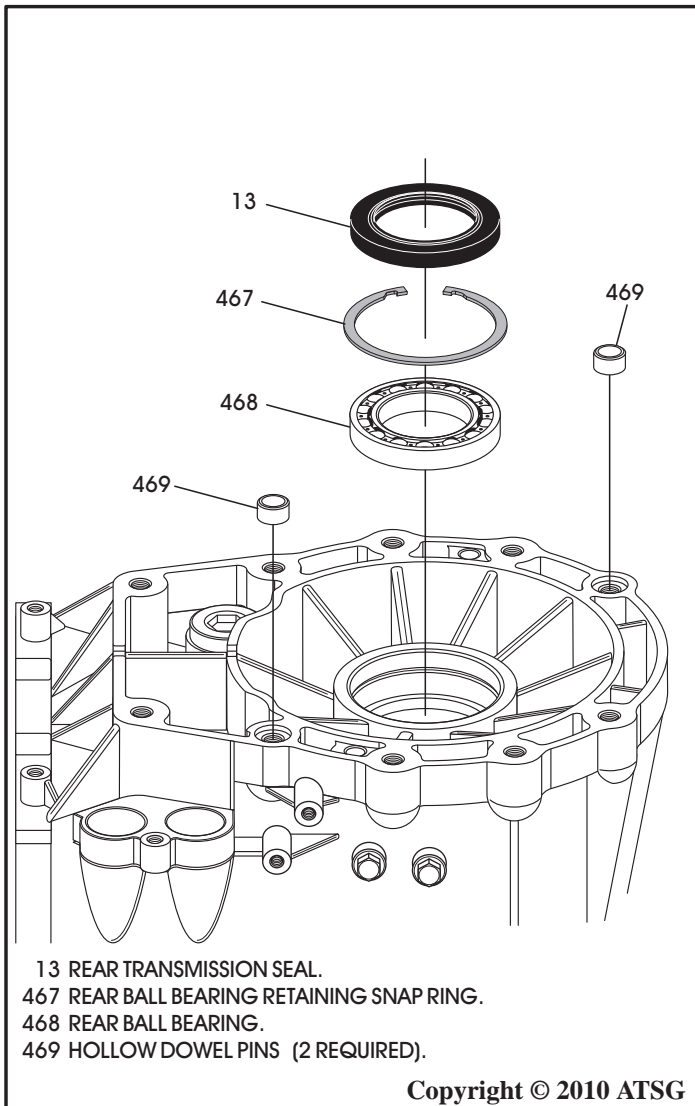

Figure 81

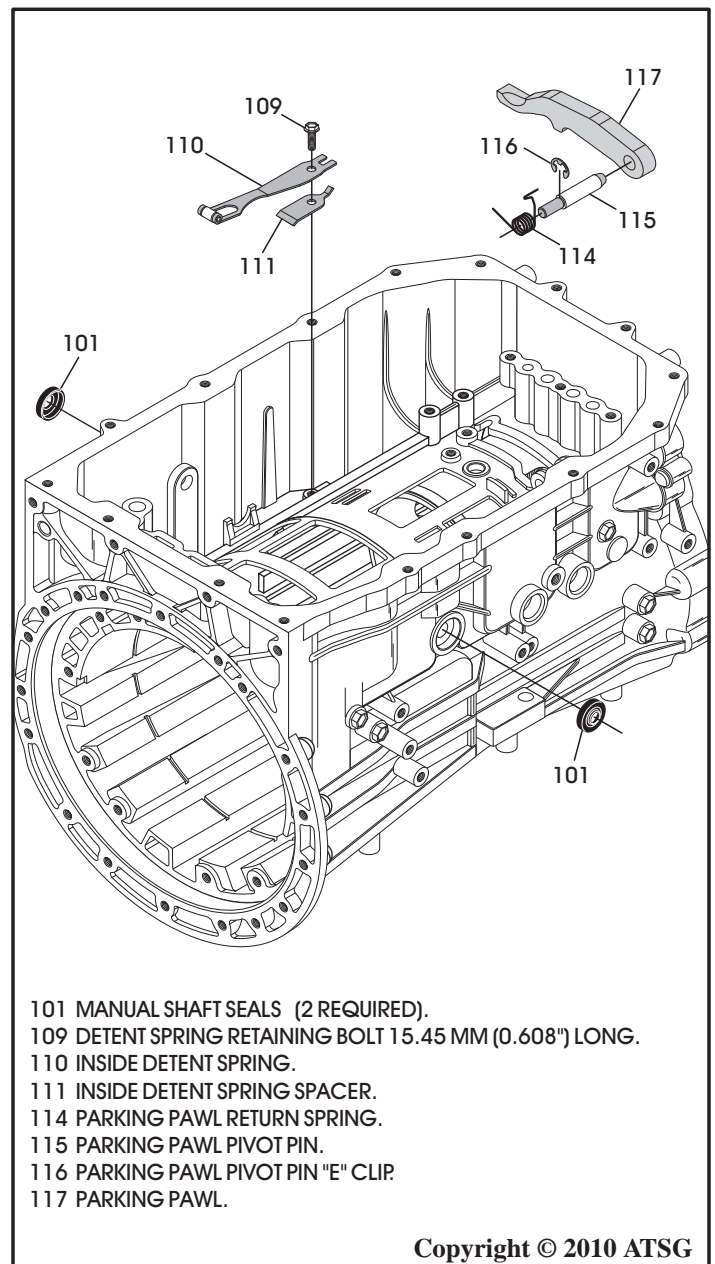
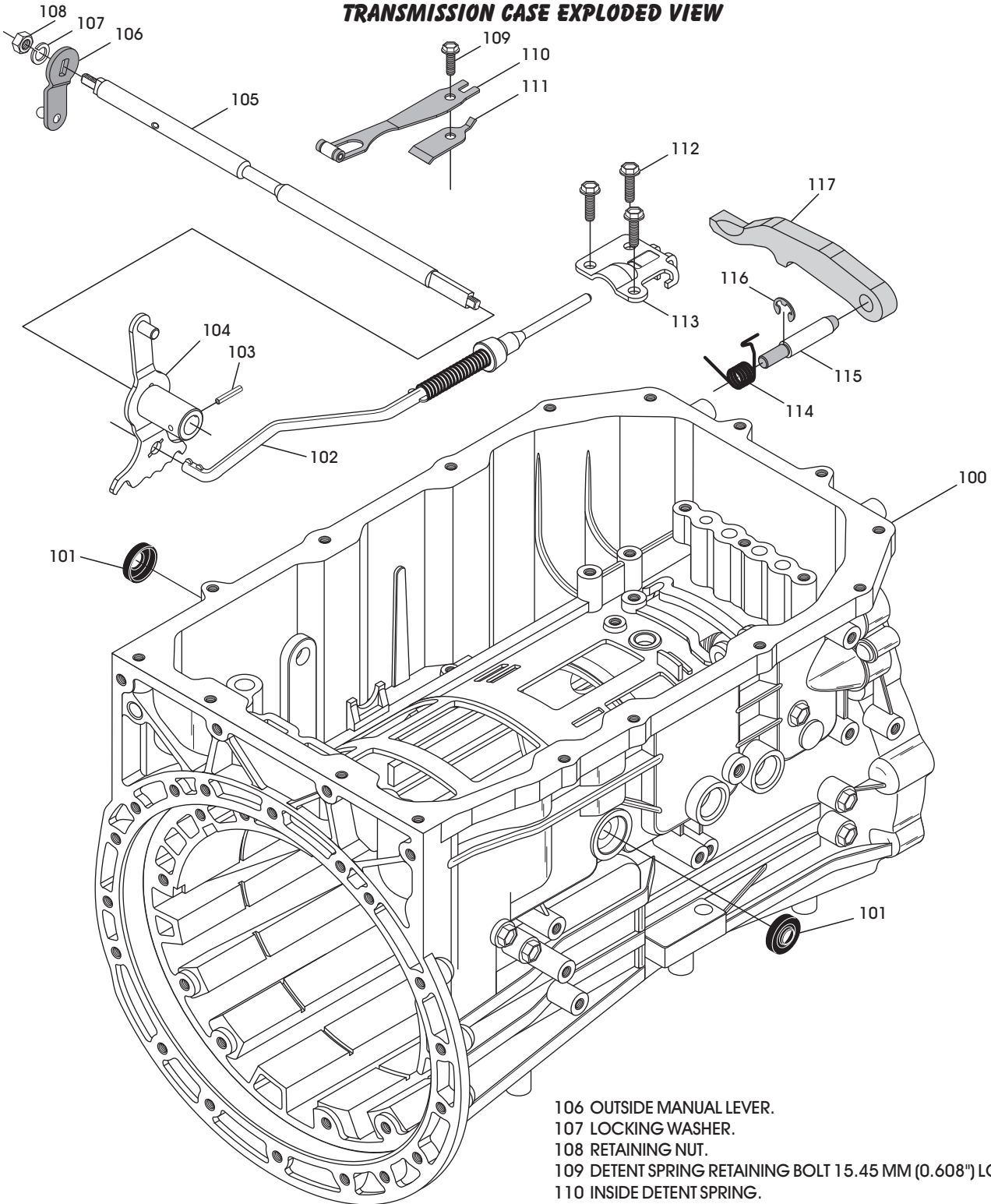

Figure 82

TRANSMISSION CASE EXPLODED VIEW



- 100 TRANSMISSION CASE ASSEMBLY.
- 101 MANUAL SHAFT SEALS (2 REQUIRED).
- 102 PARKING ROD AND ACTUATOR ASSEMBLY.
- 103 ROLLED PIN.
- 104 INSIDE DETENT LEVER.
- 105 MANUAL SHAFT.

- 106 OUTSIDE MANUAL LEVER.
- 107 LOCKING WASHER.
- 108 RETAINING NUT.
- 109 DETENT SPRING RETAINING BOLT 15.45 MM (0.608") LONG.
- 110 INSIDE DETENT SPRING.
- 111 INSIDE DETENT SPRING SPACER.
- 112 ACTUATOR GUIDE RETAINING BOLT, 18.45 MM (0.726") (3 REQ).
- 113 PARKING ROD ACTUATOR GUIDE.
- 114 PARKING PAWL RETURN SPRING.
- 115 PARKING PAWL PIVOT PIN.
- 116 PARKING PAWL PIVOT PIN "E" CLIP.
- 117 PARKING PAWL.

Copyright © 2010 ATSG

Figure 83

COMPONENT REBUILD (CONT'D)

TRANSMISSION CASE ASSEMBLY (CONT'D)

13. Rotate parking pawl down into position, against spring tension, and install inside detent lever and the park rod and actuator, as shown in Figure 83.
Note: Park rod must be on the top side of the parking pawl.
14. Lube with a small amount of Trans-Jel® and install the manual shaft through the case bore and inside detent lever, as shown in Figure 83.
15. Align and install the rolled pin through inside detent lever and the manual shaft, as shown in Figure 83.
16. Install the park rod guide on top of the park rod, as shown in Figure 83, and torque the three bolts to 28 N·m (20 ft.lb.).

17. After installation, the return spring must be on back side of the case tab and underneath the parking pawl, as shown in Figure 84.
18. After installation, park rod must be underneath the park rod guide and on top of parking pawl, as shown in Figure 85.

Continued on Page 56

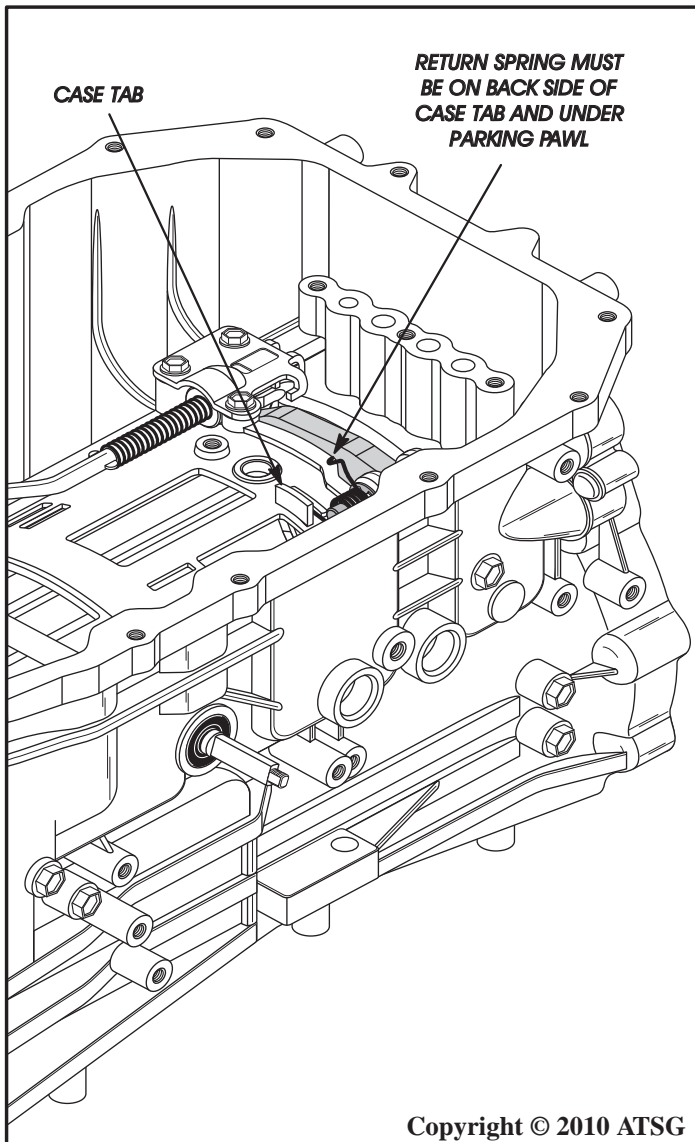

Figure 84

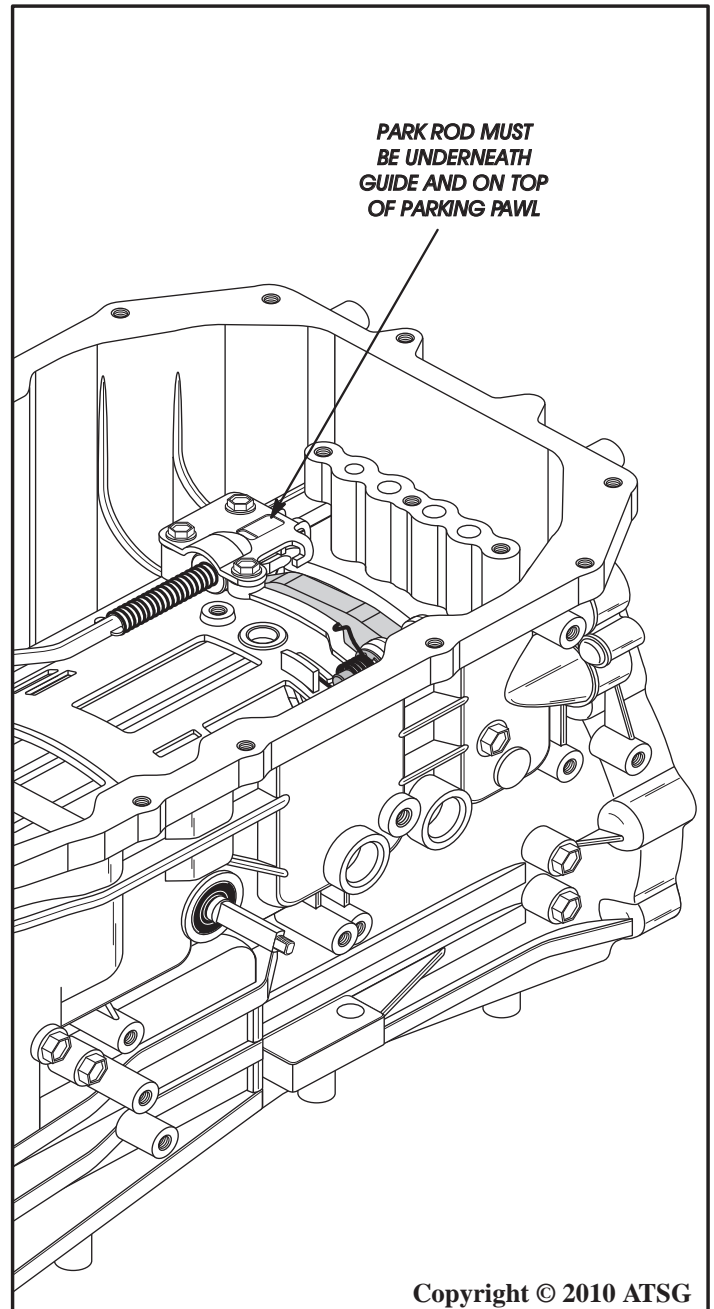

Figure 85

COMPONENT REBUILD (CONT'D)

TRANSMISSION CASE ASSEMBLY (CONT'D)

19. Install the number 13 thrust bearing race into and over case boss, as shown in Figure 86, and retain with Trans-Jel®.

Note: The number 13 thrust bearing will be installed on the output shaft.

20. Install output speed sensor and harness assembly into case, as shown in Figure 87.

21. Torque both bolts to 11 N·m (97 in.lb.).

22. Set the transmission case assembly aside for the final assembly process.

Component Rebuild
Continued on Page 57

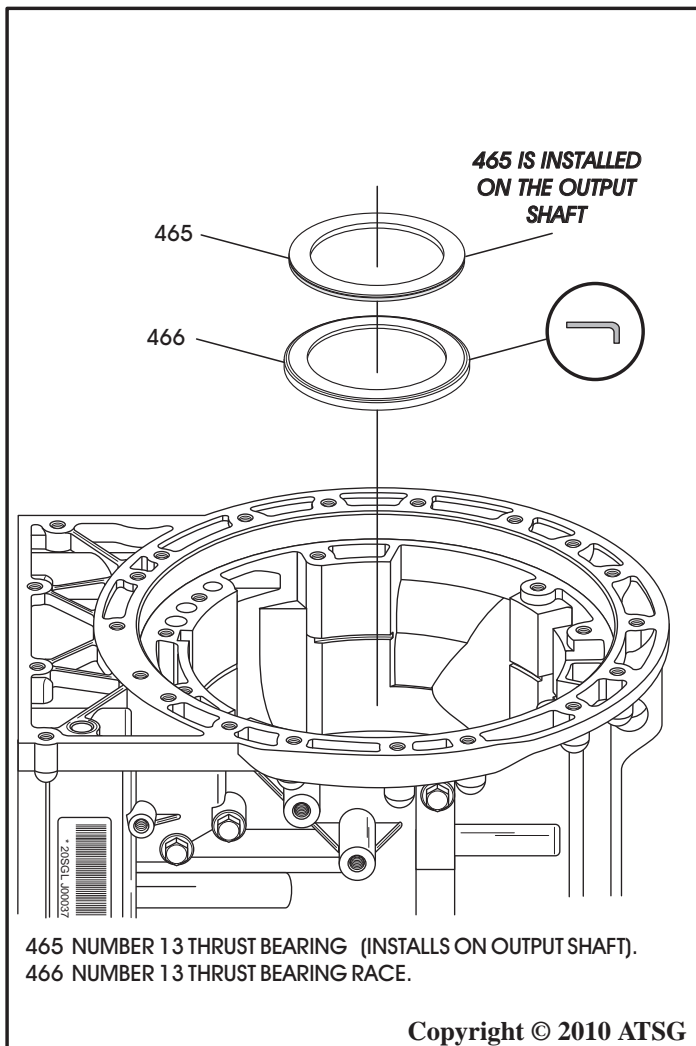

Figure 86

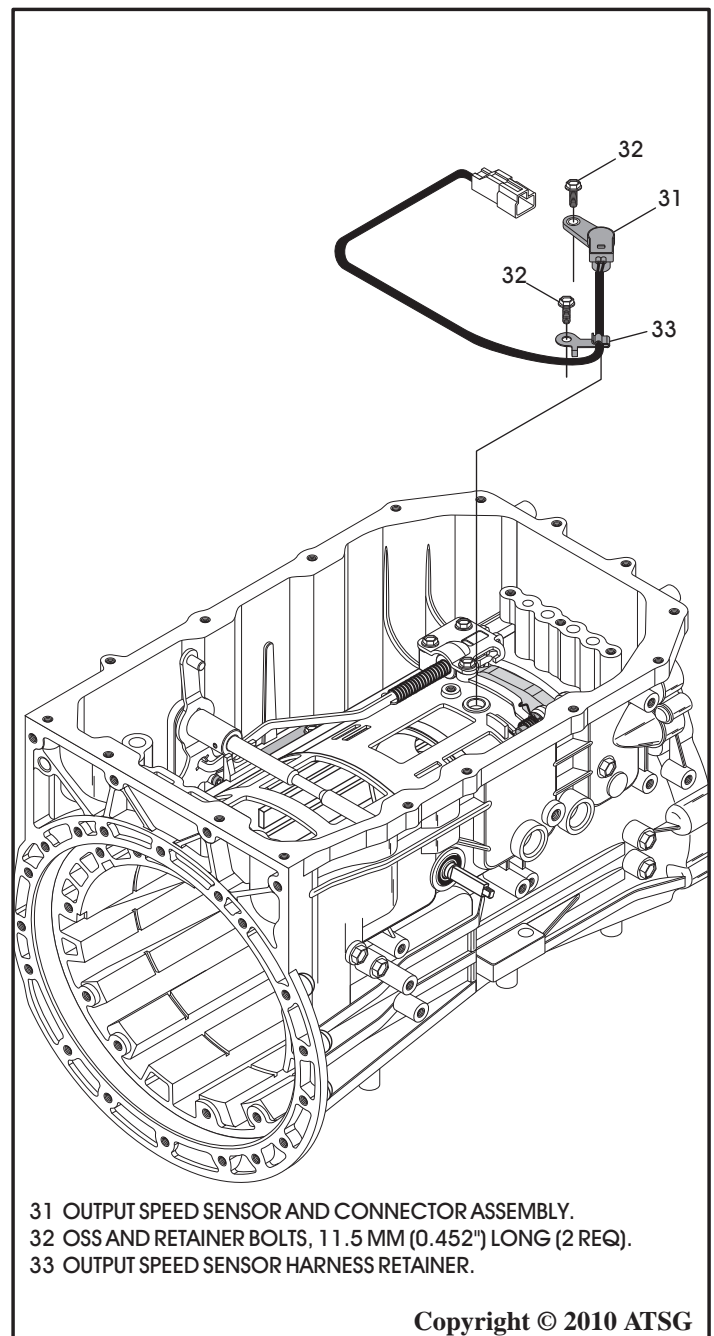

Figure 87

COMPONENT REBUILD (CONT'D)

K2 CLUTCH HOUSING

1. Disassemble the K2 clutch housing assembly using Figure 88 as a guide.
2. Clean all K2 clutch housing parts thoroughly and dry with compressed air.
3. Inspect all K2 clutch housing parts thoroughly for any wear and/or damage, and replace parts as necessary.

CAUTION: At the time of this printing, there are not any new "hard parts" available from the manufacturer for this unit. The only source will be used aftermarket suppliers.

Continued on Page 58

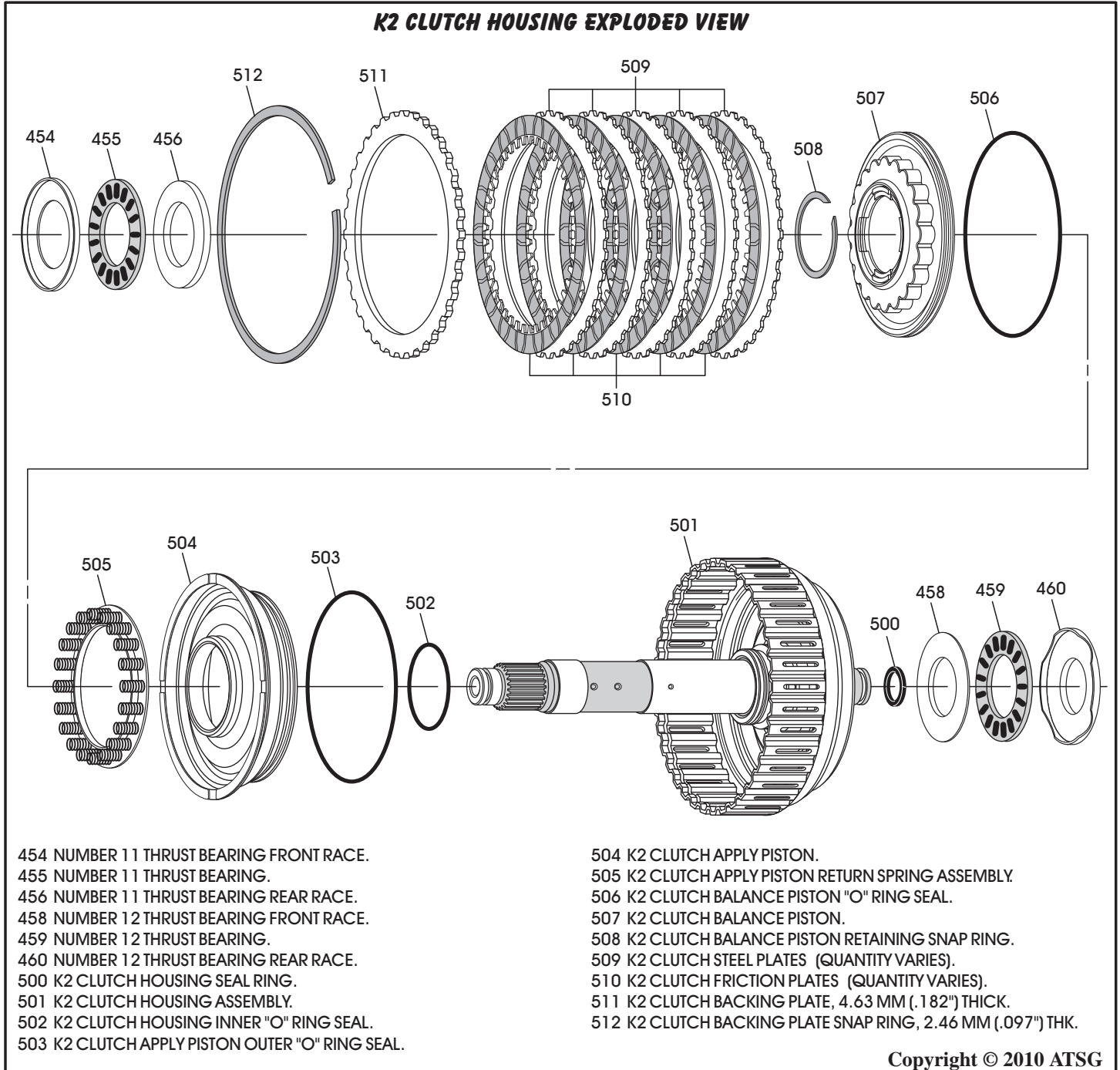

Figure 88

COMPONENT REBUILD (CONT'D)

K2 CLUTCH HOUSING (CONT'D)

4. Install new "O" ring seal onto the K2 clutch balance piston, as shown in Figure 89.
5. Turn the balance piston over and install the K2 clutch piston return spring assembly, as shown in Figure 90, and retain with liberal amount of Trans-Jel®.
6. Install new outer "O" ring seal onto K2 clutch apply piston, as shown in Figure 91.
7. Install new inner "O" ring seal into the lower groove in the K2 clutch housing, as shown in Figure 92.

Continued on Page 59

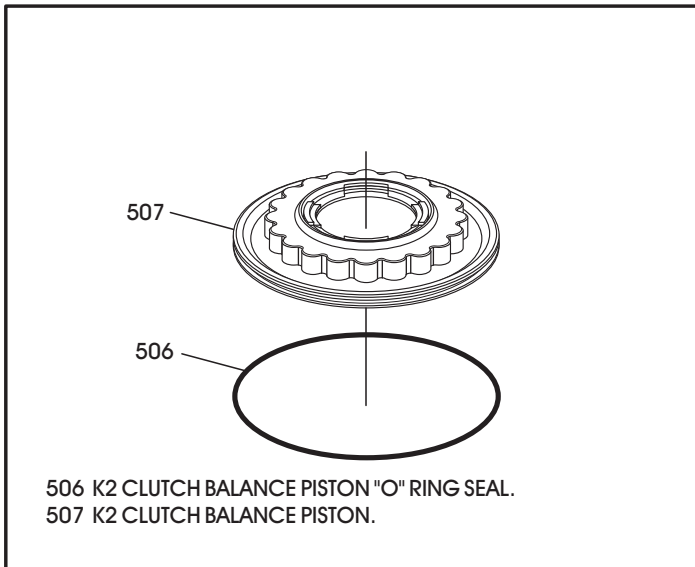

Figure 89

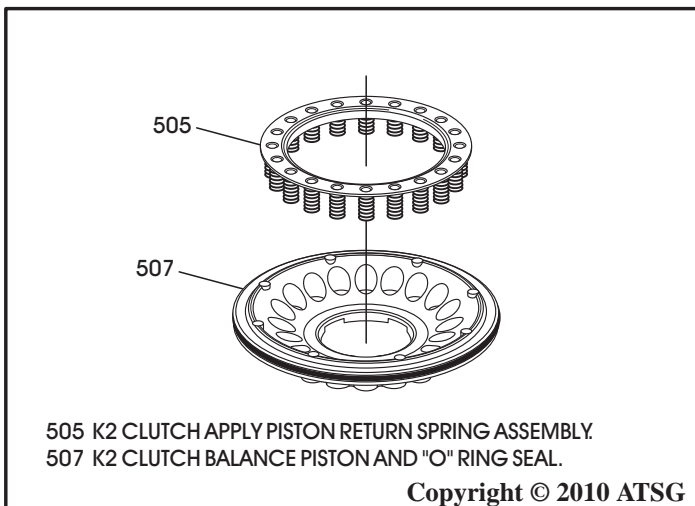

Figure 90

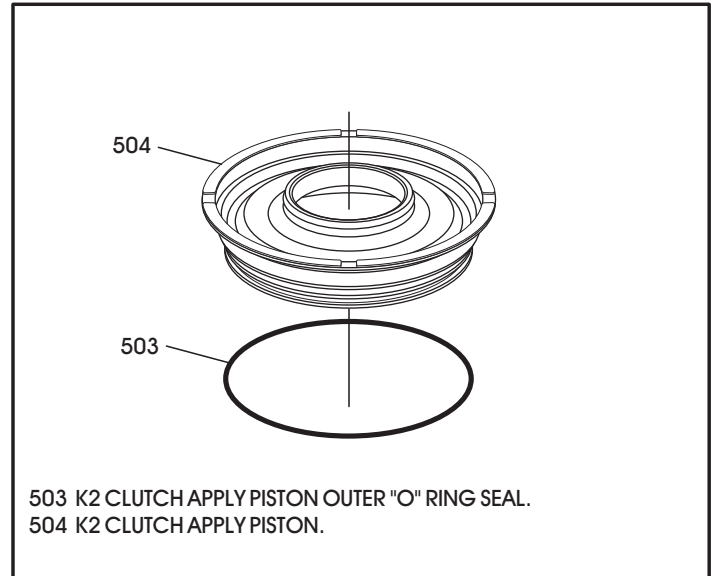

Figure 91

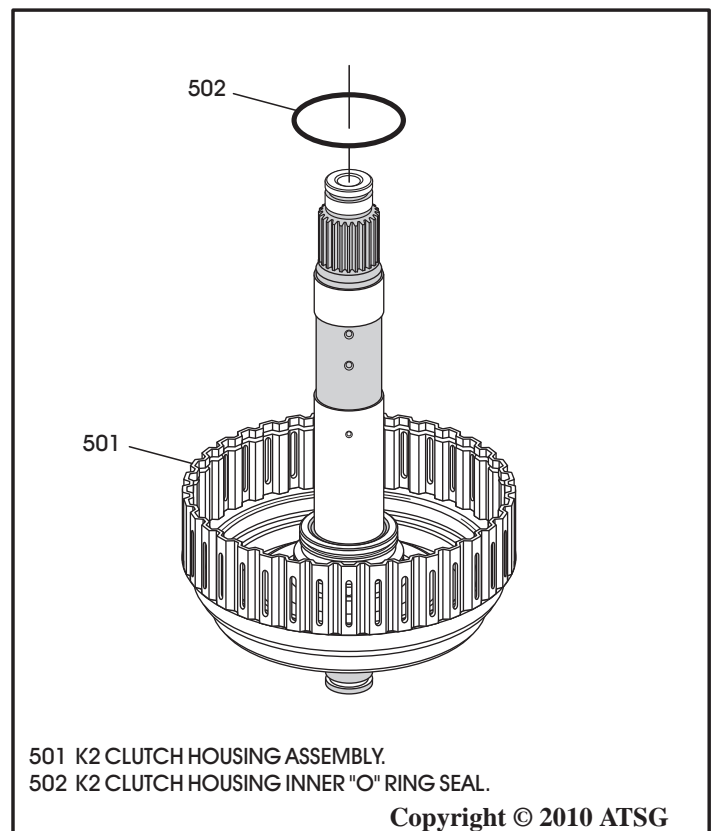

Figure 92

COMPONENT REBUILD (CONT'D)

K2 CLUTCH HOUSING (CONT'D)

8. Lube the piston seals and the seal surfaces in the housing with a small amount of Trans-Jel®.
9. Install the K2 clutch apply piston in K2 clutch housing, as shown in Figure 93.
10. Install the K2 balance piston and return spring assembly on top of the apply piston, as shown in Figure 93.
11. Compress balance piston and install snap ring, as shown in Figure 93.

Note: You may have to be innovative with your press adapters as this one is more difficult than some others because of the shaft.

12. Install the number 11 thrust bearing rear race and the number 11 thrust bearing, as shown in Figure 94, and retain with Trans-Jel®.
- Note:** This step can wait until the clutches are installed if you wish.
13. The number 11 thrust bearing front race will be installed on the rear planetary carrier during the assembly process.

Continued on Page 60

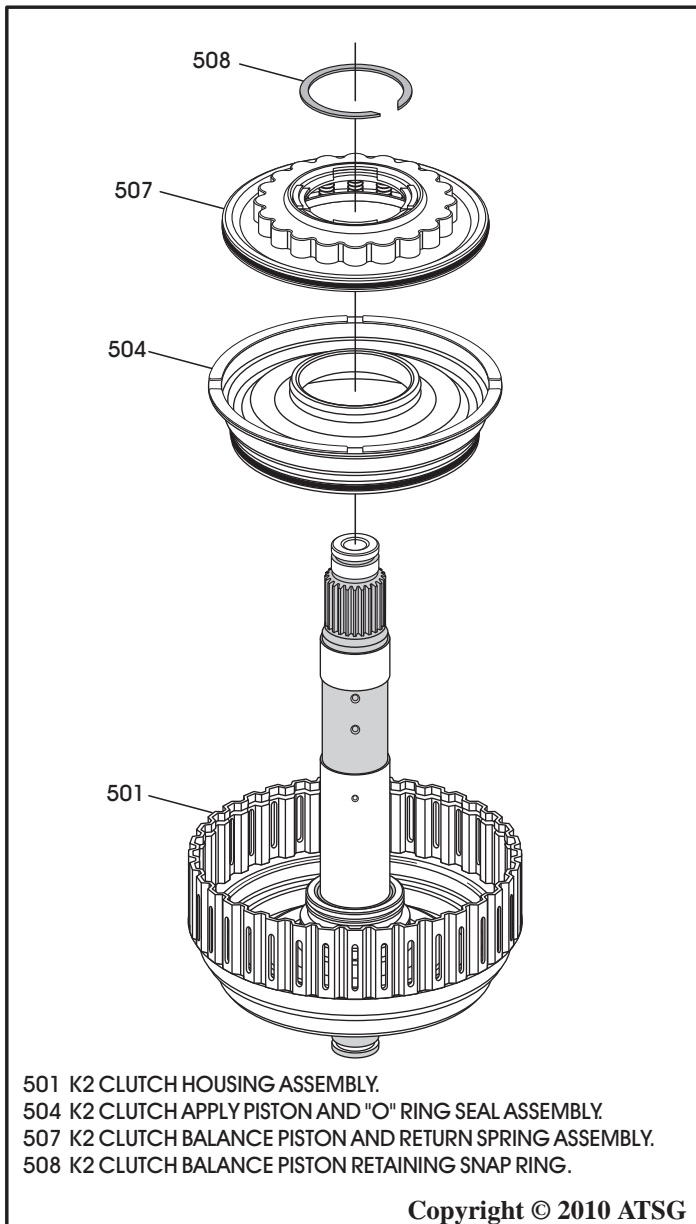

Figure 93

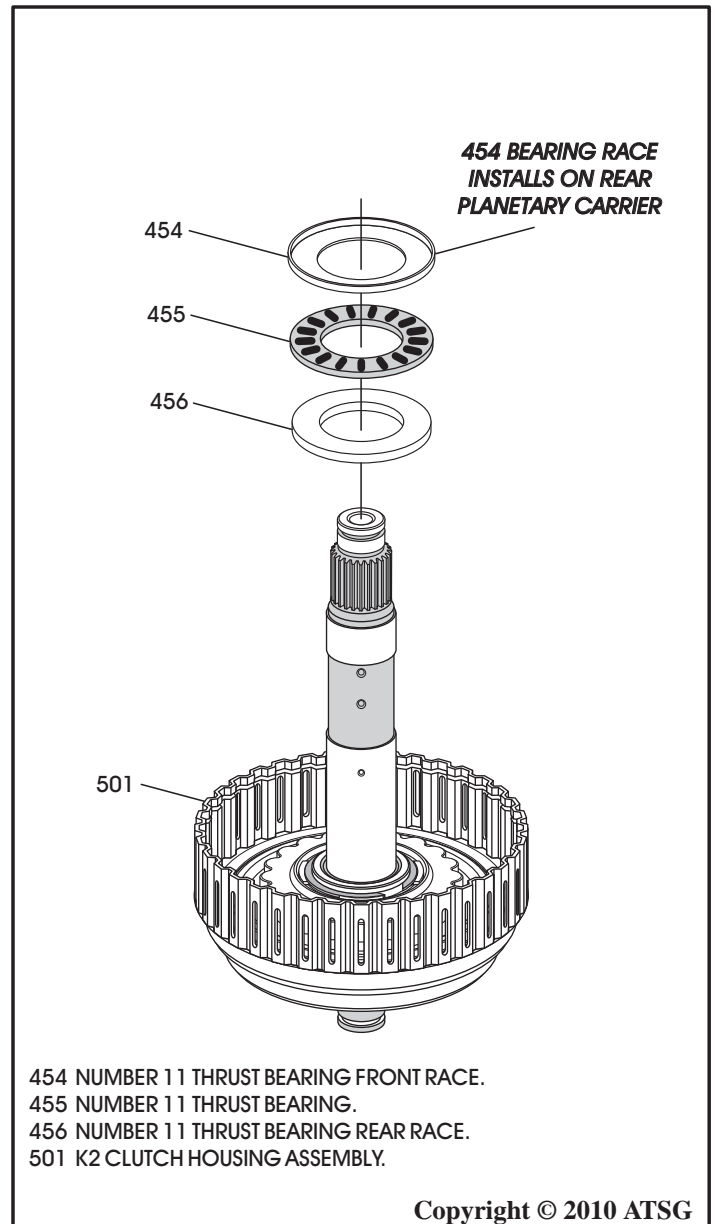

Figure 94

WWW.ALL-TRANS.BY

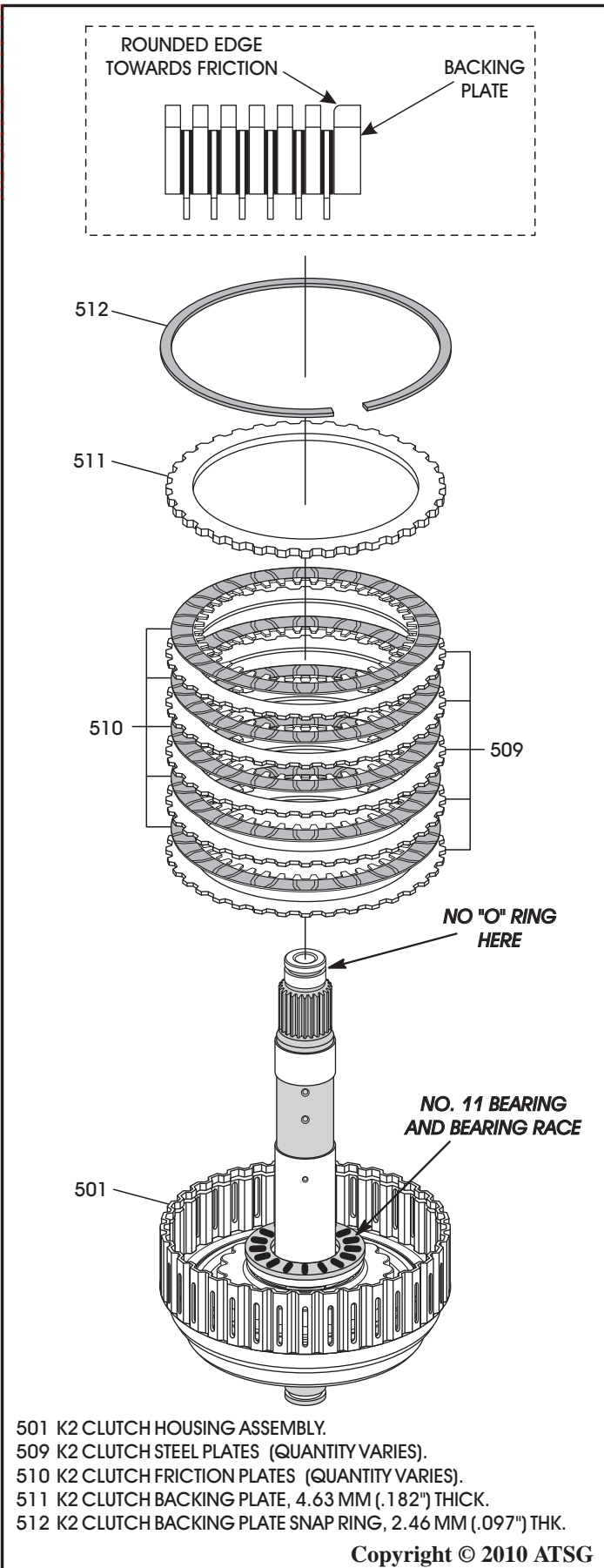

Figure 95

COMPONENT REBUILD (CONT'D)

K2 CLUTCH HOUSING (CONT'D)

14. Install the K2 clutch plates beginning with a steel plate and alternating with the friction plates, as shown in Figure 95, until you have the proper amount installed as quantity may vary.
Note: All friction plates should be soaked in proper fluid for 30 minutes before installing.
15. Install the K2 clutch backing plate, as shown in Figure 95, with the rounded edge toward the friction plate (See Figure 95).
16. Install the K2 clutch backing plate snap ring, as shown in Figure 95.
Note: There is no "O" ring in the groove of the pilot on the K2 clutch housing shaft, as shown in Figure 95.
17. Measure the K2 clutch clearance with a feeler gauge between the backing plate and snap ring, as shown in Figure 96.
Note: There are no factory clutch clearance specifications available, but the clearances were the "traditional" .010" per friction plate through-out this unit.
18. K2 clutch clearance should be approximately .010" per friction plate installed, as shown in Figure 96.

Continued on Page 61

K2 Clutch Clearance Should Be Approximately .010" Per Friction Plate

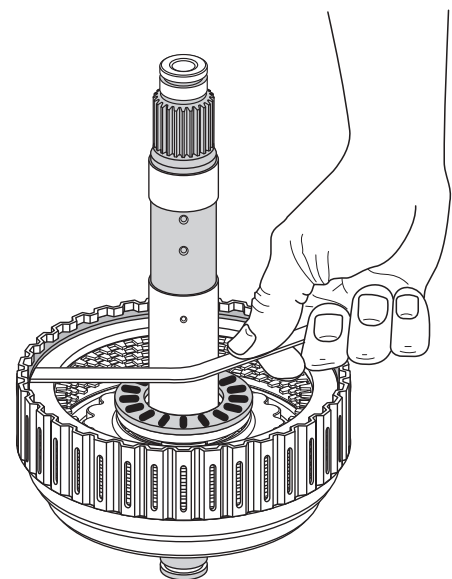

Copyright © 2010 ATSG

Figure 96

COMPONENT REBUILD (CONT'D)

K2 CLUTCH HOUSING (CONT'D)

19. Turn the K2 clutch assembly over and install the number 12 thrust bearing *front* race, as shown in Figure 97, and retain with Trans-Jel®.

Note: The number 12 thrust bearing and the rear race will be install in the output shaft.

20. Set the completed K2 clutch housing aside for the output shaft and rear ring gear component assembly process (See Figure 98).

Note: There is not an "O" ring that goes in the groove on pilot of the K2 clutch housing.

Continued on Page 62

COMPLETED K2 CLUTCH HOUSING

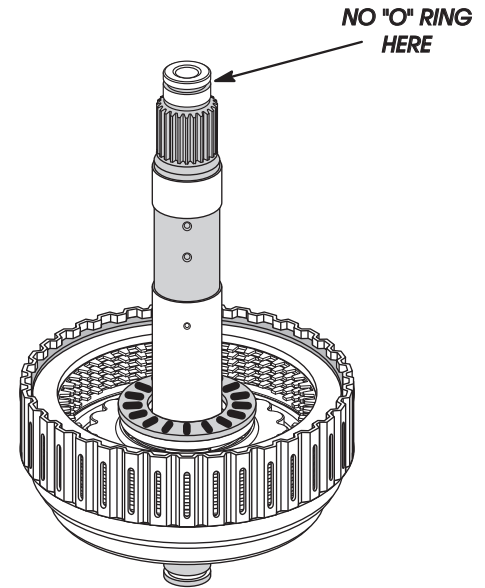

Copyright © 2010 ATSG

Figure 98

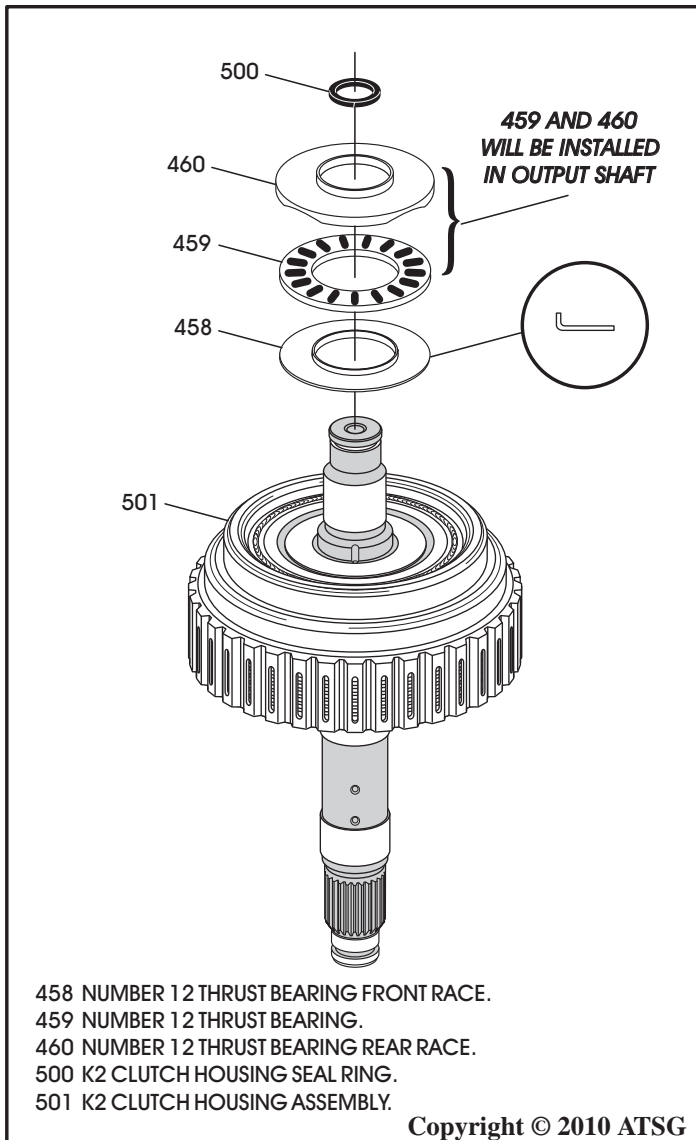

Figure 97

COMPONENT REBUILD (CONT'D)

The output shaft, the rear planetary ring gear and the K2 clutch housing are removed as an assembly and installed as an assembly. The K2 clutch housing cannot be removed without separating the rear planetary ring gear from the output shaft, and must be installed during the output shaft component rebuild section. They are connected with an internal snap ring in the output shaft that locks into an internal groove in the rear planetary ring gear.

Exploded view of all of these components is shown in Figure 99 below.

COMPONENT REBUILD (CONT'D)

OUTPUT SHAFT/REAR RING GEAR ASSEMBLY

1. Disassemble the output shaft/ring gear assembly using Figure 99 as a guide.
2. Clean all output shaft/ring gear parts thoroughly and dry with compressed air.
3. Inspect all output shaft/ring gear parts thoroughly for any wear and/or damage, and replace parts as necessary.

CAUTION: *At the time of this printing, there are not any new "hard parts" available from the manufacturer for this unit. The only source will be used aftermarket suppliers.*

Continued on Page 63

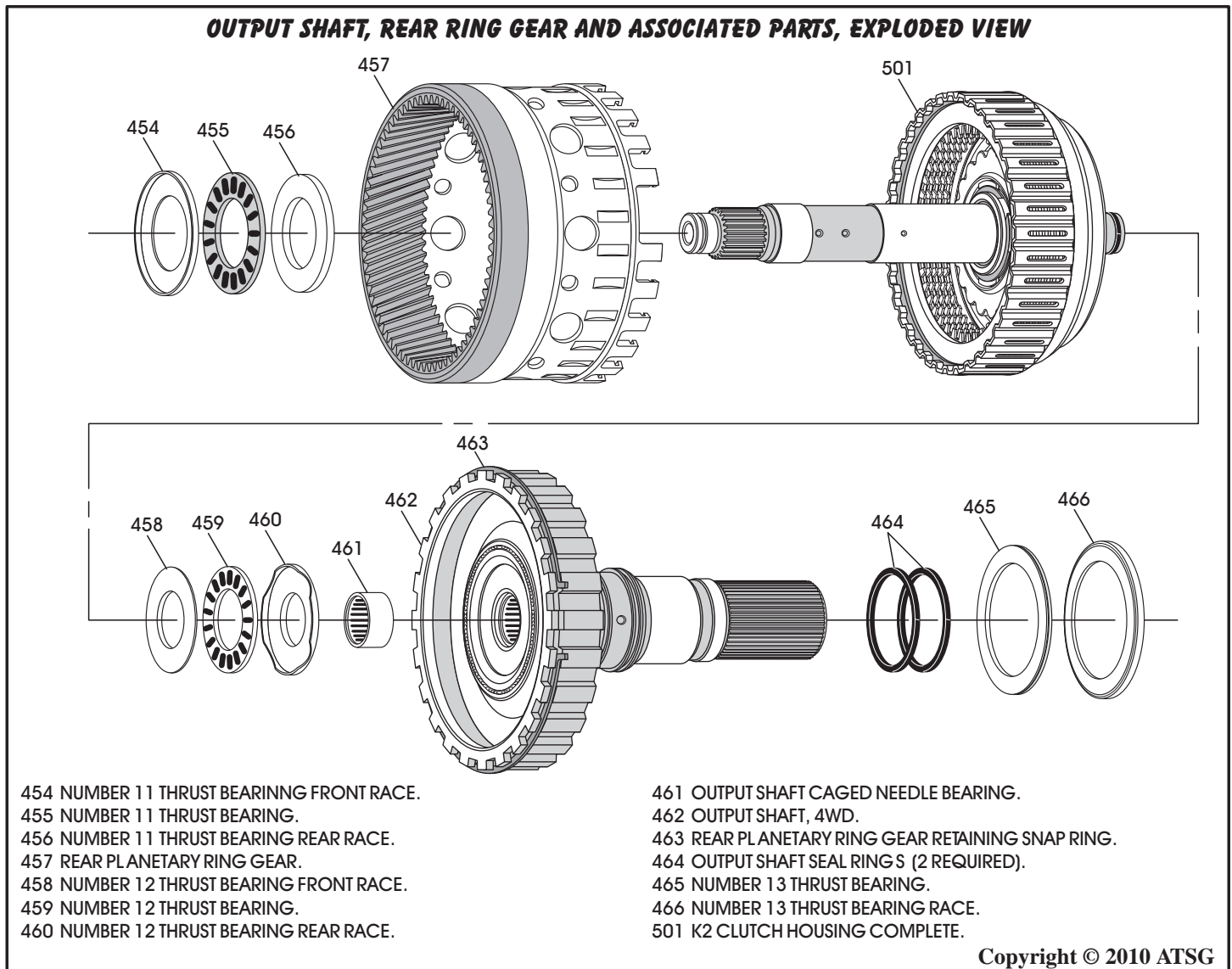

Figure 99

COMPONENT REBUILD (CONT'D) OUTPUT SHAFT/REAR RING GEAR ASSEMBLY (CONT'D)

4. If the caged needle bearing in output shaft needs replacement, try one of the local bearing supply houses. Number DB502405W is on the bearing, as shown in Figure 100.
 5. Install 2 new sealing rings on the output shaft, as shown in Figure 101.
 6. Install the number 13 thrust bearing on output shaft, as shown in Figure 101, retain with small amount of Trans-Jel®.
 7. Turn output shaft over and install the number 12 thrust bearing *rear* race and number 12 thrust bearing, as shown in Figure 102, retain with a small amount of Trans-Jel®.
- Note: The number 12 thrust bearing front race is installed on the K2 clutch housing.*

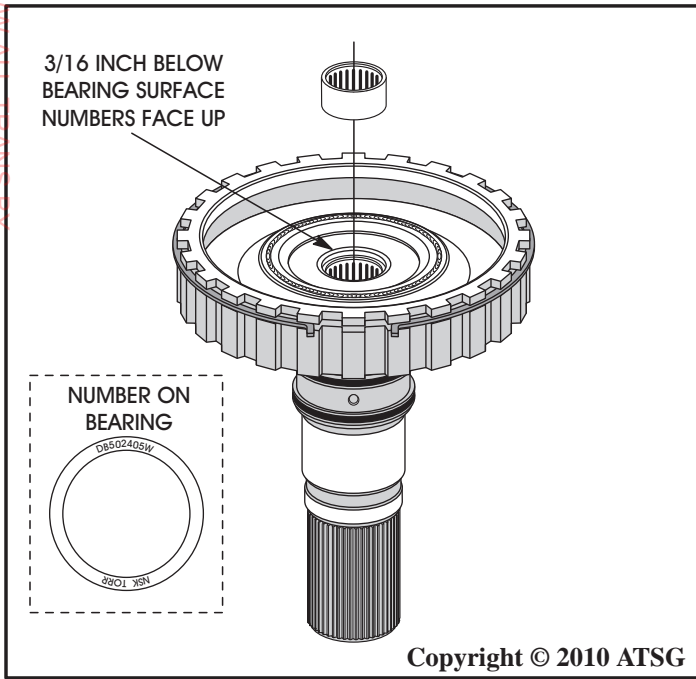

Figure 100

Continued on Page 64

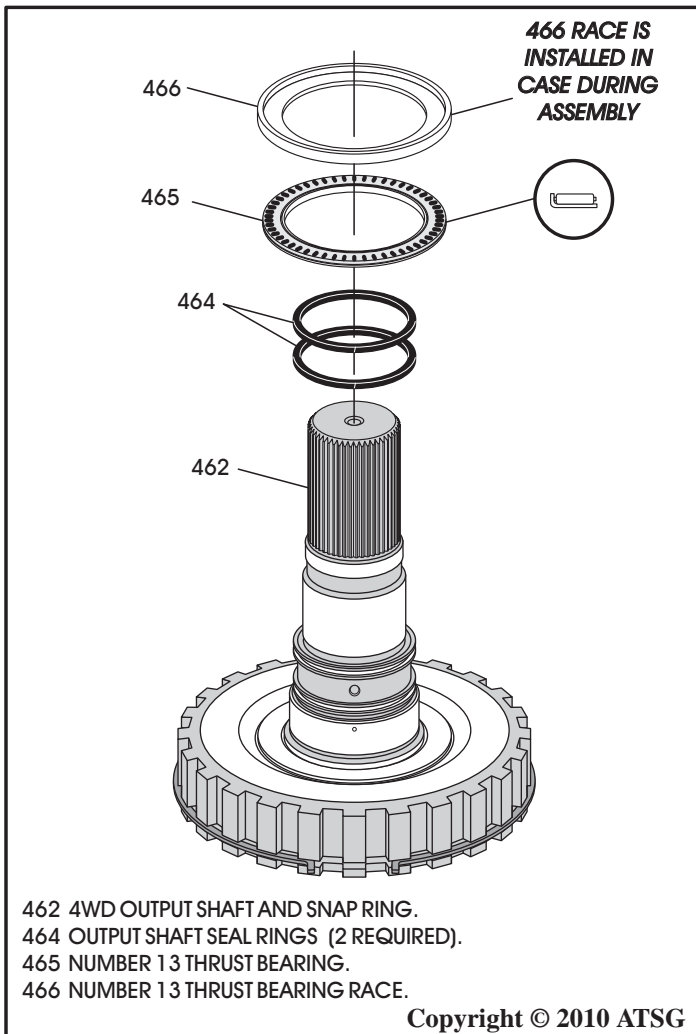

Figure 101

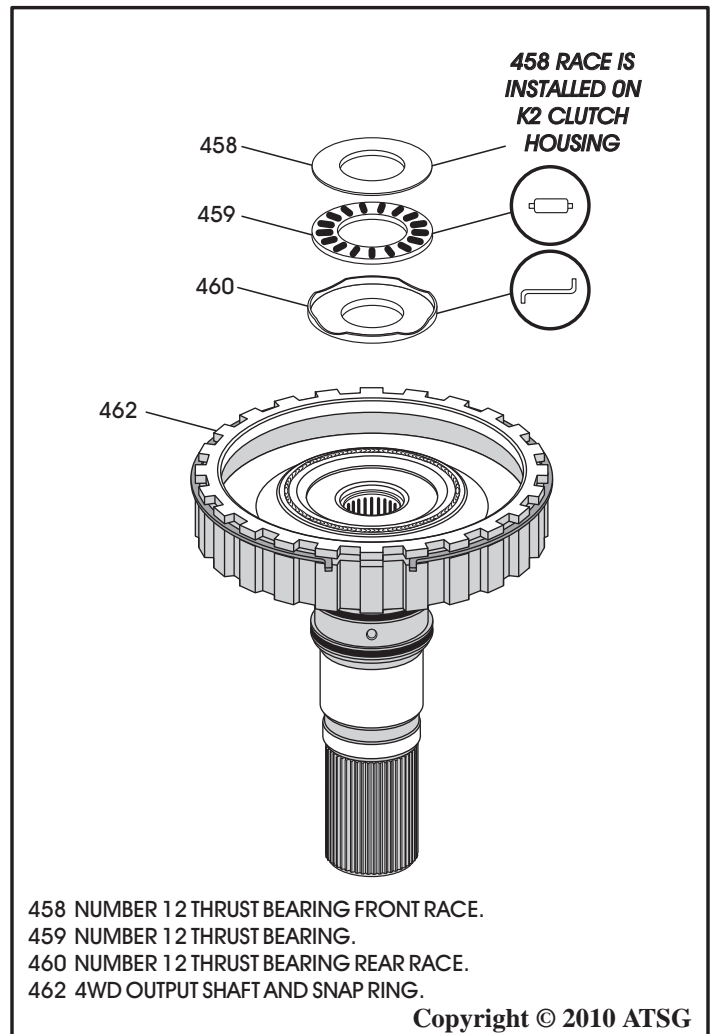

Figure 102

COMPONENT REBUILD (CONT'D)

OUTPUT SHAFT/REAR RING GEAR ASSEMBLY (CONT'D)

8. Ensure that the number 12 thrust bearing *front* race is still stuck to the K2 clutch housing, as shown in Figure 103.
9. Install the completed K2 clutch housing onto the output shaft, as shown in Figure 103.
10. Install the rear planetary ring gear, with one of wide slots toward the opening in the snap ring, as shown in Figure 104, and onto the tabs on the output shaft.

11. Squeeze the snap ring together using needle nose pliers, as shown in Figure 104, and tap ring gear with a small hammer if necessary.
Note: Ensure that snap ring is fully seated in the internal groove of the rear ring gear.
12. Set completed output shaft, rear planetary ring gear and K2 clutch housing assembly aside for final assembly process (See Figure 105).

**Component Rebuild
Continued on Page 65**

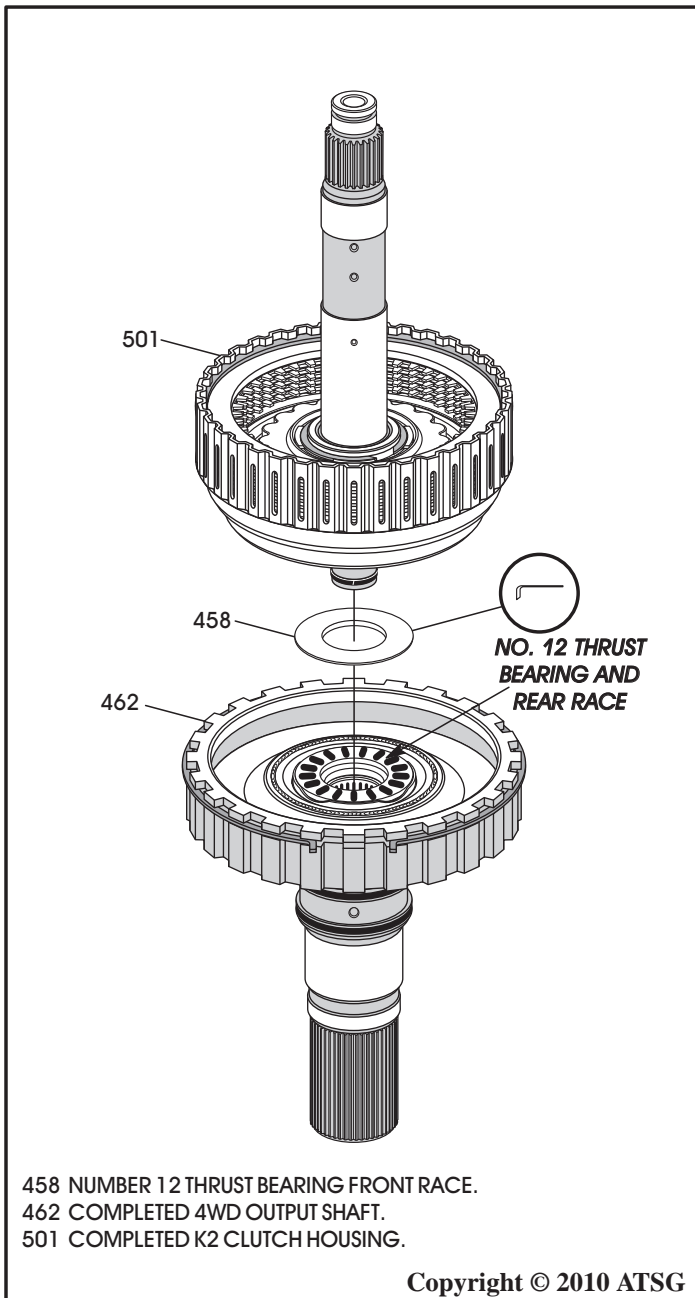

Figure 103

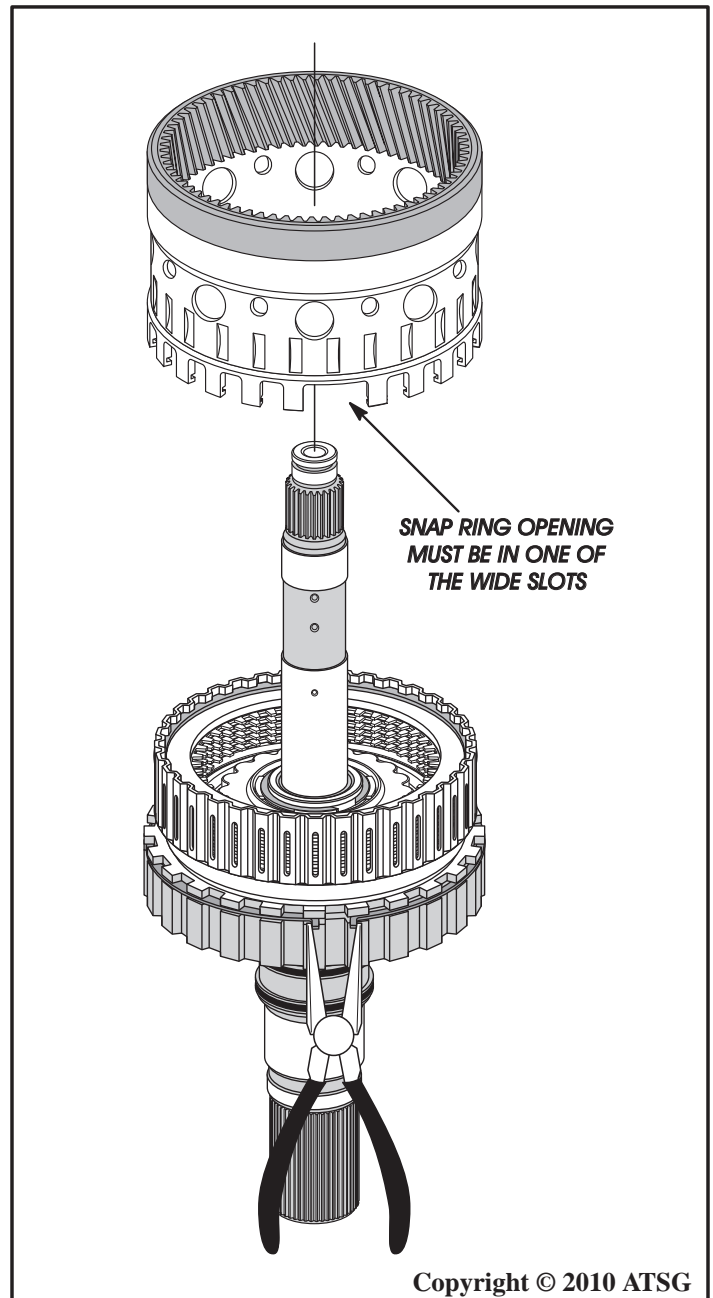
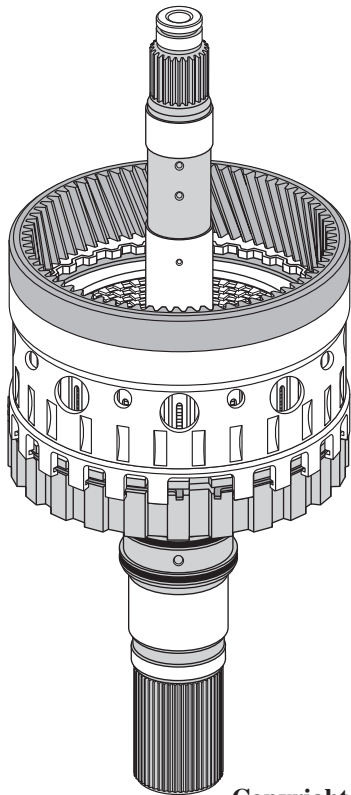

Figure 104

COMPLETED OUTPUT SHAFT, REAR PLANETARY RING GEAR AND K2 CLUTCH HOUSING



Copyright © 2010 ATSG

Figure 105

COMPONENT REBUILD (CONT'D) REAR PLANETARY ASSEMBLY

1. Clean all rear planetary carrier parts thoroughly and dry with compressed air (See Figure 108).
2. Inspect all rear planetary carrier parts thoroughly for any wear and/or damage, and replace parts as necessary.
3. **CAUTION:** *At the time of this printing, there are not any new "hard parts" available from the manufacturer for this unit. The only source will be used aftermarket suppliers.*
4. Install number 10 thrust bearing into bottom of planetary carrier with the needles facing up, as shown in Figure 106.
Note: Number 10 thrust bearing race will be installed on small sun gear.
5. Install the sprag inner race spacer, as shown in Figure 106.
6. Install the split "wave" spring on top of sprag inner race spacer, as shown in Figure 106.
7. Set the completed rear planetary carrier aside for the final assembly process.

Continued on Page 66

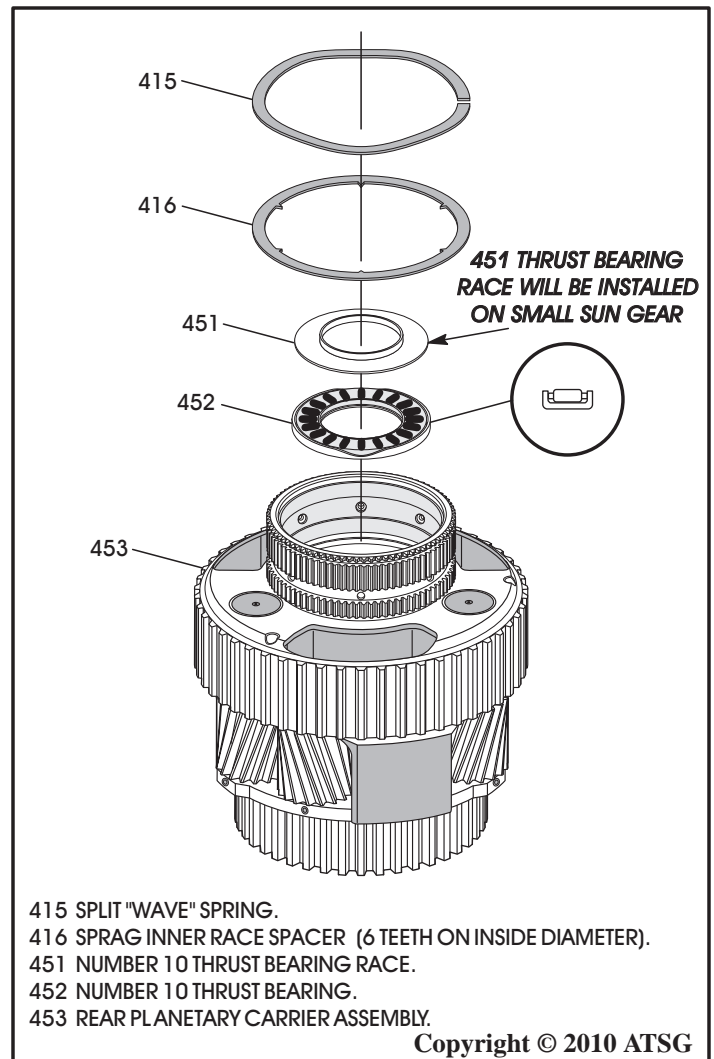

- 415 SPLIT "WAVE" SPRING.
- 416 SPRAG INNER RACE SPACER (6 TEETH ON INSIDE DIAMETER).
- 451 NUMBER 10 THRUST BEARING RACE.
- 452 NUMBER 10 THRUST BEARING.
- 453 REAR PLANETARY CARRIER ASSEMBLY.

Copyright © 2010 ATSG

Figure 106

COMPLETED REAR PLANETARY CARRIER

SPRAG RACE SPACER AND WAVE SPRING

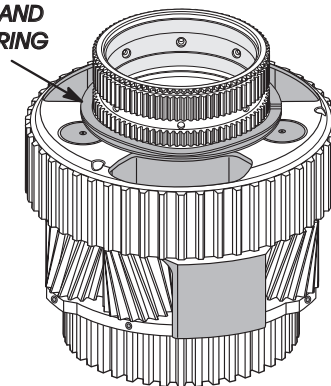

Copyright © 2010 ATSG

Figure 107

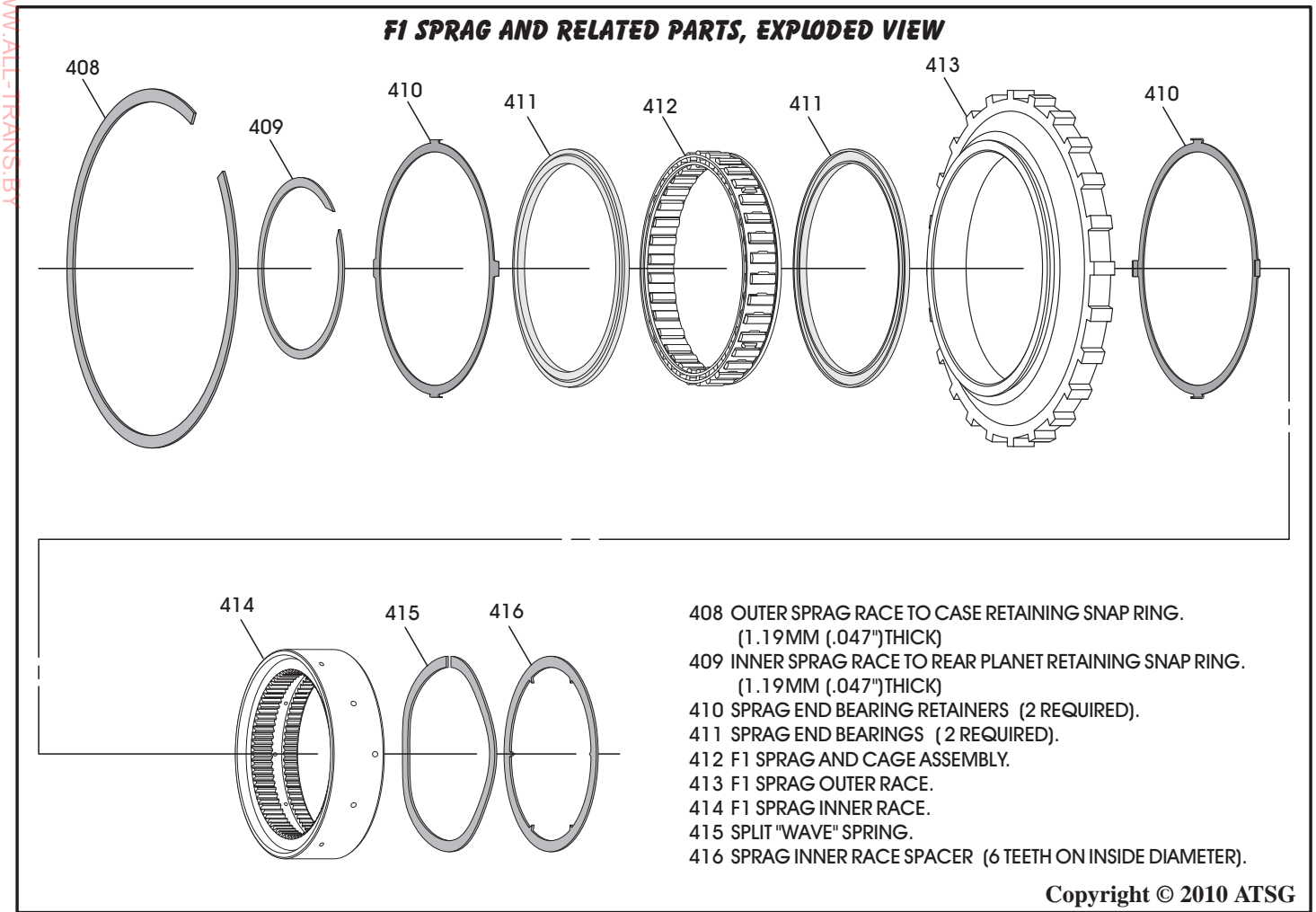

Figure 108

COMPONENT REBUILD (CONT'D)

F1 SPRAG ASSEMBLY

1. Disassemble the complete F1 sprag assembly using Figure 108 as a guide.
2. Clean all F1 sprag assembly parts thoroughly and dry with compressed air.
3. Inspect all F1 sprag assembly parts thoroughly for any wear and/or damage, and replace parts as necessary.
Caution: At the time of this printing, there are not any new "hard parts" available from the manufacturer for this unit. The only source will be used aftermarket suppliers.
4. Install one end bearing retainer on the **back** side of the sprag outer race, as shown in Figure 109.

Continued on Page 67

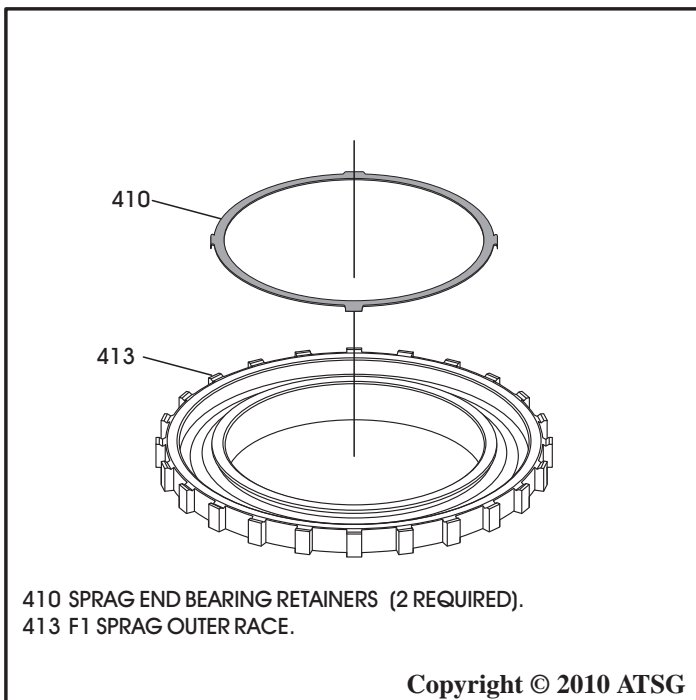

Figure 109

COMPONENT REBUILD (CONT'D)

F1 SPRAG ASSEMBLY (CONT'D)

5. Turn the outer race and retainer over, as shown in Figure 110, and install sprag end bearing with groove facing up.
6. Install the F1 sprag assembly with lip facing down and "windows" to the right, as shown in Figure 110.
7. Install the second end bearing with the groove facing down, as shown in Figure 110.
8. Install the second end bearing retainer, as shown in Figure 110, by snapping into place and ensure that it is fully seated.
9. Turn F1 sprag assembly over again and install the F1 sprag inner race with the "square cut" pocket facing up, as shown in Figure 111.

Note: With the F1 sprag sprag assembly in this position, sprag inner race will freewheel in a counter-clockwise direction.

10. Turn the F1 sprag assembly over once again, as shown in Figure 112, which is the direction it is installed into transmission.

Note: In this position sprag inner race should freewheel clockwise and "chamfered" pocket should be facing up.

11. Set the completed F1 sprag assembly aside for the final assembly process.

Component Rebuild Continued on Page 68

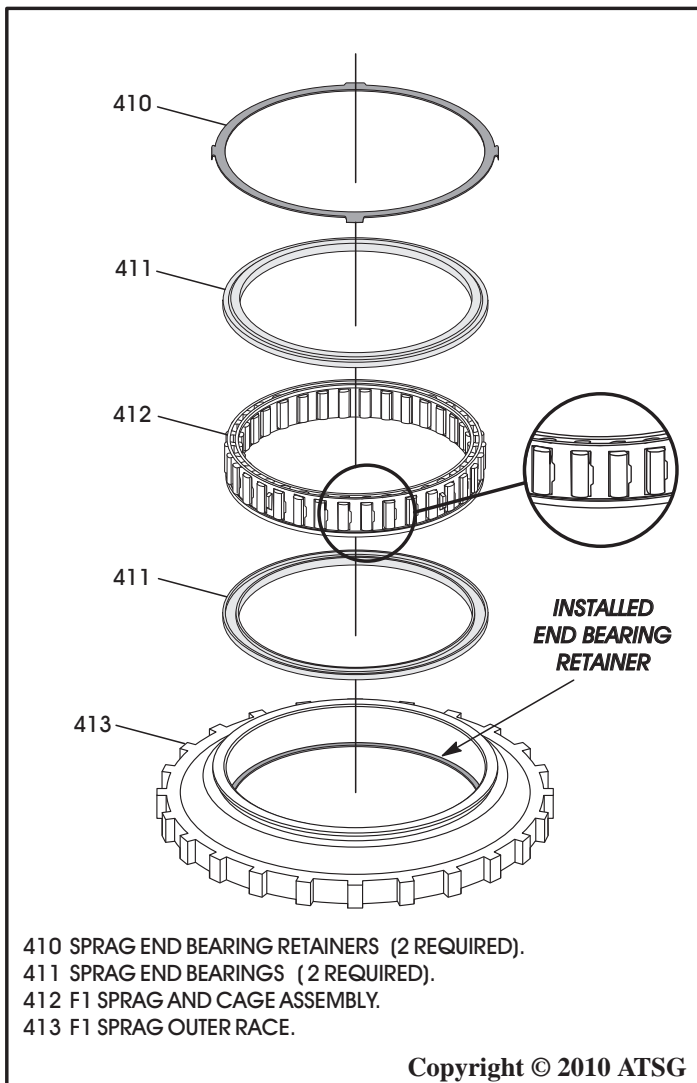

Figure 110

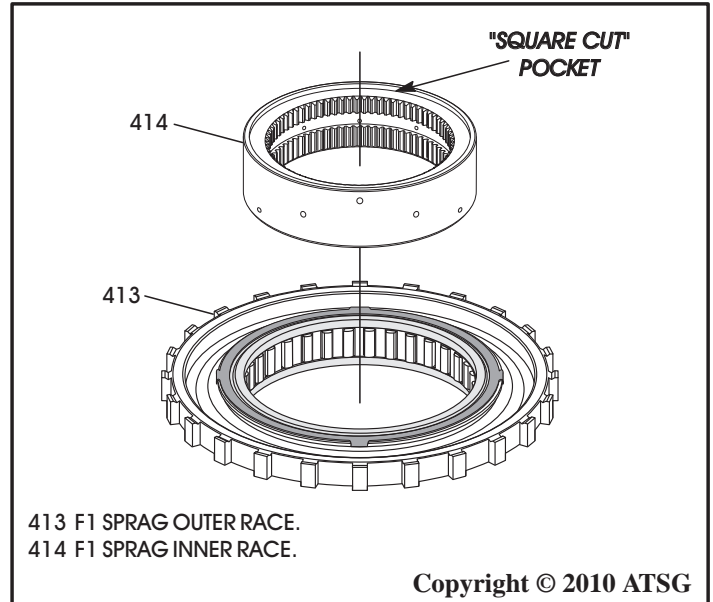

Figure 111

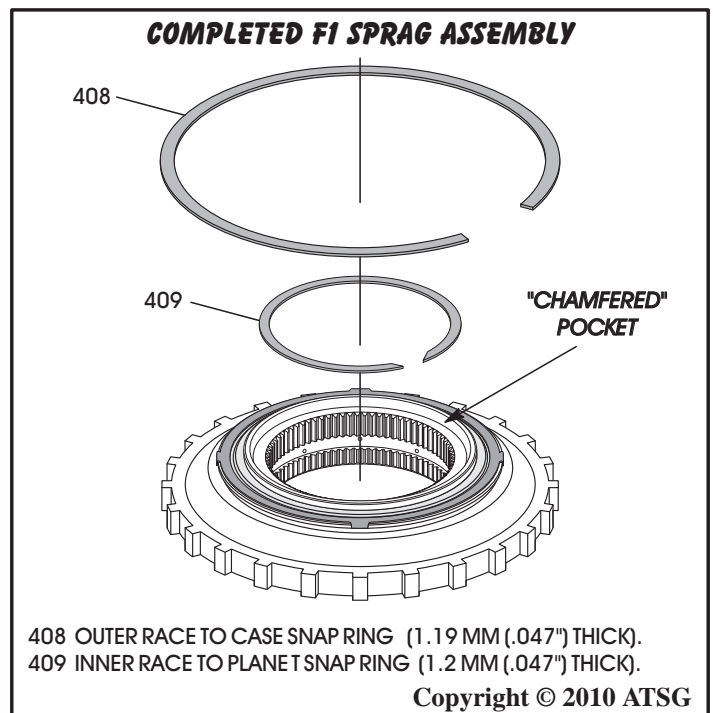
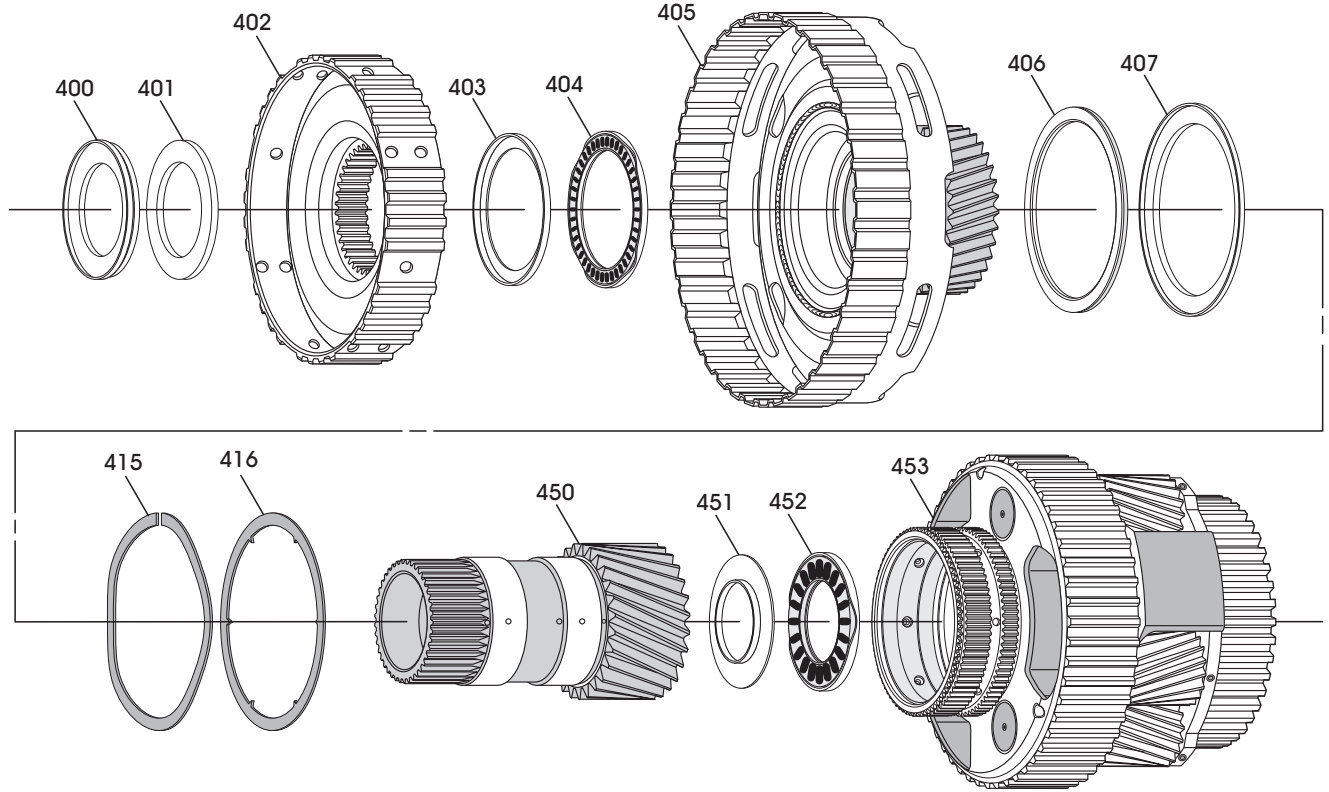

Figure 112

WWW.ALL-TRANS.BY

REAR GEAR TRAIN AND ASSOCIATED PARTS, EXPLODED VIEW



- 400 NUMBER 7 THRUST BEARING.
- 401 NUMBER 7 THRUST BEARING RACE.
- 402 K1 CLUTCH HUB.
- 403 NUMBER 8 THRUST BEARING RACE.
- 404 NUMBER 8 THRUST BEARING.
- 405 LARGE REAR SUN GEAR AND SHELL ASSEMBLY.
- 406 NUMBER 9 THRUST BEARING.

- 407 NUMBER 9 THRUST BEARING RACE.
- 415 SPLIT "WAVE" SPRING.
- 416 SPRAG INNER RACE SPACER (6 TEETH ON INSIDE DIAMETER).
- 450 SMALL REAR SUN GEAR AND SHAFT ASSEMBLY.
- 451 NUMBER 10 THRUST BEARING RACE.
- 452 NUMBER 10 THRUST BEARING.
- 453 REAR PLANETARY CARRIER ASSEMBLY.

Copyright © 2010 ATSG

Figure 113

COMPONENT REBUILD (CONT'D) SUN GEARS AND THRUST BEARINGS

1. Exploded view of sun gears and associated parts is shown in Figure 113.
2. Clean all sun gear parts thoroughly and dry with compressed air.
3. Inspect all sun gear parts thoroughly for any wear and/or damage, replace as necessary.
4. Install the number 10 thrust bearing race onto the small sun gear, as shown in Figure 114, and retain with small amount of Trans-Jel®.
5. Set the small sun gear assembly aside for the final assembly process (See Figure 115).

Continued on Page 69

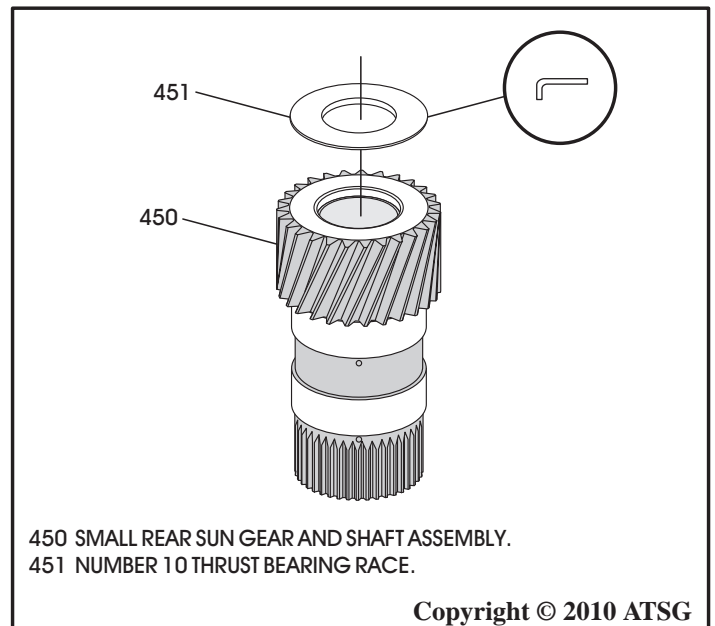

- 450 SMALL REAR SUN GEAR AND SHAFT ASSEMBLY.
- 451 NUMBER 10 THRUST BEARING RACE.

Copyright © 2010 ATSG

Figure 114

COMPONENT REBUILD (CONT'D)
SUN GEARS AND THRUST BEARINGS (CONT'D)

WWW.ALL-TRANS.BY

6. Install number 9 thrust bearing on sun gear shell, with needles facing up, as shown in Figure 116, retain with Trans-Jel®.

Note: Number 9 thrust bearing race installs on rear carrier during final assembly process.

7. Turn sun gear shell over and install number 8 thrust bearing into sun gear shell with needles facing up, as shown in Figure 117, retain with Trans-Jel®.

Note: Number 8 thrust bearing race installs on K1 clutch hub (See Figure 119).

8. Set the completed large sun gear and shell aside for the final assembly process (See Figure 118).

Continued on Page 70

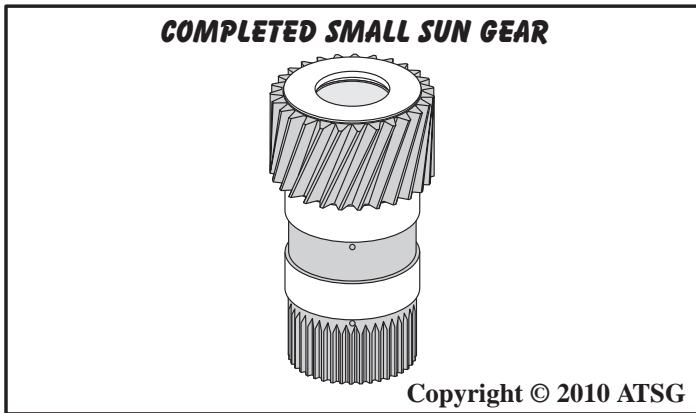

Figure 115

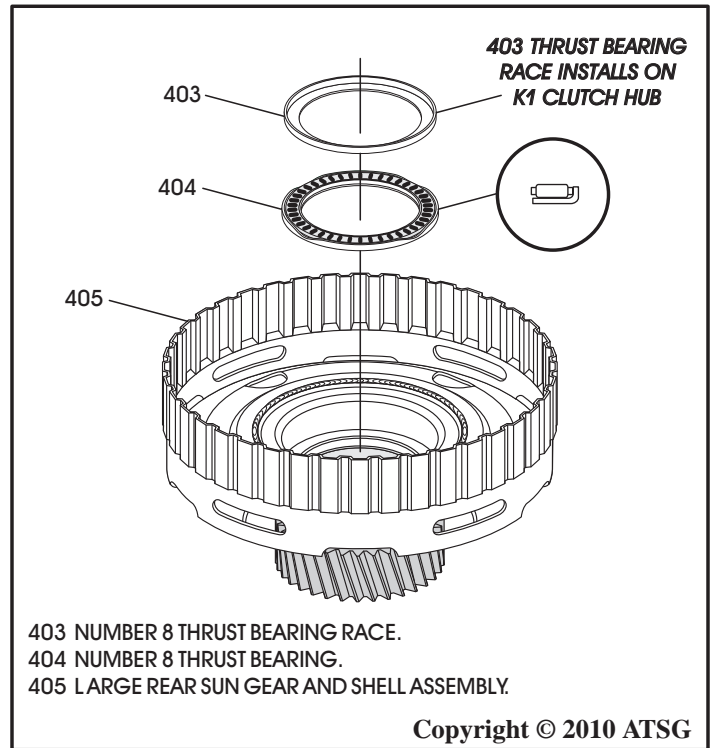

Figure 117

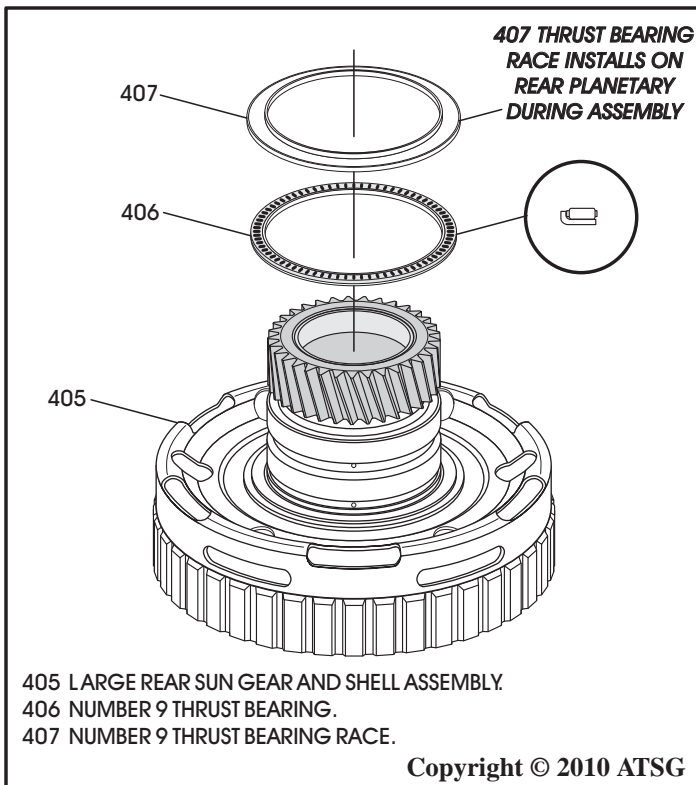

Figure 116

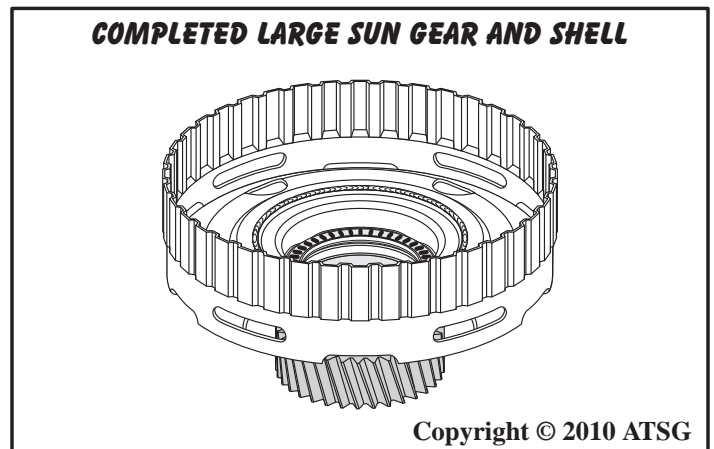

Figure 118

WWW.ALL-TRANS.COM

COMPONENT REBUILD (CONT'D) SUN GEARS AND THRUST BEARINGS (CONT'D)

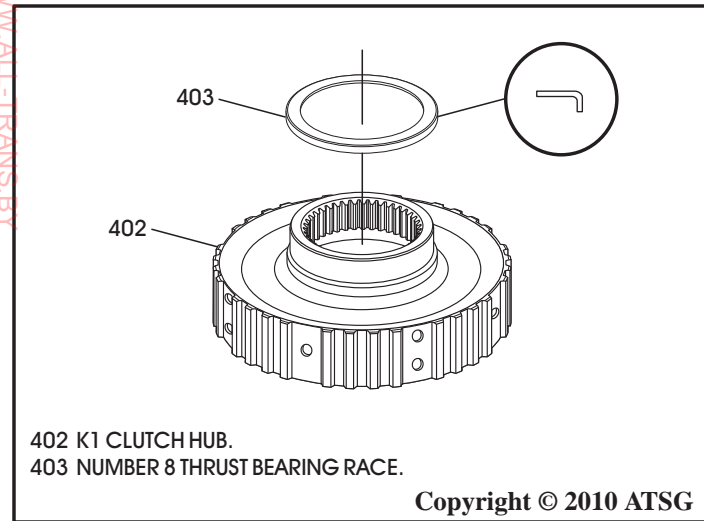

Figure 119

9. Install number 8 thrust bearing race on the back side of K1 clutch hub, as shown in Figure 119, and retain with Trans-Jel®.
 10. Turn K1 clutch hub over and install number 7 thrust bearing race, as shown in Figure 120, and retain with Trans-Jel®.
- Note: Number 7 thrust bearing is installed on back side of K1 clutch housing.*
11. Set the K1 clutch hub assembly aside for the final assembly process (See Figure 121).

**Component Rebuild
Continued on Page 71**

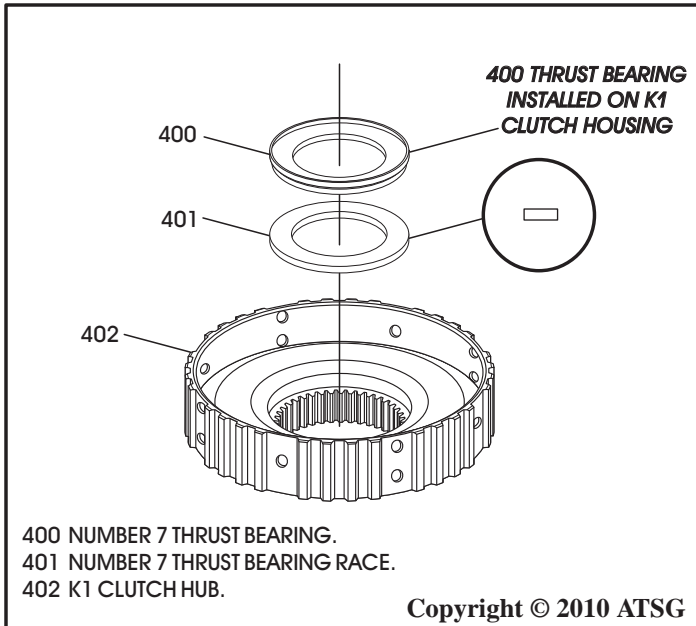

Figure 120

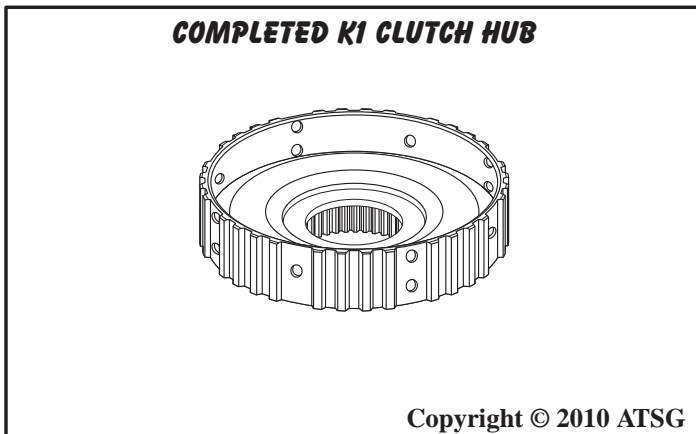

Figure 121

COMPONENT REBUILD (CONT'D)

K1 CLUTCH HOUSING ASSEMBLY

1. Disassemble the K1 clutch housing assembly using Figure 122 as a guide.
2. Clean all K1 clutch housing parts thoroughly and dry with compressed air.
3. Inspect all K1 clutch housing parts thoroughly for any wear and/or damage, and replace parts as necessary.

CAUTION: At the time of this printing, there are not any new "hard parts" available from the manufacturer for this unit. The only source will be used aftermarket suppliers.

Continued on Page 72

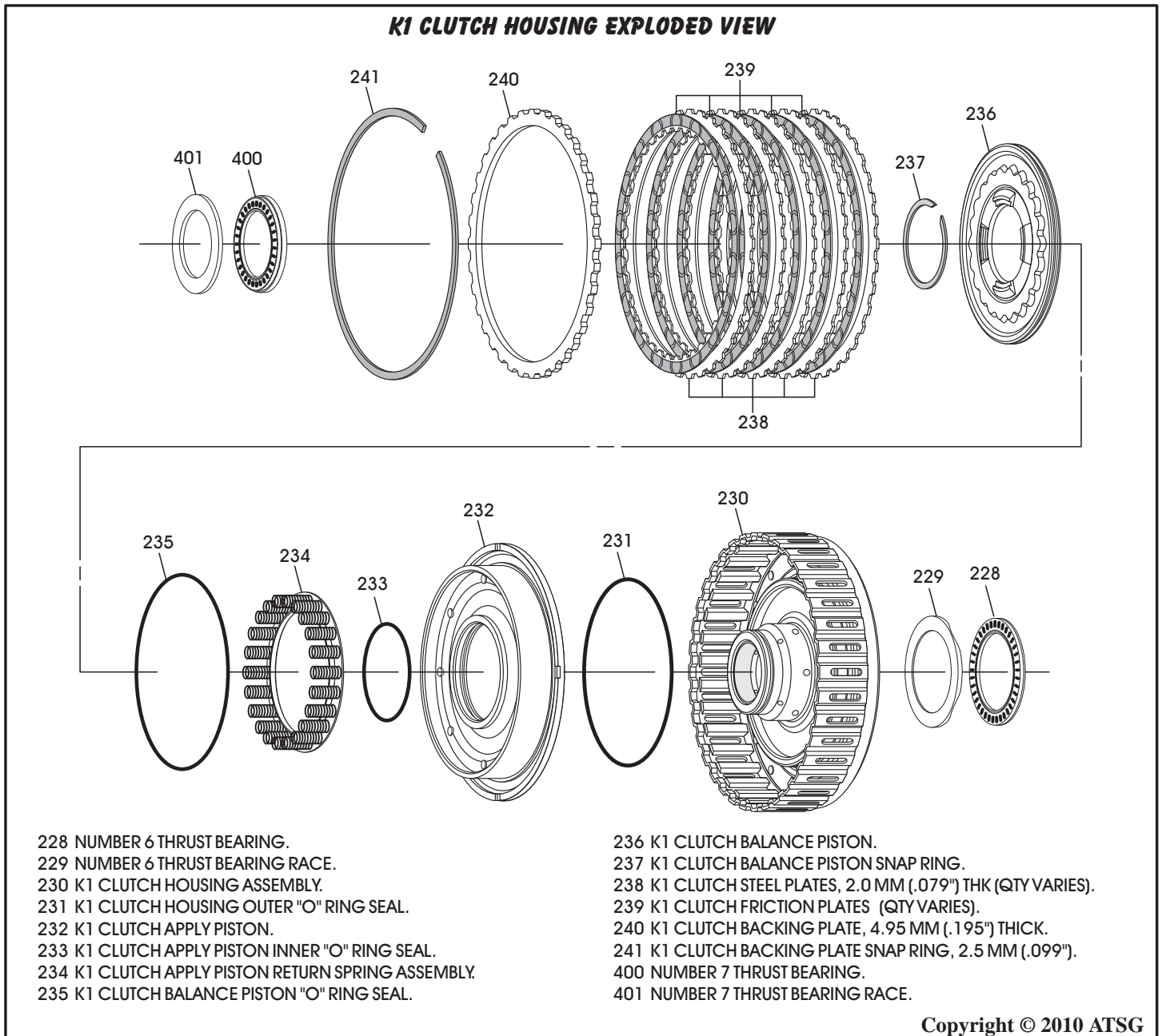

Figure 122

COMPONENT REBUILD (CONT'D)

K1 CLUTCH HOUSING ASSEMBLY (CONT'D)

4. Install new inner "O" ring seal into the groove of the K1 clutch apply piston, as shown in Figure 123, and lube with Trans-Jel®.
5. Install new "O" ring seal into groove of the K1 clutch balance piston, as shown in Figure 124, and lube with small amount of Trans-Jel®.
6. Turn the balance piston over and install the return spring assembly into the holes of the balance piston, as shown in Figure 125.

Note: Retain with a liberal amount of Trans-Jel®.

7. Install new outer K1 clutch piston "O" ring seal into groove of the K1 clutch housing, as shown in Figure 126, and lube with a small amount of Trans-Jel®.

Continued on Page 73

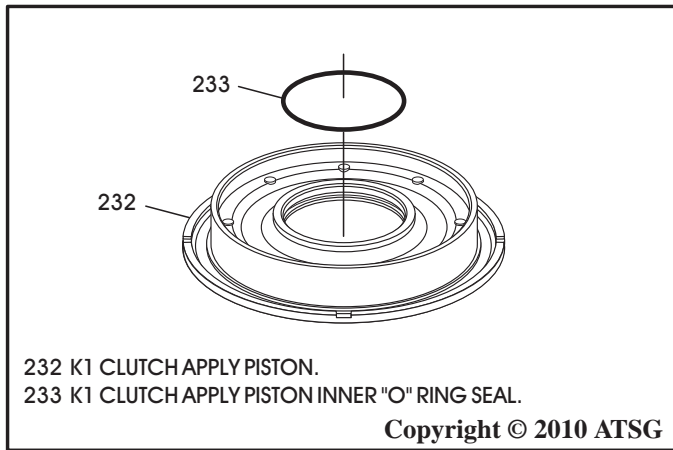

Figure 123

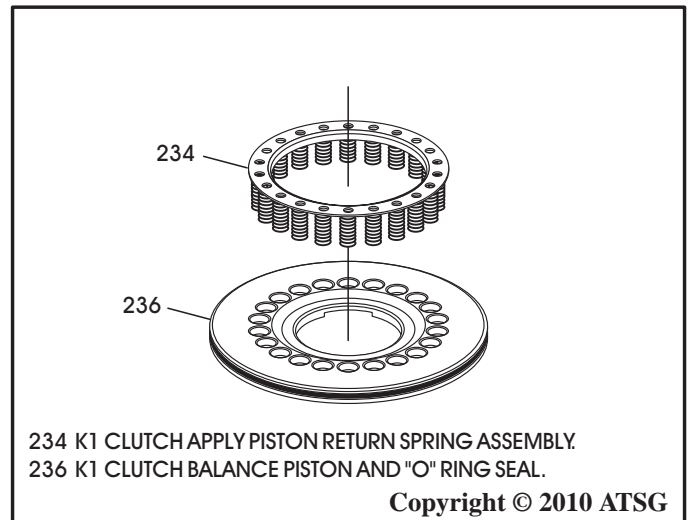

Figure 125

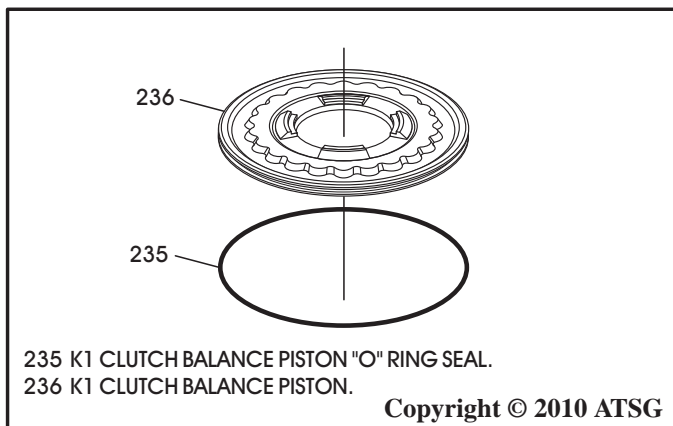

Figure 124

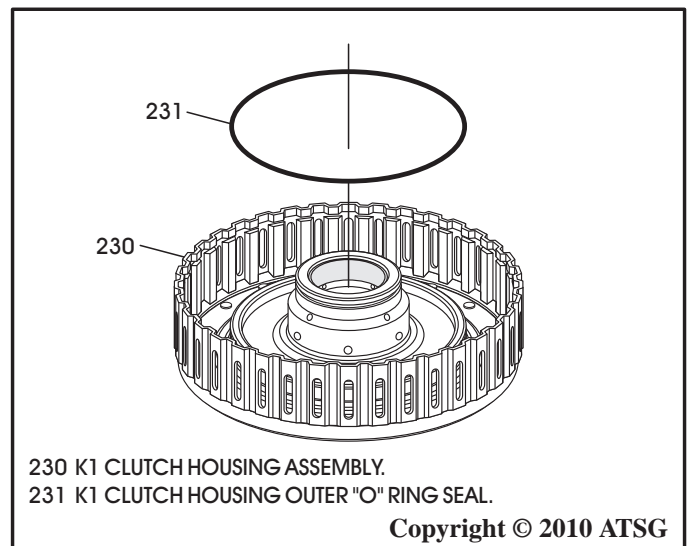

Figure 126

COMPONENT REBUILD (CONT'D)

K1 CLUTCH HOUSING ASSEMBLY (CONT'D)

8. Install the completed K1 clutch apply piston in K1 clutch housing, as shown in Figure 127.
9. Install the completed K1 balance piston and return spring as an assembly, as shown in Figure 127.
10. Compress the balance piston and return spring and install the retaining snap ring, as shown in Figure 127.
11. Install the K1 clutch plates beginning with a steel plate and alternating with the friction plates, as shown in Figure 128, until you have the proper amount installed as quantity varies.
Note: All friction plates should be soaked in proper fluid for 30 minutes before installing.
12. Install the K1 clutch backing plate, as shown in Figure 128, with the rounded edge facing the friction plate (See Figure 128).
13. Install the K1 clutch backing plate snap ring, as shown in Figure 128.

Continued on Page 74

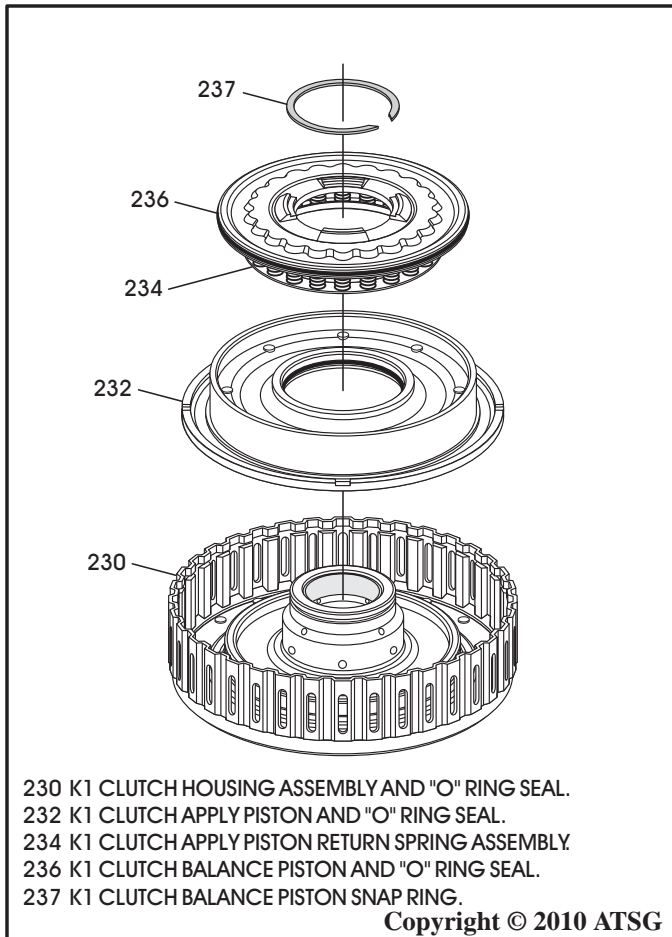

Figure 127

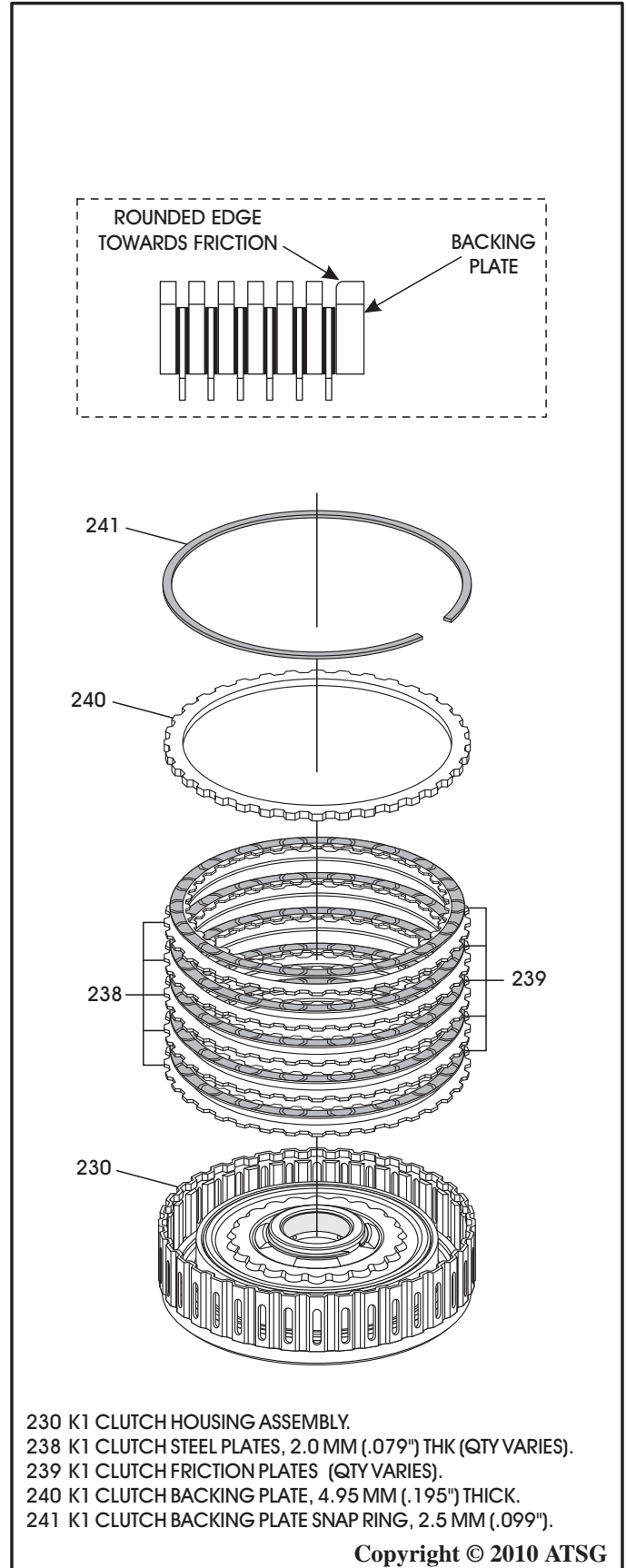

Figure 128

COMPONENT REBUILD (CONT'D)

K1 CLUTCH HOUSING ASSEMBLY (CONT'D)

14. Measure the K1 clutch clearance with a feeler gauge between the backing plate and snap ring, as shown in Figure 129.

Note: There are no factory clutch clearance specifications available, but the clearances were the "traditional" .010" per friction plate through-out this unit.

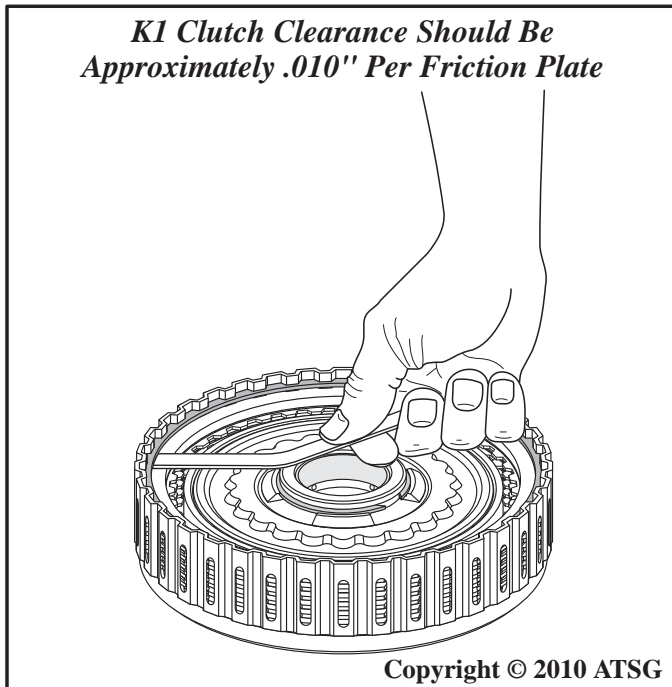

Figure 129

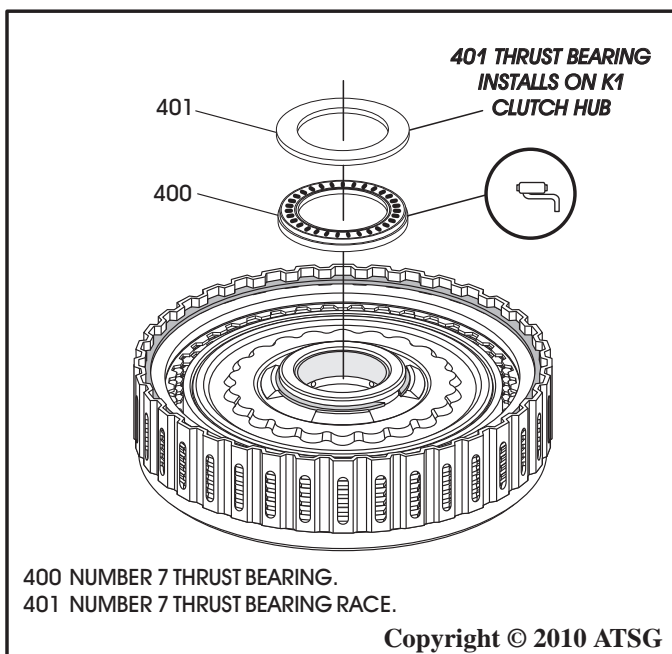

Figure 130

15. K1 clutch clearance should be approximately .010" per friction plate installed, as shown in Figure 129.

16. Install number 7 thrust bearing on K1 clutch housing, as shown in Figure 130, and retain with Trans-Jel®.

Note: Number 7 thrust bearing race installs K1 clutch hub.

17. Turn the K1 clutch housing over and install the number 6 thrust bearing race in the direction shown in Figure 131 and retain with a small amount of Trans-Jel®.

Note: Number 6 thrust bearing installs on back side of turbine shaft.

18. Set the completed K1 clutch housing aside for the final assembly process.

Component Rebuild Continued on Page 75

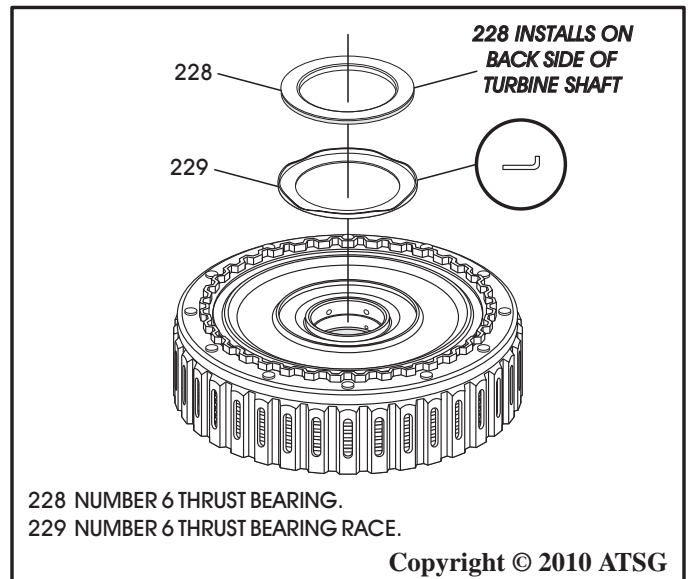

Figure 131

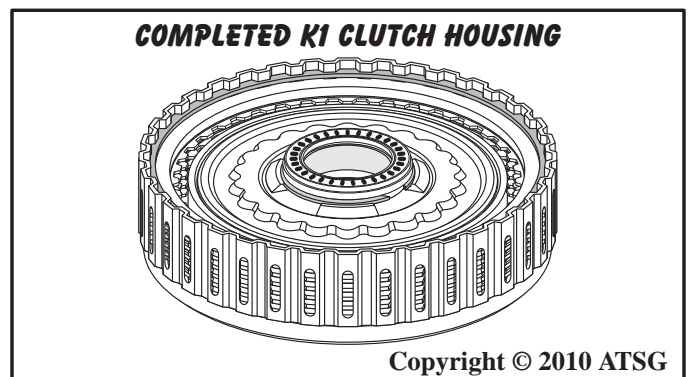

Figure 132

COMPONENT REBUILD (CONT'D)

K3 CLUTCH HOUSING ASSEMBLY

1. Disassemble the K3 clutch housing assembly using Figure 133 as a guide.
2. Clean all K3 clutch housing parts thoroughly and dry with compressed air.
3. Inspect all K3 clutch housing parts thoroughly for any wear and/or damage, and replace parts as necessary.

CAUTION: At the time of this printing, there are not any new "hard parts" available from the manufacturer for this unit. The only source will be used aftermarket suppliers.

Continued on Page 76

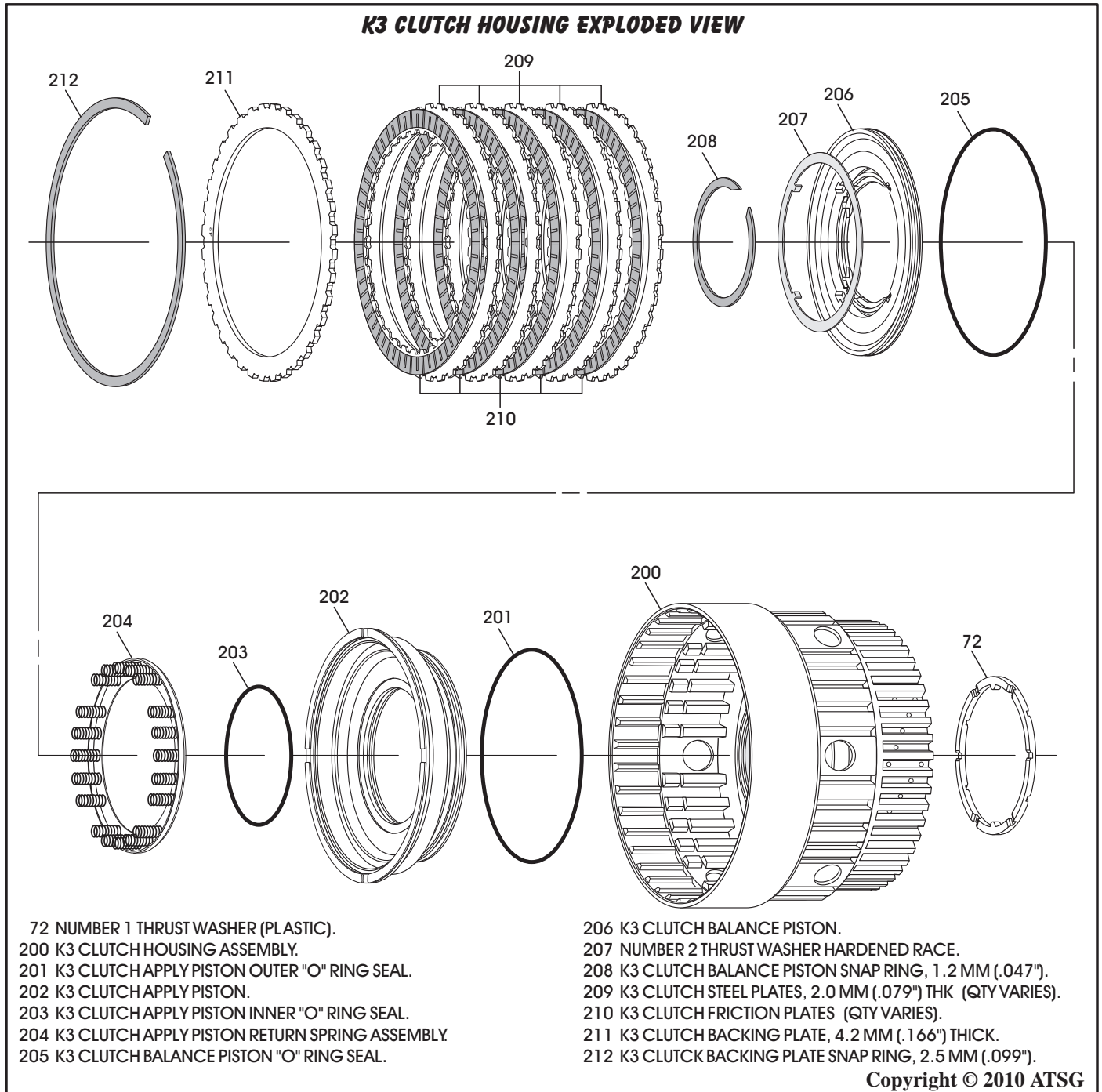

Figure 133

COMPONENT REBUILD (CONT'D)

K3 CLUTCH HOUSING (CONT'D)

4. Install new inner and outer "O" ring seals onto K3 clutch apply piston and lube with a small amount of Trans-Jel® (See Figure 134).
5. Install new "O" ring seal on K3 clutch balance piston, as shown in Figure 135, and lube with a small amount of Trans-Jel®.
6. Install the number 2 thrust washer race onto balance piston, as shown in Figure 135, and retain with Trans-Jel®.

7. Install the apply piston return spring assembly to the bottom of balance piston, as shown in Figure 136, and retain with Trans-Jel®.
8. Lube the seal surfaces of K3 clutch housing and install completed K3 clutch apply piston, as shown in Figure 137.

Continued on Page 77

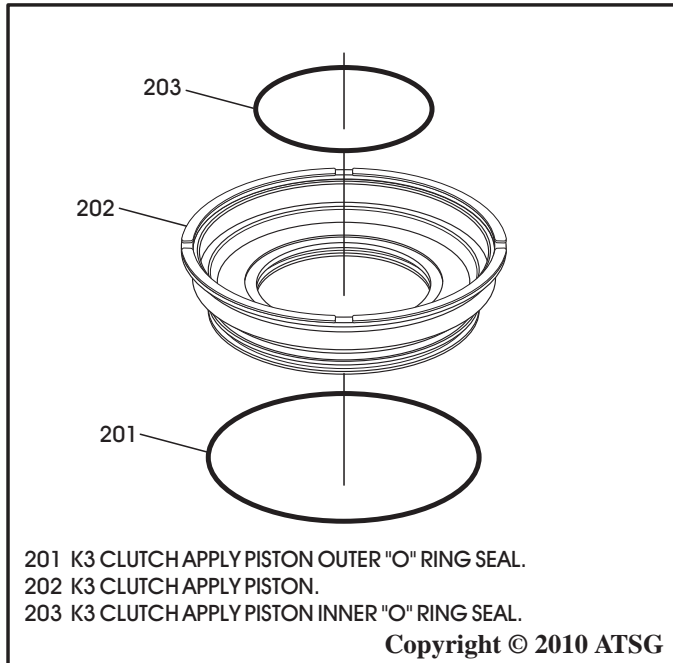

Figure 134

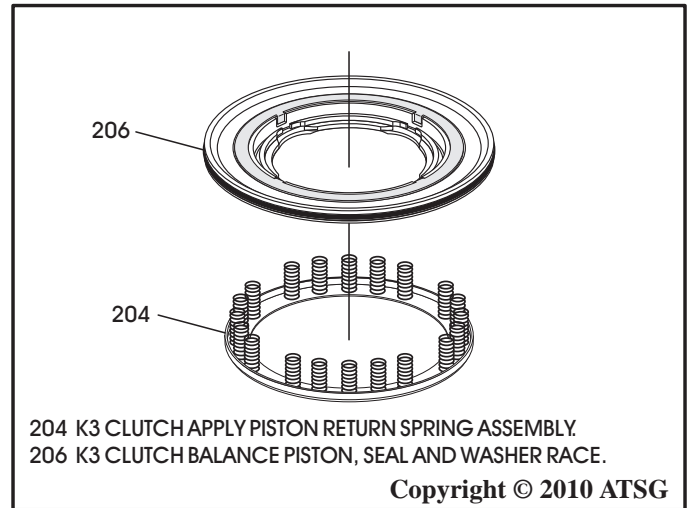

Figure 136

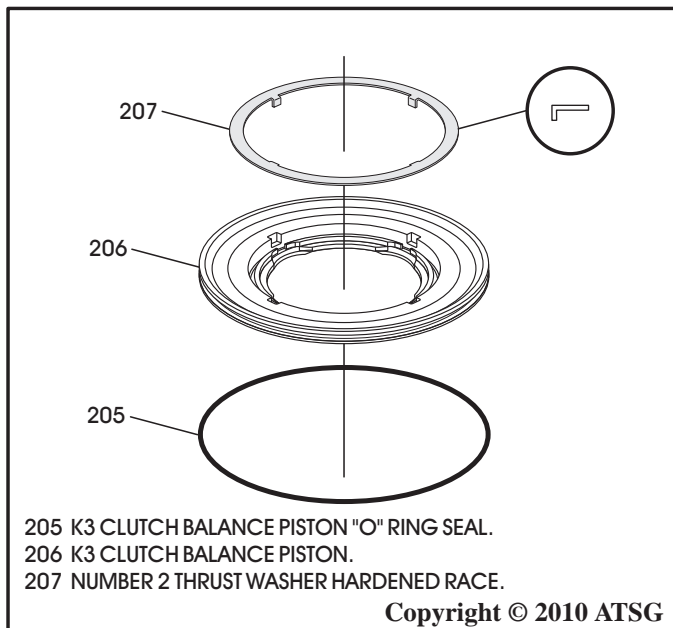

Figure 135

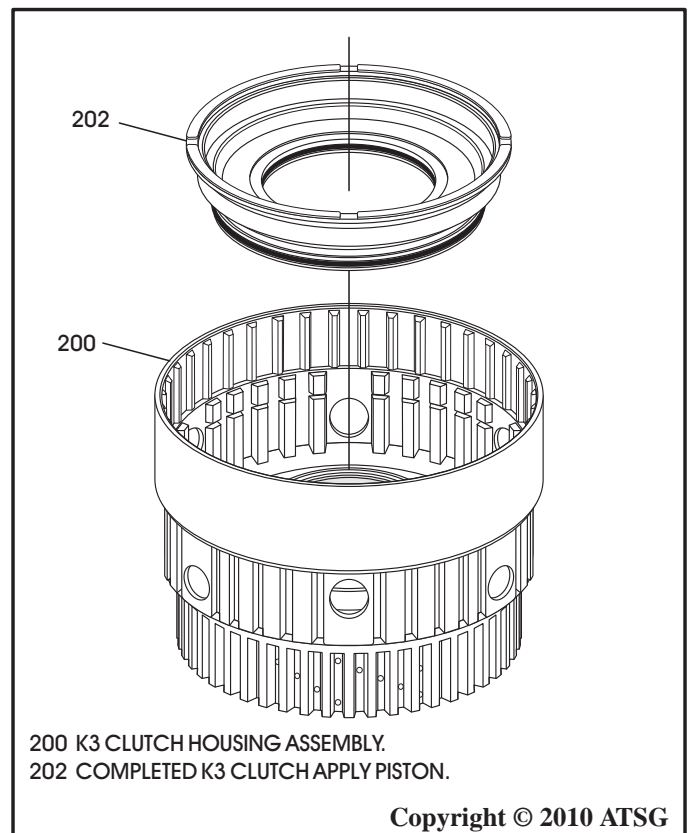

Figure 137

COMPONENT REBUILD (CONT'D)

K3 CLUTCH HOUSING (CONT'D)

9. Install the completed K3 balance piston and return spring as an assembly, as shown in Figure 138.
10. Compress the balance piston and return spring and install the retaining snap ring, as shown in Figure 138.
11. Install the K3 clutch plates beginning with a steel plate and alternating with the friction plates, as shown in Figure 139, until you have the proper amount installed as quantity varies.
Note: All friction plates should be soaked in proper fluid for 30 minutes before installing.
12. Install the K3 clutch backing plate, as shown in Figure 139, with the rounded edge facing the friction plate.
13. Install the K3 clutch backing plate snap ring, as shown in Figure 139.

Continued on Page 78

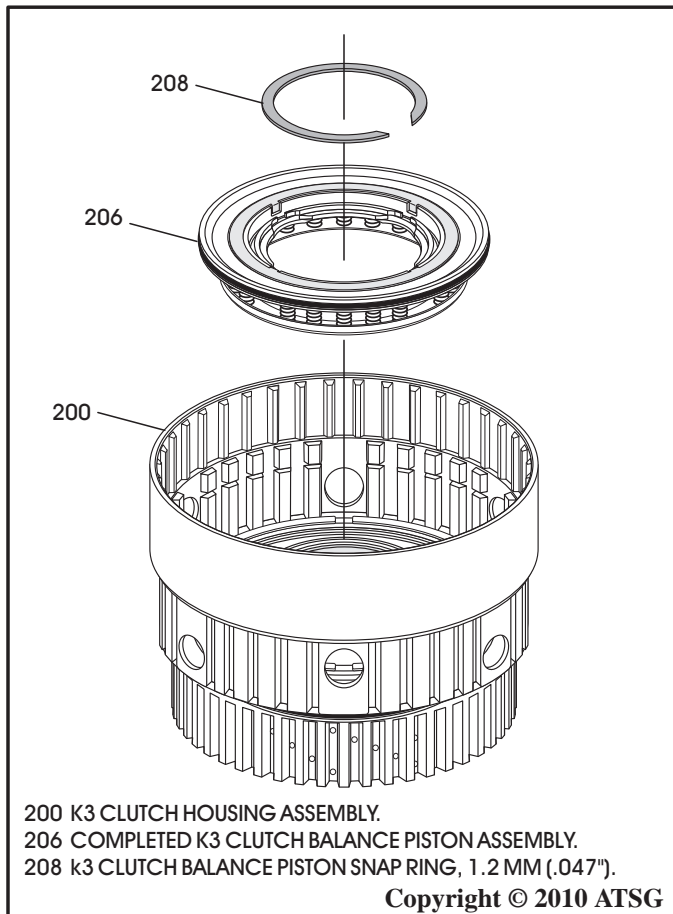

Figure 138

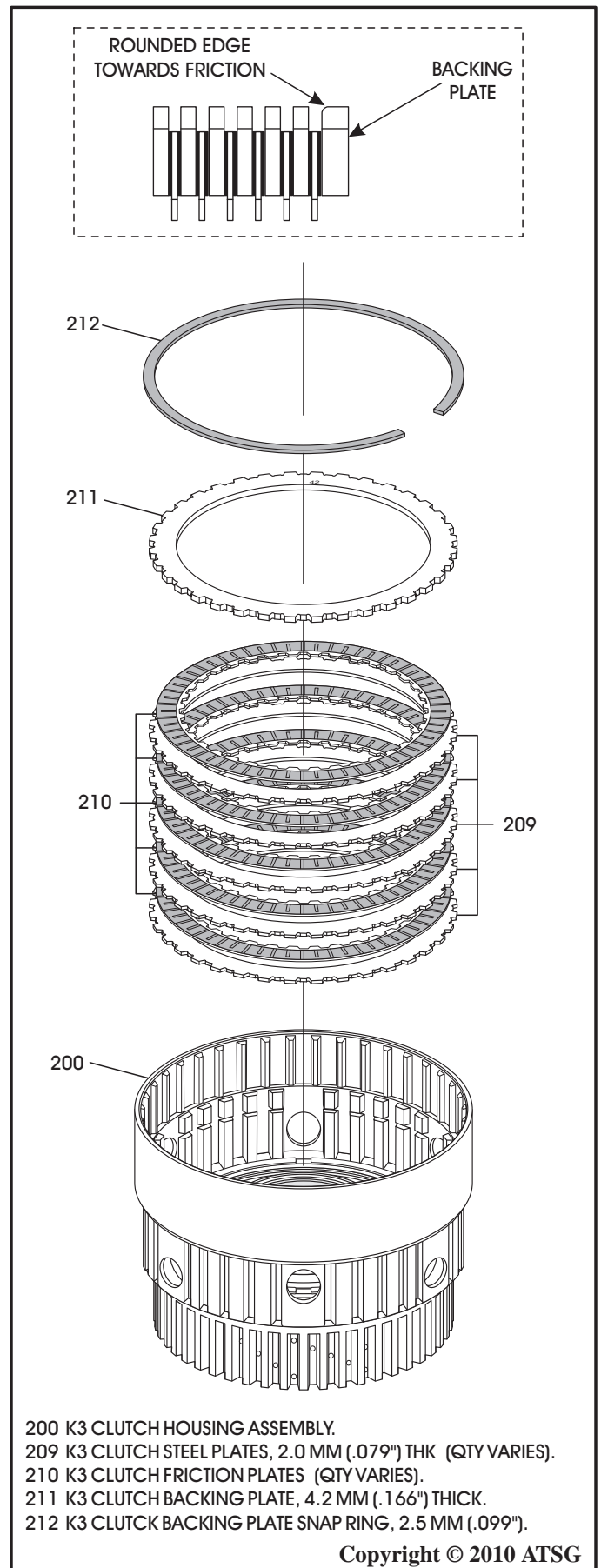
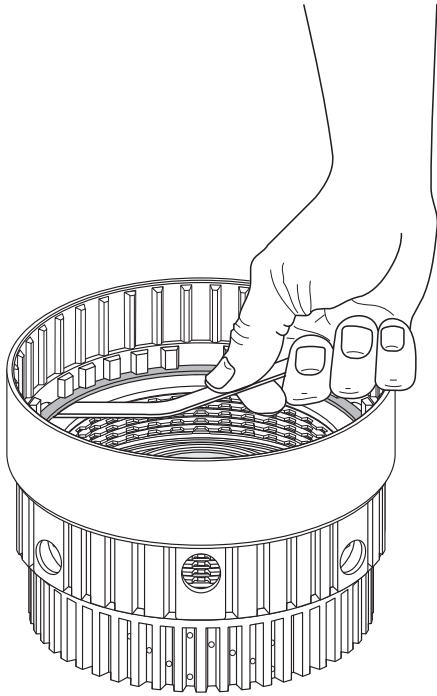

Figure 139

K3 Clutch Clearance Should Be Approximately .010" Per Friction Plate



Copyright © 2010 ATSG

Figure 140

COMPONENT REBUILD (CONT'D)

K3 CLUTCH HOUSING (CONT'D)

14. Measure the K3 clutch clearance with a feeler gauge between the backing plate and snap ring, as shown in Figure 140.

Note: There are no factory clutch clearance specifications available, but the clearances were the "traditional" .010" per friction plate through-out this unit.

15. K3 clutch clearance should be approximately .010" per friction plate installed, as shown in Figure 140.

16. Turn the K3 clutch housing over and install the number 1 thrust washer, engaging the tabs of the washer in housing, as shown in Figure 141.

17. Set the completed K3 clutch housing aside for the final assembly process (See Figure 142).

COMPLETED K3 CLUTCH HOUSING

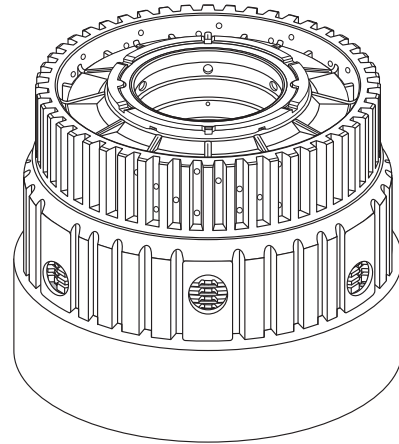

Copyright © 2010 ATSG

Figure 142

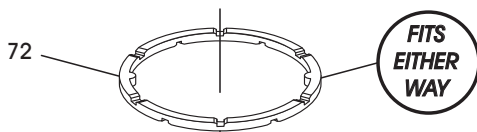

200

72 NUMBER 1 THRUST WASHER (PLASTIC).
200 K3 CLUTCH HOUSING ASSEMBLY.

Copyright © 2010 ATSG

Figure 141

CAUTION!

The next 2 components in "Component Rebuild" section have changes in the components, that are not interchangeable, and related to whether you have a "2-Port" or a "3-Port" torque converter. This requires an understanding of how each of these converters operate hydraulically and the description begins on Page 79, along with the dimensional differences in the affected parts.

**Component Rebuild Section
Continues on Page 82**

TORQUE CONVERTER DIFFERENCES

There are two different types of torque converters used in the "09D" transmission that changes some of the internal parts. One is a "2 Port" design and the other is a "3 Port" design, and refers to the number of fluid passages needed to function properly.

TCC "2 PORT" HYDRAULIC OPERATION

The "2 Port" Torque Converter functions like the traditional lock-up converter and has a single floating clutch plate.

Figure 143 below illustrates how the clutch and damper are riveted to the converter turbine. Converter fill fluid is fed into the release circuit from the TCC valve in the valve body through the center of the turbine shaft where it is routed between the converter cover and pressure plate. This fluid pressure keeps the converter clutch released and fills the converter. When the clutch is commanded on, fill fluid (release oil) is exhausted at the TCC apply valve and converter pressure applies the clutch against the converter cover.

Note: The Oil Pump, Turbine Shaft and Spacer Plate are unique to the 2 Port Converter. Refer to Figure 145 & 146 for dimensional differences. Refer to Page 124 for spacer plate differences and identification.

TCC "3 PORT" HYDRAULIC OPERATION

The "3 Port" Torque Converter is uniquely constructed in that the converter clutch apply circuit is independent to the converter in and out fluid. The converter may also contain either 1 or 2 friction plates depending on engine size.

Figure 144 below, illustrates how the converter clutch apply piston contours to the flywheel side of the torque converter cover. The friction plates lug to a hub splined to the turbine shaft while the steel plates lug to the converter cover. When the clutch is commanded on, apply fluid is fed through the center of the turbine shaft and fills the area between the converter cover and piston. The piston applies the friction plates to the steel plates locking the turbine shaft to the cover.

Converter fill is fed into the converter between the converter hub that drives the pump gears and the stator shaft. The fluid's return path is between the stator shaft and turbine shaft.

Note: The Oil Pump, Turbine Shaft and Spacer Plate are unique to the 3 Port Converter. Refer to Figure 145 & 146 for dimensional differences. Refer to Page 124 for spacer plate differences and identification.

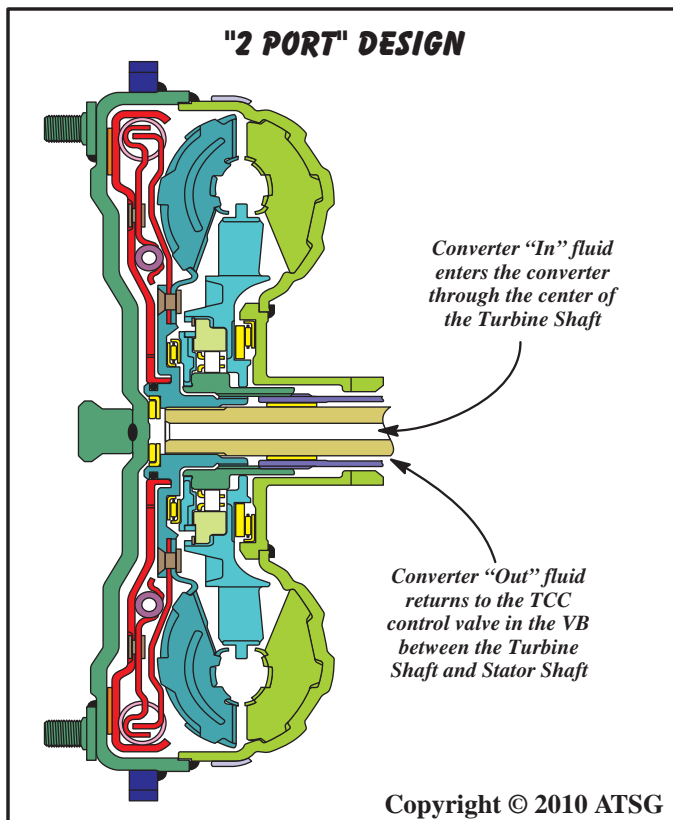

Figure 143

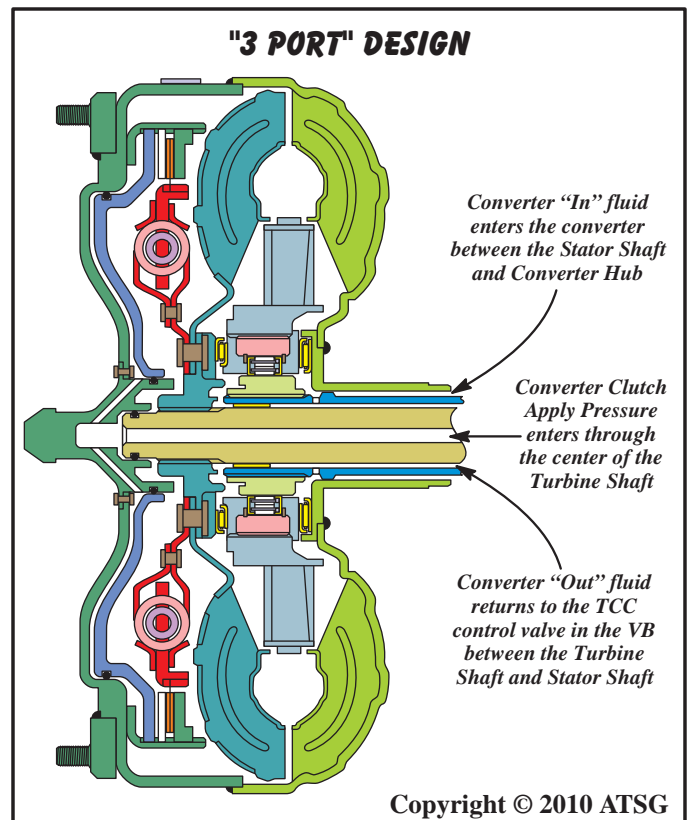

Figure 144

OIL PUMP ASSEMBLY AND TURBINE SHAFT DIFFERENCES

Oil Pump Body

The oil pump body for the 2-port converter is equipped with a caged needle bearing to support the torque converter and retained with a snap ring, as shown in Figure 145. The 3-port design is equipped with the traditional bushing, and is also shown in Figure 145. Notice also that the bore diameters are different between the two.

The easiest means of visual identification is caged needle bearing, or bushing.

Note: The oil pump bodies will not interchange.

Oil Pump Cover (Stator)

The passages in the oil pump cover (stator) are different between the 2-Port version and the 3-Port version. The oil pump cover for the 2-port converter is equipped with a much shorter stator shaft than the 3-port design and has a smaller diameter spline area on the stator shaft splines, as shown in Figure 145. Notice also the holes below the spline area on the 3-port design stator shaft, which is the easiest means of visual identification.

Note: The oil pump covers will not interchange.

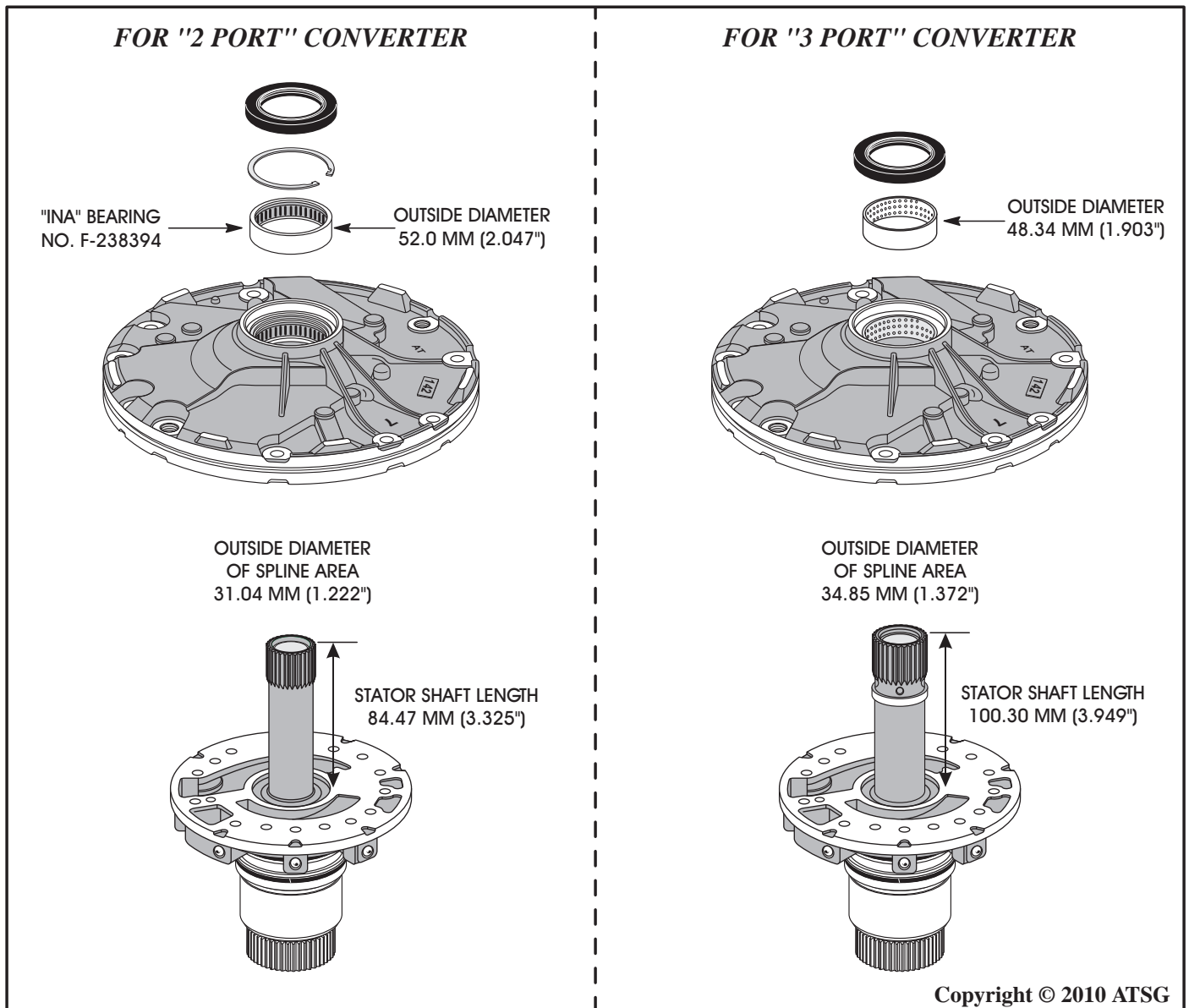

Figure 145

OIL PUMP ASSEMBLY AND TURBINE SHAFT DIFFERENCES

Turbine Shaft

There are many dimensional differences in length and diameters between the two turbine shafts, as shown in Figure 146. The easiest means of visual identification is the "2-port" design turbine shaft is equipped with 3 sealing rings with no "O" ring on pilot, and the "3-port" design turbine shaft is equipped with 4 sealing rings and an "O" ring on the pilot, as shown in Figure 146.

Now you know the differences between the two different design "2-Port" and "3-Port" torque converters and related parts.

**Component Rebuild
Continued on Page 82**

Note: Turbine shafts will not interchange.

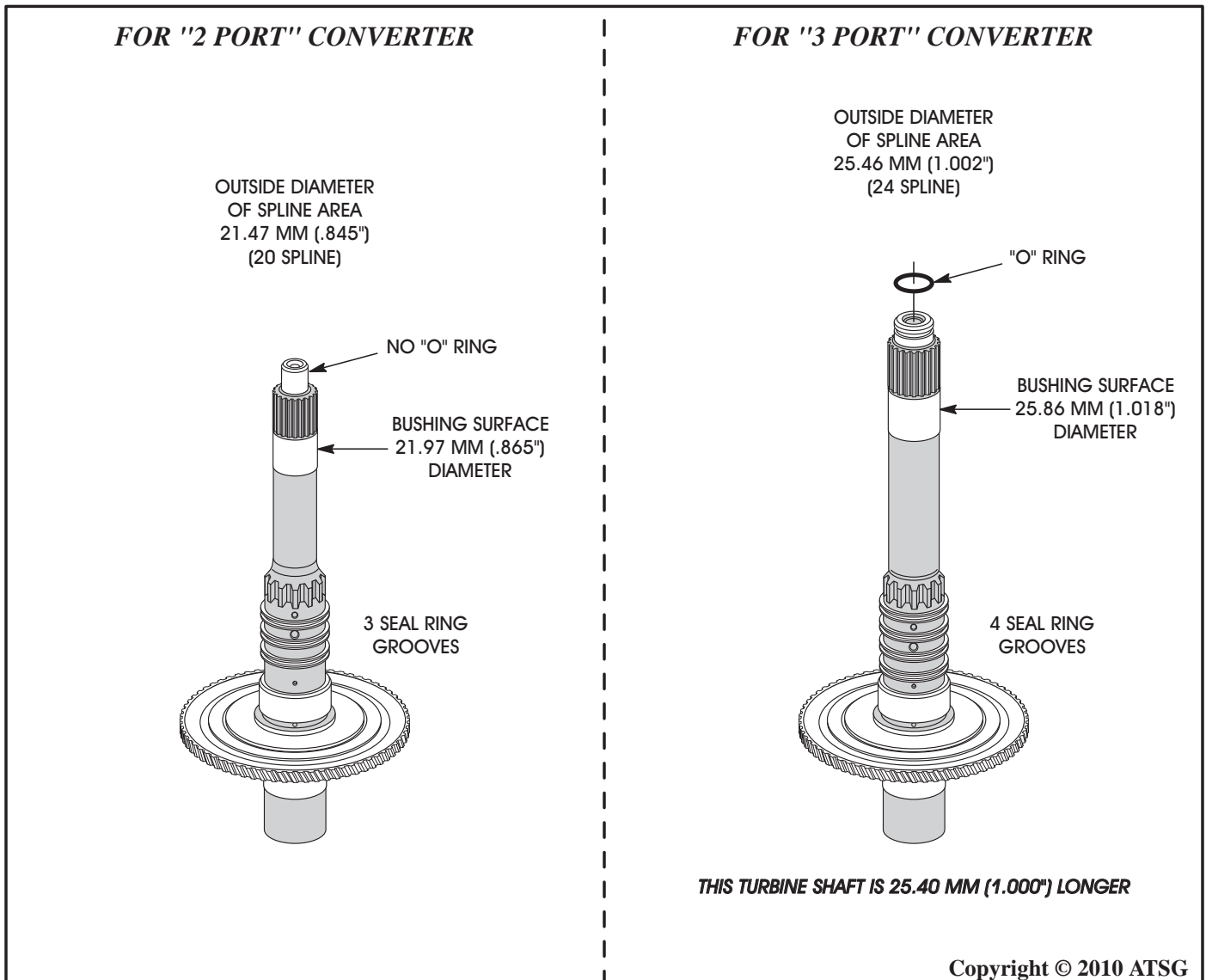

Figure 146

COMPONENT REBUILD (CONT'D)

FRONT PLANETARY ASSEMBLY

1. Disassemble front planetary assembly using Figure 147 as a guide.
Note: It is necessary to remove the ring gear and inspect for damaged splines.
2. Clean all front planetary parts thoroughly and dry with compressed air.

3. Inspect all front planetary parts thoroughly for any wear and/or damage, replace as necessary.
Caution: At the time of this printing, there are not any new "hard parts" available from the manufacturer for this unit.

Continued on Page 83

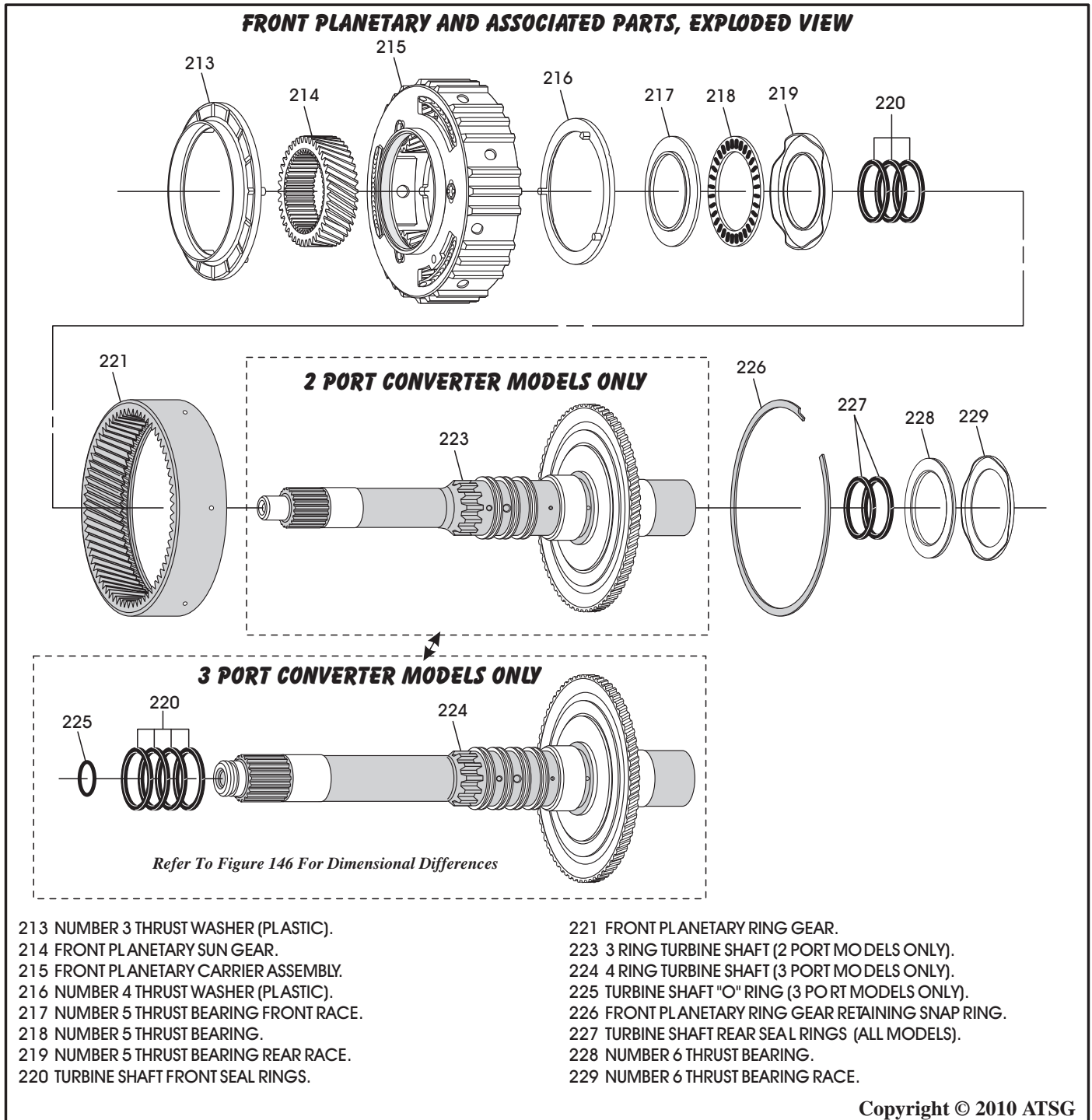

Figure 147

COMPONENT REBUILD (CONT'D)

FRONT PLANETARY ASSEMBLY (CONT'D)

4. Install front planet ring gear on turbine shaft and secure with snap ring (See Figure 148).
5. Install required amount of turbine shaft sealing rings on turbine shaft, as shown in Figure 148.
Note: The "O" ring on the turbine shaft pilot will be installed during final assembly.

6. Turn the assembly over and install number 6 thrust bearing, the with needles facing up, as shown in Figure 149.
Note: Number 6 thrust bearing race installs on to K1 clutch housing.
7. Install two more sealing rings on back side of turbine shaft, as shown in Figure 149.
Note: Ensure that ring gear snap ring is fully seated.

Continued on Page 84

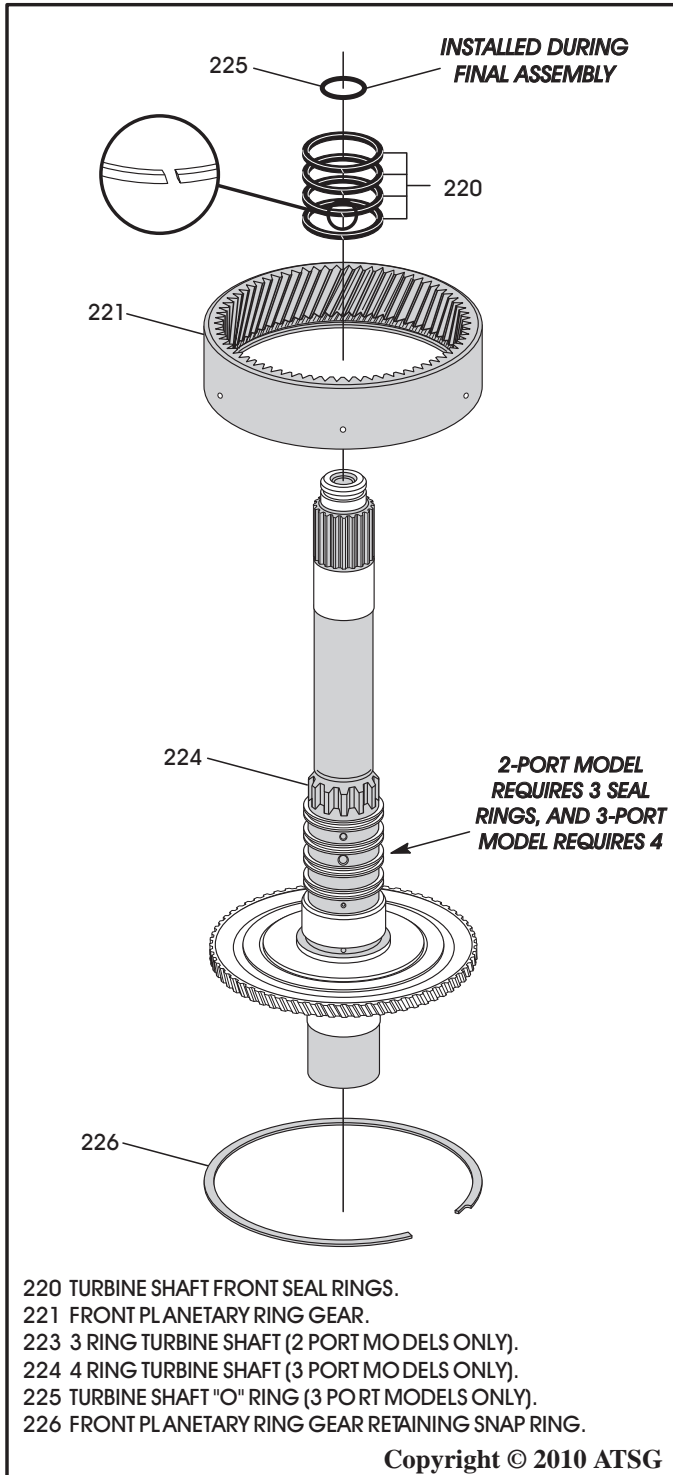

Figure 148

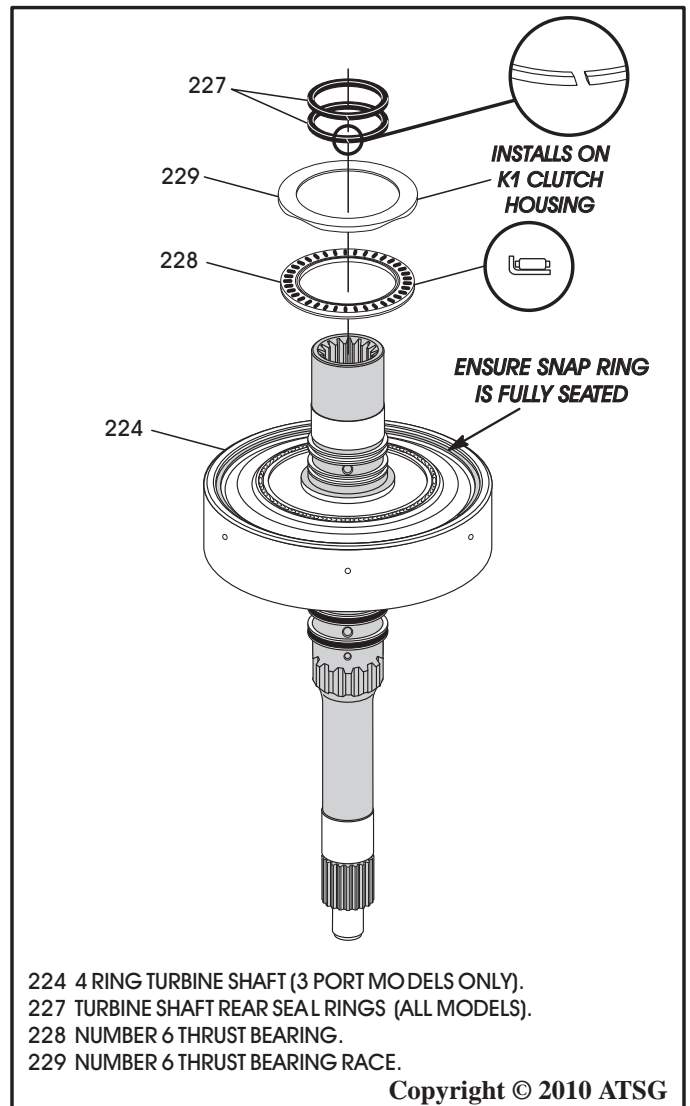

Figure 149

FRONT PLANETARY ASSEMBLY (CONT'D)

8. Install number 4 (white plastic) thrust washer on back side of the front planetary carrier, as shown in Figure 151.

9. Install number 5 thrust bearing rear race, the number 5 thrust bearing and number 5 thrust bearing front race, as shown in Figure 150.
10. Install the completed front planetary carrier, as shown in Figure 150, by rotating into position.
11. Install the front sun gear into the carrier, as shown in Figure 150, by rotating into position.
12. Install number 3 (white plastic) thrust washer, as shown in Figure 150.
13. Set the completed front planetary aside for the final assembly process (See Figure 152).

Component Rebuild Continued on Page 86

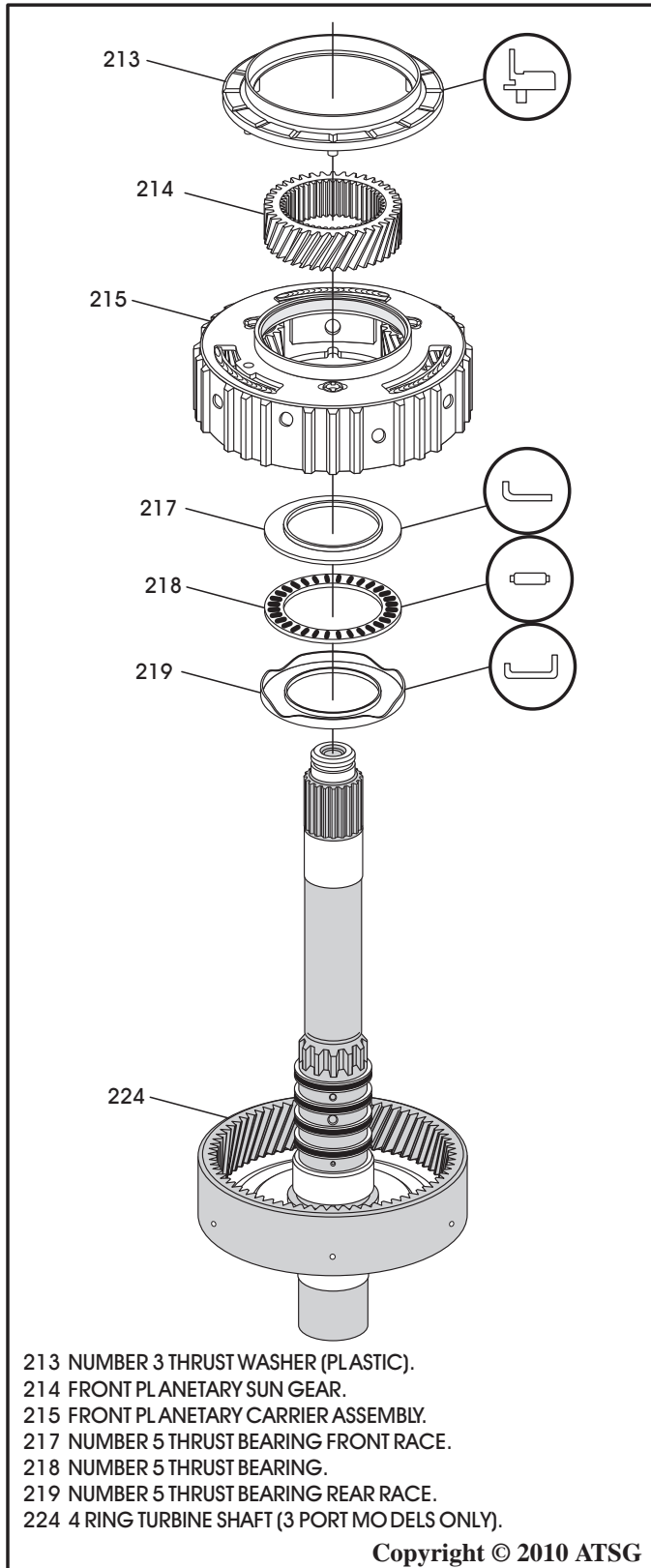

Figure 150

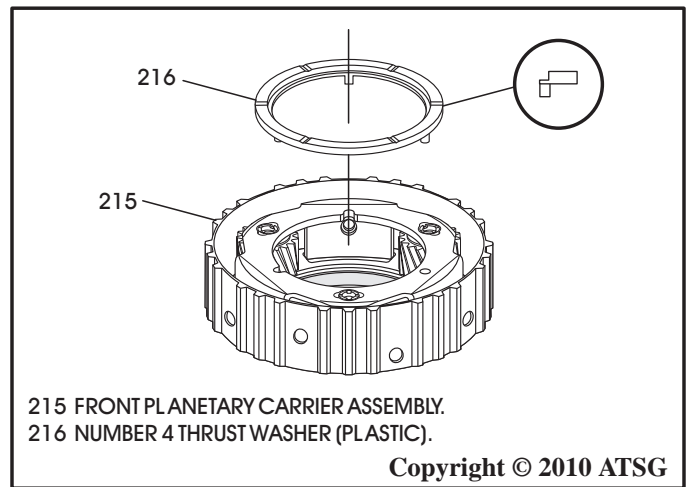

Figure 151

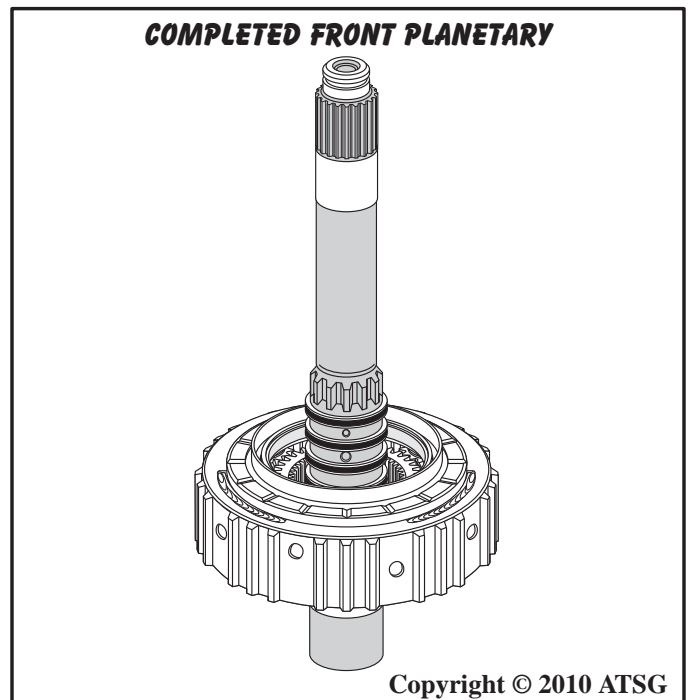
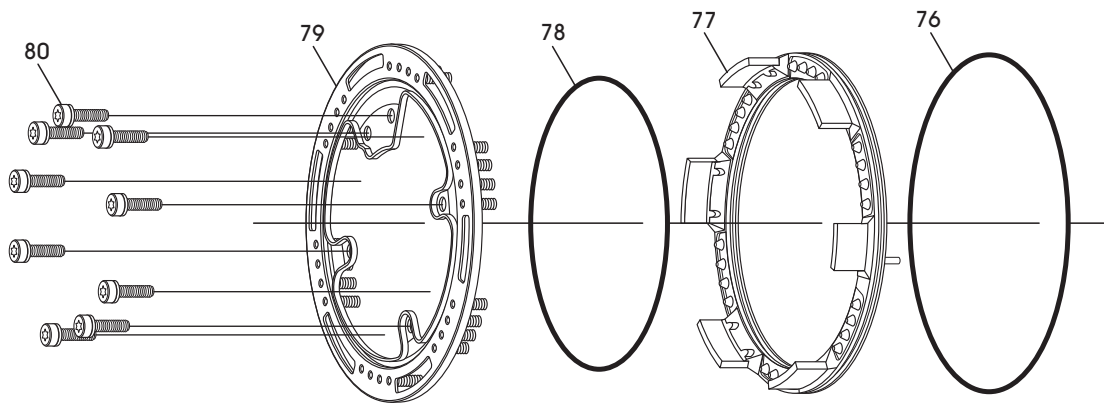
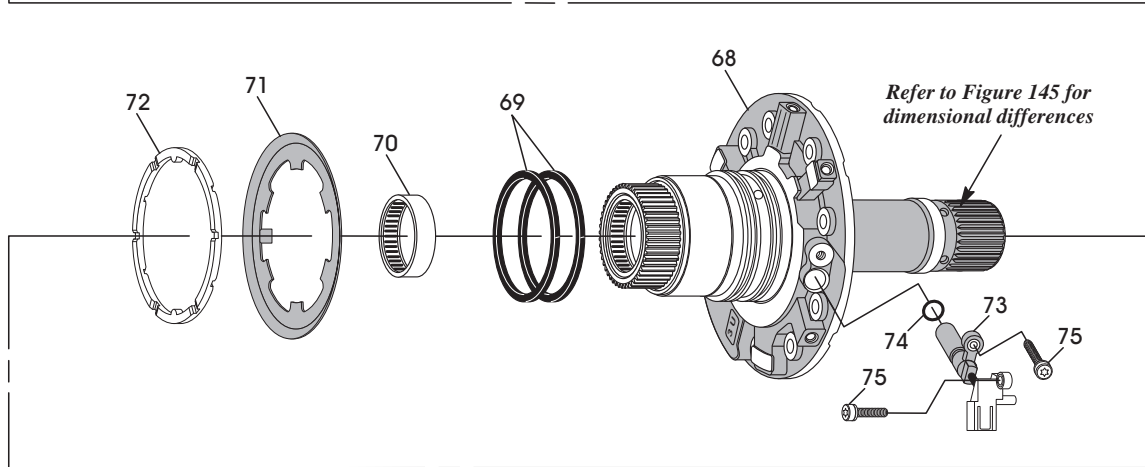
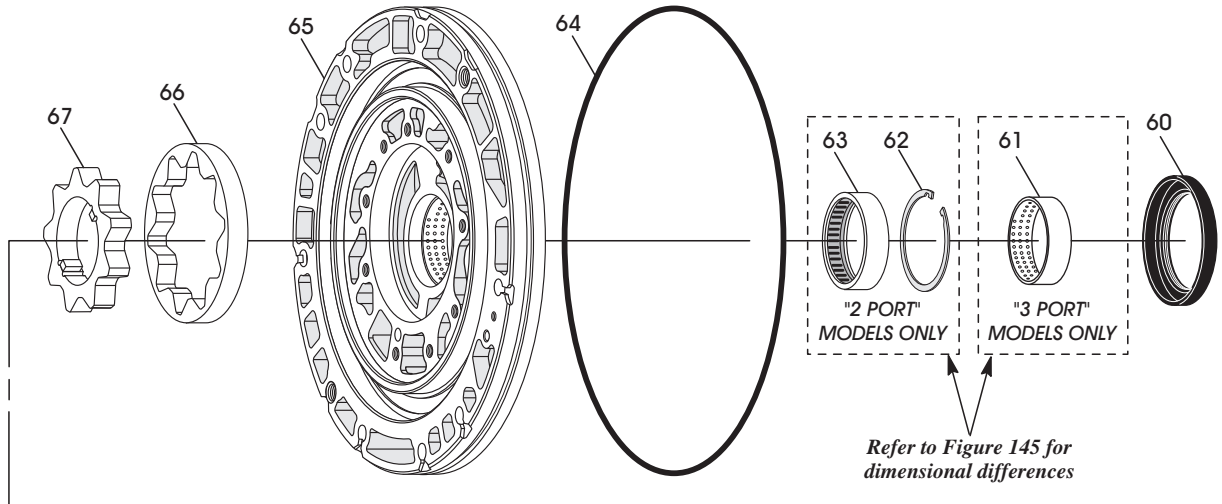

Figure 152

OIL PUMP AND ASSOCIATED PARTS, EXPLODED VIEW



- | | |
|---|--|
| <p>60 OIL PUMP CONVERTER HUB SEAL.
 61 OIL PUMP CONVERTER BUS HING (3 PORT ONLY).
 62 OIL PUMP CAGED BEARING SNAP RING (2 PORT ONLY).
 63 OIL PUMP CAGED BEARING (2 PORT ONLY).
 64 OIL PUMP TO CASE "O" RING SEAL.
 65 OIL PUMP BODY.
 66 OIL PUMP OUTER GEROTOR.
 67 OIL PUMP INNER GEROTOR.
 68 OIL PUMP COVER AND STATOR SHAFT ASSEMBLY.
 69 OIL PUMP COVER, K3 SEAL RINGS (2 REQUIRED).
 70 OIL PUMP COVER CAGED NEEDLE BEARING.</p> | <p>71 NUMBER 1 THRUST WASHER STEEL RACE.
 72 NUMBER 1 THRUST WASHER (PLASTIC).
 73 INPUT SHAFT SPEED SENSOR (G182).
 74 INPUT SHAFT SPEED SENSOR "O" RING SEAL.
 75 ISS SENSOR AND ISS CO NN. BOLTS, 1.6 MM (.630") (2 REQ).
 76 B1 CLUTCH PISTON OUTER "O" RING SEAL.
 77 B1 CLUTCH PISTON.
 78 B1 CLUTCH PISTON INNER "O" RING SEAL.
 79 B1 CLUTCH PISTON RETURN SPRING ASSEMBLY.
 80 PUMP COVER RETAINING BOLTS, 17 MM (.670") (9 REQ).</p> |
|---|--|

Copyright © 2010 ATSG

Figure 153

COMPONENT REBUILD (CONT'D)

OIL PUMP ASSEMBLY

1. Disassemble the oil pump assembly using Figure 153 as a guide.
Note: Pump gerotors should be marked on face, with black "Sharpie", to be reinstalled in the same direction as all gerotors are not marked by factory.
2. Clean all oil pump parts thoroughly and dry with compressed air.
3. Inspect all oil pump assembly parts thoroughly for any wear and/or damage, and replace as necessary.
Caution: At the time of this printing there are not any new hard parts available from the manufacturer for this unit.

4. Again, as a precaution, we are showing you the difference in the oil pump parts between the "2-Port" and "3-Port" torque converters in Figure 154.
Note: Everything in the oil pump assembly is the same, except for what is illustrated in Figure 154.

Continued on Page 87

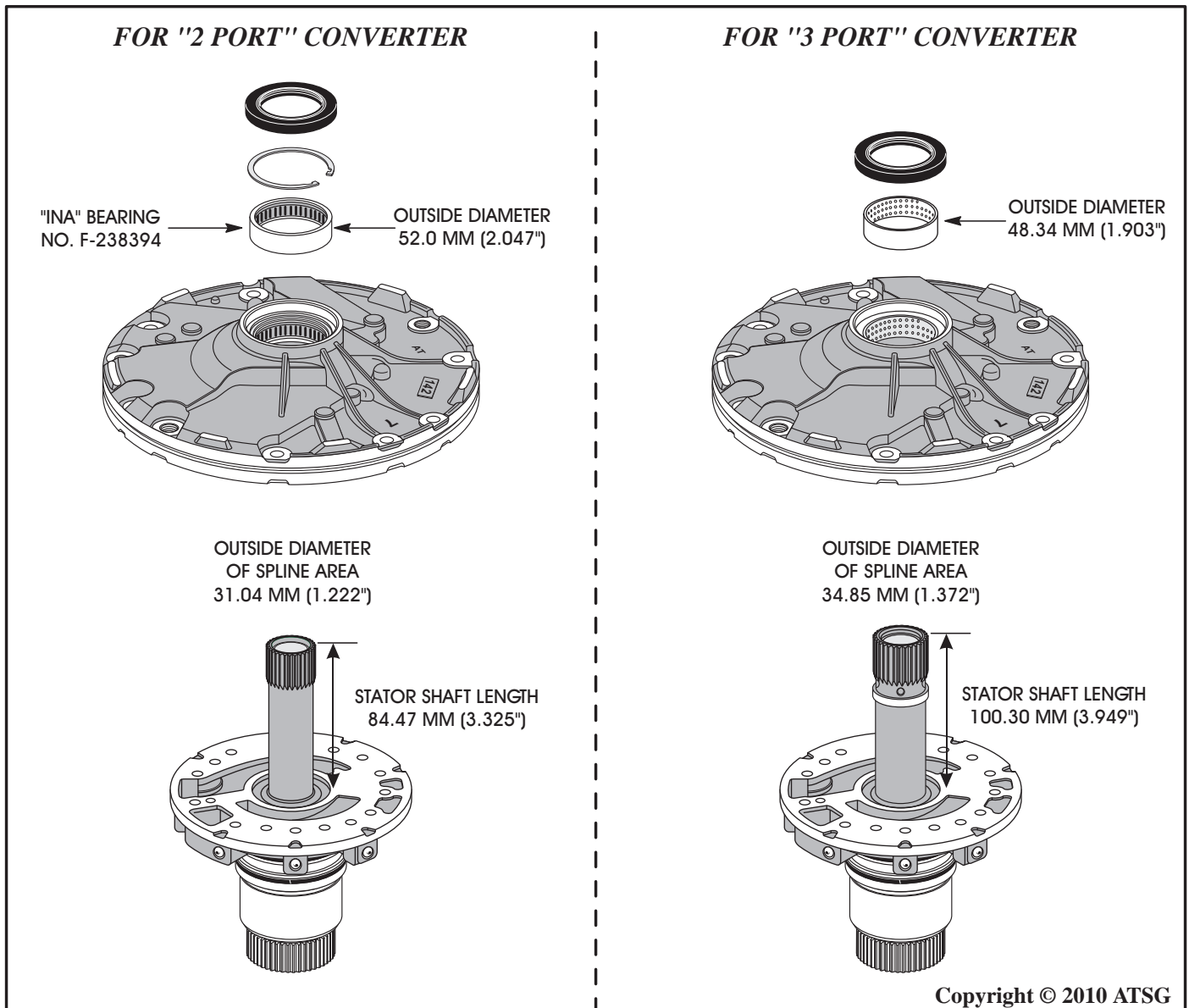

Copyright © 2010 ATSG

Figure 154

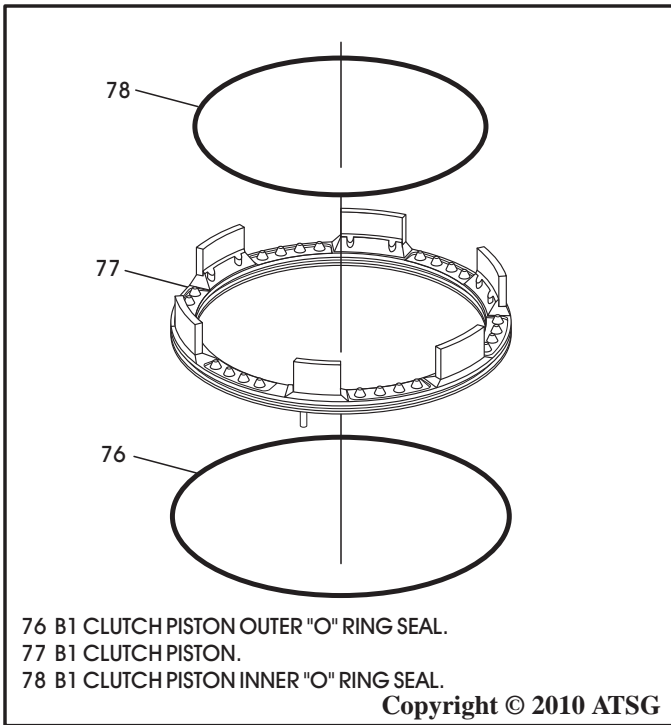

Figure 155

COMPONENT REBUILD (CONT'D) OIL PUMP ASSEMBLY (CONT'D)

5. Install the inner and outer "O" ring seals onto the B1 clutch piston, as shown in Figure 155, and lube with small amount of Trans-Jel®.
6. Install new caged needle bearing as needed with the numbers on bearing *facing up*, as shown in Figure 156 (2-Port models only). **Note: Bearing is not available from OEM, but may be available at local bearing house under INA number F-238394.**
7. Install new bushing in pump body as needed, as shown in Figure 157 (3-Port models only), using the proper driver.
8. Install new converter hub seal into pump body, as shown in Figure 156 and/or 157 using the proper seal driver.

Continued on Page 88

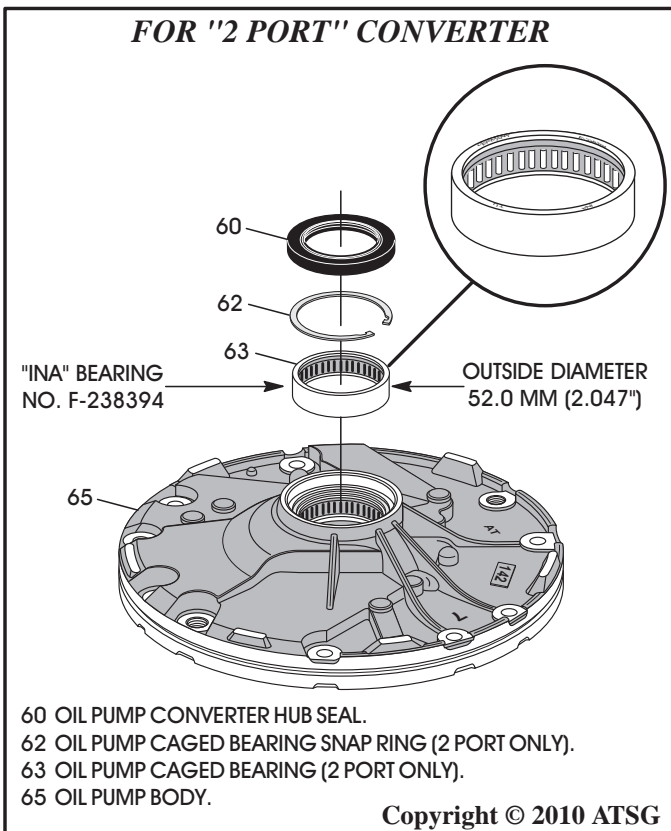

Figure 156

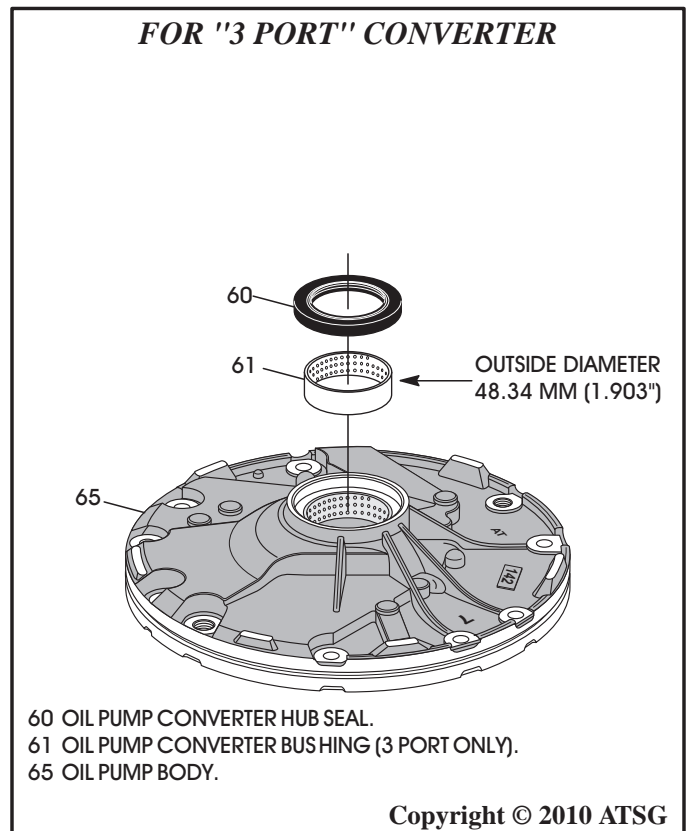

Figure 157

COMPONENT REBUILD (CONT'D)

OIL PUMP ASSEMBLY (CONT'D)

- Install the outer and inner gerotor into pump body, as shown in Figure 158, with marks facing up, *if they have marks*.
Note: They should go back in same direction as original placement.

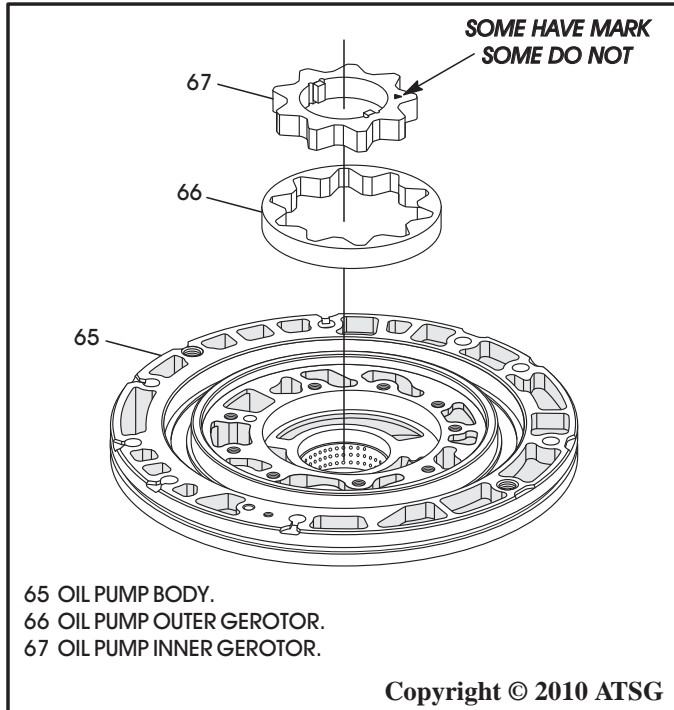

Figure 158

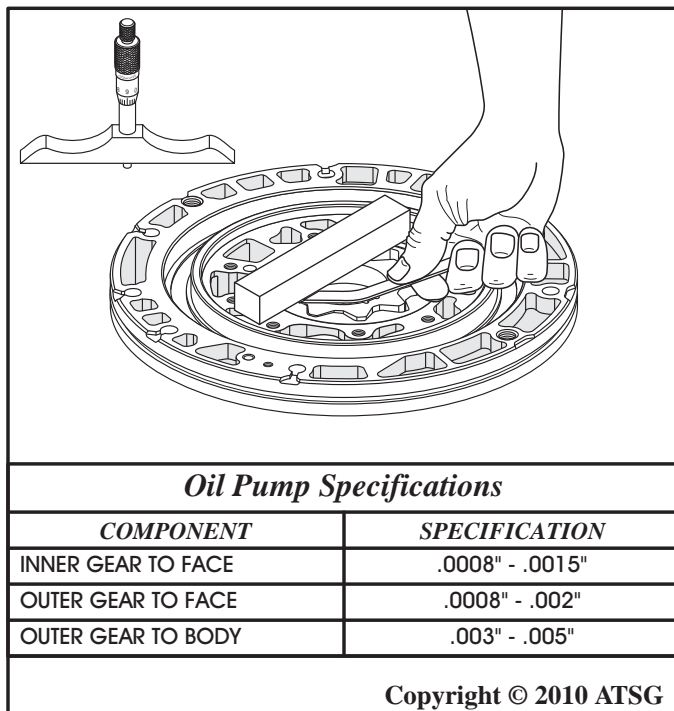

Figure 159

- Measure the gear to face clearance on both the inner and outer gerotor using a feeler gage or a depth micrometer, as shown in Figure 159.
Note: Pump specifications are in Figure 159.
- Lubricate the gerotors with small amount of proper transmission fluid.
- Install the pump cover into the pump body, as shown in Figure 160, using only four bolts in the locations shown and hand tighten only.
Note: The remaining 5 bolts also retain the B1 clutch return spring assembly.
- Install new oil pump body to case "O" ring seal, as shown in Figure 160.

Continued on Page 89

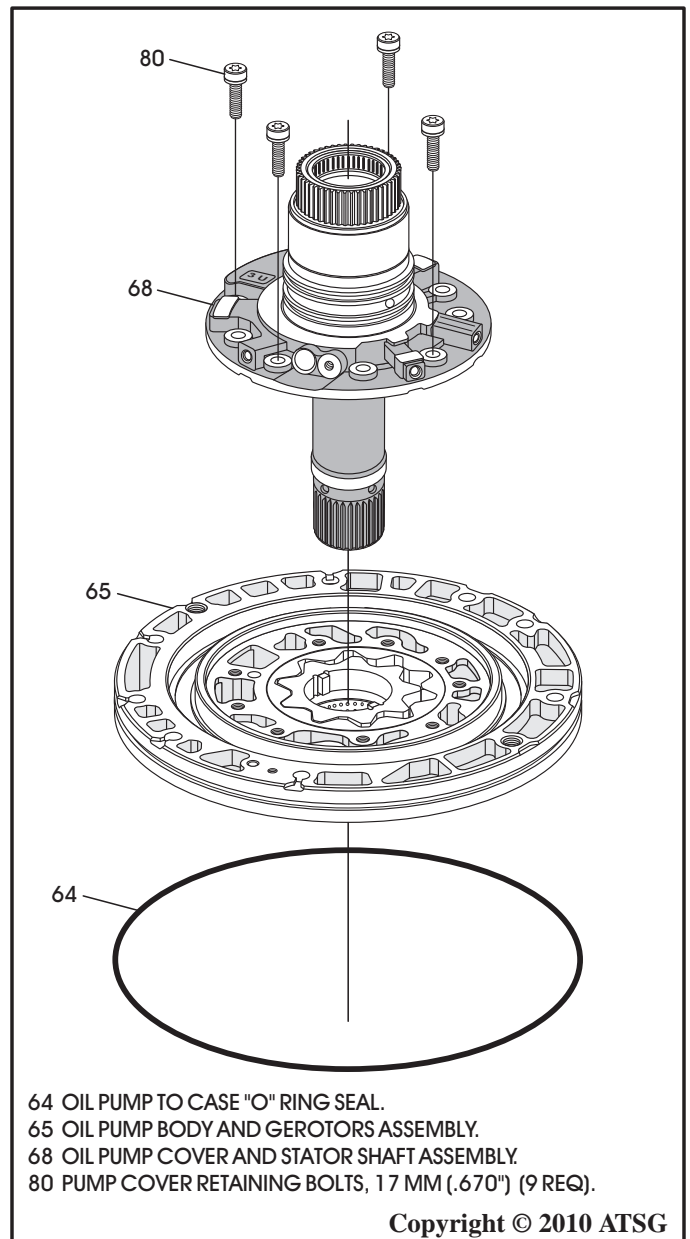

Figure 160

COMPONENT REBUILD (CONT'D)

OIL PUMP ASSEMBLY (CONT'D)

14. Install the B1 clutch apply piston in oil pump body, as shown in Figure 161.
Note: B1 clutch piston has a guide pin cast on bottom of piston, that fits into the cavity that is shown in Figure 162, to properly align the piston for the return spring.
15. Install B1 clutch piston return spring assembly, as shown in Figure 161, and install remaining five pump cover to pump body bolts.

16. Torque all nine of the oil pump retaining bolts to 18 N·m (13 ft.lb.) (See Figure 163).

Continued on Page 90

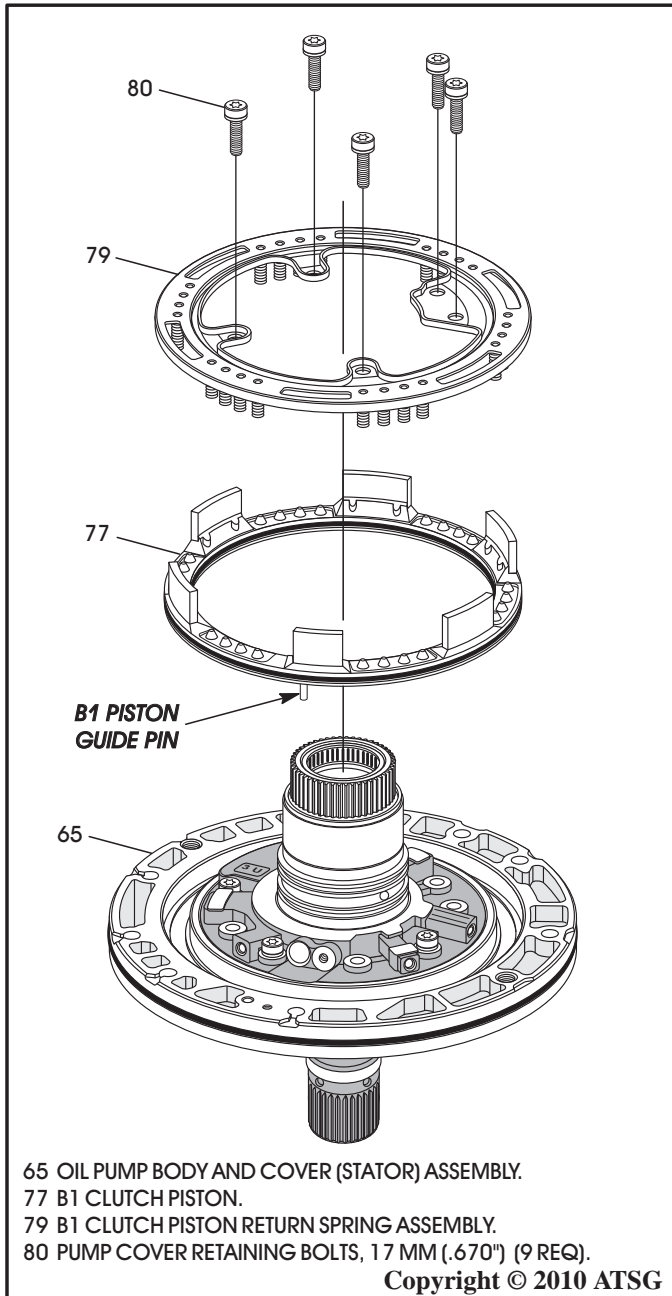

Figure 161

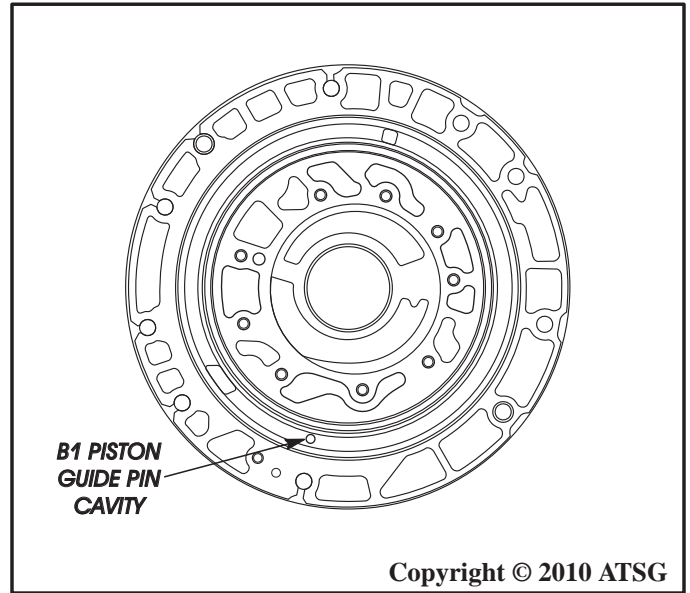

Figure 162

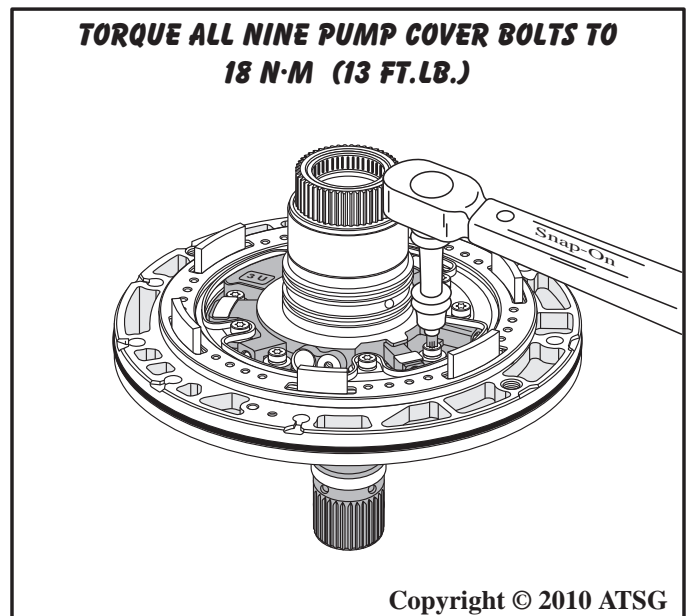

Figure 163

COMPONENT REBUILD (CONT'D)

OIL PUMP ASSEMBLY (CONT'D)

17. Install the turbine shaft speed sensor into the pump cover, as shown in Figure 164, install the retaining bolt.
18. Place the yellow connector into the cavity in the pump body, as shown in Figure 164, install the retaining bolt.
19. Torque both bolts to 6 N·m (53 in.lb.).
20. Install the number 1 thrust washer steel race, as shown in Figure 165, and retain with small amount of Trans-Jel®.
- Note: Ensure the inside tab is in the proper location on pump cover.**
21. Install two new K3 sealing rings into grooves on pump cover, as shown in Figure 165.
22. Set the completed oil pump assembly aside for the final assembly process (See Figure 166).

**Component Rebuild
Continued on Page 91**

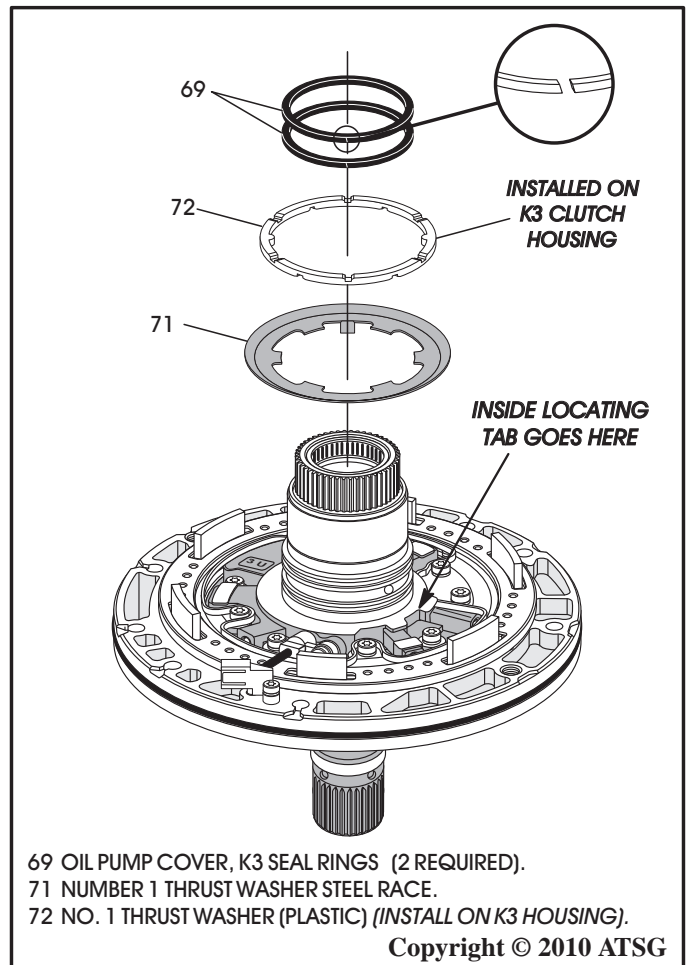

Figure 165

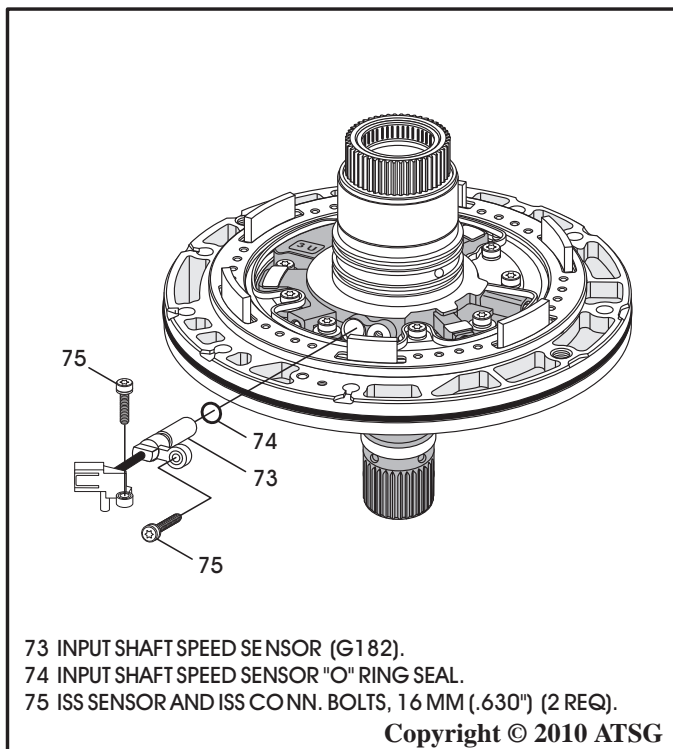

Figure 164

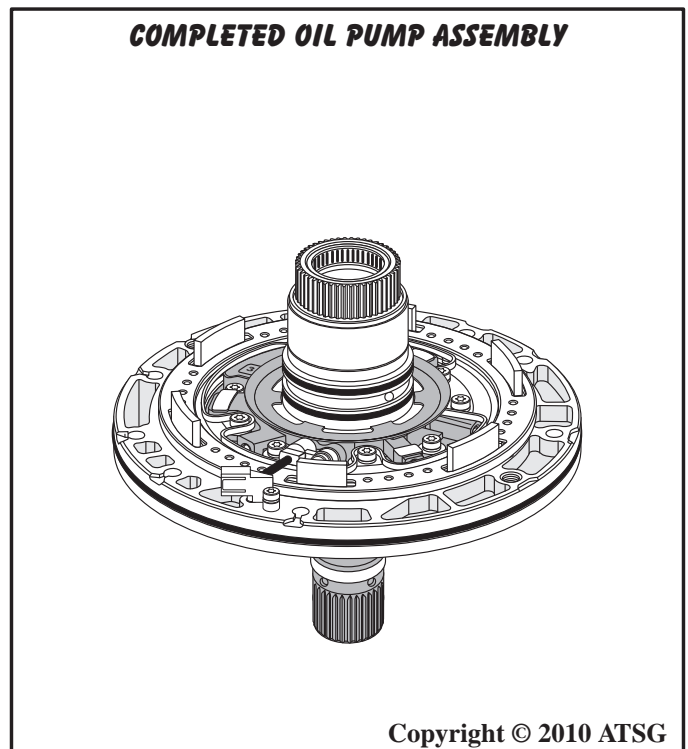

Figure 166

COMPONENT REBUILD (CONT'D)

VALVE BODY ASSEMBLY

1. Lay the valve body assembly on a flat work surface, as shown in Figure 167.
2. Remove the seven bolts retaining the manual valve body, as shown in Figure 167.
3. Remove the manual valve body and manual valve, as shown in Figure 167.
4. Turn the valve body assembly over, as shown in Figure 168.
5. Remove the 39 upper to lower valve body bolts, as shown in Figure 168.

Note: There are three different lengths of these bolts See Legend in Figure 168.

6. Remove the two oil baffles, as shown in Figure 168.
7. Separate the upper valve body, spacer plate and lower valve body.

Continued on Page 92

Special Note: This valve body has proven to have very high bore wear and Sonnax® has available several line-ups that may save you from having to purchase a new valve body.

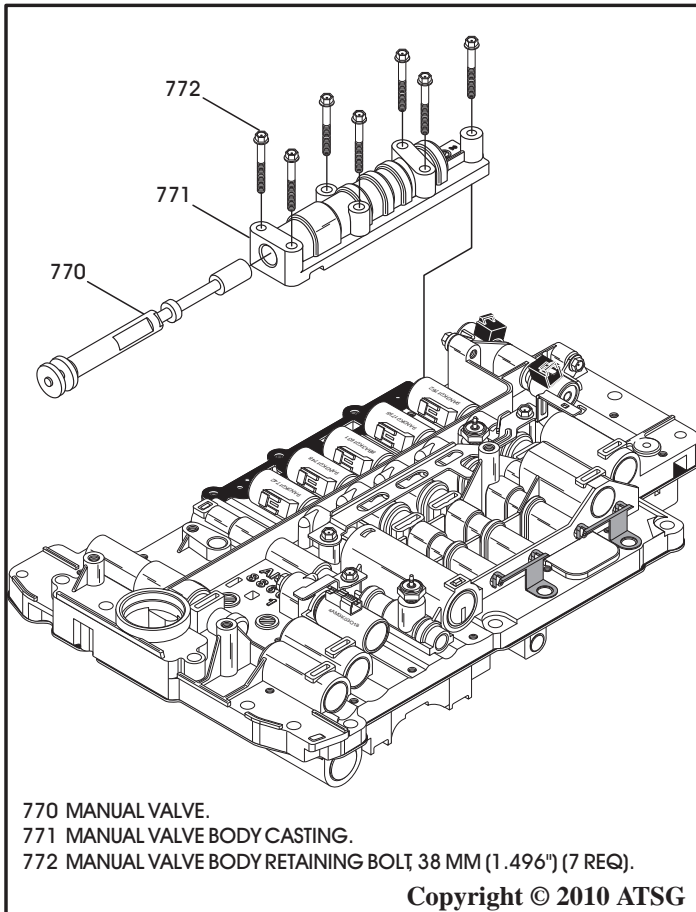

Figure 167

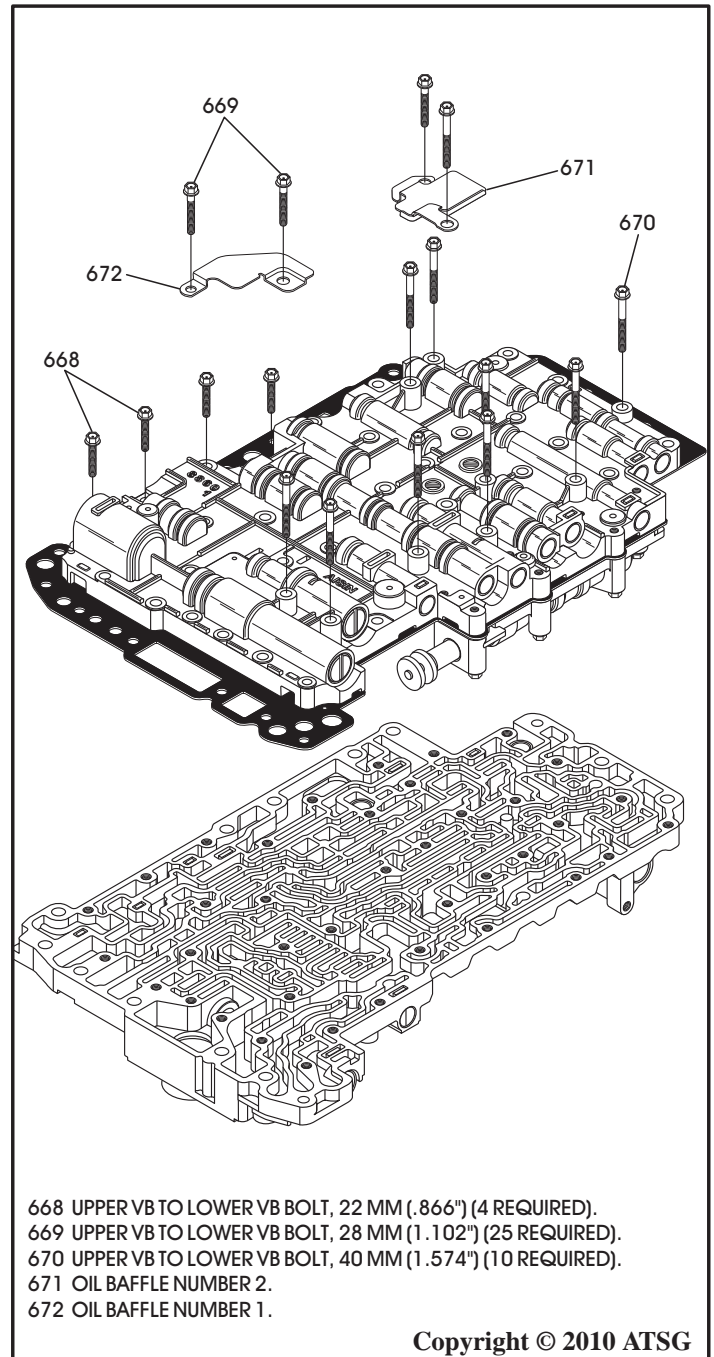

Figure 168

VALVE BODY ASSEMBLY (CONT'D)

8. Disassemble lower valve body and place valves, springs, bore plugs and retainers on appropriate trays *exactly* as they are removed, as shown in Figure 169. Small parts are shown in Figure 172.

Note: Tag the "Linear" solenoid locations on removal, as they are position sensitive.

9. Clean all lower valve body parts thoroughly and dry with compressed air.

Note: Do not submerge solenoids in solvent.

Caution:

There are 4 adjustable plugs screwed into the valve body casting at the end of the clutch regulating bores, as shown in Figure 169, along with two clips that are not necessary to remove. If removal does become necessary, measure plug depth before plug is removed as it is a critical adjustment.

Continued on Page 93

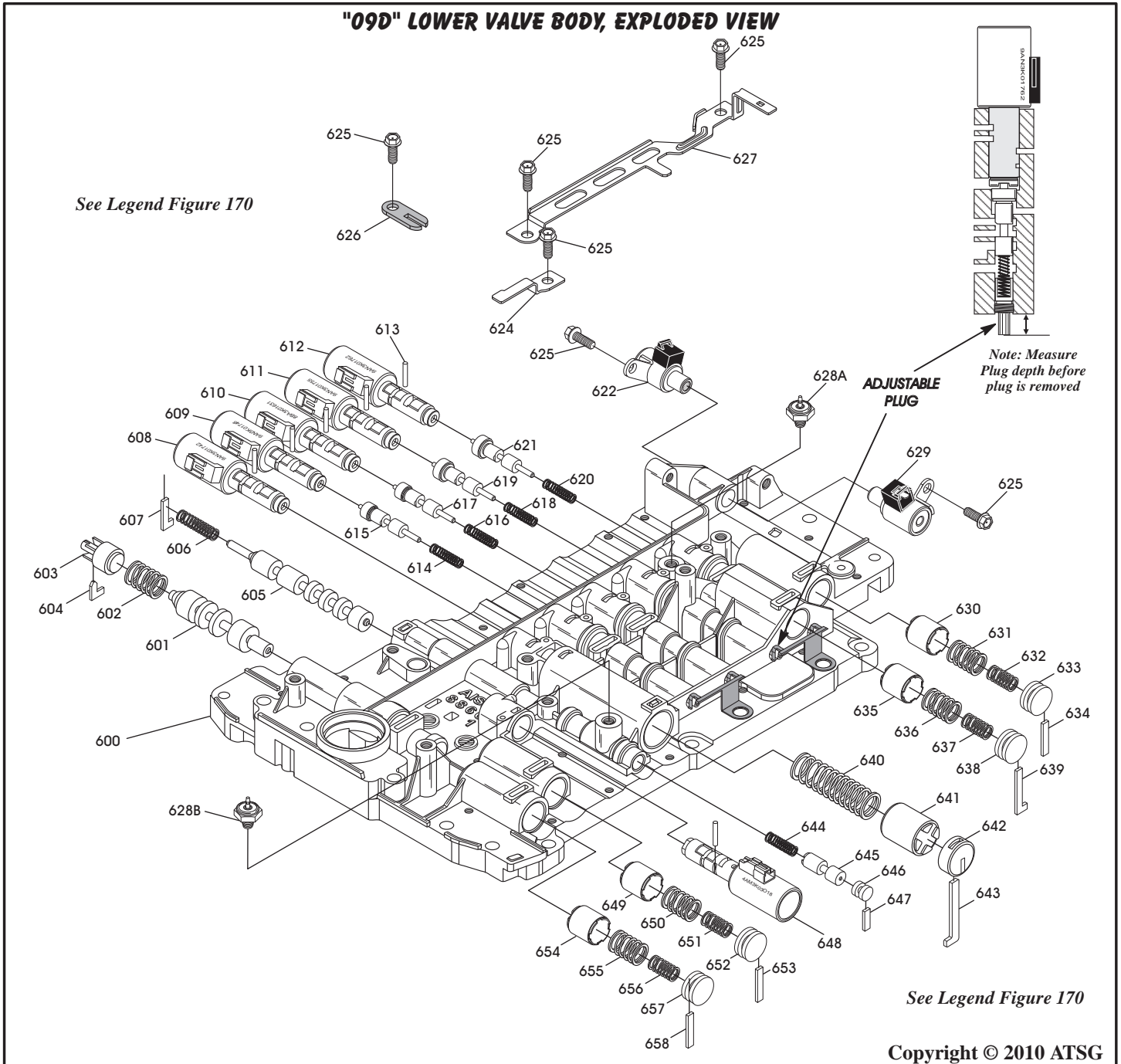

Figure 169

FIGURE 169 AND 172 LEGEND

- 600 LOWER VALVE BODY CASTING.
- 601 SECONDARY PRESSURE REGULATOR VALVE.
- 602 SECONDARY PRESSURE REGULATOR VALVE SPRING (RED).
- 603 SECONDARY PRESSURE REGULATOR VALVE ADJUSTMENT PLUG.
- 604 SECONDARY PRESSURE REGULATOR VALVE ADJUSTMENT RETAINER.
- 605 NUMBER 1 RELAY VALVE.
- 606 NUMBER 1 RELAY VALVE SPRING (NONE).
- 607 NUMBER 1 RELAY VALVE RETAINER.
- 608 N93 P WM LINE PRESSURE CONTROL SOLENOID.
- 609 N92 P WM K1 CLUTCH CONTROL SOLENOID.
- 610 N90 P WM K3 CLUTCH CONTROL SOLENOID.
- 611 N283 P WM B1 CLUTCH CONTROL SOLENOID.
- 612 N282 P WM K2 CLUTCH CONTROL SOLENOID).
- 613 P WM SOLENOID RETAINER PINS (6 REQUIRED).
- 614 K1 CLUTCH REGULATOR VALVE SPRING (RED).
- 615 K1 CLUTCH REGULATOR VALVE.
- 616 K3 CLUTCH REGULATOR VALVE SPRING (NONE).
- 617 K3 CLUTCH REGULATOR VALVE.
- 618 B1 CLUTCH REGULATOR VALVE SPRING (NONE).
- 619 B1 CLUTCH REGULATOR VALVE.
- 620 K2 CLUTCH REGULATOR VALVE SPRING (NONE).
- 621 K2 CLUTCH REGULATOR VALVE.
- 622 N89 ON/OFF SOLENOID.
- 624 N91 P WM TCC CONTROL SOLENOID PIN RETAINER.
- 625 RETAINING BOLTS, 12 MM (0.472") LONG (6 REQUIRED).
- 626 TRANSMISSION TEMP SENSOR RETAINING BRACKET.
- 627 N93, N90, N92, N283, N282 SOLENOID PIN RETAINER.
- 628A B2 PRESSURE SWITCH (NOT USED IN ALL MODELS).
- 628B K1 PRESSURE SWITCH (NOT USED IN ALL MODELS).
- 629 N88 ON/OFF SOLENOID.
- 630 K2 ACCUMULATOR PISTON.
- 631 K2 ACCUMULATOR PISTON OUTER SPRING (NONE).
- 632 K2 ACCUMULATOR PISTON INNER SPRING (GRAY).
- 633 K2 ACCUMULATOR PISTON BORE PLUG.
- 634 K2 ACCUMULATOR PISTON BORE PLUG RETAINER.
- 635 B1 ACCUMULATOR PISTON.
- 636 B1 ACCUMULATOR PISTON OUTER SPRING (NONE).
- 637 B1 ACCUMULATOR PISTON INNER SPRING (GRAY).
- 638 B1 ACCUMULATOR PISTON BORE PLUG.
- 639 B1 ACCUMULATOR PISTON BORE PLUG RETAINER.
- 640 FORWARD ENGAGEMENT ACCUMULATOR SPRING (NONE).
- 641 FORWARD ENGAGEMENT ACCUMULATOR PISTON.
- 642 FORWARD ENGAGEMENT ACCUMULATOR BORE PLUG.
- 643 FORWARD ENGAGEMENT ACCUMULATOR BORE PLUG RETAINER.
- 644 K1 SWITCH VALVE SPRING (PINK).
- 645 K1 SWITCH VALVE.
- 646 K1 SWITCH VALVE BORE PLUG.
- 647 K1 SWITCH VALVE BORE PLUG RETAINER.
- 648 N91 P WM TCC CONTROL SOLENOID.
- 649 N93/LINE PRESSURE SOLENOID ACCUMULATOR PISTON.
- 650 N93 ACCUMULATOR PISTON OUTER SPRING (NONE).
- 651 N93 ACCUMULATOR PISTON INNER SPRING (GRAY).
- 652 N93 ACCUMULATOR PISTON BORE PLUG.
- 653 N93 ACCUMULATOR PISTON BORE PLUG RETAINER.
- 654 K3 ACCUMULATOR PISTON.
- 655 K3 ACCUMULATOR PISTON OUTER SPRING (NONE).
- 656 K3 ACCUMULATOR PISTON INNER SPRING (GRAY).
- 657 K3 ACCUMULATOR PISTON BORE PLUG.
- 658 K3 ACCUMULATOR PISTON BORE PLUG RETAINER.
- 659 ROUND SCREENS (OPEN SIDE FACES SPACER PLATE) (2 REQ).
- 660 VALVE BODY SPACER PLATE.
- 661 OVAL SCREEN (OPEN SIDE FACES SPACER PLATE).
- 662 K3 EXHAUST CHECK VALVE, 9.96 MM (.392") DIAMETER.
- 663 K3 EXHAUST CHECK VALVE SPRING (WHITE).
- 664 REGULATED EXHAUST CHECK VALVE, 9.96 MM (.392") DIA.
- 665 REGULATED EXHAUST CHECK VALVE SPRING (WHITE).
- 666 B2 CLUTCH PLASTIC CHECK VALVE ASSEMBLY.
- 667 FORWARD/K2 PLASTIC CHECK VALVE ASSEMBLY.

Figure 170

VALVE BODY ASSEMBLY (CONT'D)

10. Inspect all lower valve body parts thoroughly for any wear and/or damage.
Note: See observed spring specs in Figure 171.
11. Assemble the lower valve body parts *exactly* as shown in Figure 169, and lube with the proper ATF as they are installed.
12. Torque the solenoid retaining bracket bolts to 10 N·m (89 in.lb.).

Continued on Page 94

SPECIAL NOTE: VALVE NAMES SHOWN WERE ASSIGNED BY ATSG BASED ON THEIR FUNCTION.

LOWER VALVE BODY SPRING SPECIFICATIONS

SPRING NUMBER 602 Free Length = 1.043" Spring Diameter = .623" Wire Diameter = .052" Approx Coils = 6 (RED)	SPRING NUMBER 620 Free Length = .860" Spring Diameter = .235" Wire Diameter = .032" Approx Coils = 13 (NONE)
SPRING NUMBER 606 Free Length = 1.560" Spring Diameter = .355" Wire Diameter = .025" Approx Coils = 13 (NONE)	SPRINGS 631, 636, 650, 655, Free Length = 1.085" Spring Diameter = .628" Wire Diameter = .082" Approx Coils = 6.5 (NONE)
SPRING NUMBER 614 Free Length = 1.018" Spring Diameter = .235" Wire Diameter = .025" Approx Coils = 14 (RED)	SPRINGS 632, 637, 651, 656, Free Length = 1.093" Spring Diameter = .430" Wire Diameter = .062" Approx Coils = 8.5 (GRAY)
SPRING NUMBER 616 Free Length = .860" Spring Diameter = .235" Wire Diameter = .032" Approx Coils = 13 (NONE)	SPRING NUMBER 640 Free Length = 2.456" Spring Diameter = .775" Wire Diameter = .075" Approx Coils = 10 (NONE)
SPRING NUMBER 618 Free Length = .860" Spring Diameter = .235" Wire Diameter = .032" Approx Coils = 13 (NONE)	SPRING NUMBER 644 Free Length = 1.090" Spring Diameter = .280" Wire Diameter = .025" Approx Coils = 11 (PINK)

LOWER VALVE BODY SPRING SPECIFICATIONS SMALL PARTS, WORM TRACK SIDE

SPRING NO. 663 Free Length = .600" Spring Diameter = .248" Wire Diameter = .023" Approx Coils = 11 (WHITE)	SPRING NO. 665 Free Length = .600" Spring Diameter = .248" Wire Diameter = .023" Approx Coils = 11 (WHITE)
--	--

Copyright © 2010 ATSG

Figure 171

VALVE BODY ASSEMBLY (CONT'D)

13. Assemble the worm track small parts into lower valve body *exactly*, as shown in Figure 172.
14. Disassemble upper valve valve body and place valves, springs, bore plugs and retainers on appropriate trays *exactly* as they were removed, as shown in Figure 173. Small parts are shown in Figure 175.
15. Inspect all upper valve body parts thoroughly for any wear and/or damage.
Note: See spring specs in Figure 176.

- Caution: Solenoid modulator valves (725), (733) have high failure rates. Check bores carefully. Available from Sonnax®, see Figure 173.*
16. Assemble the upper valve body parts *exactly* as shown in Figure 173, and lube with the proper ATF as they are installed.
Note: Retainer for bore plug 681 will require some Trans-Jel® as it is not spring loaded.
 17. Install the worm track small parts into the upper valve body *exactly* as shown in Figure 175.

Continued on Page 98

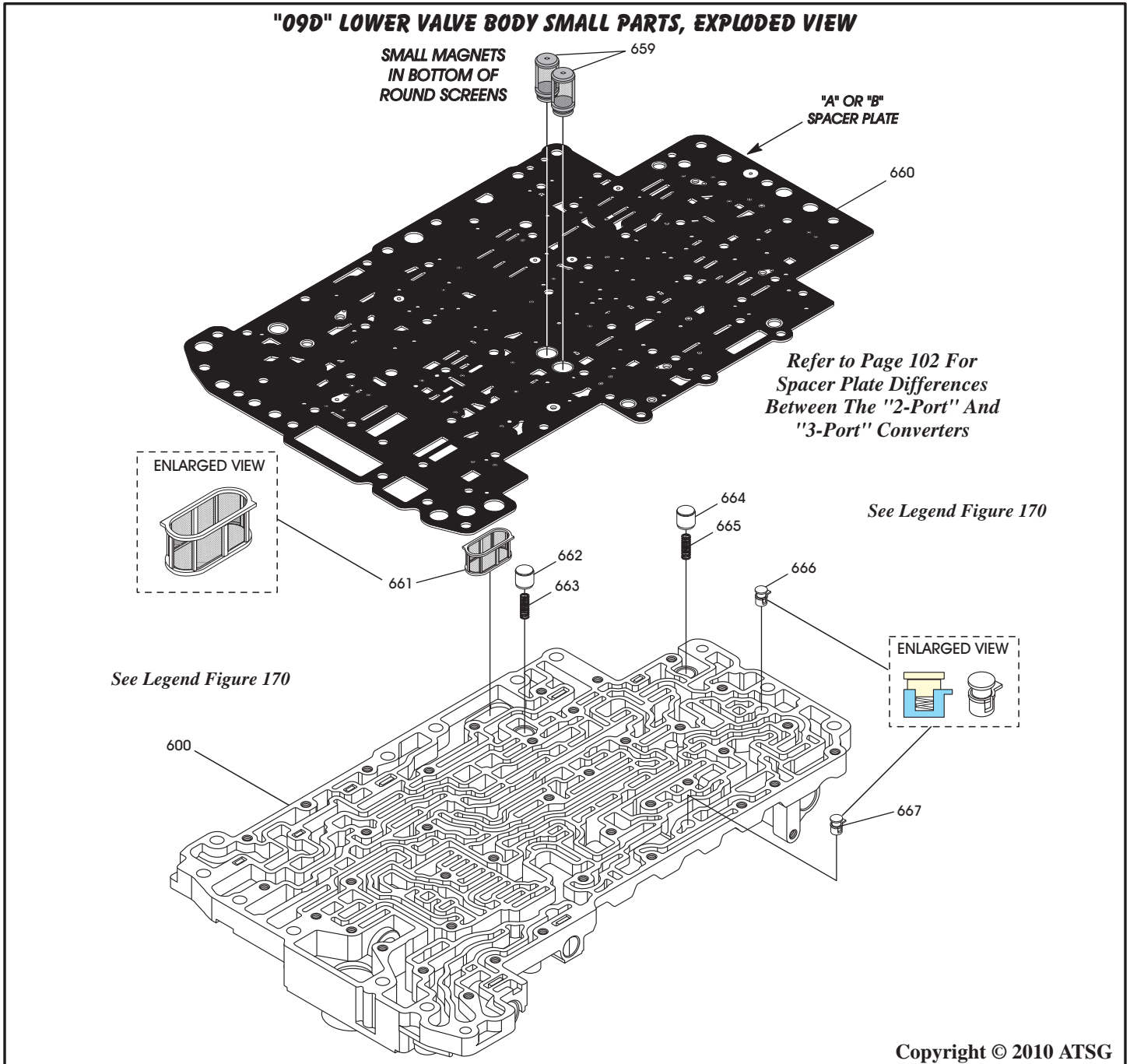

Figure 172

"09D" UPPER VALVE BODY EXPLODED VIEW

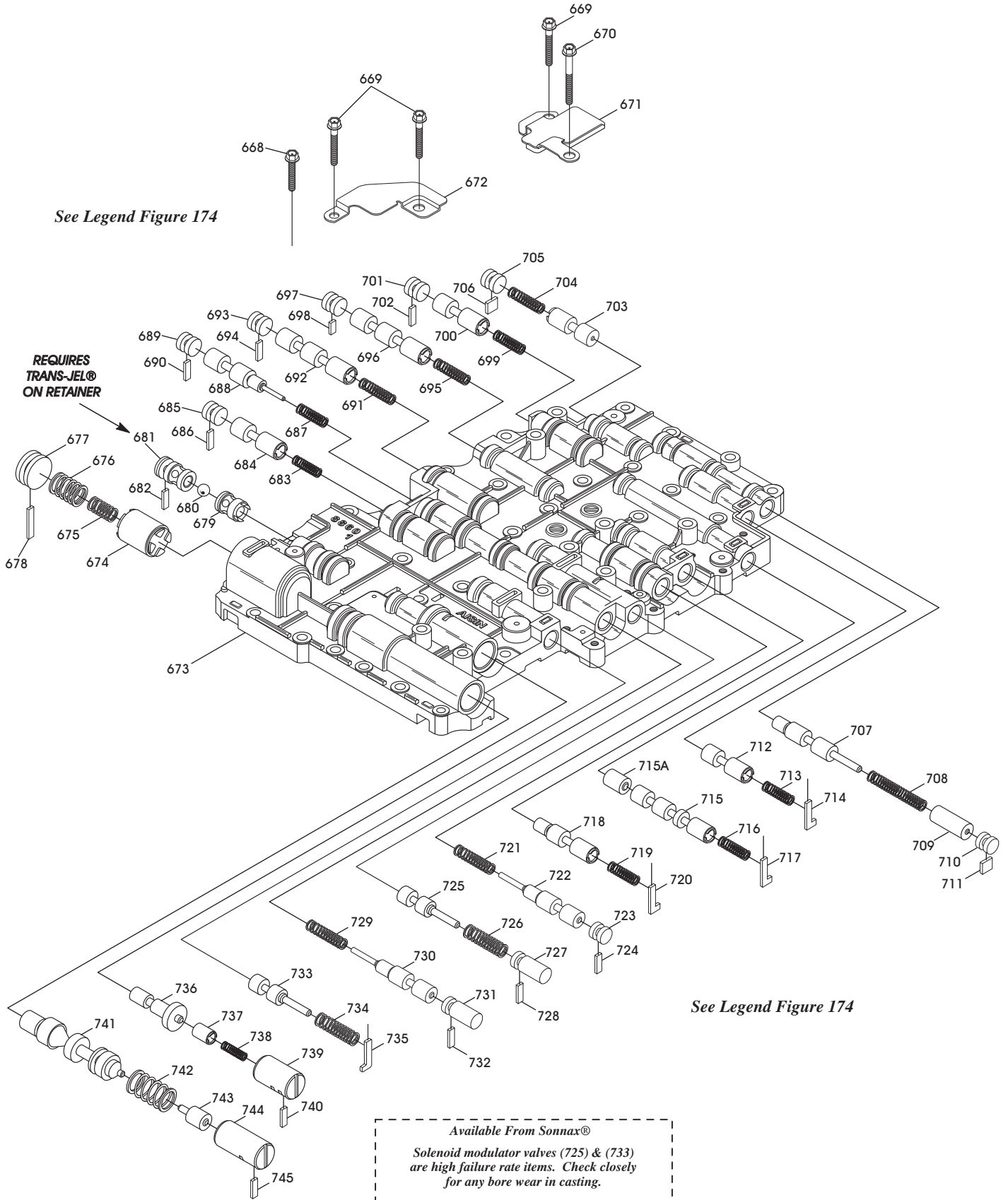

Figure 173

FIGURE 173 AND 175 LEGEND

659 ROUND SCREENS (2 REQUIRED).	720 B2 PORT CONTROL VALVE RETAINER.
660 VALVE BODY SPACER PLATE.	721 B1 RELAY VALVE SPRING (ORANGE).
668 UPPER VB TO LOWER VB BOLT, 22 MM (.866") (4 REQUIRED).	722 B1 RELAY VALVE.
669 UPPER VB TO LOWER VB BOLT, 28 MM (1.102") (25 REQUIRED).	723 B1 RELAY VALVE BORE PLUG.
670 UPPER VB TO LOWER VB BOLT, 40 MM (1.574") (10 REQUIRED).	724 B1 RELAY VALVE BORE PLUG RETAINER.
671 OIL BAFFLE NUMBER 2.	725 SOLENOID MODULATOR VALVE B VALVE.
672 OIL BAFFLE NUMBER 1.	726 SOLENOID MODULATOR VALVE B VALVE SPRING (LT BLUE).
673 UPPER VALVE BODY CASTING.	727 SOLENOID MODULATOR VALVE B VALVE BORE PLUG.
674 K1 ACCUMULATOR PISTON.	728 SOLENOID MODULATOR VALVE B VALVE BORE PLUG RETAINER.
675 K1 ACCUMULATOR PISTON INNER SPRING (LT BLUE).	729 K3 RELAY VALVE SPRING (ORANGE).
676 K1 ACCUMULATOR PISTON OUTER SPRING (NONE).	730 K3 RELAY VALVE.
677 K1 ACCUMULATOR PISTON BORE PLUG.	731 K3 RELAY VALVE BORE PLUG.
678 K1 ACCUMULATOR PISTON BORE PLUG RETAINER.	732 K3 RELAY VALVE BORE PLUG RETAINER.
679 K3/B1 THREE WAY INNER SHUTTLE BALL SEAT.	733 SOLENOID MODULATOR VALVE A VALVE.
680 SHUTTLE BALL (.250" DIAMETER STEEL).	734 SOLENOID MODULATOR VALVE A SPRING (LT BLUE).
681 K3/B1 THREE WAY OUTER SHUTTLE BALL SEAT.	735 SOLENOID MODULATOR VALVE A RETAINER.
682 K3/B1 THREE WAY OUTER SHUTTLE BALL SEAT RETAINER.	736 TCC APPLY CONTROL VALVE.
683 N283 SWITCH VALVE SPRING (PINK).	737 TCC APPLY CONTROL BOOST VALVE.
684 N283 SWITCH VALVE.	738 TCC APPLY CONTROL BOOST VALVE SPRING (TAN).
685 N283 SWITCH VALVE BORE PLUG.	739 TCC APPLY CONTROL BOOST VALVE SLEEVE.
686 N283 SWITCH VALVE BORE PLUG RETAINER.	740 TCC APPLY CONTROL BOOST VALVE SLEEVE RETAINER.
687 N90 SWITCH VALVE SPRING (ORANGE).	741 PRIMARY PRESSURE REGULATOR VALVE.
688 N90 SWITCH VALVE.	742 PRIMARY PRESSURE REGULATOR VALVE SPRING (PINK).
689 N90 SWITCH VALVE BORE PLUG.	743 LINE PRESSURE BOOST VALVE.
690 N90 SWITCH VALVE BORE PLUG RETAINER.	744 LINE PRESSURE BOOST VALVE SLEEVE.
691 K3 CONTROL VALVE SPRING (PINK).	745 LINE PRESSURE BOOST VALVE SLEEVE RETAINER.
692 K3 CONTROL VALVE.	746 LUBE CHECK VALVE SPRING (PINK).
693 K3 CONTROL VALVE BORE PLUG.	747 LUBE CHECK VALVE, 9.98 MM (.392") DIAMETER.
694 K3 CONTROL VALVE BORE PLUG RETAINER.	748 SECONDARY REG. VALVE PLASTIC CHECK VALVE ASSEMBLY.
695 B1 CONTROL VALVE SPRING (PINK).	749 TCC APPLY LIMIT CHECK VALVE SPRING (VIOLET).
696 B1 CONTROL VALVE.	750 TCC APPLY LIMIT CHECK VALVE, 9.98 MM (.392") DIAMETER.
697 B1 CONTROL VALVE BORE PLUG.	751 N93 SOLENOID LIMIT CHECK VALVE SPRING (LT BLUE).
698 B1 CONTROL VALVE BORE PLUG RETAINER.	752 N93 SOLENOID LIMIT CHECK VALVE, 11.98 MM (.471") DIAMETER.
699 K2 CONTROL VALVE SPRING (PINK).	753 REVERSE LIMIT CHECK VALVE SPRING (WHITE).
700 K2 CONTROL VALVE.	754 REVERSE LIMIT CHECK VALVE, 9.98 MM (.392") DIAMETER.
701 K2 CONTROL VALVE BORE PLUG.	755 REVERSE ORIFICE PLASTIC CHECK BALL, 5.5 MM (.217") DIA.
702 K2 CONTROL VALVE BORE PLUG RETAINER.	756 LINE PRESSURE LIMIT CHECK VALVE SPRING (NONE).
703 B2 SWITCH VALVE (MANUAL "1") VALVE.	757 LINE PRESSURE LIMIT CHECK VALVE, 9.98 MM (.392") DIAMETER.
704 B2 SWITCH VALVE (MANUAL "1") SPRING (WHITE).	758 REGULATED EXHAUST CHECK VALVE SPRING (WHITE).
705 B2 SWITCH VALVE (MANUAL "1") BORE PLUG.	759 REGULATED EXHAUST CHECK VALVE, 9.98 MM (.392") DIAMETER.
706 B2 SWITCH VALVE (MANUAL "1") BORE PLUG RETAINER.	760 B2 "SMALL" CAVITY PLASTIC CHECK BALL, 5.5 MM (.217") DIA.
707 B2 REGULATOR VALVE.	761 LUBE RELIEF CHECK VALVE, 9.98 MM (.392") DIAMETER.
708 B2 REGULATOR VALVE SPRING (VIOLET).	762 LUBE RELIEF CHECK VALVE SPRING (RED).
709 B2 REGULATOR PLUNGER.	763 K2 CLUTCH PLASTIC CHECK VALVE ASSEMBLY.
710 B2 REGULATOR VALVE BORE PLUG.	764 B1 CLUTCH PLASTIC CHECK VALVE ASSEMBLY.
711 B2 REGULATOR VALVE BORE PLUG RETAINER.	765 K3 CLUTCH PLASTIC CHECK VALVE ASSEMBLY.
712 PRESSURE MODIFIER VALVE.	766 K1 CLUTCH PLASTIC CHECK VALVE ASSEMBLY.
713 PRESSURE MODIFIER SPRING (WHITE).	767 DRIVE RANGE ORIFICE PLASTIC CHECK BALL, 6.35 MM (.250") DIA.
714 PRESSURE MODIFIER RETAINER.	768 COOLER CHECK VALVE.
715A NUMBER 2 RELAY VALVE.	769 COOLER CHECK VALVE SPRING (TAN).
715 NUMBER 2 RELAY VALVE.	770 MANUAL VALVE.
716 NUMBER 2 RELAY VALVE SPRING (WHITE).	771 MANUAL VALVE BODY CASTING.
717 NUMBER 2 RELAY VALVE RETAINER.	772 MANUAL VALVE BODY RETAINING BOLT 38 MM (1.496") (7 REQ).
718 B2 PORT CONTROL VALVE.	
719 B2 PORT CONTROL VALVE SPRING (WHITE).	

Copyright © 2010 ATSG

Figure 174

**SPECIAL NOTE: VALVE NAMES SHOWN WERE
ASSIGNED BY ATSG BASED ON THEIR FUNCTION.**

"09D" UPPER VALVE BODY SMALL PARTS, EXPLODED VIEW

See Legend Figure 174

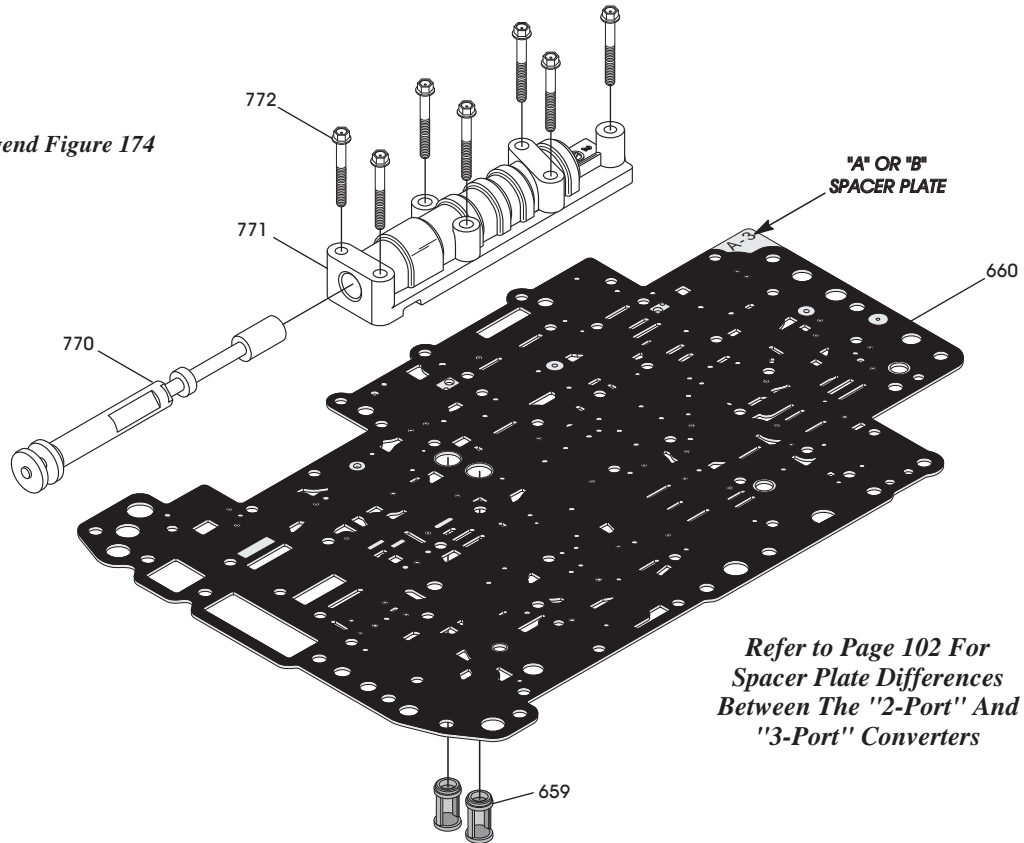

Refer to Page 102 For
Spacer Plate Differences
Between The "2-Port" And
"3-Port" Converters

See Legend Figure 174

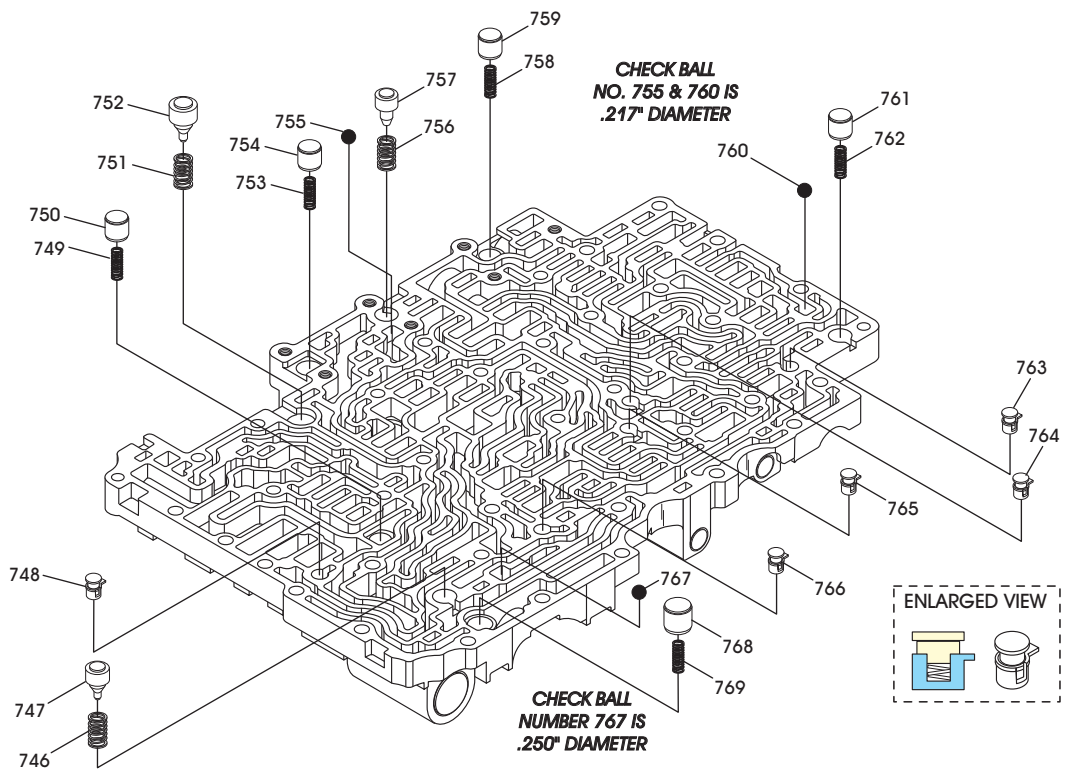

Copyright © 2010 ATSG

Figure 175

UPPER VALVE BODY SPRING SPECIFICATIONS

<p>SPRING NUMBER 675 Free Length = 1.070" Spring Diameter = .425" Wire Diameter = .062" Approx Coils = 9 (LT BLUE)</p>	<p>SPRING NUMBER 708 Free Length = 1.280" Spring Diameter = .275" Wire Diameter = .027" Approx Coils = 21 (VIOLET)</p>
<p>SPRING NUMBER 676 Free Length = 1.090" Spring Diameter = .625" Wire Diameter = .080" Approx Coils = 6 (NONE)</p>	<p>SPRING NUMBER 738 Free Length = .750" Spring Diameter = .220" Wire Diameter = .028" Approx Coils = 12 (TAN)</p>
<p>SPRING NUMBER 683, 691, 695, AND 699. Free Length = 1.080" Spring Diameter = .279" Wire Diameter = .024" Approx Coils = 10 (PINK)</p>	<p>SPRING NUMBER 726, 734, Free Length = 1.425" Spring Diameter = .386" Wire Diameter = .055" Approx Coils = 13 (LT BLUE)</p>
<p>SPRING NUMBER 687, 721, 729, Free Length = 1.130" Spring Diameter = .255" Wire Diameter = .027" Approx Coils = 13 (ORANGE)</p>	<p>SPRING NUMBER 742 Free Length = 1.235" Spring Diameter = .545" Wire Diameter = .048" Approx Coils = 6 (PINK)</p>
<p>SPRING NUMBER 704, 713, 716, AND 719. Free Length = 1.130" Spring Diameter = .297" Wire Diameter = .030" Approx Coils = 12 (WHITE)</p>	

UPPER VALVE BODY SPRING SPECIFICATIONS SMALL PARTS, WORM TRACK SIDE

<p>SPRING NO. 746 Free Length = .685" Spring Diameter = .346" Wire Diameter = .042" Approx Coils = 6 (PINK)</p>	<p>SPRING NO. 756 Free Length = .430" Spring Diameter = .373" Wire Diameter = .050" Approx Coils = 4 (NONE)</p>
<p>SPRING NO. 749 Free Length = .610" Spring Diameter = .249" Wire Diameter = .029" Approx Coils = 7 (VIOLET)</p>	<p>SPRING NO. 758 Free Length = .600" Spring Diameter = .248" Wire Diameter = .023" Approx Coils = 11 (WHITE)</p>
<p>SPRING NO. 751 Free Length = .700" Spring Diameter = .407" Wire Diameter = .035" Approx Coils = 6 (LT. BLUE)</p>	<p>SPRING NO. 762 Free Length = .625" Spring Diameter = .250" Wire Diameter = .033" Approx Coils = 8 (RED)</p>
<p>SPRING NO. 753 Free Length = .600" Spring Diameter = .248" Wire Diameter = .023" Approx Coils = 11 (WHITE)</p>	<p>SPRING NO. 769 Free Length = .672" Spring Diameter = .274" Wire Diameter = .019" Approx Coils = 10 (TAN)</p>

Copyright © 2010 ATSG

Figure 176

COMPONENT REBUILD (CONT'D) VALVE BODY ASSEMBLY (CONT'D)

- Install the two round screens into spacer plate with the plate oriented as shown in Figure 177, and the open end of screens toward the spacer plate.
Note: There are small magnets in the bottom of the two round screens.
Note: Refer to Page 102 for the spacer plate differences between the "2-Port" and "3-Port" torque converters.
- The screens will snap into spacer plate, ensure that they are fully seated.
Note: Valve body gaskets are bonded to all 09D spacer plates. Ensure that your gaskets are not damaged.

Continued on Page 99

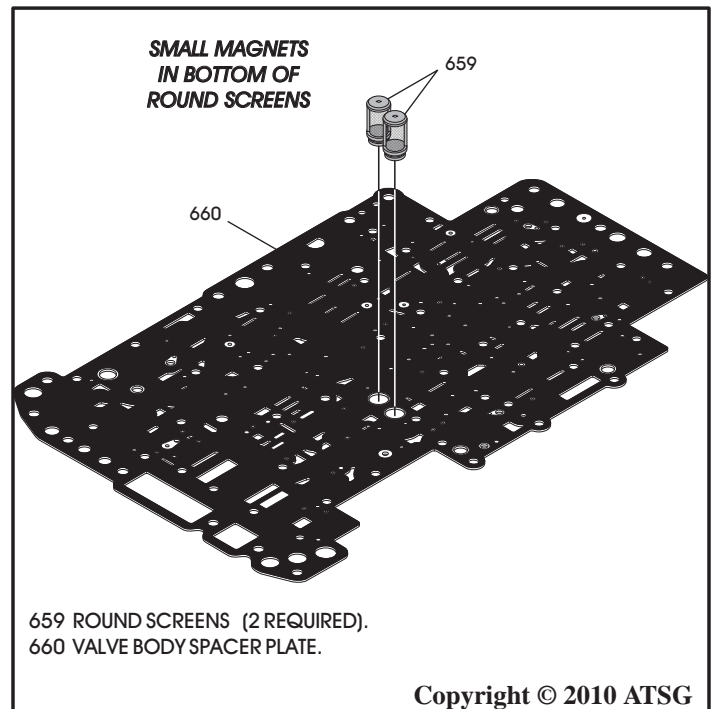

Copyright © 2010 ATSG

Figure 177

COMPONENT REBUILD (CONT'D)

VALVE BODY ASSEMBLY (CONT'D)

20. Install the manual valve into the manual valve body, as shown in Figure 178.
21. Lay the upper valve body on a flat work surface with the worm track side facing up, as shown in Figure 179.
22. Install two alignment dowels in the upper valve body in the positions shown in Figure 179.
Note: Manufacture alignment dowels from two extra manual valve body bolts.
23. With all small parts in their proper positions in the upper valve body, install spacer plate over alignment dowels and onto the upper valve body, as shown in Figure 179.
Note: Refer to Page 102 for the spacer plate differences between the "2-Port" and "3-Port" torque converters.
24. While holding the spacer plate down against spring pressure, install the manual valve body and manual valve over alignment dowels, as shown in Figure 179, and install four retaining bolts in the center and "snug" them down.
25. Remove the alignment dowels, and install the remaining three bolts. Tighten "snug".
26. Torque all seven manual valve body bolts to 10 N·m (89 in.lb.), as shown in Figure 180.

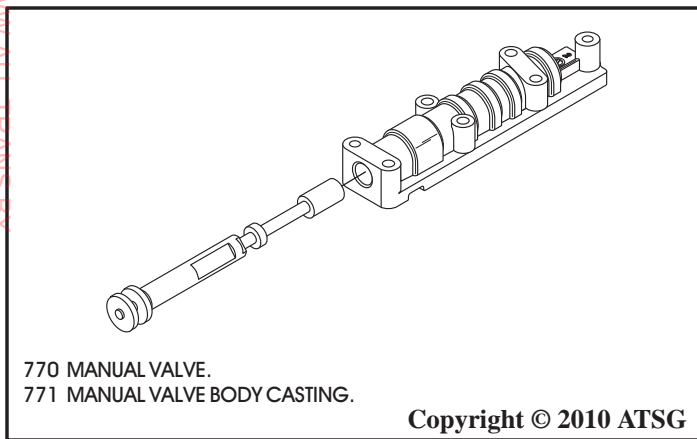

Figure 178

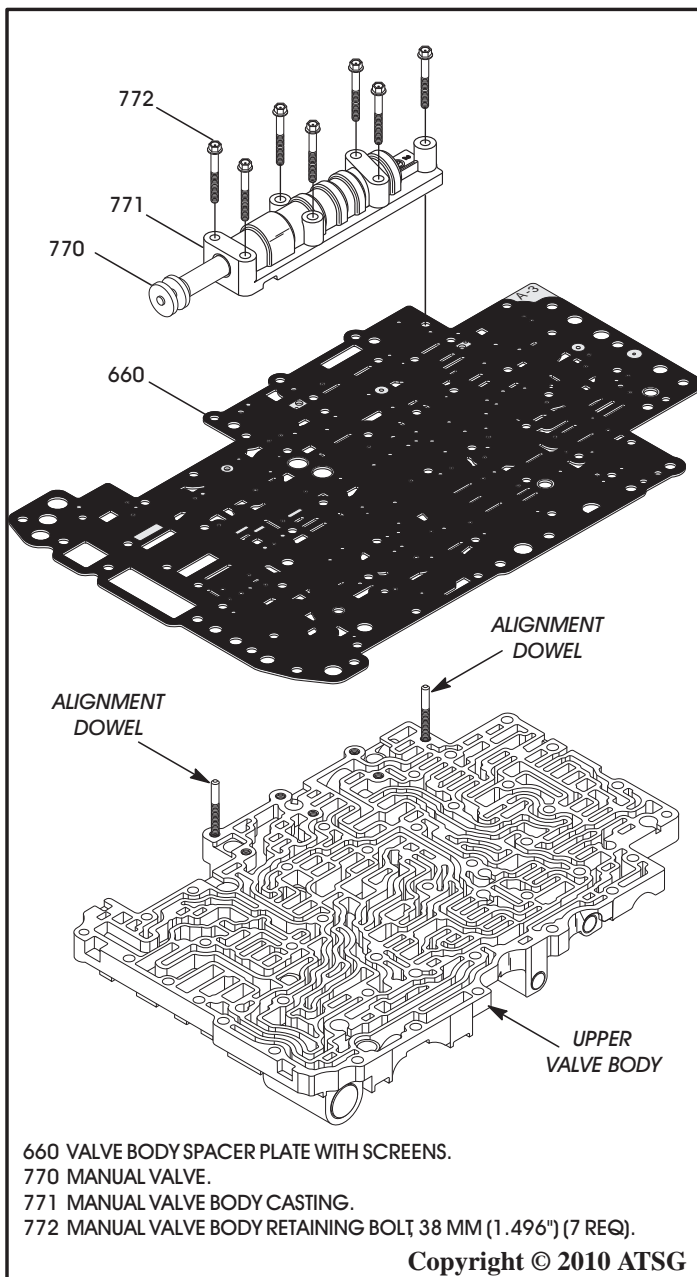

Figure 179

Continued on Page 100

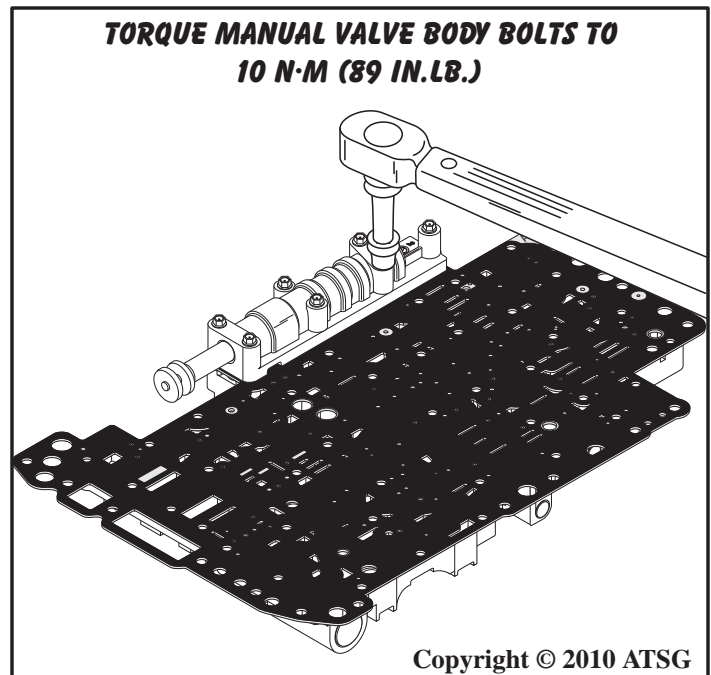

Figure 180

COMPONENT REBUILD (CONT'D)

VALVE BODY ASSEMBLY (CONT'D)

27. Install the same two alignment dowels in lower valve body in the positions shown in Figure 181.
28. With all small parts in their proper positions in the lower valve body, install upper valve body and spacer plate assembly over the alignment dowels and onto the lower valve body, as shown in Figure 181.
29. While holding pressure on the upper valve body install two bolts in the center and tighten "snug".

30. Remove the alignment dowels and install the remaining bolts and oil baffles in their proper positions, as shown in Figure 181.
Note: are 3 different lengths of bolts on this side of the valve body and their length and their position is shown in Figure 182.

Continued on Page 101

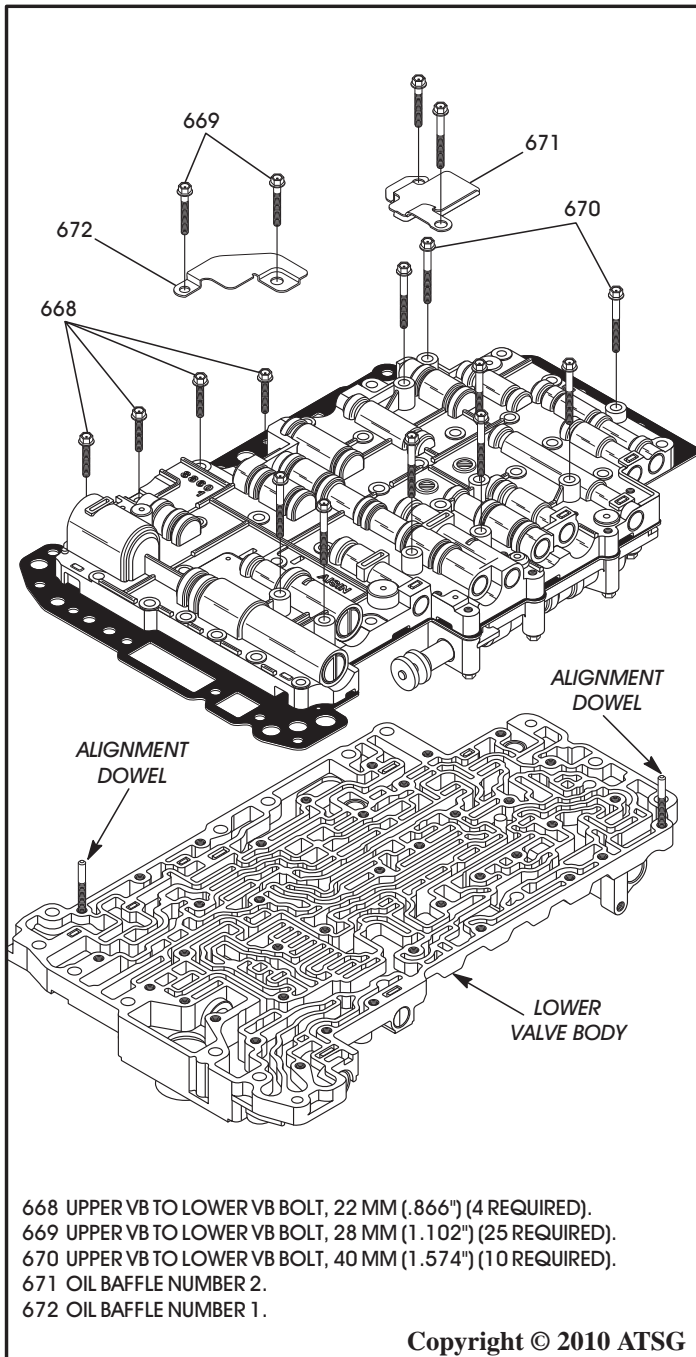

Figure 181

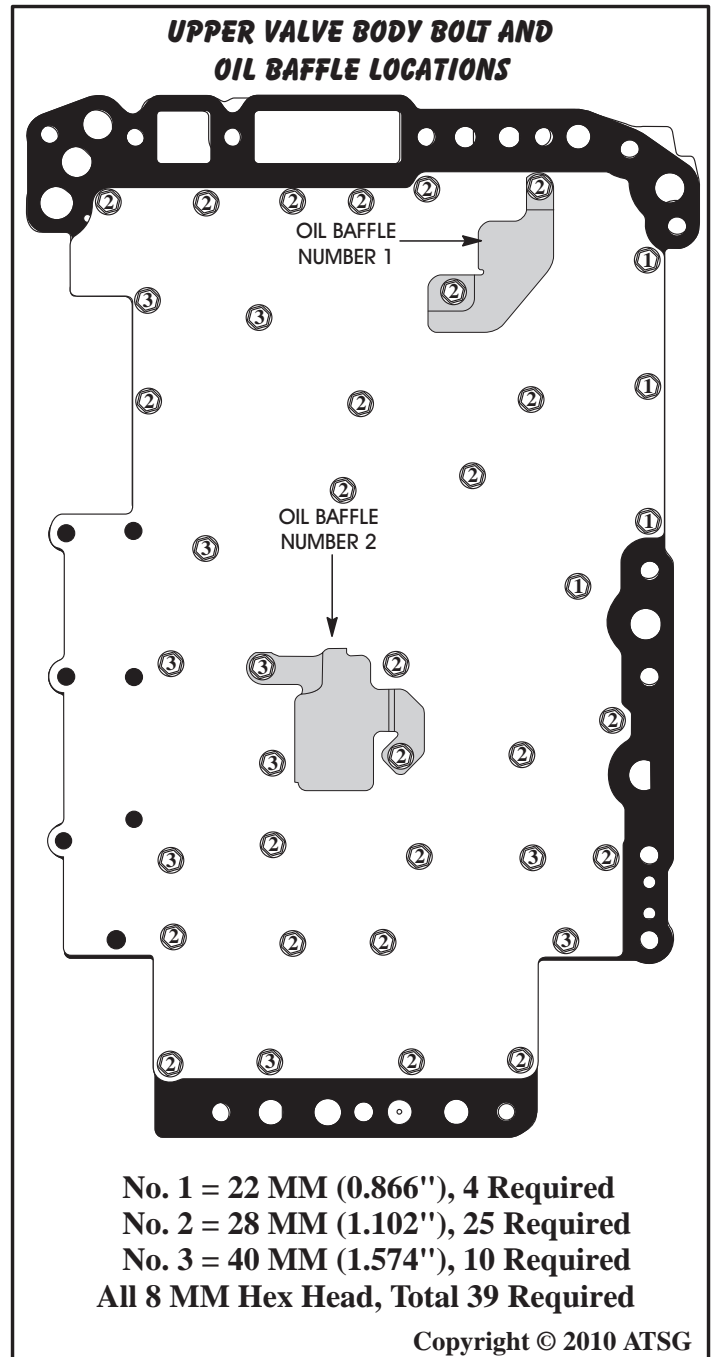

Figure 182

COMPONENT REBUILD (CONT'D)
VALVE BODY ASSEMBLY (CONT'D)

- 31. Torque all 39 upper valve body to lower valve body bolts to 10 N·m (89 in.lb.), as shown in Figure 183.
- 32. Set the completed valve body assembly aside for the final assembly process (See Figure 184).

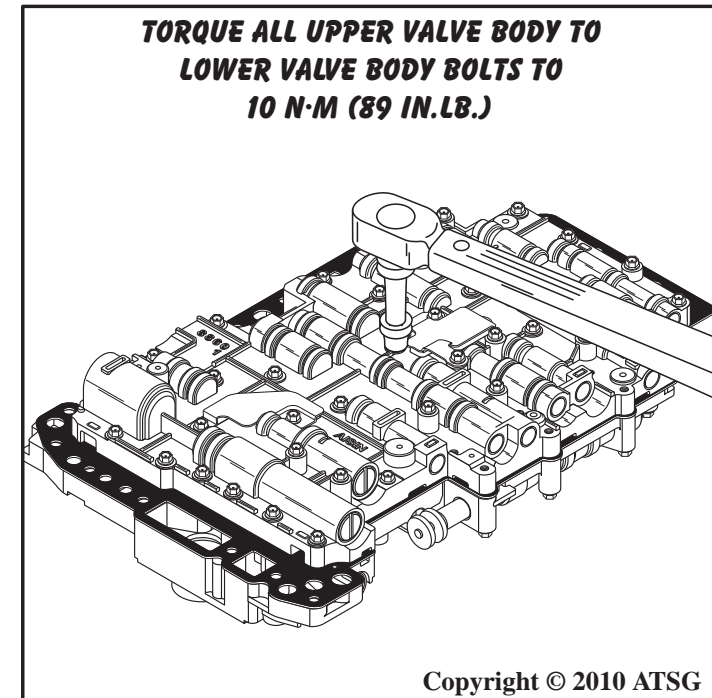

Figure 183

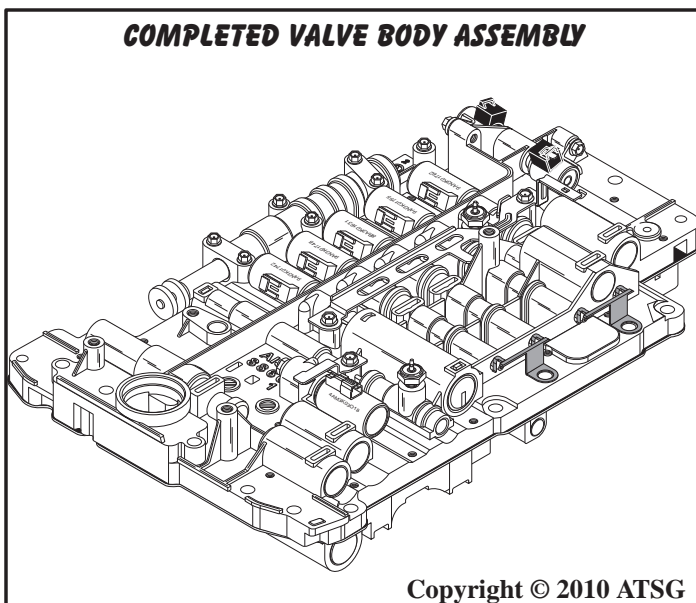

Figure 184

SPACER PLATE DIFFERENCES

The valve body spacer plates are different between the "2-Port" and "3-Port" torque converters. There are eight holes that are in different locations on each of the spacer plates. The holes that are different are "shaded-in" with a "dashed-circle" around the affected holes.

The valve body spacer plates are also identified as to which is the "2-Port" and which is the "3-Port" design and illustrated in Figure 185 below. Refer to Page 79 for additional information about "2-Port" and "3-Port" differences

These Spacer Plates "Will Not" Interchange!

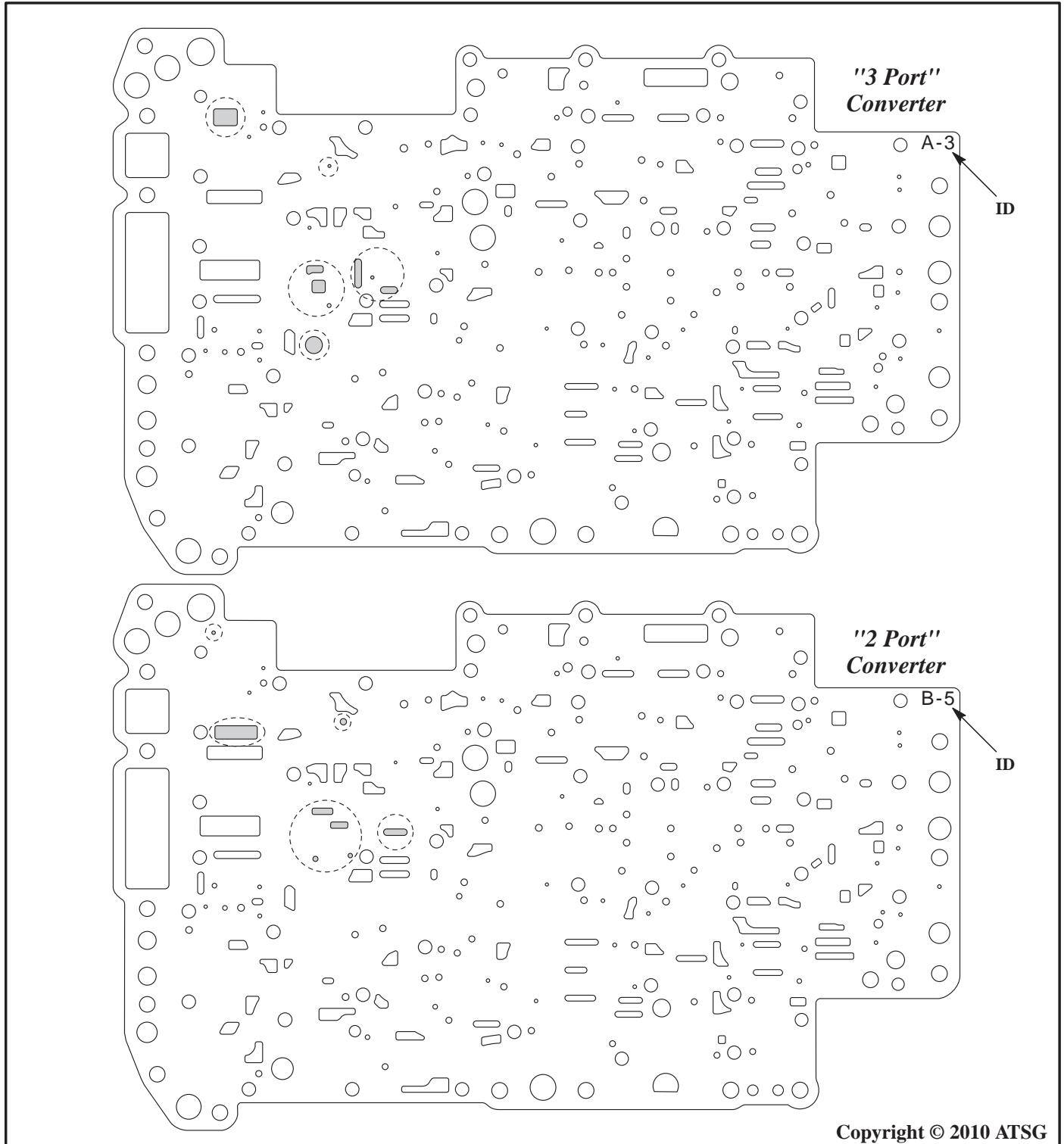

Copyright © 2010 ATSG

Figure 185

"UPDATED" VALVE BODY ASSEMBLY

Beginning sometime in 2005, Aisin introduced a "new design" valve body assembly that included hydraulic improvements, for both the "2-Port" and the "3-Port" design torque converters.

This "new design" valve body has an added TCC exhaust check valve, spring and retainer, as shown in Figure 186. We have also included casting number changes to assist you in visual identification between the the two new design valve bodies. The lower valve body is shown in Figure 186 and the upper valve body is shown in Figure 187.

The "new design" valve body also recieved some hydraulic improvements which required several worm track changes in both the upper and lower valve body castings. This of course also changed the spacer plate and identification, as it created two new spacer plates to accommodate the hydraulic changes, plus the "2-Port" and "3-Port" design converters.

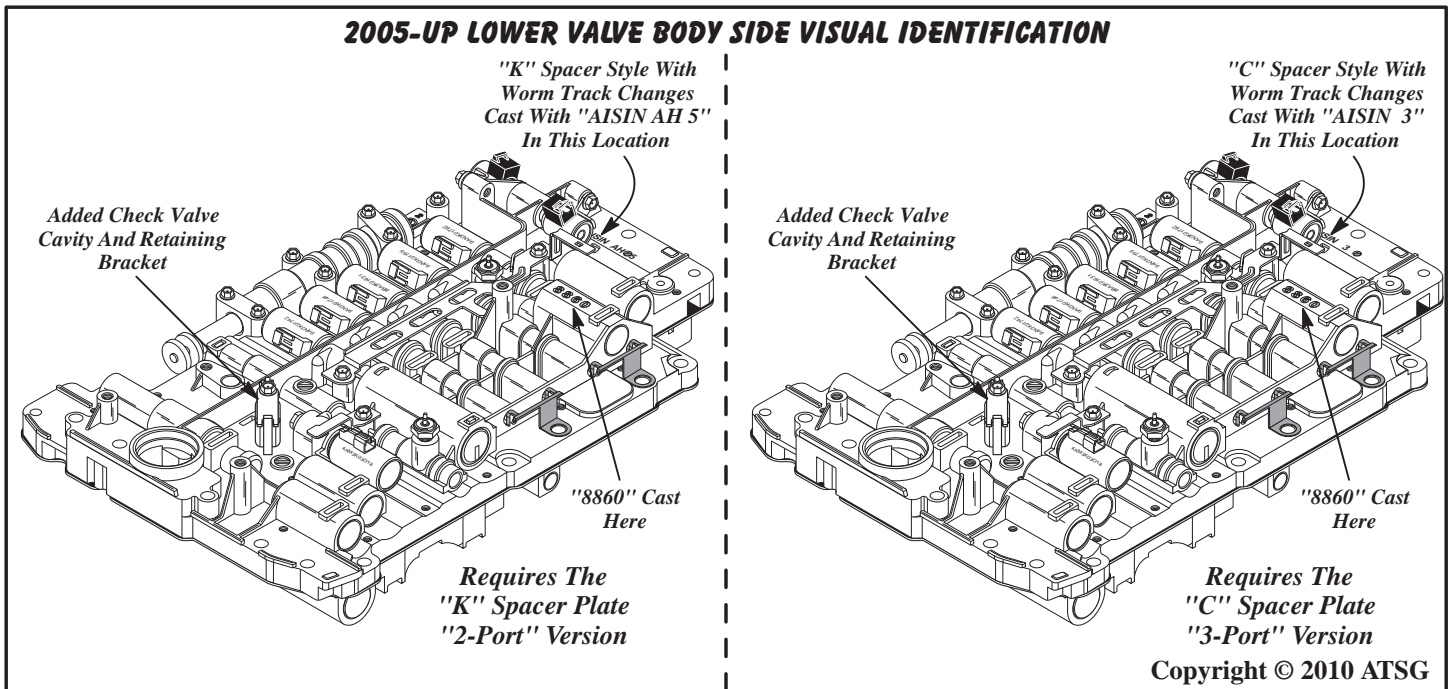

Figure 186

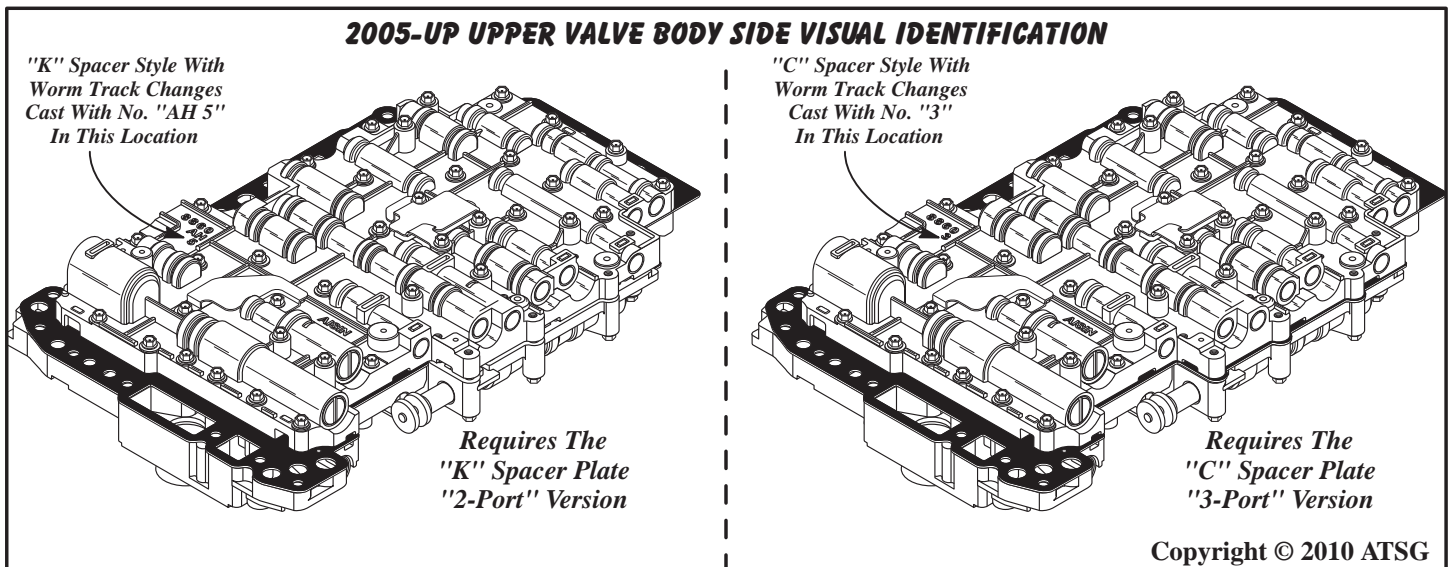

Figure 187

"UPDATED" VALVE BODY INFORMATION (CONT'D)

We have provided you with an exploded view of the 2005-up lower valve body assembly in Figure 188. There have also been several small changes to spring calibrations. The spring identification and all of the specifications for the 2005-up valve body, are provided for you in Figure 190.

The valve body assembly process is exactly the same as previous models and is covered in the valve body component rebuild section. It is only *some* internal components that have changed.

Continued on Page 106

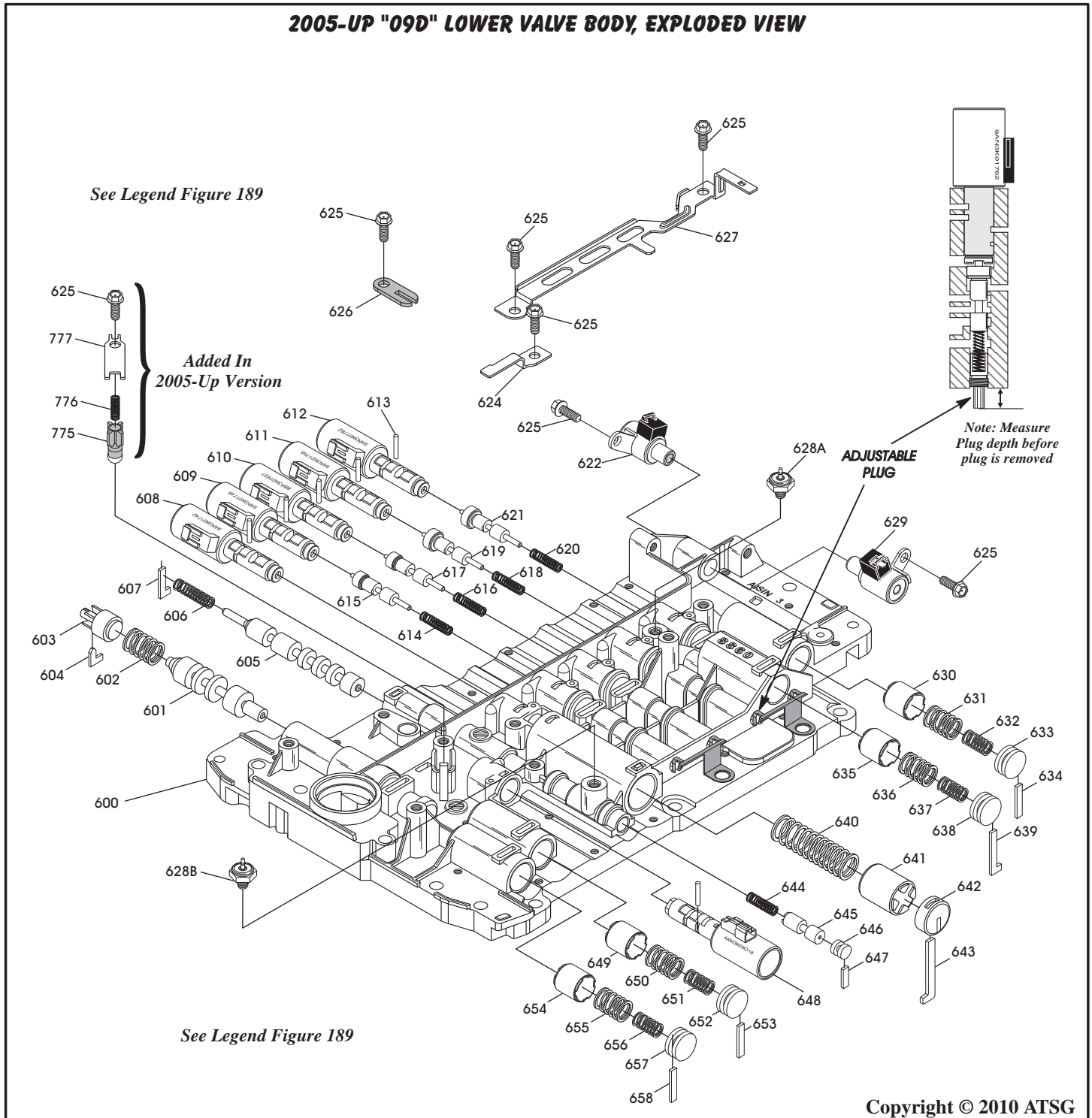

Figure 188



FIGURE 188 AND 191 LEGEND

- 600 LOWER VALVE BODY CASTING.
- 601 SECONDARY PRESSURE REGULATOR VALVE.
- 602 SECONDARY PRESSURE REGULATOR VALVE SPRING (NONE).
- 603 SECONDARY PRESSURE REGULATOR VALVE ADJUSTMENT PLUG.
- 604 SECONDARY PRESSURE REGULATOR VALVE ADJUSTMENT RETAINER.
- 605 NUMBER 1 RELAY VALVE.
- 606 NUMBER 1 RELAY VALVE SPRING (NONE).
- 607 NUMBER 1 RELAY VALVE RETAINER.
- 608 N93 PWM LINE PRESSURE CONTROL SOLENOID.
- 609 N92 PWM K1 CLUTCH CONTROL SOLENOID.
- 610 N90 PWM K3 CLUTCH CONTROL SOLENOID.
- 611 N283 PWM B1 CLUTCH CONTROL SOLENOID.
- 612 N282 PWM K2 CLUTCH CONTROL SOLENOID).
- 613 PWM SOLENOID RETAINER PINS (6 REQUIRED).
- 614 K1 CLUTCH REGULATOR VALVE SPRING (RED).
- 615 K1 CLUTCH REGULATOR VALVE.
- 616 K3 CLUTCH REGULATOR VALVE SPRING (NONE).
- 617 K3 CLUTCH REGULATOR VALVE.
- 618 B1 CLUTCH REGULATOR VALVE SPRING (NONE).
- 619 B1 CLUTCH REGULATOR VALVE.
- 620 K2 CLUTCH REGULATOR VALVE SPRING (NONE).
- 621 K2 CLUTCH REGULATOR VALVE.
- 622 N89 ON/OFF SOLENOID.
- 624 N282 PWM TCC CONTROL SOLENOID PIN RETAINER.
- 625 RETAINING BOLTS, 12 MM (0.472") LONG (7 REQUIRED).
- 626 TRANSMISSION TEMP SENSOR RETAINING BRACKET.
- 627 N93, N90, N92, N283, N282 SOLENOID PIN RETAINER.
- 628A B2 PRESSURE SWITCH (NOT USED IN ALL MODELS).
- 628B K1 PRESSURE SWITCH (NOT USED IN ALL MODELS).
- 629 N88 ON/OFF SOLENOID.
- 630 K2 ACCUMULATOR PISTON.
- 631 K2 ACCUMULATOR PISTON OUTER SPRING (NONE).
- 632 K2 ACCUMULATOR PISTON INNER SPRING (GRAY).
- 633 K2 ACCUMULATOR PISTON BORE PLUG.
- 634 K2 ACCUMULATOR PISTON BORE PLUG RETAINER.
- 635 B1 ACCUMULATOR PISTON.
- 636 B1 ACCUMULATOR PISTON OUTER SPRING (NONE).
- 637 B1 ACCUMULATOR PISTON INNER SPRING (GRAY).
- 638 B1 ACCUMULATOR PISTON BORE PLUG.
- 639 B1 ACCUMULATOR PISTON BORE PLUG RETAINER.
- 640 FORWARD ENGAGEMENT ACCUMULATOR SPRING (NONE).
- 641 FORWARD ENGAGEMENT ACCUMULATOR PISTON.
- 642 FORWARD ENGAGEMENT ACCUMULATOR BORE PLUG.
- 643 FORWARD ENGAGEMENT ACCUMULATOR BORE PLUG RETAINER.
- 644 K1 SWITCH VALVE SPRING (PINK).
- 645 K1 SWITCH VALVE.
- 646 K1 SWITCH BORE PLUG.
- 647 K1 SWITCH BORE PLUG RETAINER.
- 648 N91 PWM TCC CONTROL SOLENOID.
- 649 N93/LINE PRESSURE SOLENOID ACCUMULATOR PISTON.
- 650 N93 ACCUMULATOR PISTON OUTER SPRING (NONE).
- 651 N93 ACCUMULATOR PISTON INNER SPRING (GRAY).
- 652 N93 ACCUMULATOR PISTON BORE PLUG.
- 653 N93 ACCUMULATOR PISTON BORE PLUG RETAINER.
- 654 K3 ACCUMULATOR PISTON.
- 655 K3 ACCUMULATOR PISTON OUTER SPRING (NONE).
- 656 K3 ACCUMULATOR PISTON INNER SPRING (GRAY).
- 657 K3 ACCUMULATOR PISTON BORE PLUG.
- 658 K3 ACCUMULATOR PISTON BORE PLUG RETAINER.
- 659 ROUND SCREENS (OPEN SIDE FACES SPACER PLATE) (2 REQ).
- 660 VALVE BODY SPACER PLATE.
- 661 OVAL SCREEN (OPEN SIDE FACES SPACER PLATE).
- 662 K3 EXHAUST CHECK VALVE, 9.96 MM (.392") DIAMETER.
- 663 K3 EXHAUST CHECK VALVE SPRING (WHITE).
- 664 REGULATED EXHAUST CHECK VALVE, 9.96 MM (.392") DIA.
- 665 REGULATED EXHAUST CHECK VALVE SPRING (WHITE).
- 666 B2 CLUTCH PLASTIC CHECK VALVE ASSEMBLY.
- 667 FORWARD/K2 PLASTIC CHECK VALVE ASSEMBLY.
- 775 TCC APPLY EXHAUST CHECK VALVE ASSEMBLY.
- 776 TCC APPLY EXHAUST CHECK VALVE SPRING.
- 777 TCC APPLY EXHAUST CHECK VALVE RETAINER PLATE.

Figure 189

"UPDATED" VALVE BODY INFORMATION (CONT'D)

SPECIAL NOTE: VALVE NAMES SHOWN WERE ASSIGNED BY ATSG BASED ON THEIR FUNCTION.

LOWER VALVE BODY SPRING SPECIFICATIONS

SPRING NUMBER 602 Free Length = 1.025" Spring Diameter = .640" Wire Diameter = .055" Approx Coils = 6 (NONE)	SPRING NUMBER 620 Free Length = .860" Spring Diameter = .235" Wire Diameter = .032" Approx Coils = 13 (NONE)
SPRING NUMBER 606 Free Length = 1.580" Spring Diameter = .360" Wire Diameter = .025" Approx Coils = 13 (NONE)	SPRINGS 631, 636, 650, 655, Free Length = 1.085" Spring Diameter = .628" Wire Diameter = .082" Approx Coils = 6.5 (NONE)
SPRING NUMBER 614 Free Length = 1.018" Spring Diameter = .235" Wire Diameter = .025" Approx Coils = 14 (RED)	SPRINGS 632, 637, 651, 656, Free Length = 1.093" Spring Diameter = .430" Wire Diameter = .062" Approx Coils = 8.5 (GRAY)
SPRING NUMBER 616 Free Length = .860" Spring Diameter = .235" Wire Diameter = .032" Approx Coils = 13 (NONE)	SPRING NUMBER 640 Free Length = 2.456" Spring Diameter = .775" Wire Diameter = .075" Approx Coils = 10 (NONE)
SPRING NUMBER 618 Free Length = .860" Spring Diameter = .235" Wire Diameter = .032" Approx Coils = 13 (NONE)	SPRING NUMBER 644 Free Length = 1.090" Spring Diameter = .280" Wire Diameter = .025" Approx Coils = 11 (PINK)

LOWER VALVE BODY SPRING SPECIFICATIONS SMALL PARTS, WORM TRACK SIDE

SPRING NO. 663 Free Length = .600" Spring Diameter = .248" Wire Diameter = .023" Approx Coils = 11 (WHITE)	SPRING NO. 665 Free Length = .600" Spring Diameter = .248" Wire Diameter = .023" Approx Coils = 11 (WHITE)
--	--

Copyright © 2010 ATSG

Figure 190

"UPDATED" VALVE BODY ASSEMBLY (CONT'D)

The small parts in the lower valve body have not changed. Their locations and calibrations are exactly the same as previous models and are provided for you in Figure 240. Notice that several of the worm tracks are shaded which depict the improvements that have occurred in the hydraulic system. These improvements also required a change in the spacer plate.

Note: ATSG has available a "Technicians Guide" that includes color hydraulic schematics for each and every gear and identification of all orifices and passages. The 2005-Up valve body hydraulic change is also included in the "Technicians Guide".

Continued on Page 108

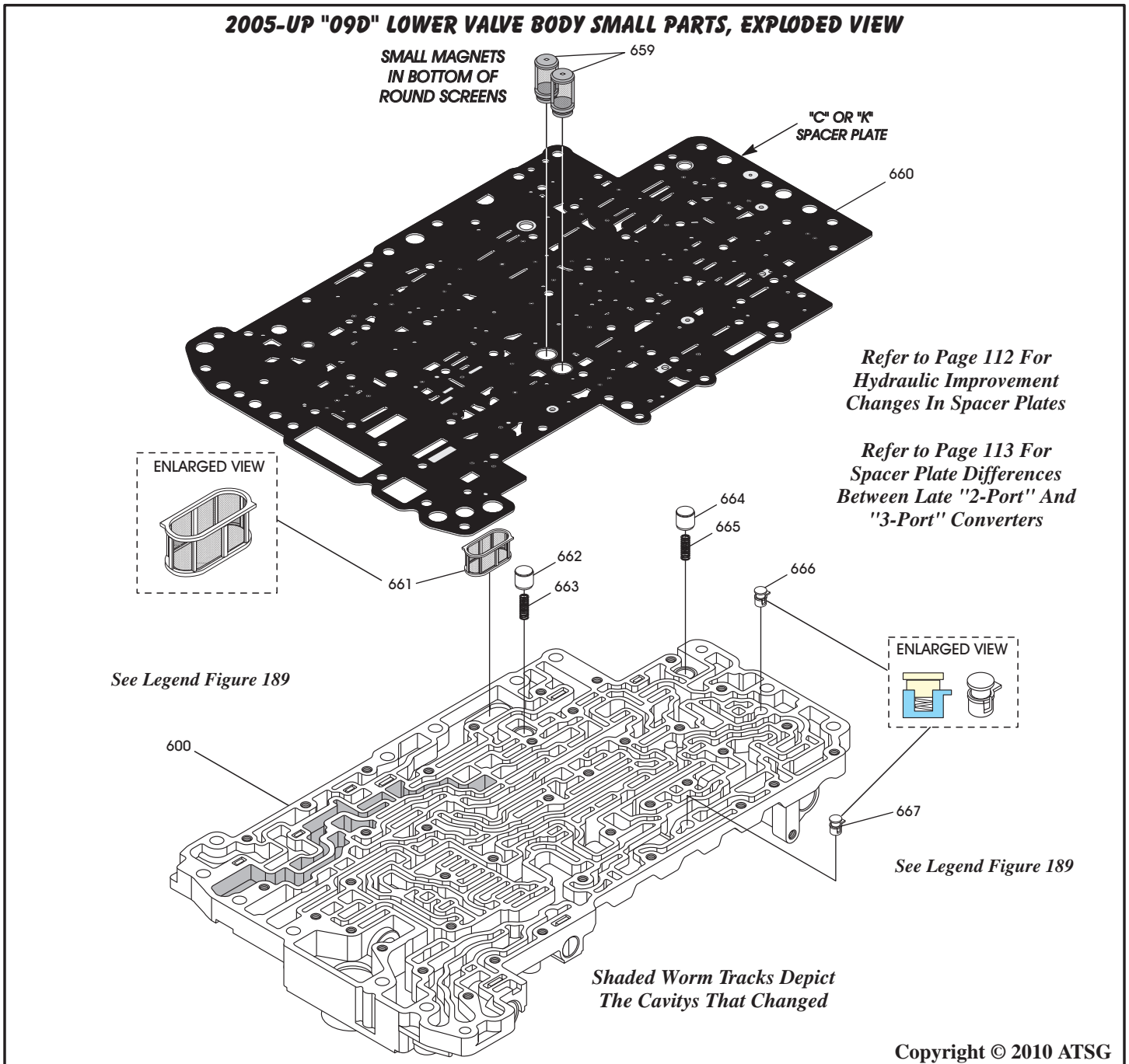

Figure 191

2005-UP "09D" UPPER VALVE BODY EXPLODED VIEW

WWW.ALL-TRANS.BY

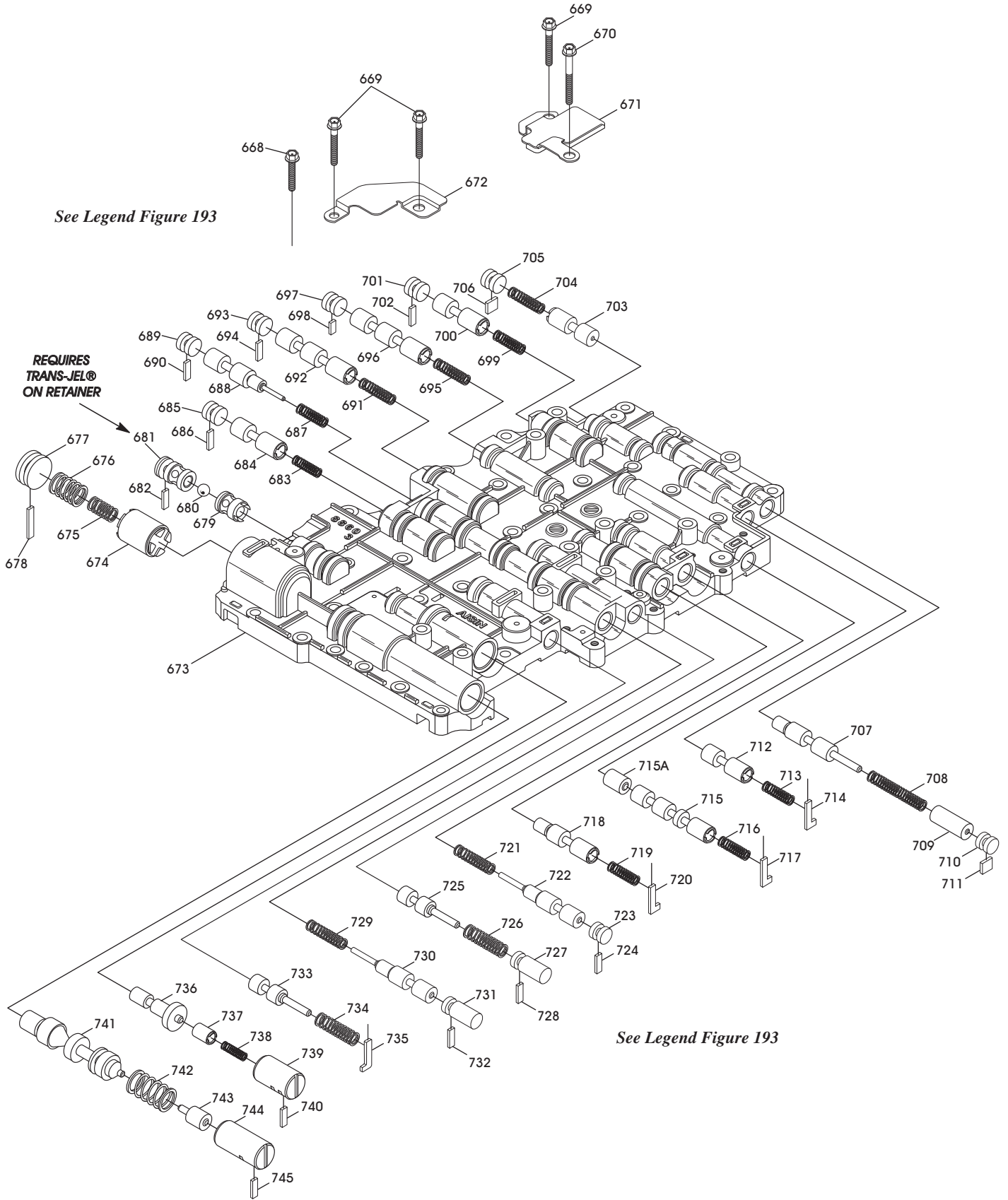

Figure 192



Technical Service Information

"UPDATED" VALVE BODY INFORMATION (CONT'D)

Some small parts in the upper valve body have changed. Their locations and names are provided for you in Figure 194. Notice that two of the check valves are not used with the "K" spacer plate. Spring specifications are provided in Figure 195.

Notice in Figure 194 that several of the worm tracks are shaded which depict the improvements that have occurred in the hydraulic system. These improvements also required a change in the spacer plate.

Continued on Page 111

FIGURE 192 AND 194 LEGEND

- | | |
|--|--|
| 659 ROUND SCREENS (2 REQUIRED). | 720 B2 PORT CONTROL VALVE RETAINER. |
| 660 VALVE BODY SPACER PLATE. | 721 B1 RELAY VALVE SPRING (ORANGE). |
| 668 UPPER VB TO LOWER VB BOLT, 22 MM (.866") (4 REQUIRED). | 722 B1 RELAY VALVE. |
| 669 UPPER VB TO LOWER VB BOLT, 28 MM (1.102") (25 REQUIRED). | 723 B1 RELAY VALVE BORE PIWG. |
| 670 UPPER VB TO LOWER VB BOLT, 40 MM (1.574") (10 REQUIRED). | 724 B1 RELAY VALVE BORE PIWG RETAINER. |
| 671 OIL BAFFLE NUMBER 2. | 725 SOLENOID MODULATOR VALVE B VALVE. |
| 672 OIL BAFFLE NUMBER 1. | 726 SOLENOID MODULATOR VALVE B VALVE SPRING (NONE). |
| 673 UPPER VALVE BODY CASTING. | 727 SOLENOID MODULATOR VALVE B VALVE BORE PLUG. |
| 674 K1 ACCUMULATOR PISTON. | 728 SOLENOID MODULATOR VALVE B VALVE BORE PLUG RETAINER. |
| 675 K1 ACCUMULATOR PISTON INNER SPRING (LT BLUE). | 729 K3 RELAY VALVE SPRING (ORANGE). |
| 676 K1 ACCUMULATOR PISTON OUTER SPRING (NONE). | 730 K3 RELAY VALVE. |
| 677 K1 ACCUMULATOR PISTON BORE PLUG. | 731 K3 RELAY VALVE BORE PIWG. |
| 678 K1 ACCUMULATOR PISTON BORE PLUG RETAINER. | 732 K3 RELAY VALVE BORE PIWG RETAINER. |
| 679 K3/B1 THREE WAY INNER SHUTTLE BALL SEAT. | 733 SOLENOID MODULATOR VALVE A VALVE. |
| 680 SHUTTLE BALL (.250" DIAMETER STEEL). | 734 SOLENOID MODULATOR VALVE A SPRING (NONE). |
| 681 K3/B1 THREE WAY OUTER SHUTTLE BALL SEAT. | 735 SOLENOID MODULATOR VALVE A RETAINER. |
| 682 K3/B1 THREE WAY OUTER SHUTTLE BALL SEAT RETAINER. | 736 TCC APPLY CONTROL VALVE. |
| 683 N283 SWITCH VALVE SPRING (PINK). | 737 TCC APPLY CONTROL BOOST VALVE. |
| 684 N283 SWITCH VALVE. | 738 TCC APPLY CONTROL BOOST VALVE SPRING (TAN). |
| 685 N283 SWITCH VALVE BORE PLUG. | 739 TCC APPLY CONTROL BOOST VALVE SLEEVE. |
| 686 N283 SWITCH VALVE BORE PLUG RETAINER. | 740 TCC APPLY CONTROL BOOST VALVE SLEEVE RETAINER. |
| 687 N90 SWITCH VALVE SPRING (ORANGE). | 741 PRIMARY PRESSURE REGULATOR VALVE. |
| 688 N90 SWITCH VALVE. | 742 PRIMARY PRESSURE REGULATOR VALVE SPRING (PINK). |
| 689 N90 SWITCH VALVE BORE PLUG. | 743 LINE PRESSURE BOOST VALVE. |
| 690 N90 SWITCH VALVE BORE PLUG RETAINER. | 744 LINE PRESSURE BOOST VALVE SLEEVE. |
| 691 K3 CONTROL VALVE SPRING (PINK). | 745 LINE PRESSURE BOOST VALVE SLEEVE RETAINER. |
| 692 K3 CONTROL VALVE. | 746 LUBE CHECK VALVE SPRING (PINK). |
| 693 K3 CONTROL VALVE BORE PLUG. | 747 LUBE CHECK VALVE, 9.98 MM (.392") DIAMETER. |
| 694 K3 CONTROL VALVE BORE PLUG RETAINER. | 748 SECONDARY REG. VALVE PLASTIC CHECK VALVE ASSEMBLY. |
| 695 B1 CONTROL VALVE SPRING (PINK). | 749 TCC APPLY LIMIT CHECK VALVE SPRING (VIOLET). |
| 696 B1 CONTROL VALVE. | 750 TCC APPLY LIMIT CHECK VALVE, 9.98 MM (.392") DIAMETER. |
| 697 B1 CONTROL VALVE BORE PLUG. | 751 N93 SOLENOID LIMIT CHECK VALVE SPRING (LT BLUE). |
| 698 B1 CONTROL VALVE BORE PLUG RETAINER. | 752 N93 SOLENOID LIMIT CHECK VALVE, 11.98 MM (.471") DIAMETER. |
| 699 K2 CONTROL VALVE SPRING (PINK). | 753 REVERSE LIMIT CHECK VALVE SPRING (WHITE). |
| 700 K2 CONTROL VALVE. | 754 REVERSE LIMIT CHECK VALVE, 9.98 MM (.392") DIAMETER. |
| 701 K2 CONTROL VALVE BORE PLUG. | 755 REVERSE ORIFICE PLASTIC CHECK BALL, 5.5 MM (.217") DIA. |
| 702 K2 CONTROL VALVE BORE PLUG RETAINER. | 756 LINE PRESSURE LIMIT CHECK VALVE SPRING (NONE). |
| 703 B2 SWITCH VALVE (MANUAL "1") VALVE. | 757 LINE PRESSURE LIMIT CHECK VALVE, 9.98 MM (.392") DIAMETER. |
| 704 B2 SWITCH VALVE (MANUAL "1") SPRING (WHITE). | 758 REGULATED EXHAUST CHECK VALVE SPRING (WHITE). |
| 705 B2 SWITCH VALVE (MANUAL "1") BORE PLUG. | 759 REGULATED EXHAUST CHECK VALVE, 9.98 MM (.392") DIAMETER. |
| 706 B2 SWITCH VALVE (MANUAL "1") BORE PLUG RETAINER. | 760 B2 "SMALL" CAVITY PLASTIC CHECK BALL, 5.5 MM (.217") DIA. |
| 707 B2 REGULATOR VALVE. | 761 LUBE RELIEF CHECK VALVE, 9.98 MM (.392") DIAMETER. |
| 708 B2 REGULATOR VALVE SPRING (VIOLET). | 762 LUBE RELIEF CHECK VALVE SPRING (RED). |
| 709 B2 REGULATOR PLUNGER. | 763 K2 CLUTCH PLASTIC CHECK VALVE ASSEMBLY. |
| 710 B2 REGULATOR VALVE BORE PLUG. | 764 B1 CLUTCH PLASTIC CHECK VALVE ASSEMBLY. |
| 711 B2 REGULATOR VALVE BORE PLUG RETAINER. | 765 K3 CLUTCH PLASTIC CHECK VALVE ASSEMBLY. |
| 712 PRESSURE MODIFIER VALVE. | 766 K1 CLUTCH PLASTIC CHECK VALVE ASSEMBLY. |
| 713 PRESSURE MODIFIER SPRING (WHITE). | 767 DRIVE RANGE ORIFICE PLASTIC CHECK BALL, 6.35 MM (.250") DIA. |
| 714 PRESSURE MODIFIER RETAINER. | 768 COOLER CHECK VALVE. |
| 715A NUMBER 2 RELAY VALVE PIWG. | 769 COOLER CHECK VALVE SPRING (TAN). |
| 715 NUMBER 2 RELAY VALVE. | 770 MANUAL VALVE. |
| 716 NUMBER 2 RELAY VALVE SPRING (WHITE). | 771 MANUAL VALVE BODY CASTING. |
| 717 NUMBER 2 RELAY VALVE RETAINER. | 772 MANUAL VALVE BODY RETAINING BOLT 38 MM (1.496") (7 REQ). |
| 718 B2 PORT CONTROL VALVE. | |
| 719 B2 PORT CONTROL VALVE SPRING (WHITE). | |

SPECIAL NOTE: VALVE NAMES SHOWN WERE ASSIGNED BY ATSG BASED ON THEIR FUNCTION.

Copyright © 2010 ATSG

Figure 193

2005-UP "09D" UPPER VALVE BODY SMALL PARTS, EXPLODED VIEW

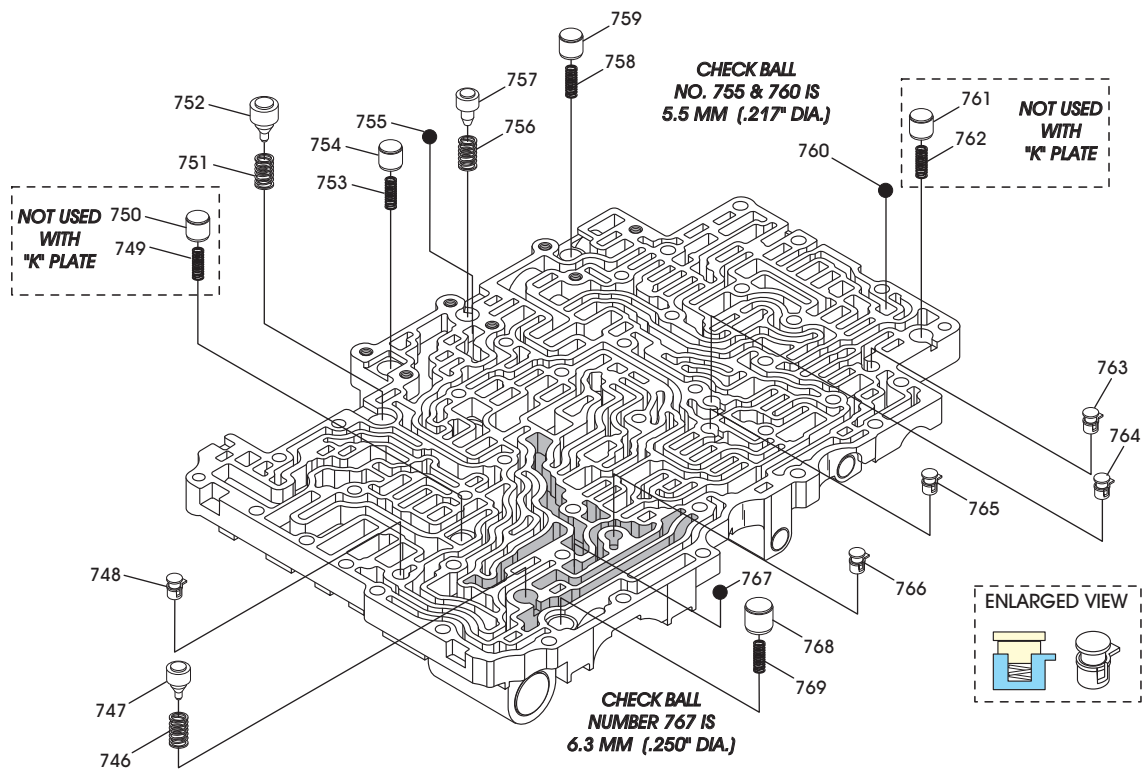
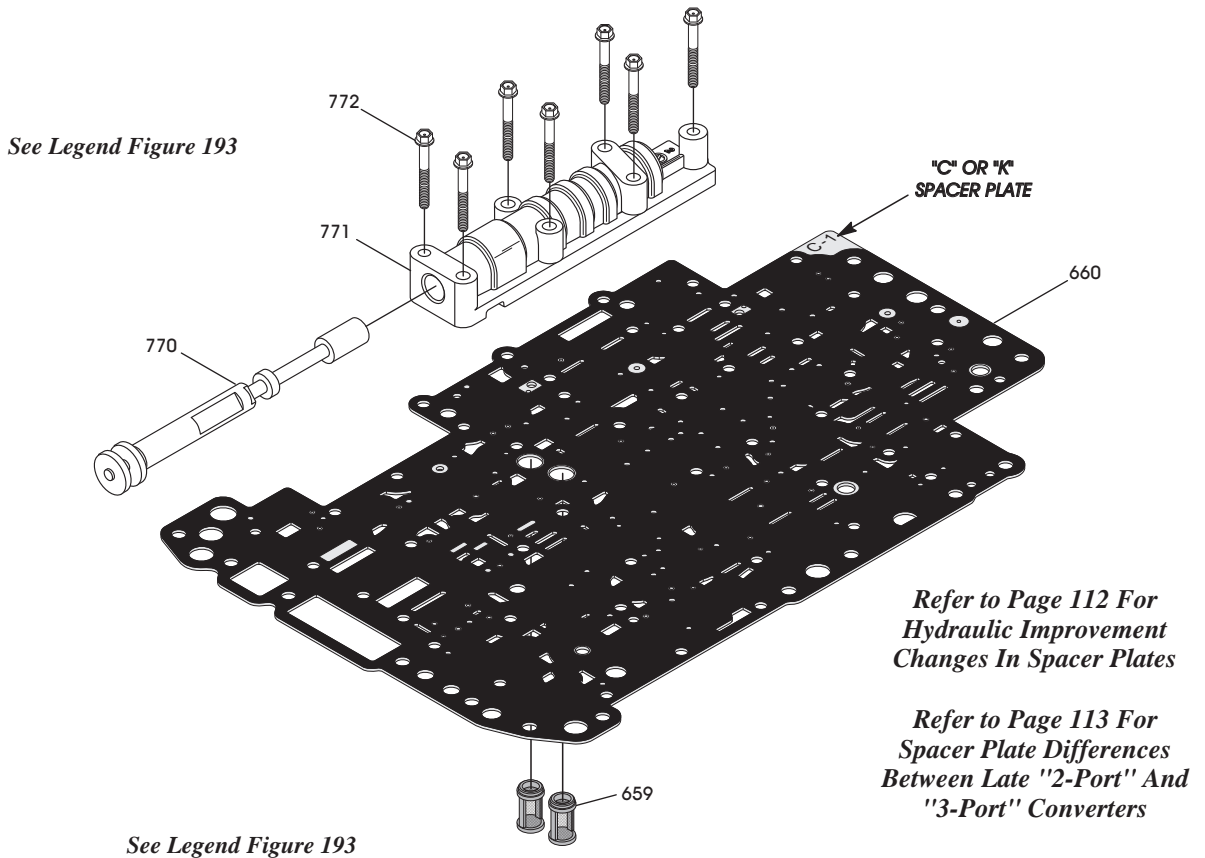

Copyright © 2010 ATSG

Figure 194

2005-UP "09D" UPPER VALVE BODY SPRING SPECIFICATIONS

2006 UPPER VB SPRING SPECIFICATIONS

<p>SPRING NUMBER 675 Free Length = 1.070" Spring Diameter = .425" Wire Diameter = .062" Approx Coils = 9 (LT BLUE)</p>	<p>SPRING NUMBER 708 Free Length = 1.280" Spring Diameter = .275" Wire Diameter = .027" Approx Coils = 21 (VIOLET)</p>
<p>SPRING NUMBER 676 Free Length = 1.090" Spring Diameter = .625" Wire Diameter = .080" Approx Coils = 6 (NONE)</p>	<p>SPRING NUMBER 738 Free Length = .750" Spring Diameter = .220" Wire Diameter = .028" Approx Coils = 12 (TAN)</p>
<p>SPRING NUMBER 683, 691, 695, AND 699. Free Length = 1.060" Spring Diameter = .270" Wire Diameter = .025" Approx Coils = 10 (PINK)</p>	<p>SPRING NUMBER 726, 734, Free Length = 1.425" Spring Diameter = .336" Wire Diameter = .048" Approx Coils = 14 (NONE)</p>
<p>SPRING NUMBER 687, 721, 729, Free Length = 1.130" Spring Diameter = .255" Wire Diameter = .027" Approx Coils = 13 (ORANGE)</p>	<p>SPRING NUMBER 742 Free Length = 1.215" Spring Diameter = .538" Wire Diameter = .049" Approx Coils = 6 (PINK)</p>
<p>SPRING NUMBER 704, 713, 716, AND 719. Free Length = 1.125" Spring Diameter = .295" Wire Diameter = .029" Approx Coils = 12 (WHITE)</p>	

UPPER VALVE BODY SPRING SPECIFICATIONS SMALL PARTS, WORM TRACK SIDE

<p>SPRING NO. 746 Free Length = .685" Spring Diameter = .346" Wire Diameter = .042" Approx Coils = 6 (PINK)</p>	<p>SPRING NO. 756 Free Length = .430" Spring Diameter = .373" Wire Diameter = .050" Approx Coils = 4 (NONE)</p>
<p>SPRING NO. 749 Free Length = .610" Spring Diameter = .249" Wire Diameter = .029" Approx Coils = 7 (VIOLET)</p>	<p>SPRING NO. 758 Free Length = .600" Spring Diameter = .248" Wire Diameter = .023" Approx Coils = 11 (WHITE)</p>
<p>SPRING NO. 751 Free Length = .700" Spring Diameter = .407" Wire Diameter = .035" Approx Coils = 6 (LT. BLUE)</p>	<p>SPRING NO. 762 Free Length = .625" Spring Diameter = .250" Wire Diameter = .033" Approx Coils = 8 (RED)</p>
<p>SPRING NO. 753 Free Length = .600" Spring Diameter = .248" Wire Diameter = .023" Approx Coils = 11 (WHITE)</p>	<p>SPRING NO. 769 Free Length = .672" Spring Diameter = .274" Wire Diameter = .019" Approx Coils = 10 (TAN)</p>

Copyright © 2010 ATSG

Figure 195

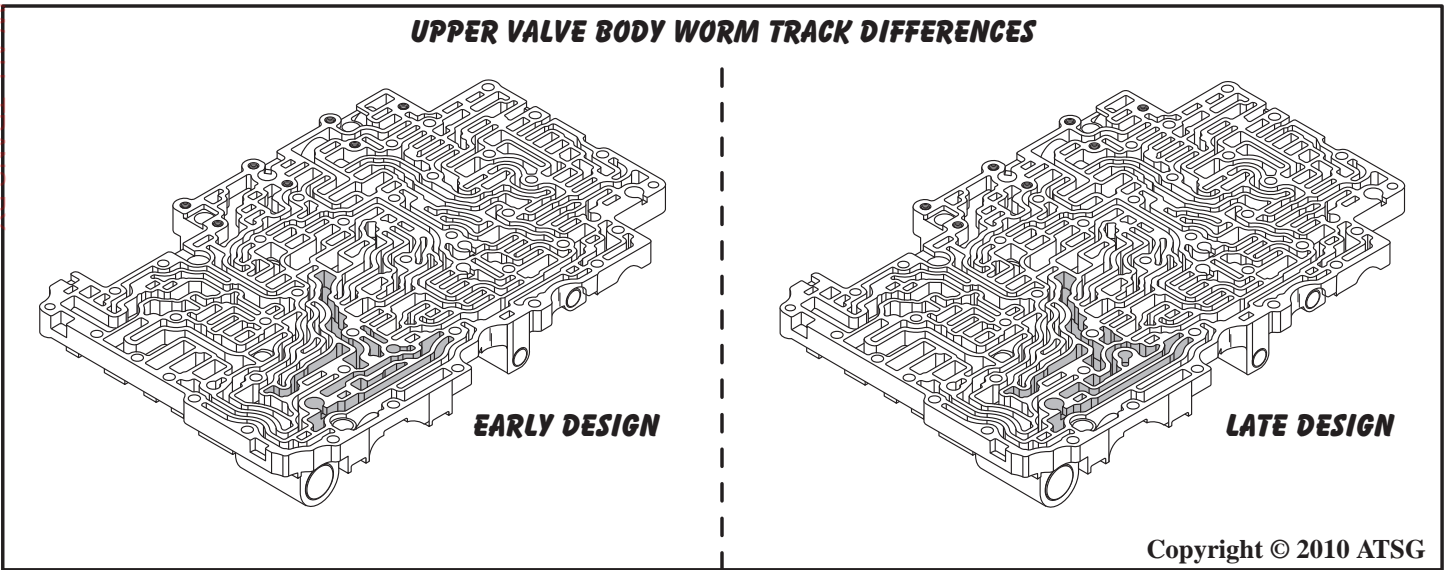

Figure 196

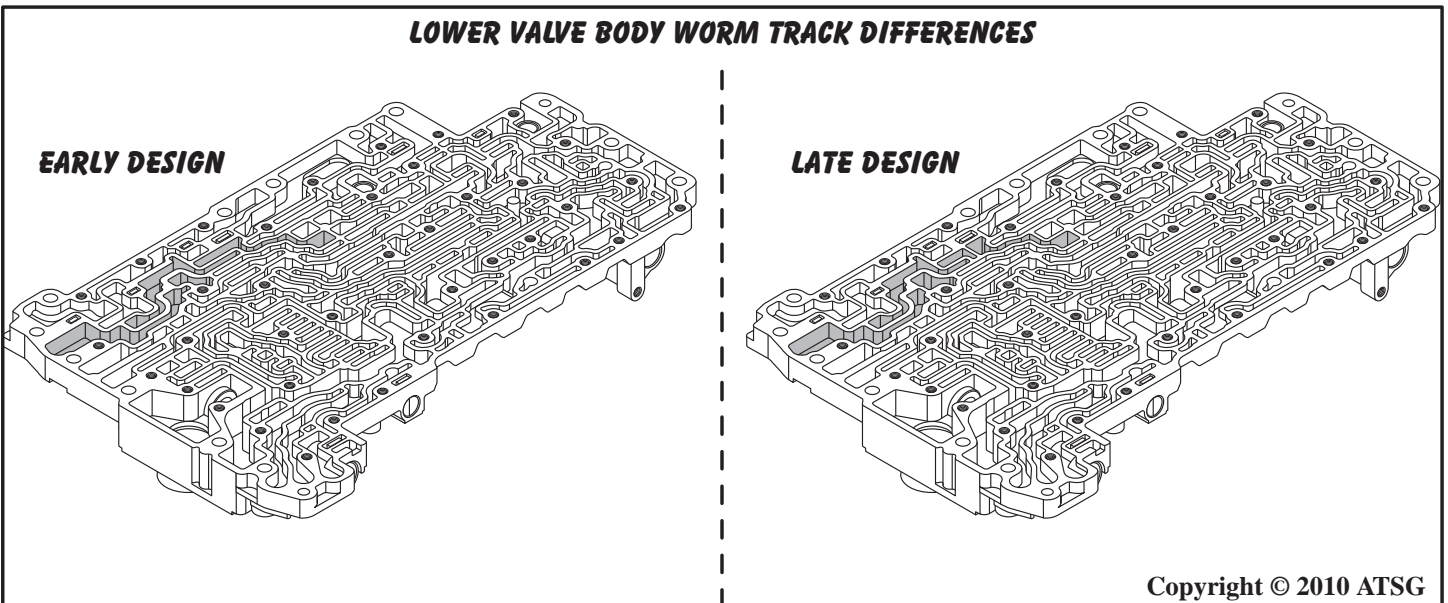

Figure 197

"UPDATED" VALVE BODY INFORMATION (CONT'D)

We have provided you with the early and late style upper valve bodies side by side in Figure 196, with the worm tracks that changed shaded, as another means of identification.

We have provided you with the early and late style lower valve bodies side by side in Figure 197, with the worm tracks that changed shaded, as another means of identification.

Continued on Page 112

"UPDATED" VALVE BODY INFORMATION (CONT'D)

The changes in the hydraulic circuits also required a change in all of the spacer plates, as shown in Figure 198. The holes that are different are "shaded-in" with a "dashed-circle" around the affected holes.

The early version spacer plate is identified with an "A-3" stamped into the plate and the 2005-Up version spacer plate is identified with "C-1" stamped into the plate, as shown in Figure 198.

These Spacer Plates "Will Not" Interchange!

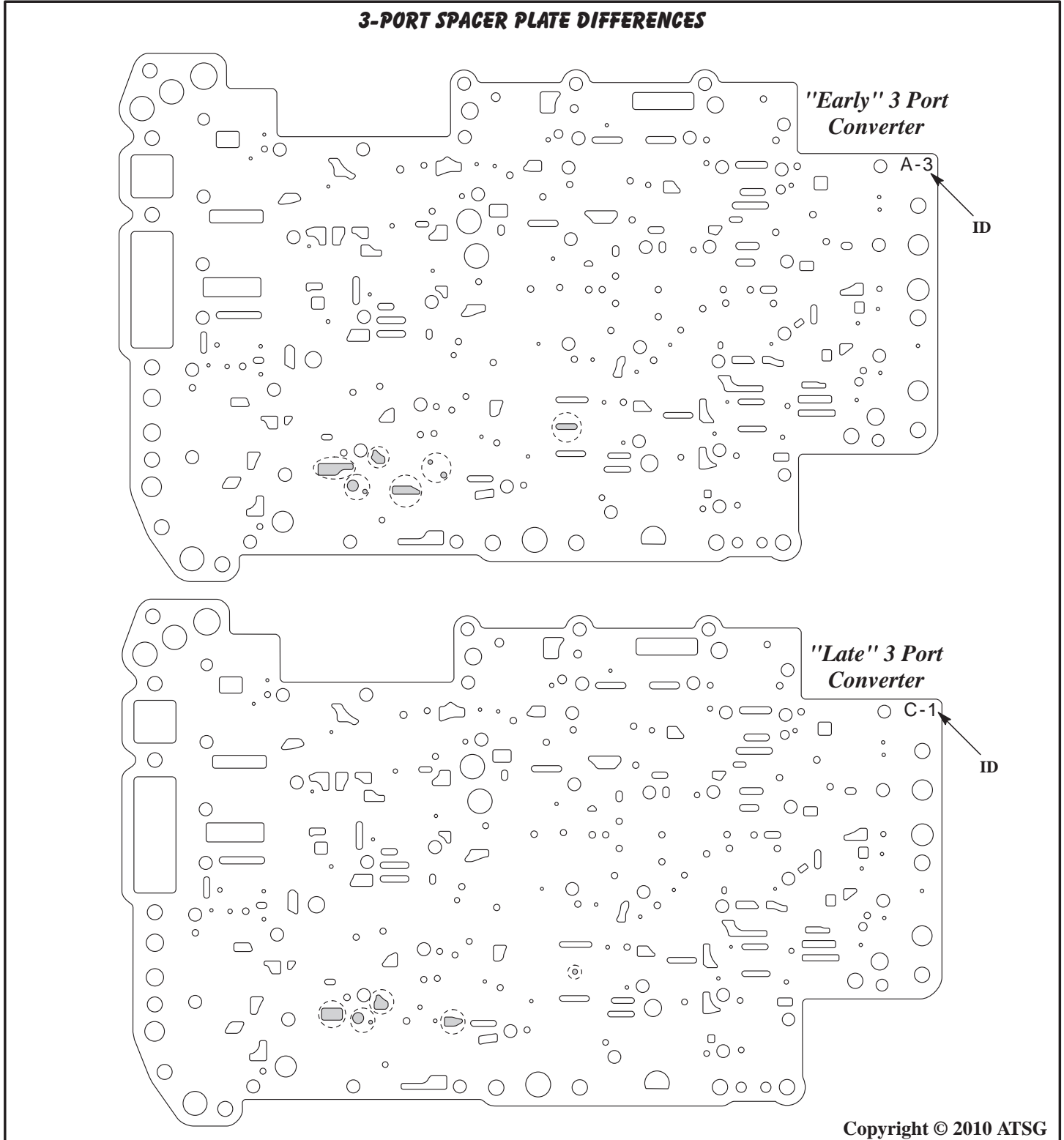

Figure 198

SPACER PLATE DIFFERENCES

The "new design" valve body spacer plates are different between the "2-Port" and "3-Port" torque converters. There are several holes that are in different locations on each of the spacer plates. The holes that are different are "shaded-in" with a "dashed-circle" around the affected holes.

The valve body spacer plates are also identified as to which is the "2-Port" and which is the "3-Port" design and illustrated in Figure 199 below.

These Spacer Plates "Will Not" Interchange!

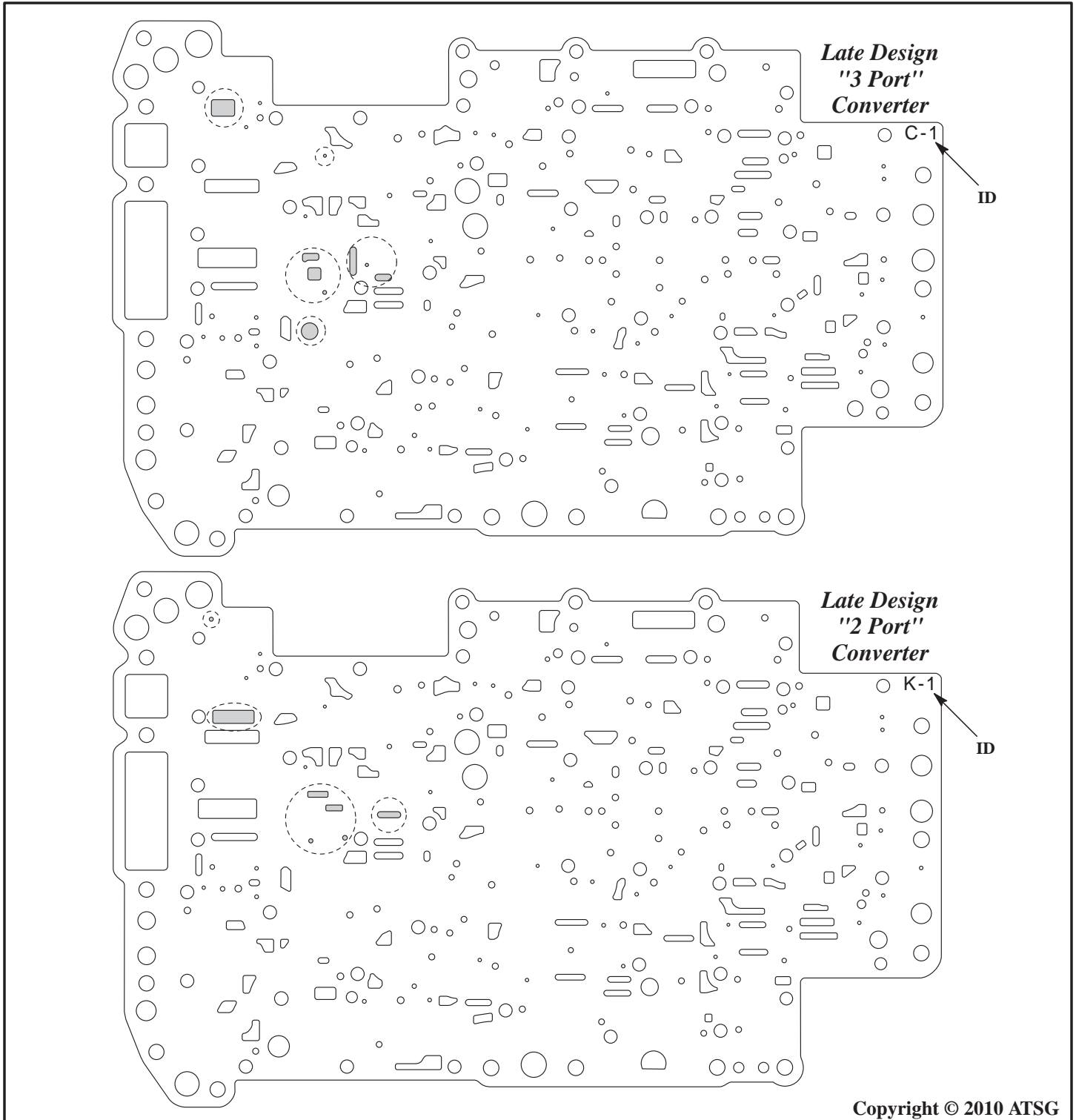

Copyright © 2010 ATSG

Figure 199

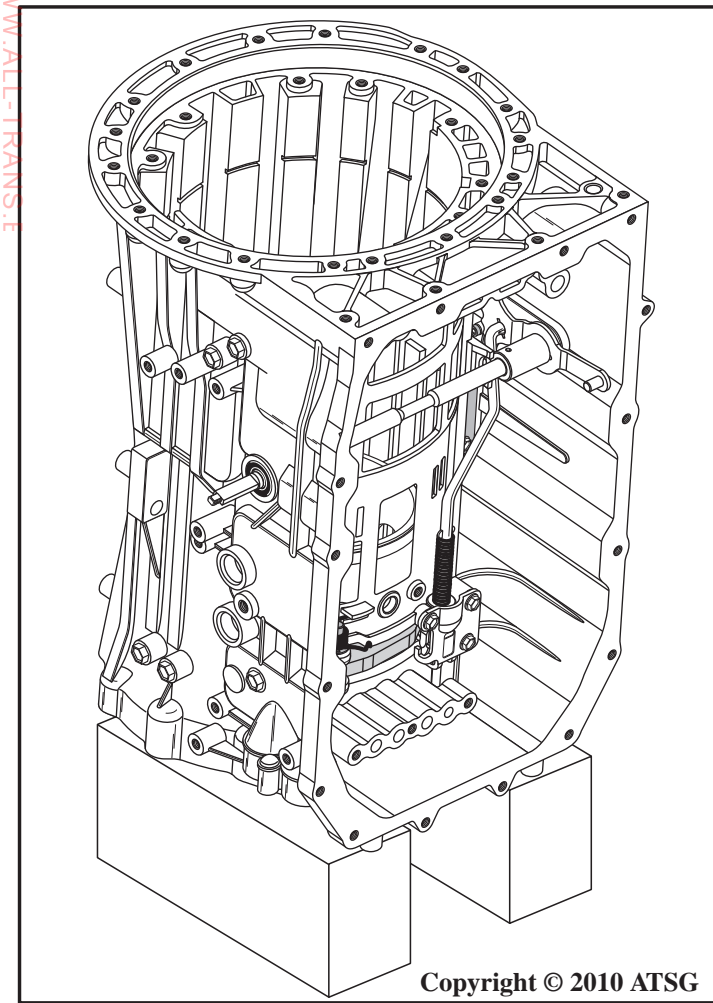

Figure 200

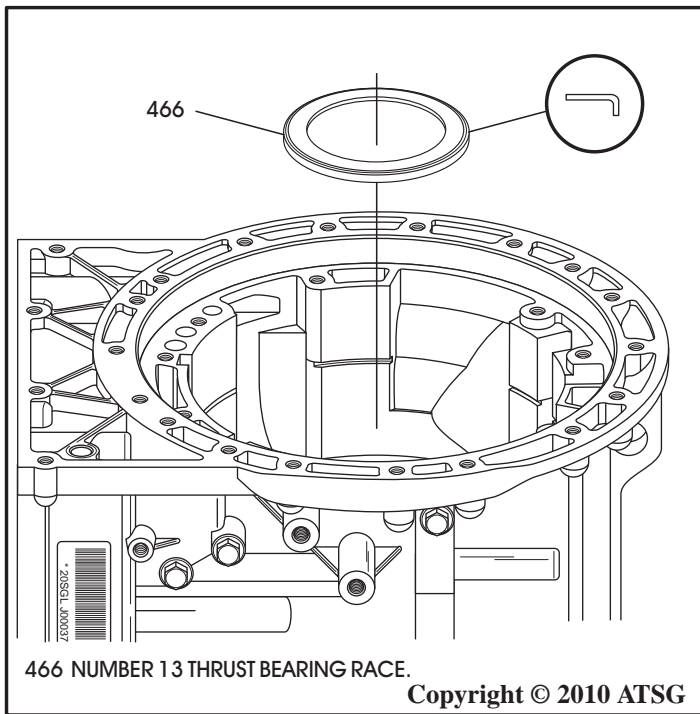

Figure 201

TRANSMISSION ASSEMBLY

1. For transmission assembly we found the easiest method was to place two 4" X 6" blocks on the floor and set the completed transmission case assembly on top, as shown in Figure 200.
2. Ensure that the number 13 thrust bearing race is still installed in case, as shown in Figure 201.
3. Ensure that the number 13 thrust bearing is still installed on output shaft (See Figure 202).
4. Ensure that the number 11 thrust bearing and the number 11 rear race is still installed in K2 clutch housing, as shown in Figure 202.

Continued on Page 115

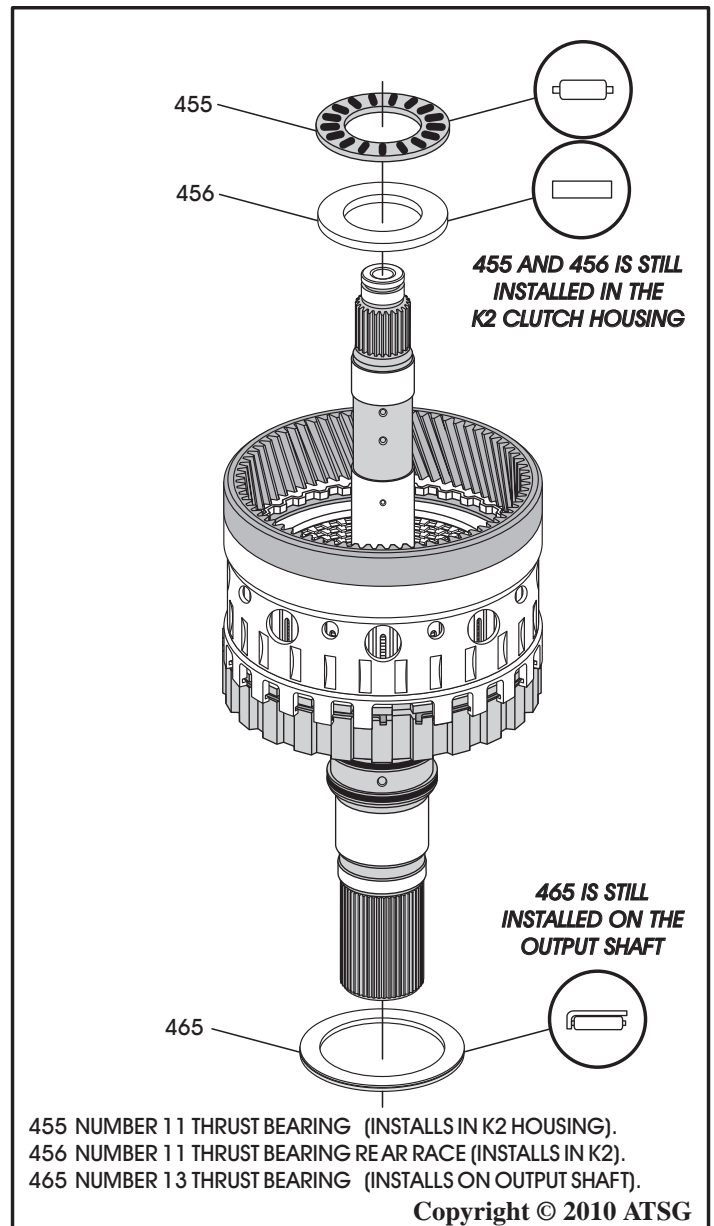

Figure 202

TRANSMISSION ASSEMBLY (CONT'D)

5. Lubricate the output shaft seals and seal surface in case with small amount of Trans-Jel®, and install the completed rear ring gear, output shaft and K2 clutch housing, as shown in Figure 203.
6. The entire B2 clutch pack must be *temporarily* installed, as shown in Figure 204, to verify the B2 clutch clearance.

Continued on Page 116

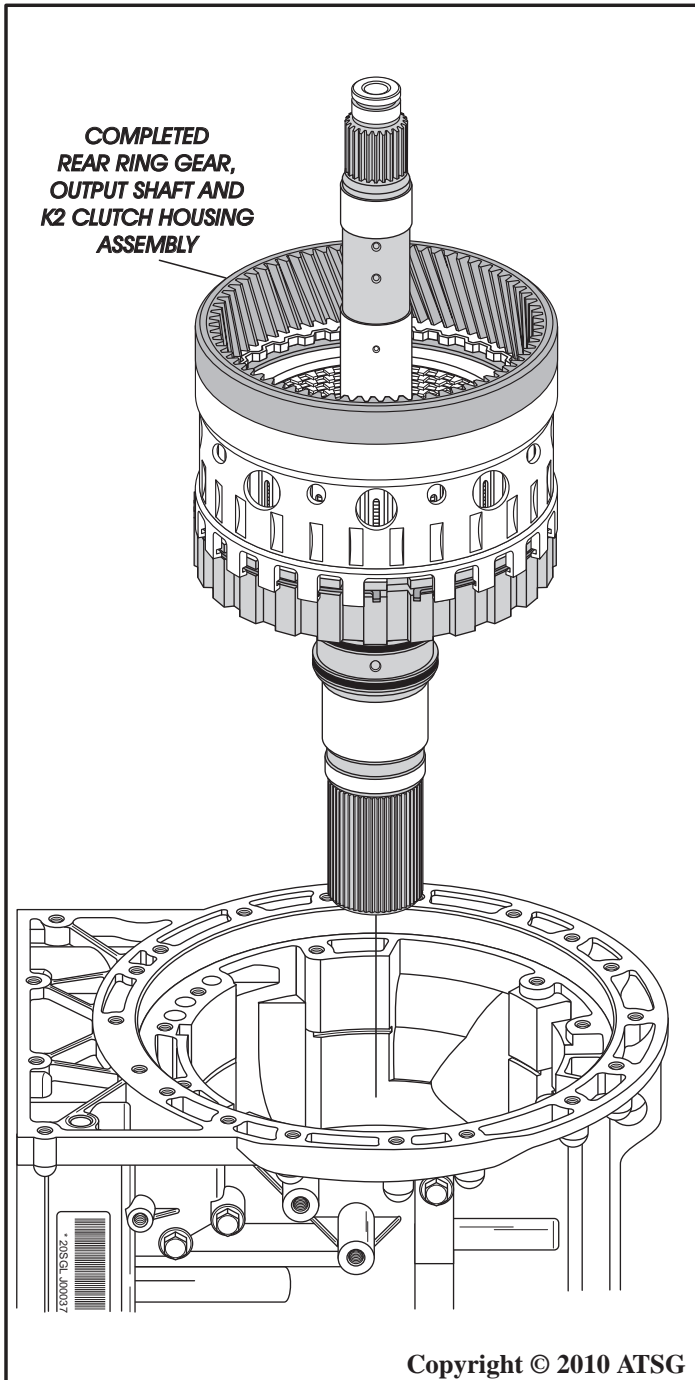

Figure 203

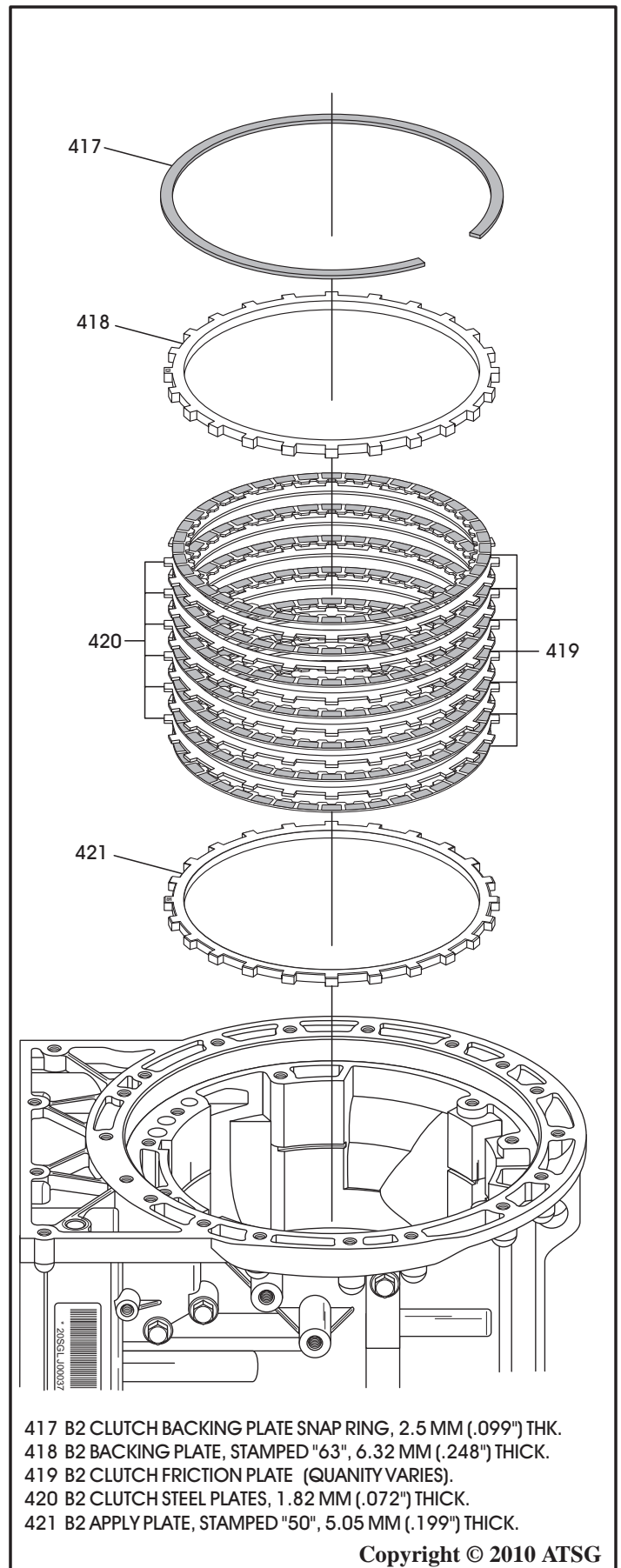

Figure 204

TRANSMISSION ASSEMBLY (CONT'D)

7. Install the B2 clutch apply plate, as shown in Figure 204, with the "rounded" edge facing up towards the friction, as shown in Figure 205.
8. Install B2 clutch plates beginning with a friction and alternating with the steel plates, as shown in Figure 204, until you have the proper amount installed as quantity may vary.

Note: All friction plates should be soaked in proper fluid for 30 minutes before installing.

9. Install the B2 clutch backing plate, as shown in Figure 204, with "rounded" edge facing down toward the last friction, as shown in Figure 205.
10. Install the B2 clutch backing plate snap ring, as shown in Figure 204, and ensure fully seated.
11. Measure the B2 clutch clearance using a feeler gauge between the backing plate and friction plate, as shown in Figure 206.

Note: There are no factory clutch clearance specifications available, but the clearances were the "traditional" .010" per friction plate through-out this unit.

12. B2 clutch clearance should be approximately .010" per friction plate installed, as shown in Figure 206.
13. After verification of the B2 clutch clearance, **remove** the entire B2 clutch pack.

Continued on Page 117

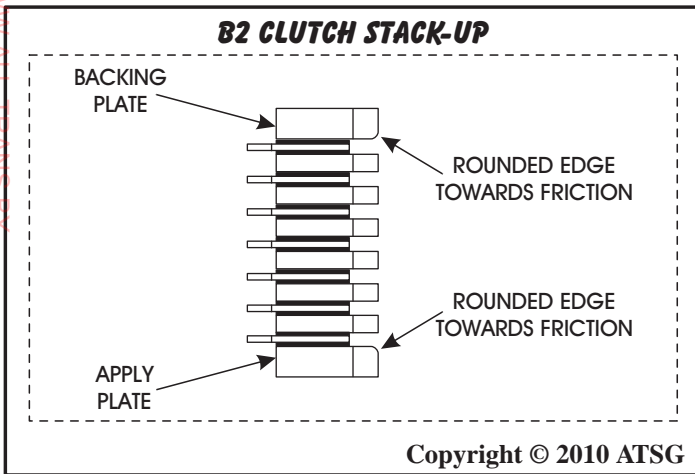

Figure 205

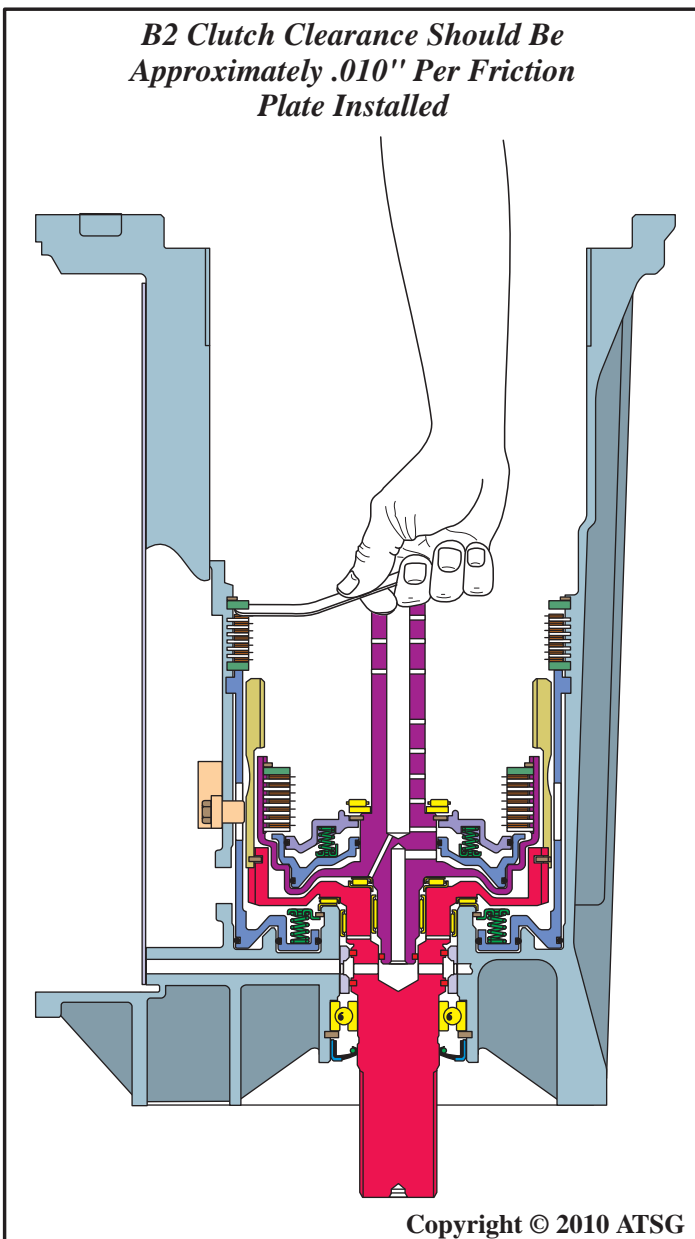

Figure 206

TRANSMISSION ASSEMBLY (CONT'D)

14. Ensure that number 11 thrust bearing front race is still stuck to the back side of planetary carrier, as shown in Figure 207.
15. Ensure that number 10 thrust bearing is installed inside of the rear planetary carrier, as shown in Figure 207.
16. Install completed rear planetary carrier into case, as shown in Figure 207, by rotating to engage the pinion gears into ring gear and rotate back and forth to engage each of the K2 friction plates on rear planetary carrier hub until fully seated.
17. Re-install the entire B2 clutch pack using steps 7 thru 10 on Page 116.

18. Install completed F1 sprag assembly, as shown in Figure 208.
- Note: Lugs on outer race must engage slots in case and splines on inner race must engage the splines on rear planetary carrier.**
19. Install outer race to case snap ring, as shown in Figure 208, and ensure it is fully seated in case.
 20. Install inner race to planetary carrier snap ring, as shown in Figure 208, and ensure it is fully seated in planetary carrier.

Continued on Page 118

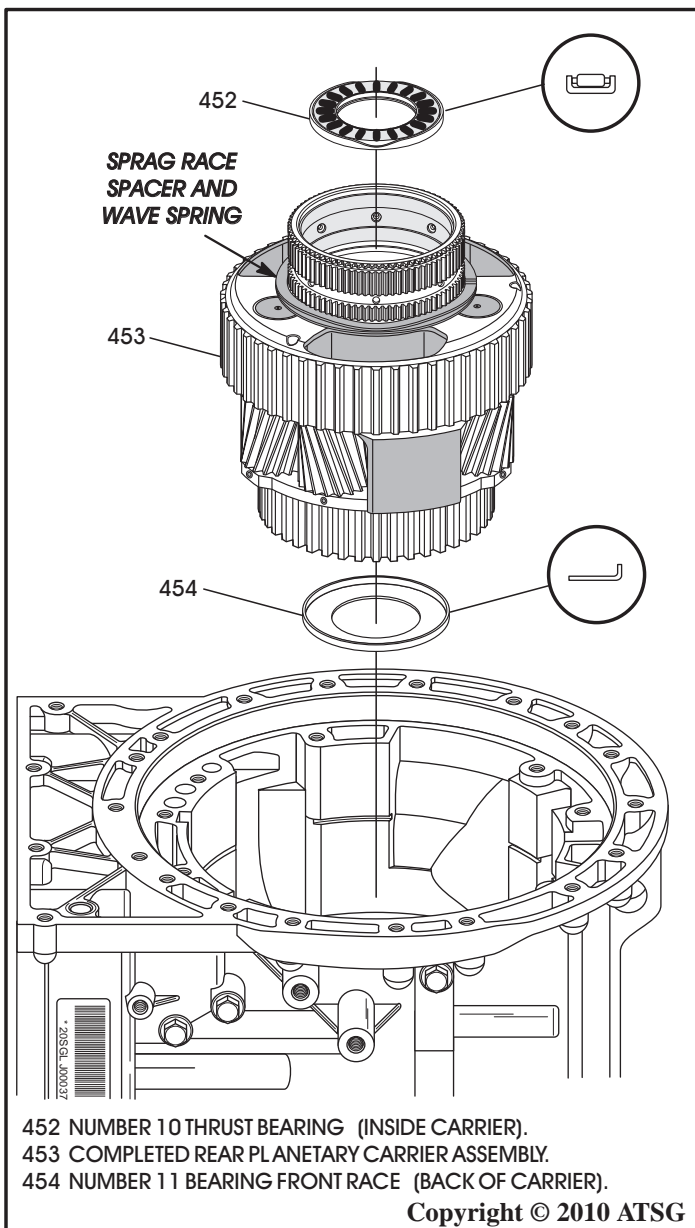

Figure 207

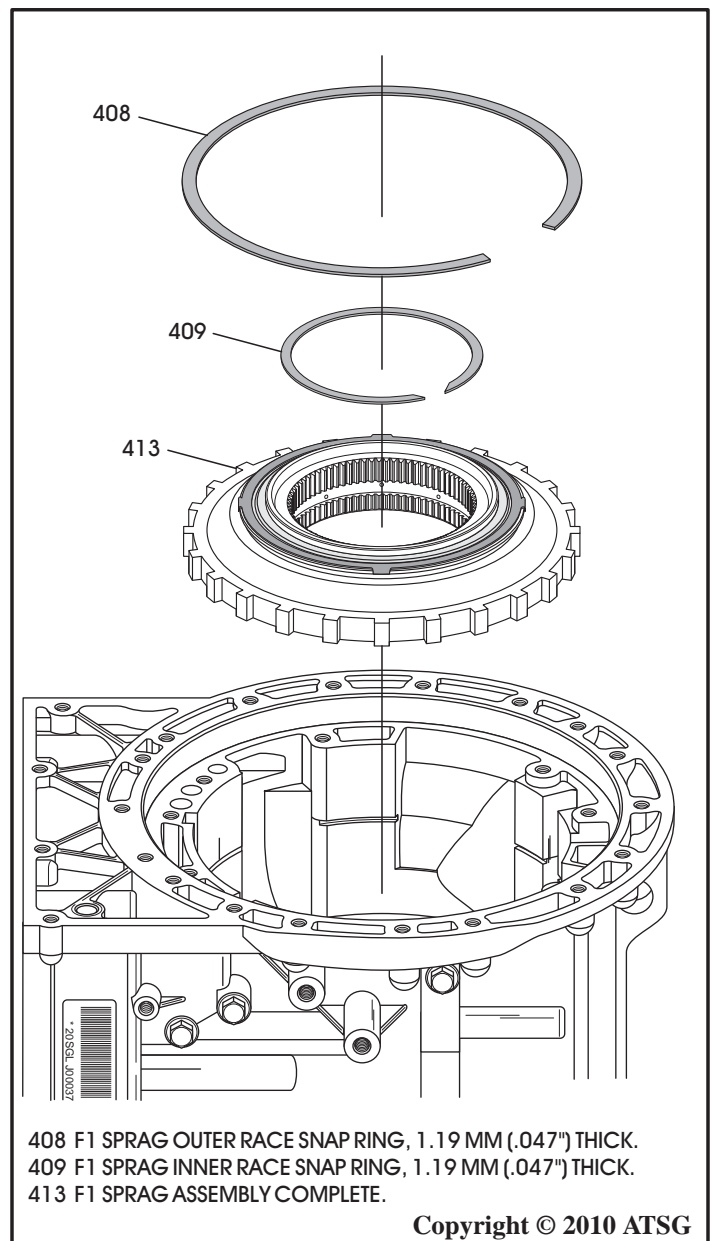
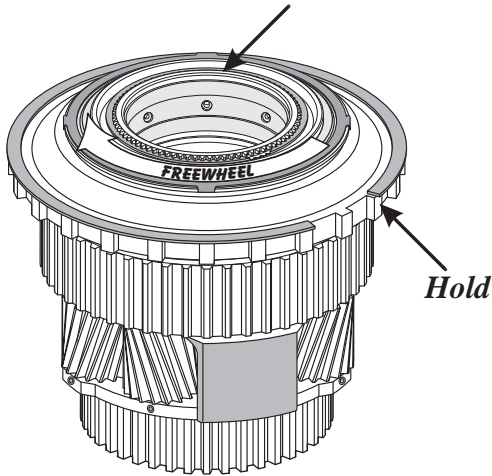

Figure 208

Planetary Carrier And Sprag Inner Race Should Freewheel Clock-Wise



Copyright © 2010 ATSG

Figure 209

TRANSMISSION ASSEMBLY (CONT'D)

21. After installation and both snap rings are fully seated, planetary carrier and sprag inner race should freewheel in a clockwise direction, as shown in Figure 209.
22. Ensure number 10 thrust bearing race is still stuck to bottom of small rear sun gear, as shown in Figure 210, and install sun gear into the rear planetary carrier.
23. Install the number 9 thrust bearing race onto the rear planetary carrier, as shown in Figure 211.
24. Ensure number 9 thrust bearing is still stuck to back of large sun gear and shell, as shown in Figure 211, and install the large sun gear into planetary carrier by rotating into position.

Continued on Page 119

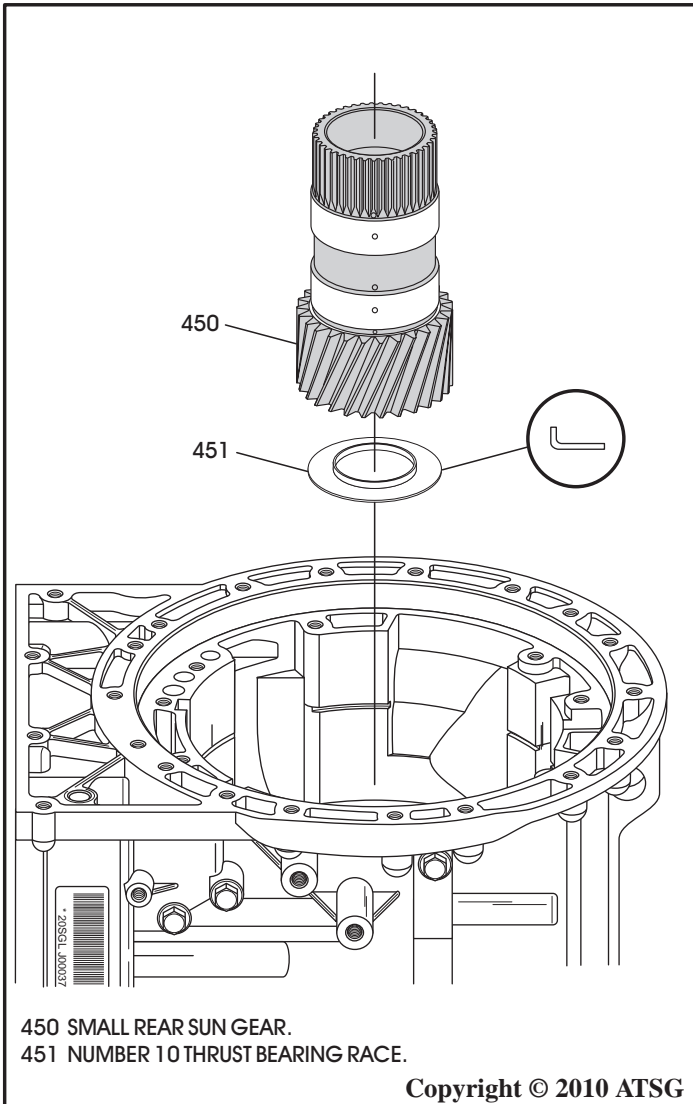

450 SMALL REAR SUN GEAR.
451 NUMBER 10 THRUST BEARING RACE.

Copyright © 2010 ATSG

Figure 210

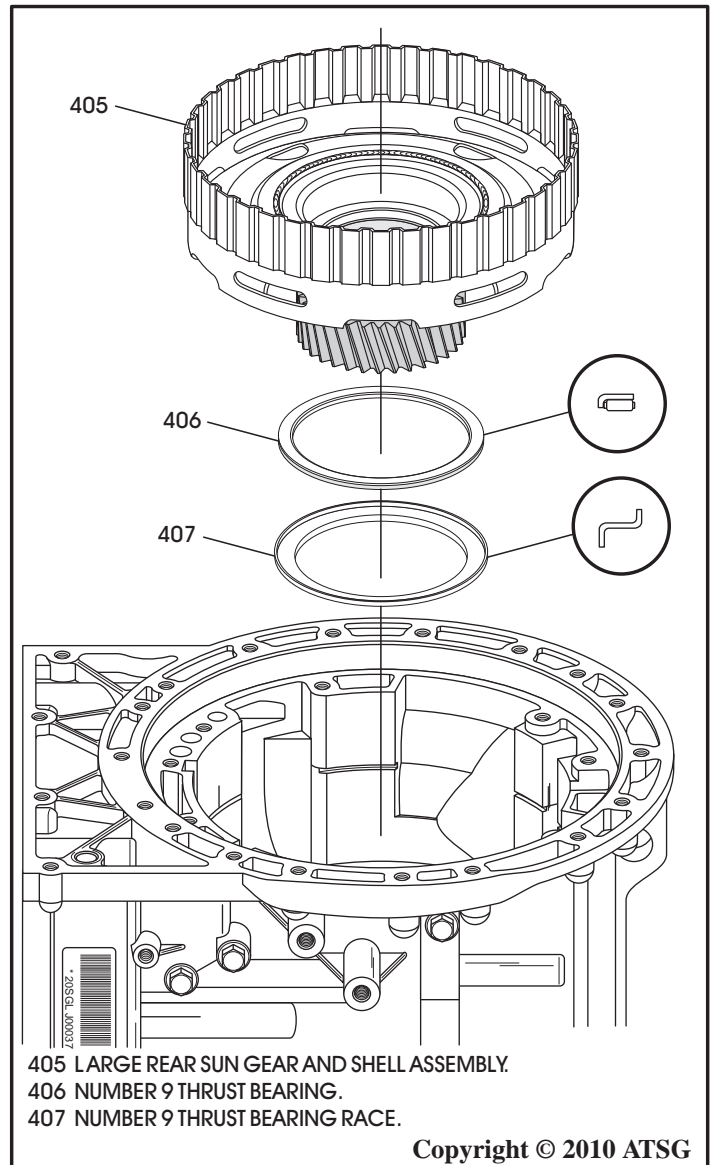

405 LARGE REAR SUN GEAR AND SHELL ASSEMBLY.
406 NUMBER 9 THRUST BEARING.
407 NUMBER 9 THRUST BEARING RACE.

Copyright © 2010 ATSG

Figure 211

TRANSMISSION ASSEMBLY (CONT'D)

25. Install the number 8 thrust bearing, as shown in Figure 212, on top of large sun gear and shell.
26. Ensure the number 8 thrust bearing race is still stuck to the back of K1 clutch hub, as shown in Figure 212, and install K1 clutch hub assembly.
27. Install number 7 thrust bearing race, as shown in Figure 212, in center of installed K1 clutch hub.
28. Ensure the number 7 thrust bearing is still stuck to the back side of K1 clutch housing, as shown in Figure 213.

29. Install completed K1 clutch housing, as shown in Figure 213, by rotating back and forth so the friction plates engage the clutch hub.

Note: Ensure K1 clutch housing is fully seated.
30. Install the number 6 thrust bearing race into the pocket on top of K1 clutch housing, as shown in Figure 213.

Continued on Page 120

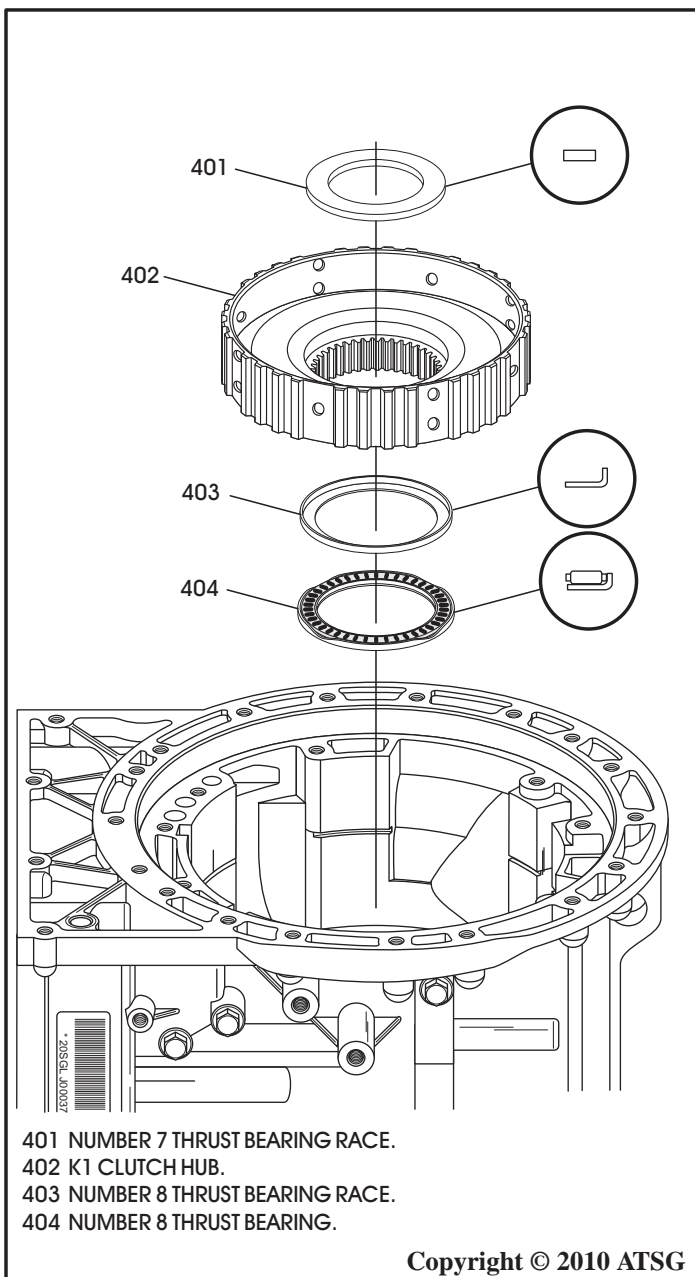

Figure 212

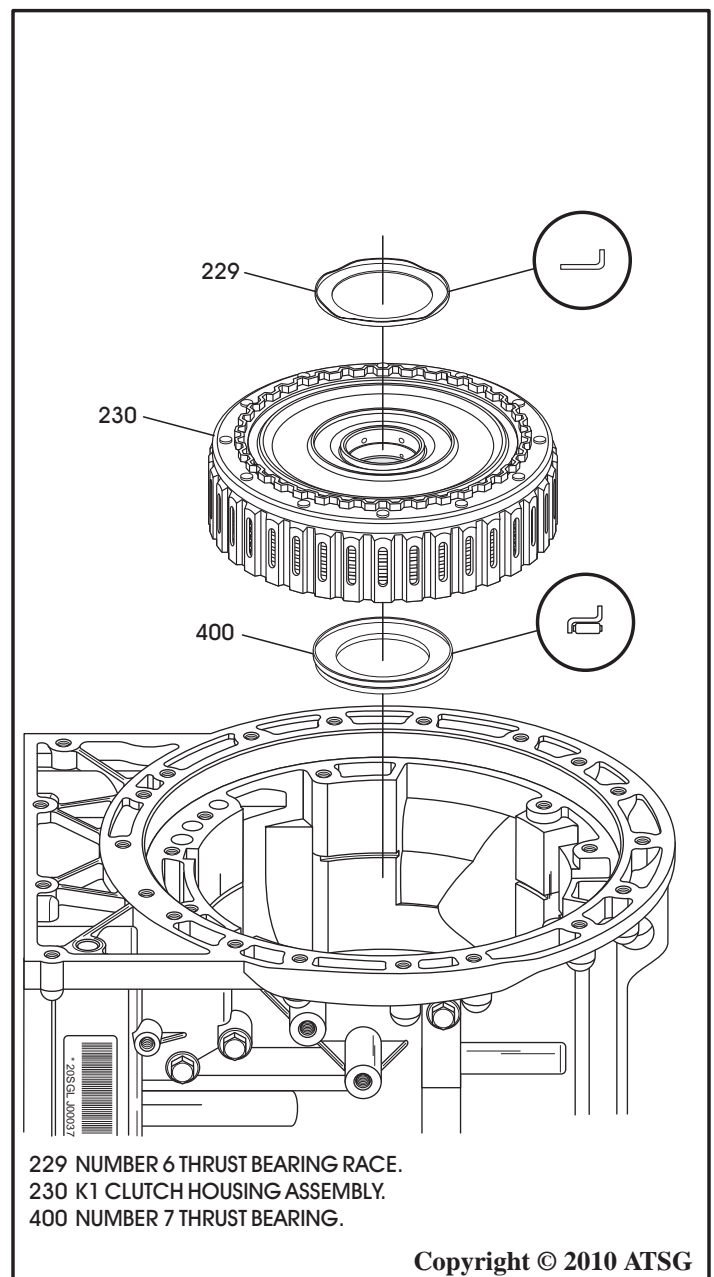

Figure 213

TRANSMISSION ASSEMBLY (CONT'D)

31. Ensure the number 6 thrust bearing is still stuck to back of the completed turbine shaft and front planetary assembly, as shown in Figure 214.
32. Install the completed turbine shaft and front planetary, as shown in Figure 214.
Note: Splines of the front carrier must engage into K1 clutch housing (See Figure 214).
33. Ensure number 2 thrust washer hardened race is still stuck to the K3 balance piston, as shown in Figure 215.
34. Install completed K3 clutch housing, as shown in Figure 215, by rotating back and forth until fully seated.

Note: K3 frictions must engage on the front planetary carrier and internal splines of the K3 clutch housing must engage external splines of sun gear shell.

34. Install the number 1 thrust washer, as shown in Figure 215, engaging tabs into the slots of the K3 clutch housing.

Continued on Page 121

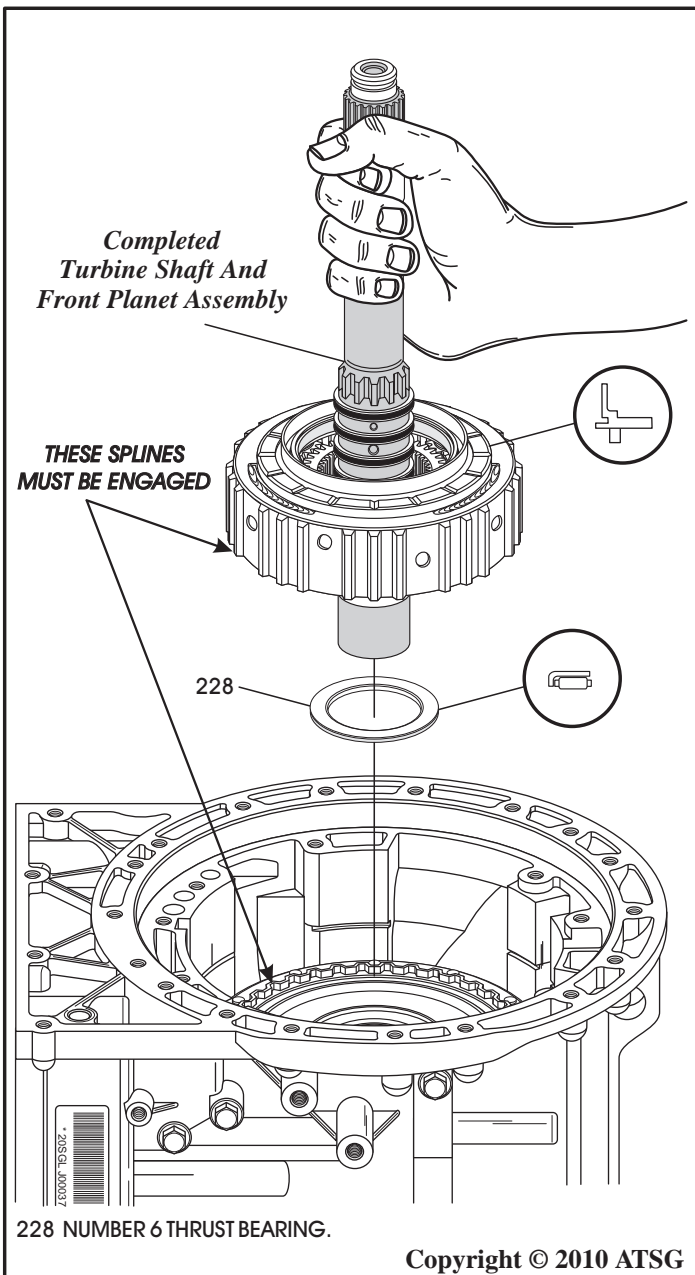
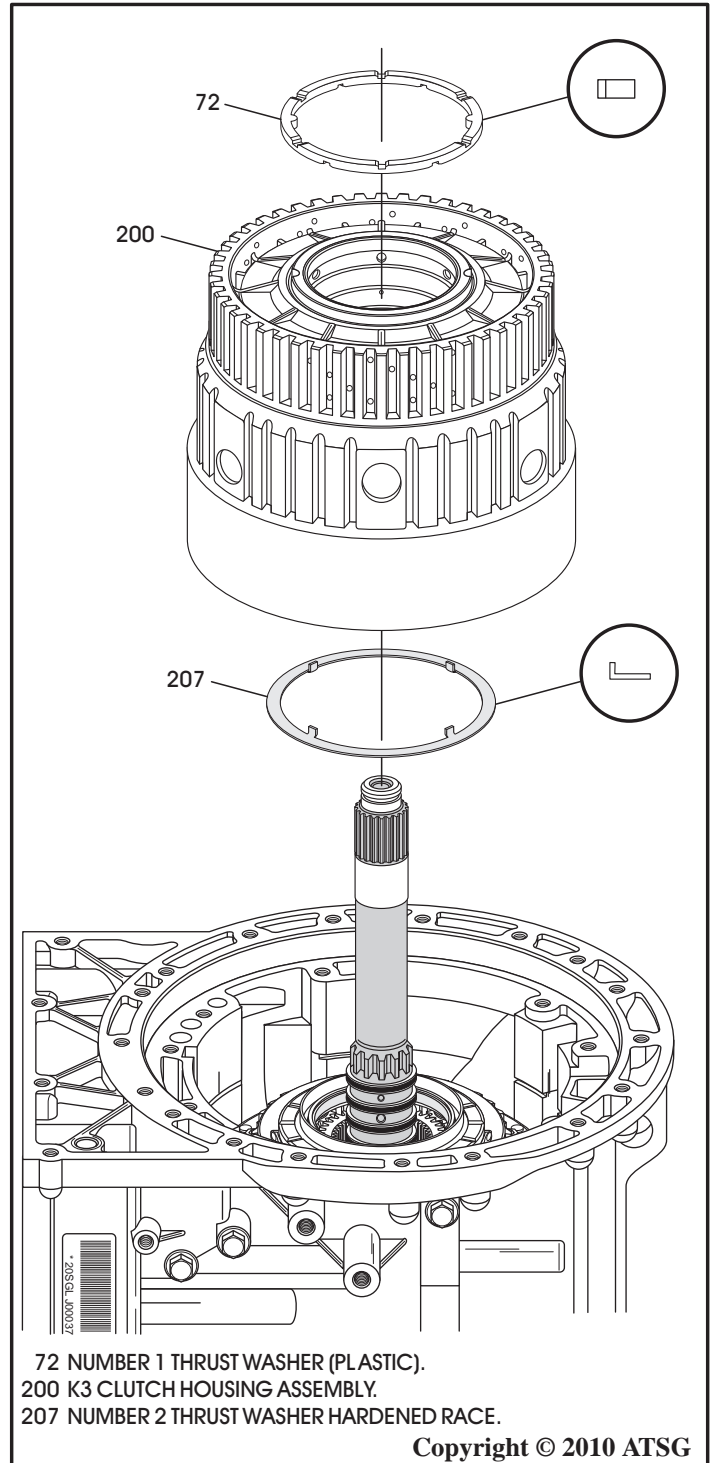

Figure 214



72 NUMBER 1 THRUST WASHER (PLASTIC).
200 K3 CLUTCH HOUSING ASSEMBLY.
207 NUMBER 2 THRUST WASHER HARDENED RACE.

Copyright © 2010 ATSG

Figure 215

TRANSMISSION ASSEMBLY (CONT'D)

35. Now is the time to compare the measurement you recorded during disassembly, as shown in Figure 216, to measurement that you now have.
Note: These measurements should be the same. If not, there is a clutch, a bearing or bearing race not fully seated.
36. Install the B1 clutch backing plate snap ring into the case, as shown in Figure 217, and ensure that it is fully seated in case groove.
37. Install the B1 clutch backing plate, as shown in Figure 217, with the rounded edge facing up toward the friction plate.

Continued on Page 122

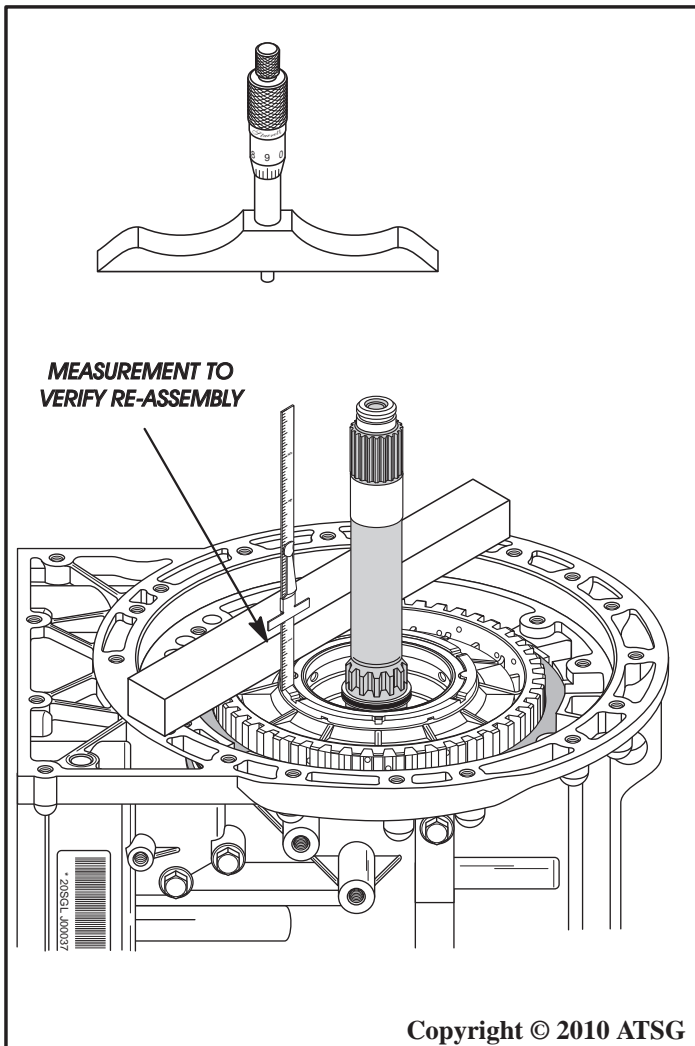

Figure 216

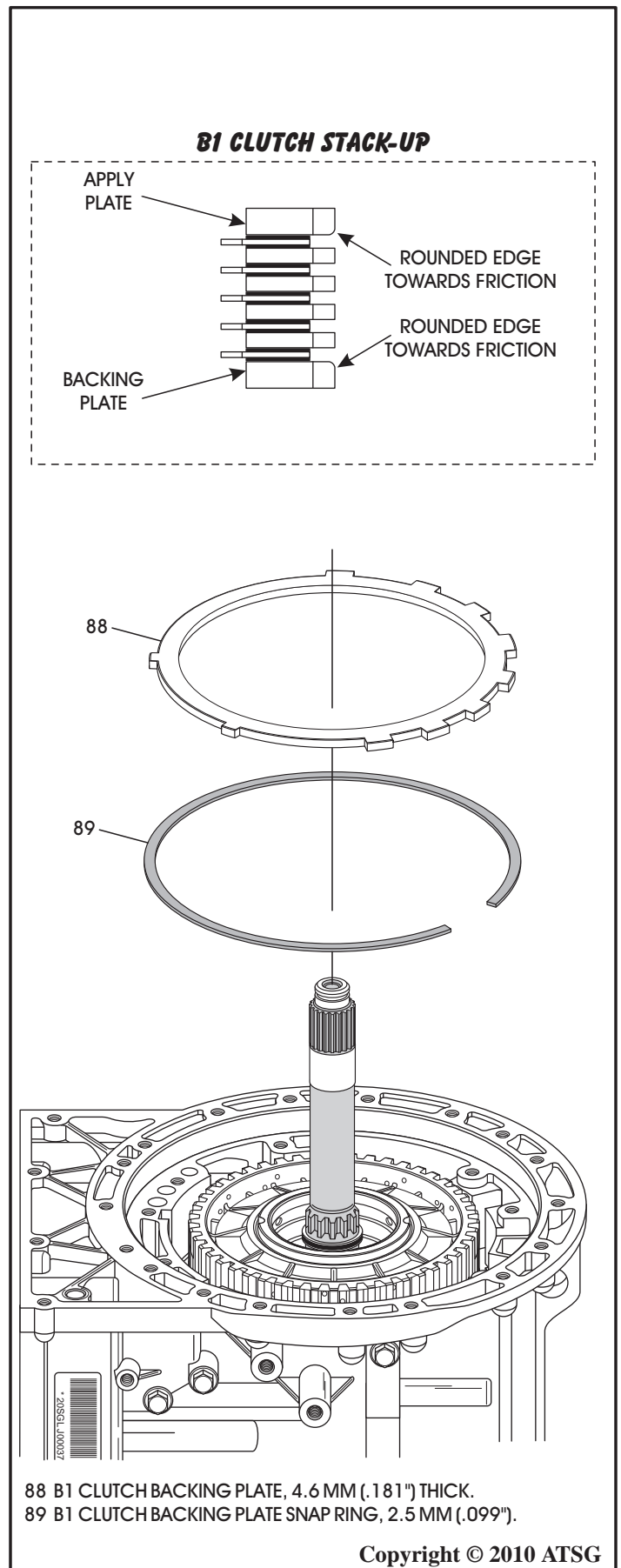

Figure 217

88 B1 CLUTCH BACKING PLATE, 4.6 MM (.181") THICK.
89 B1 CLUTCH BACKING PLATE SNAP RING, 2.5 MM (.099").

TRANSMISSION ASSEMBLY (CONT'D)

38. Install B1 clutch plates beginning with a friction plate and alternating with steel plates, as shown in Figure 219, until you have the proper amount installed as quantity may vary.
Note: All friction plates should be soaked in proper fluid for 30 minutes before installing.
39. Install B1 apply plate, as shown in Figure 219, with the "rounded" edge facing down toward the last friction, as shown in Figure 218.
40. Install the B1 "bellville" style cushion plate in the direction shown in Figure 219.

Continued on Page 123

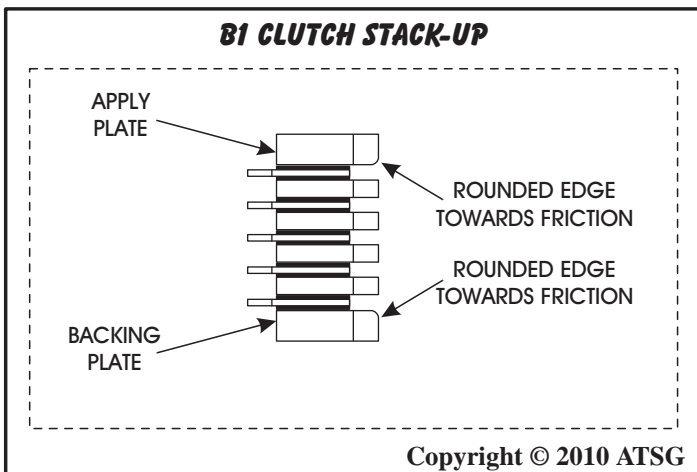
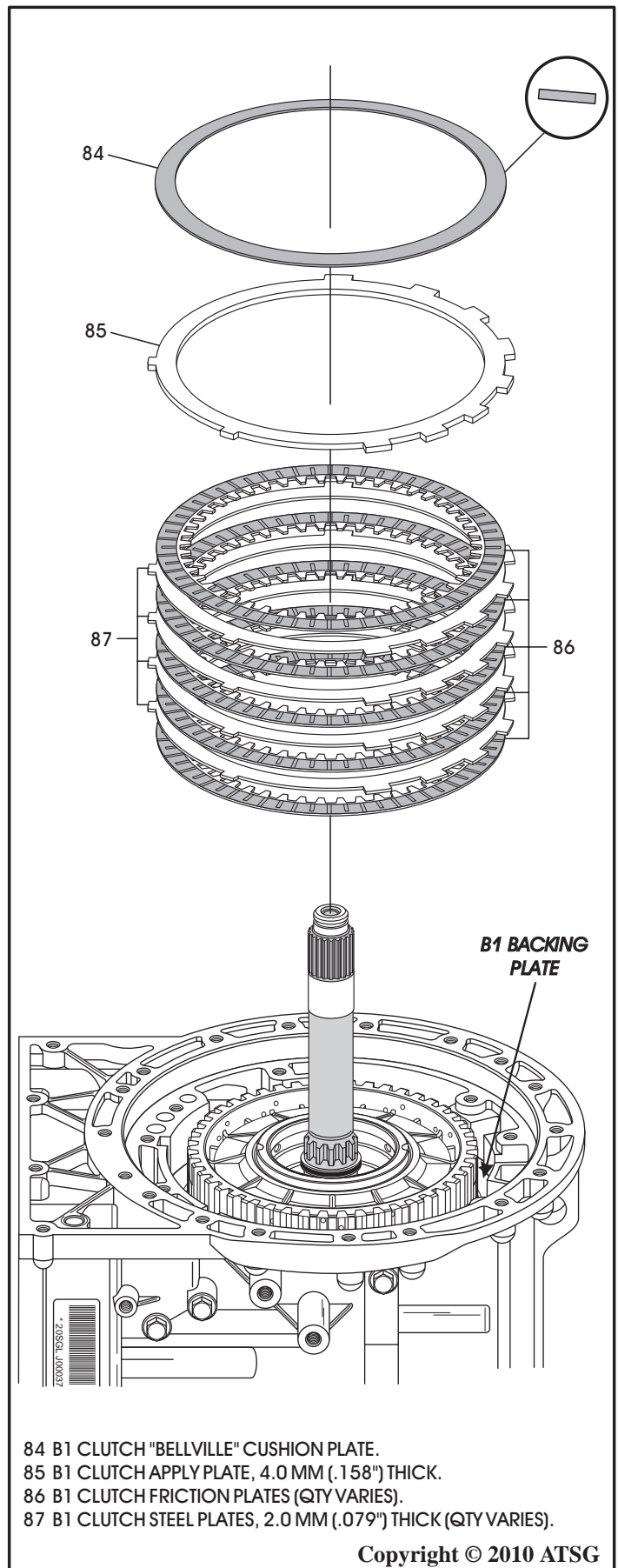

Figure 218

Figure 219

TRANSMISSION ASSEMBLY (CONT'D)

41. Install "H" gage on the transmission case pump surface, as shown in Figure 220, and lower the adjustment rod to the "high" point on the surface of the cushion plate and tighten adjustment rod locking knob.

Note: *Tip of adjustment rod must be resting on the "high" point of cushion plate, as shown in Figure 221.*

42. Now turn "H" gage over and set it on completed oil pump assembly, as shown in Figure 223, with adjustment rod over one leg of B1 clutch piston.
43. Measure with feeler gauge between adjustment rod and B1 clutch piston to determine the B1 clutch clearance, as shown in Figure 223.

Note: *There are no factory clutch clearance specifications available, but the clearances were the "traditional" .010" per friction plate through-out this unit.*

44. B1 clutch clearance should be approximately .010" per friction plate installed, as shown in Figure 223.

Continued on Page 124

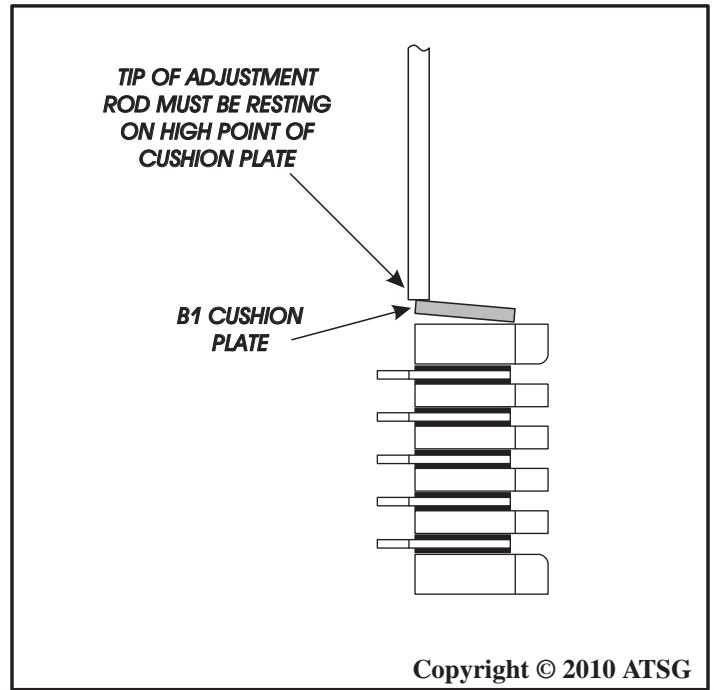

Copyright © 2010 ATSG

Figure 221

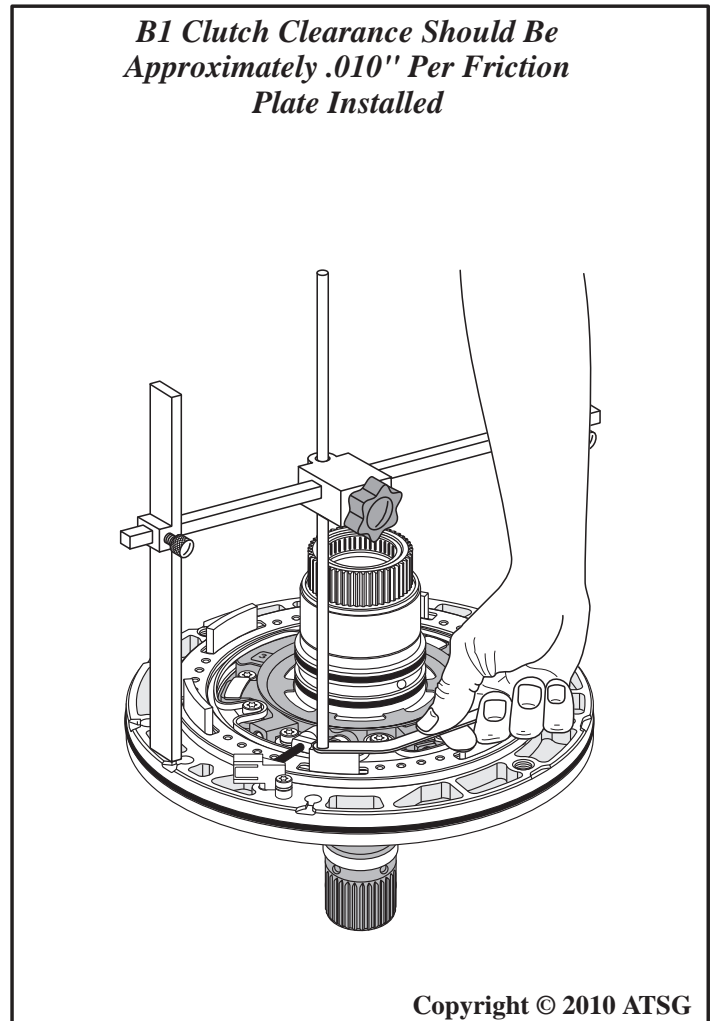

Copyright © 2010 ATSG

Figure 222

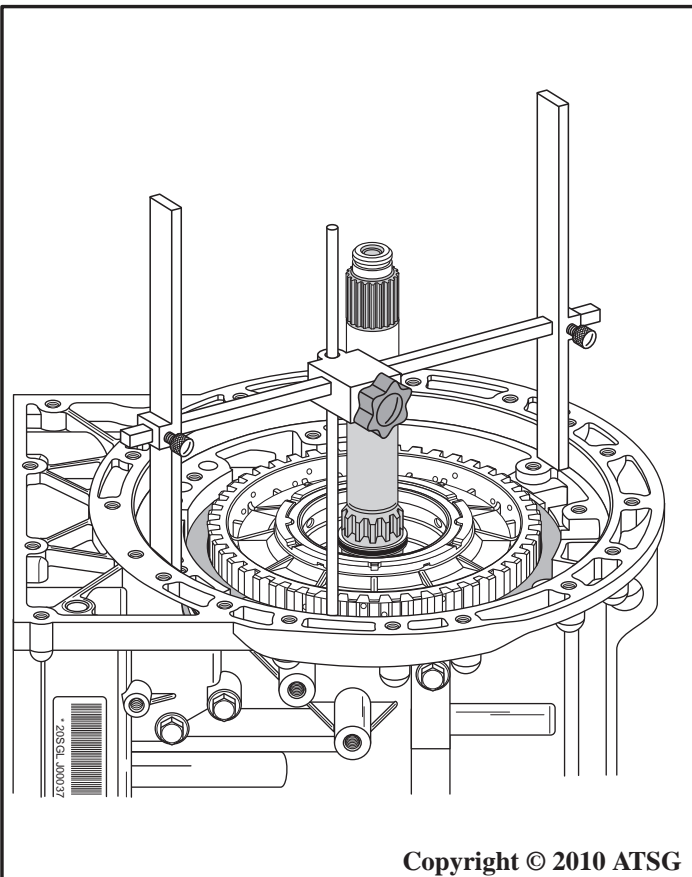

Copyright © 2010 ATSG

Figure 220

TRANSMISSION ASSEMBLY (CONT'D)

45. Install "H" gage on the transmission case pump surface, as shown in Figure 223, and lower the adjustment rod to the surface of the number 1 thrust washer and tighten the adjustment rod locking knob.

Note: There is no pump to case gasket used on the "09D" transmission to include in this measurement.

46. Now turn "H" gage over and set it on completed oil pump assembly, as shown in Figure 224, with adjustment rod over the number 1 thrust washer hardened race.
 47. Measure with feeler gauge between adjustment rod and hardened race to determine transmission end-play.
- Note: There are no selective washers available and no factory end-play specifications available.*
48. Transmission end-play for this unit should be 0.304 MM (.012") to 0.609 MM (.024").
 49. Ensure number 1 thrust washer is still in place on the K3 clutch housing (See Figure 225).

Continued on Page 125

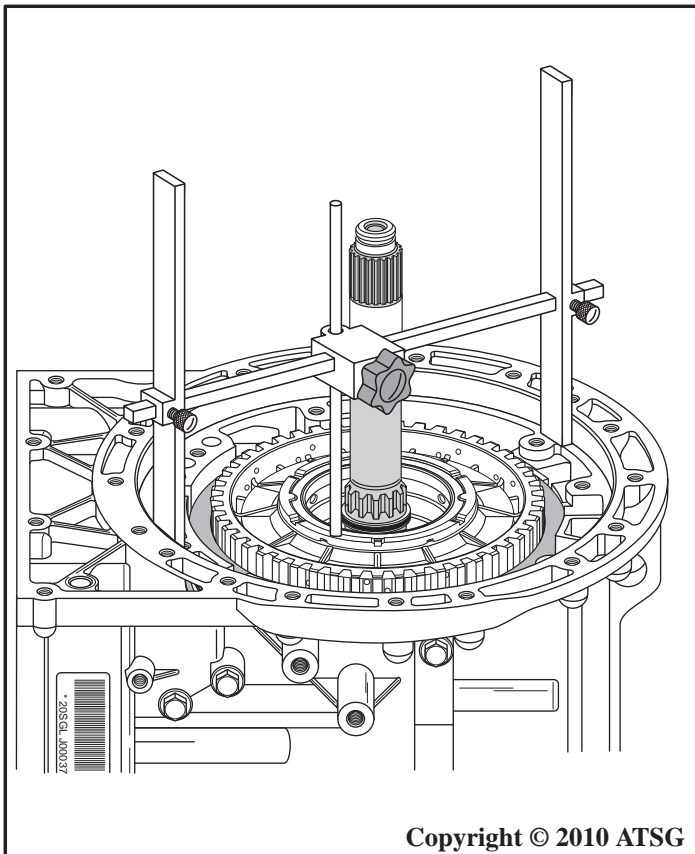

Figure 223

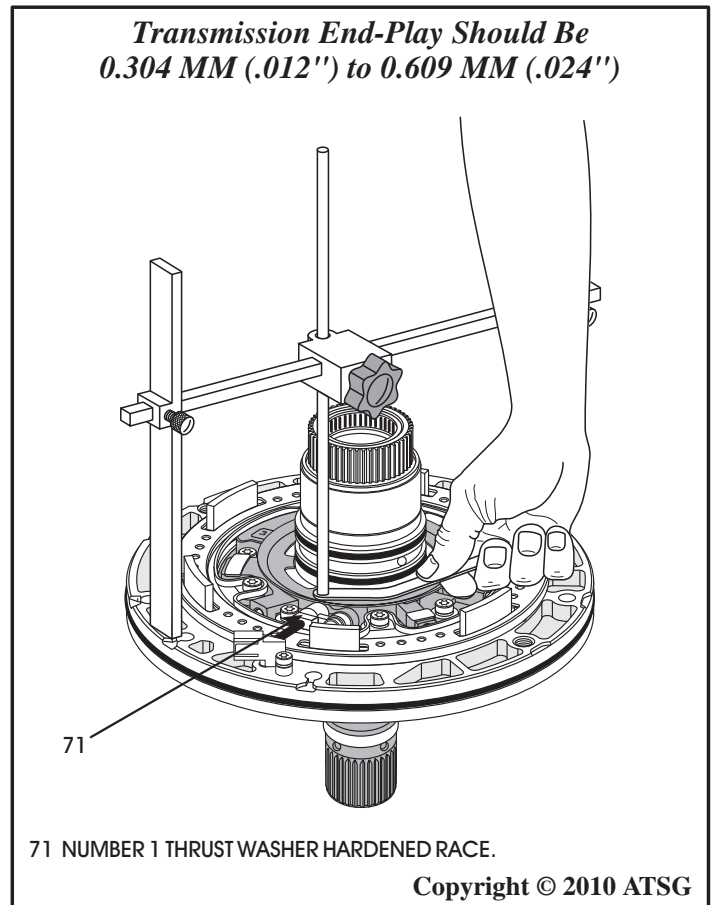

Figure 224

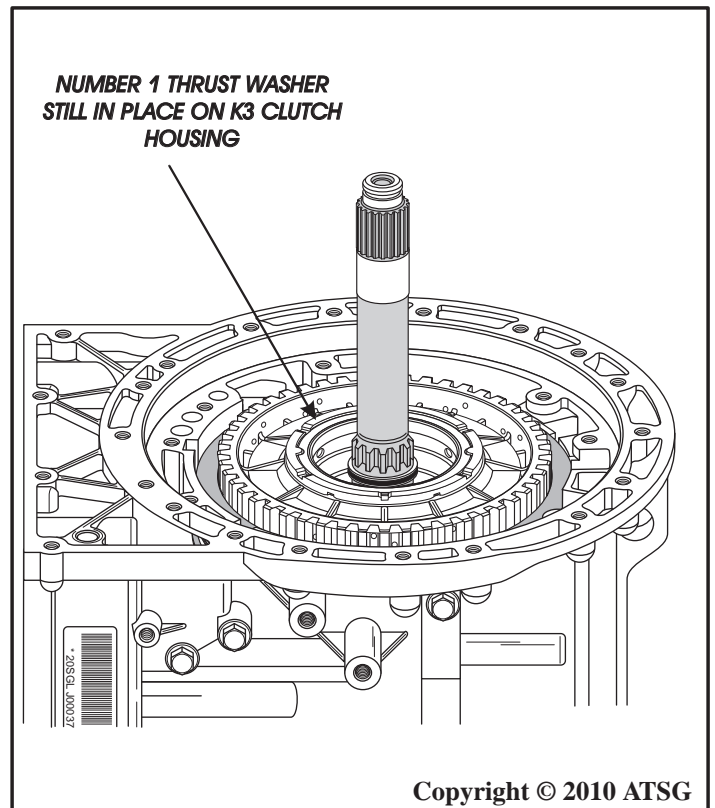

Figure 225

TRANSMISSION ASSEMBLY (CONT'D)

50. Install completed oil pump assembly, as shown in Figure 226.
Note: You may have to rotate the turbine shaft which will rotate the front sun gear which must engage on splines of pump cover, for the pump to be fully seated.
51. Once the pump is fully seated, install the ten oil pump retaining bolts, as shown in Figure 227.
52. Torque all ten of the oil pump retaining bolts to 27 N·m (20 ft.lb.) using a criss-cross pattern, as shown in Figure 228.

Continued on Page 126

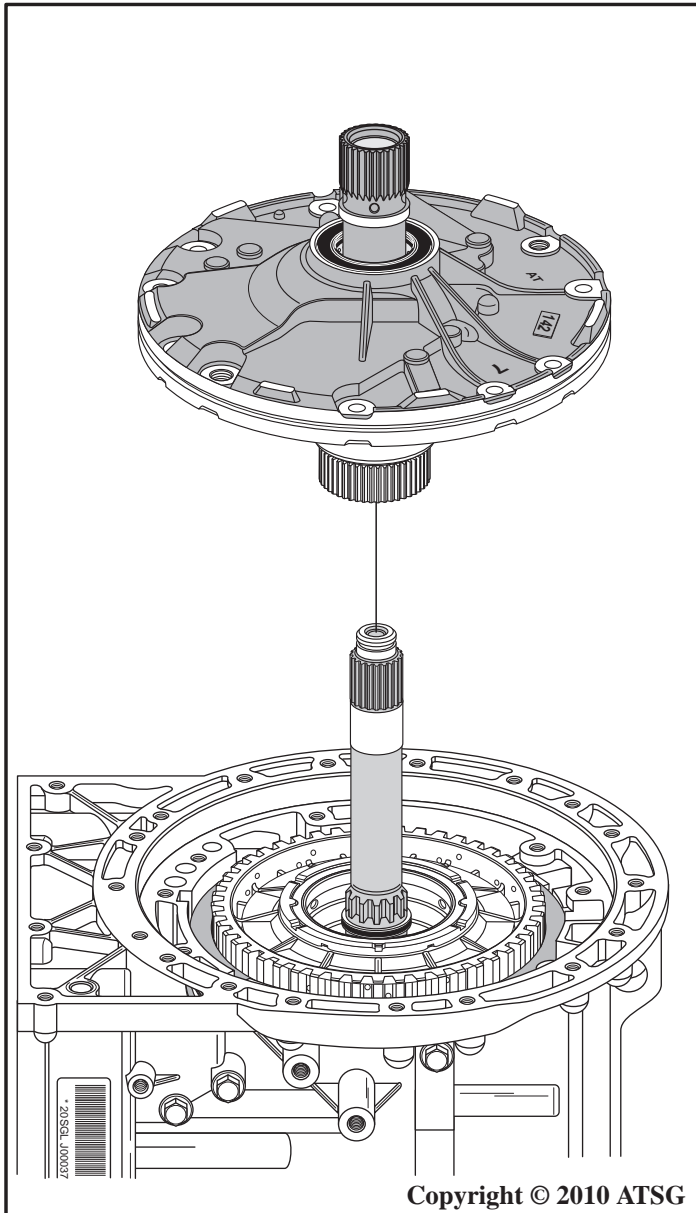
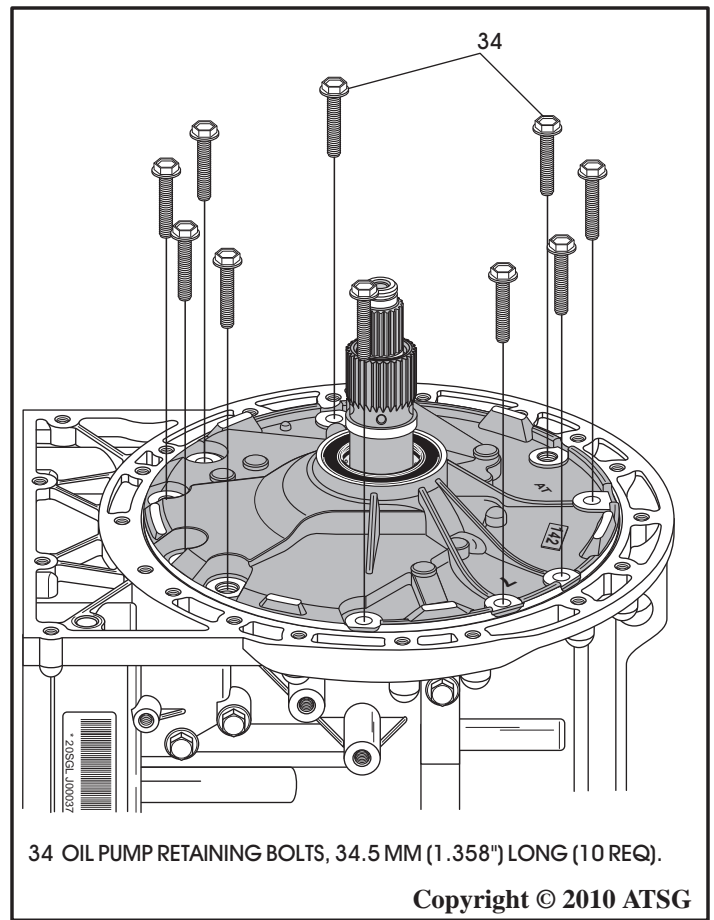

Figure 226



34 OIL PUMP RETAINING BOLTS, 34.5 MM (1.358") LONG (10 REQ).

Copyright © 2010 ATSG

Figure 227

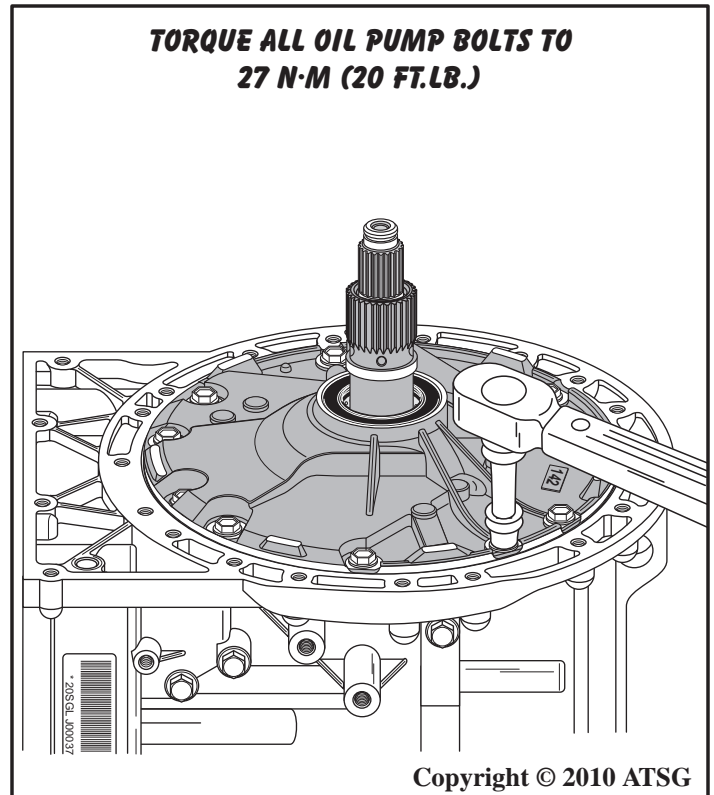

Copyright © 2010 ATSG

Figure 228

TRANSMISSION ASSEMBLY (CONT'D)

53. Now set transmission on work bench with the pan surface facing up, as shown in Figure 229.
54. Install the completed valve body assembly, as shown in Figure 229.

Note: Ensure manual valve is engaged with the inside detent lever (See Figure 230).

55. Install the 14 valve body to case bolts in their proper locations using Figure 231 as a guide.
56. Torque all fourteen valve body to case bolts to 11 N·m (97 in.lb.).

Continued on Page 127

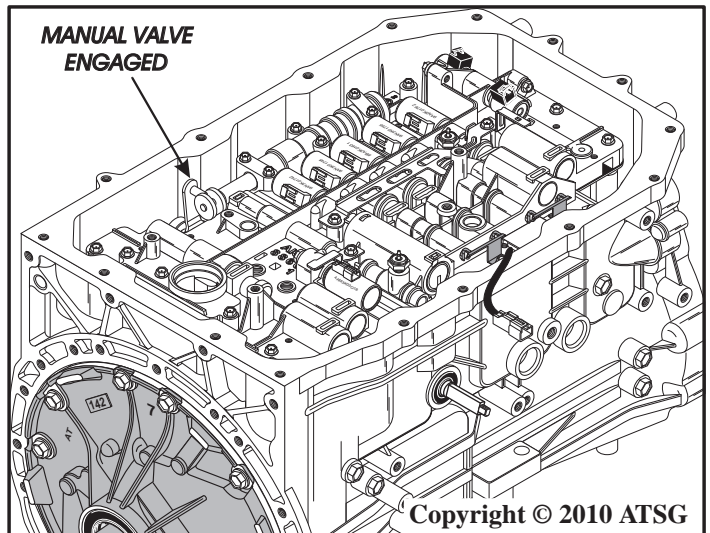

Copyright © 2010 ATSG

Figure 230

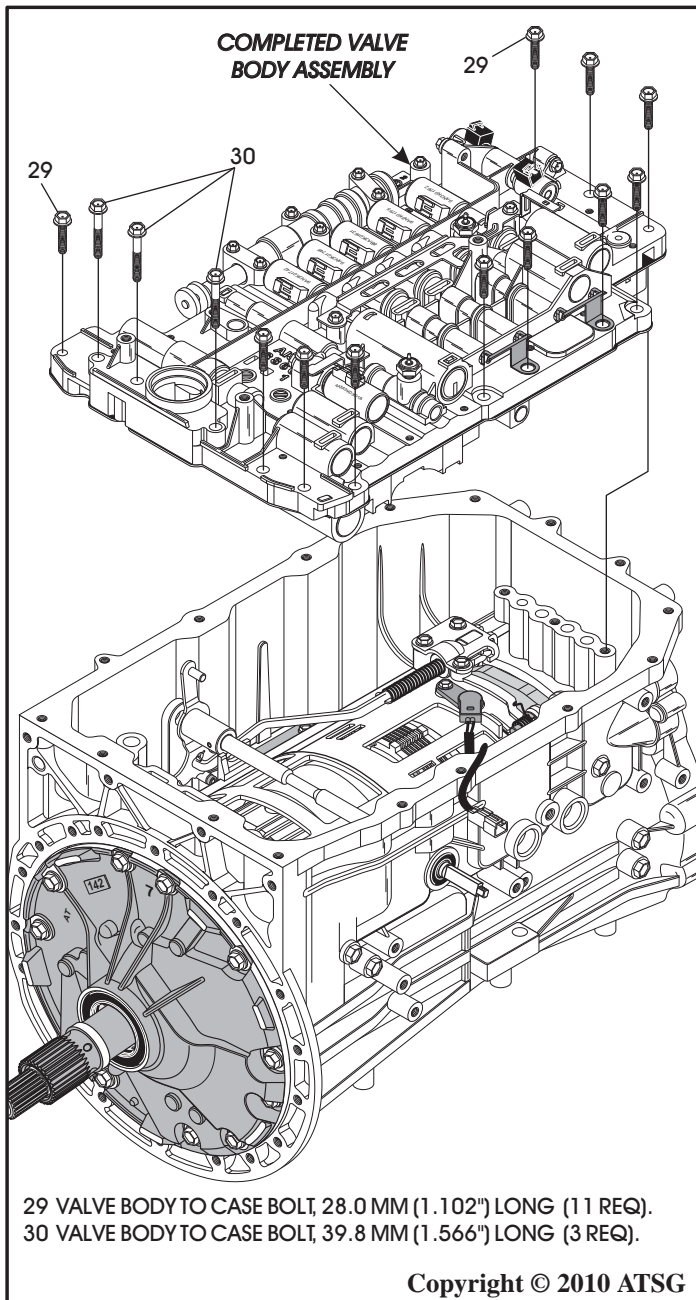

29 VALVE BODY TO CASE BOLT, 28.0 MM (1.102") LONG (11 REQ).
 30 VALVE BODY TO CASE BOLT, 39.8 MM (1.566") LONG (3 REQ).

Copyright © 2010 ATSG

Figure 229

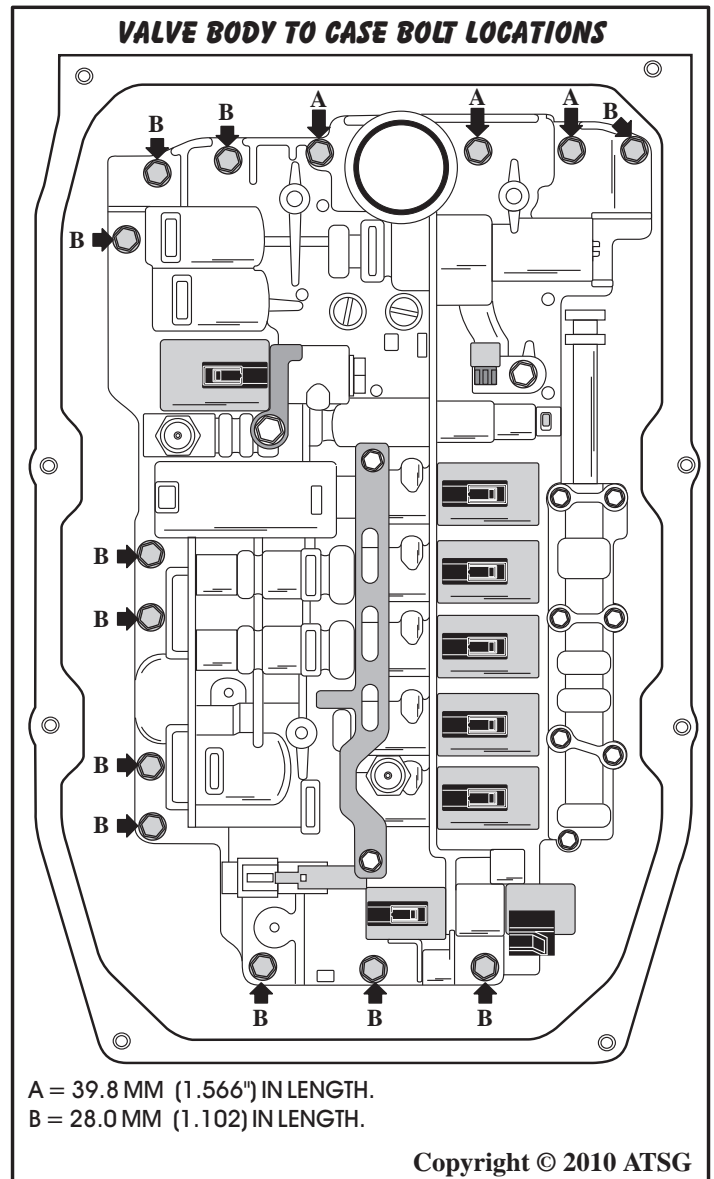

A = 39.8 MM (1.566") IN LENGTH.
 B = 28.0 MM (1.102") IN LENGTH.

Copyright © 2010 ATSG

Figure 231

TRANSMISSION ASSEMBLY (CONT'D)

57. Install White OSS harness connector onto the solenoid retaining bracket (See Figure 232).
58. Install new "O" ring seals on both pass-thru case connector and wire harness assemblies and install them into their proper case bores, as shown in Figure 233.
59. Install the retaining "stud" bolt, as shown in Figure 233, torque to 11 N·m (97 in.lb.).
60. Install new "O" ring seal onto temp sensor, as shown in Figure 233.

Continued on Page 128

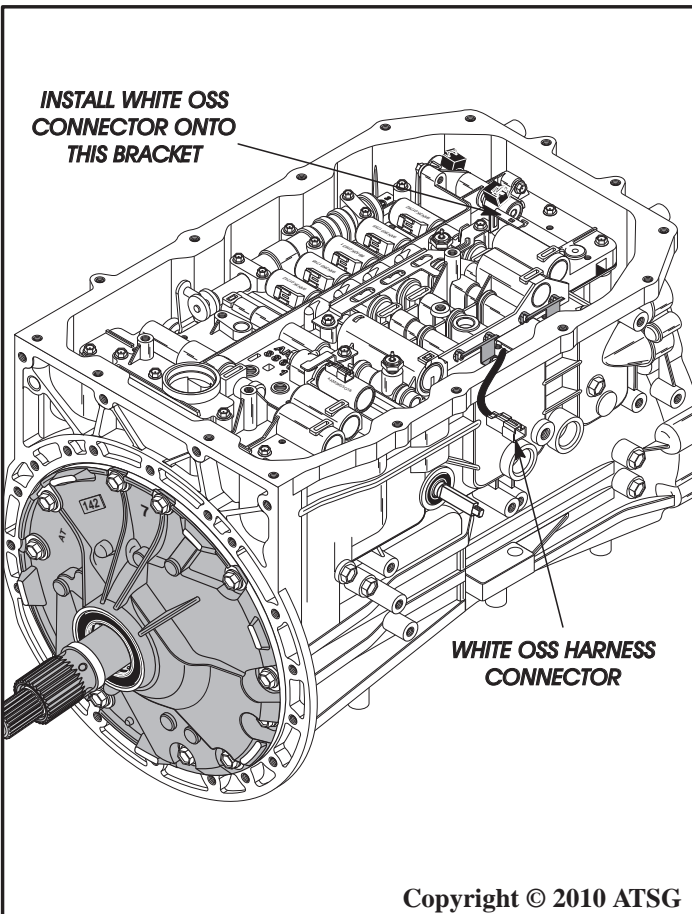

Figure 232

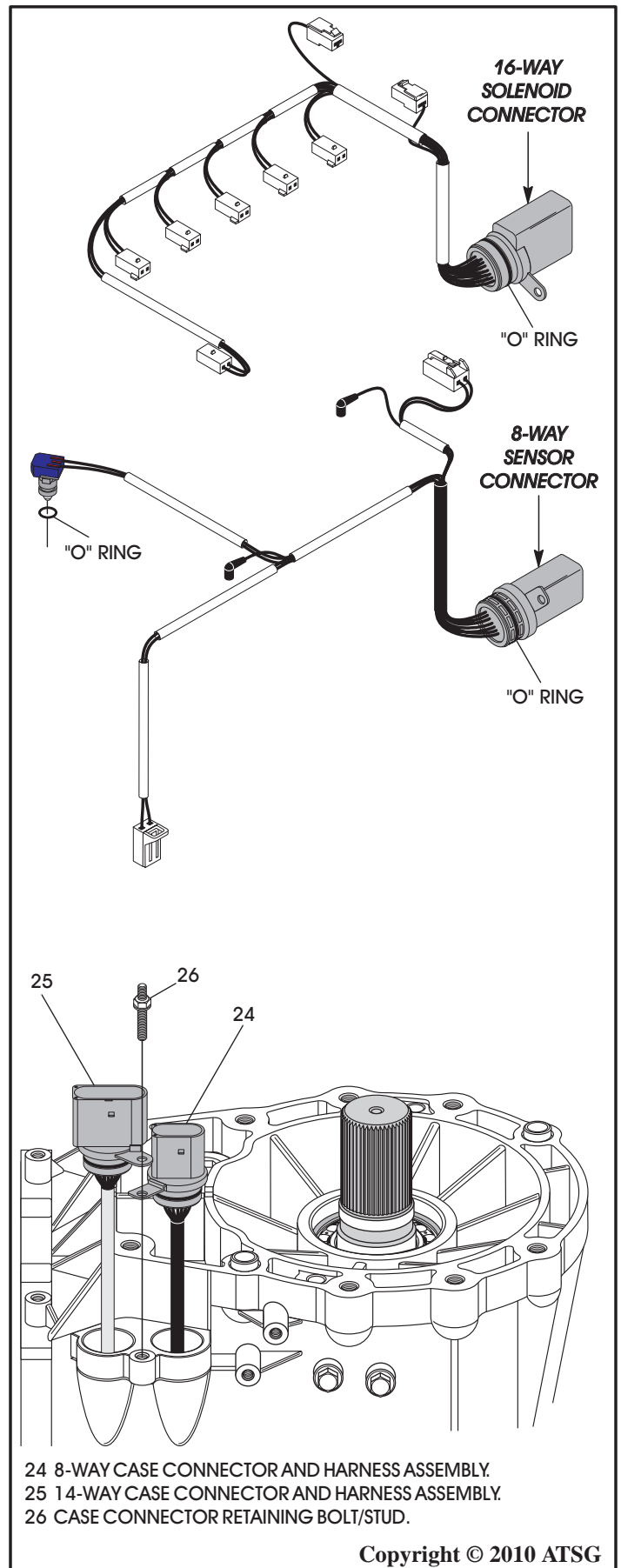

Figure 233

TRANSMISSION ASSEMBLY (CONT'D)

61. Install transmission temp sensor into valve body, as shown in Figure 234, install retaining bracket and torque to 11 N·m (97 in.lb.).
62. Connect White OSS sensor connector to White connector on solenoid bracket (See Figure 235).
63. Connect Yellow ISS sensor connector to Yellow connector located on oil pump (See Figure 235).
64. Connect all solenoids using the chart that you prepared during disassembly (See Figure 235).
65. Install new "O" ring seal on new oil filter as shown in Figure 236, and lube "O" ring with a small amount of Trans-Jel®.
66. Install oil filter and torque the 3 retaining bolts to 11 N·m (97 in.lb.) (See Figure 236).

Continued on Page 129

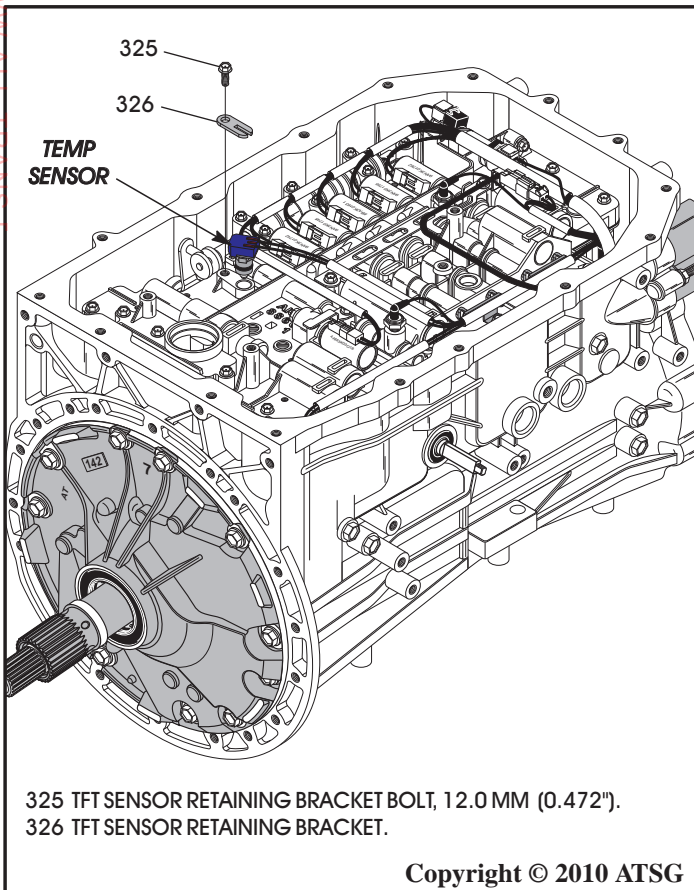

Figure 234

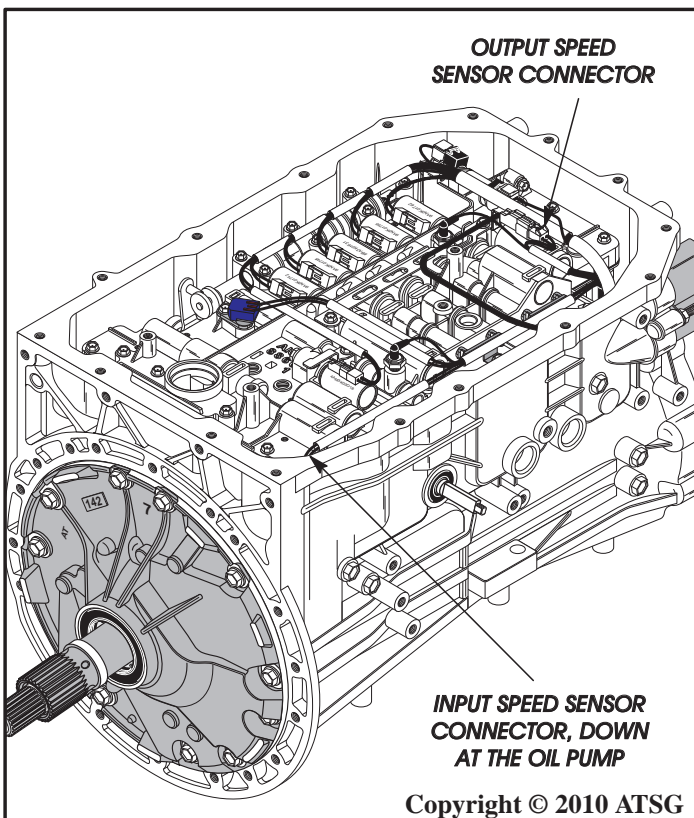

Figure 235

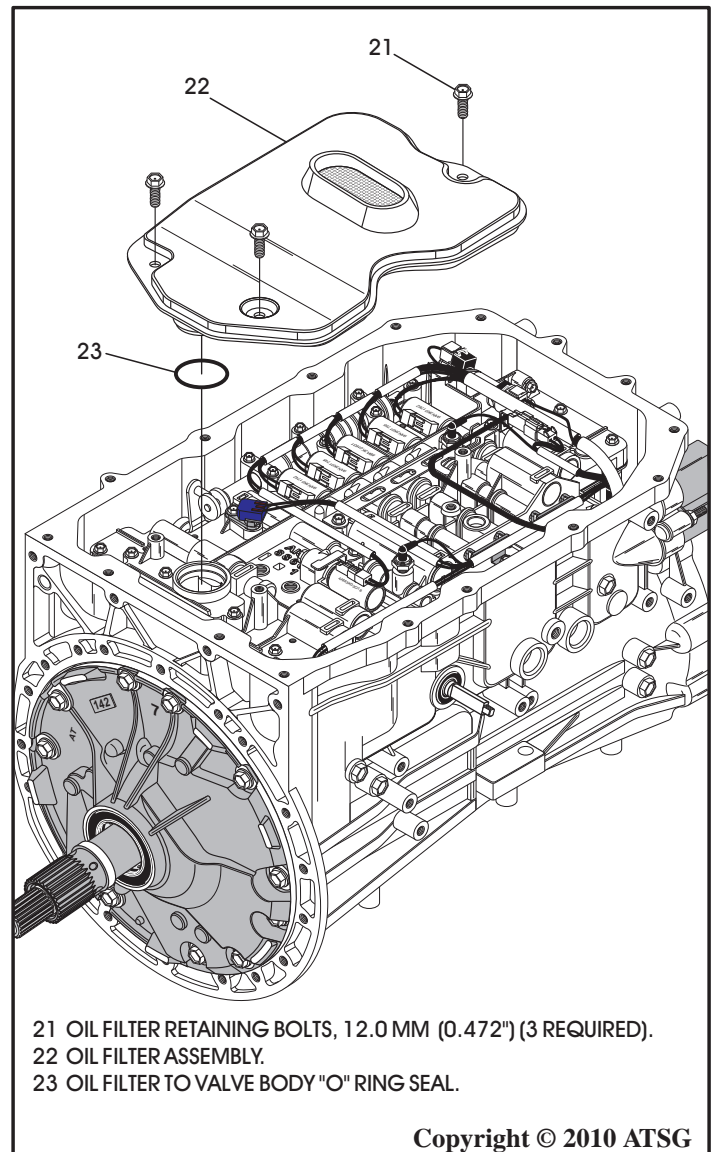

Figure 236

TRANSMISSION ASSEMBLY (CONT'D)

67. Install the five oil pan magnets between the ribs provided in the oil pan, as shown in Figure 237.
68. Install new oil pan gasket on the oil pan, as shown in Figure 238.
69. Install the oil pan and gasket onto the case, as shown in Figure 238.
70. Install the required amount of oil pan retaining bolts and torque to 11 N·m (97 in.lb.).
Note: Some models require 8 bolts and some models require 16 bolts as cases are different. Refer to Page 28.
71. Install new "O" ring on oil pan "check" plug, as shown in Figure 238, and torque check plug to 28 N·m (20 ft.lb.).

Continued on Page 130

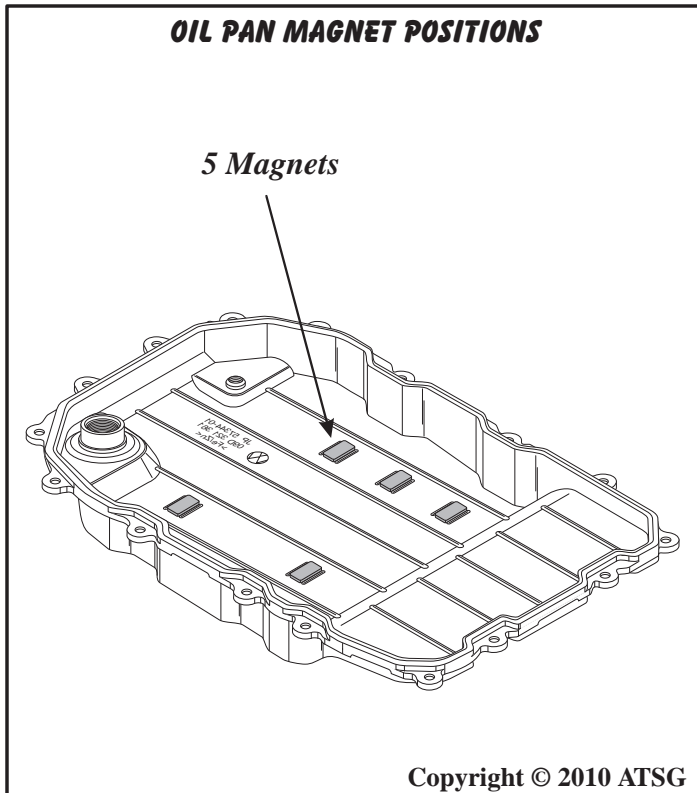

Figure 237

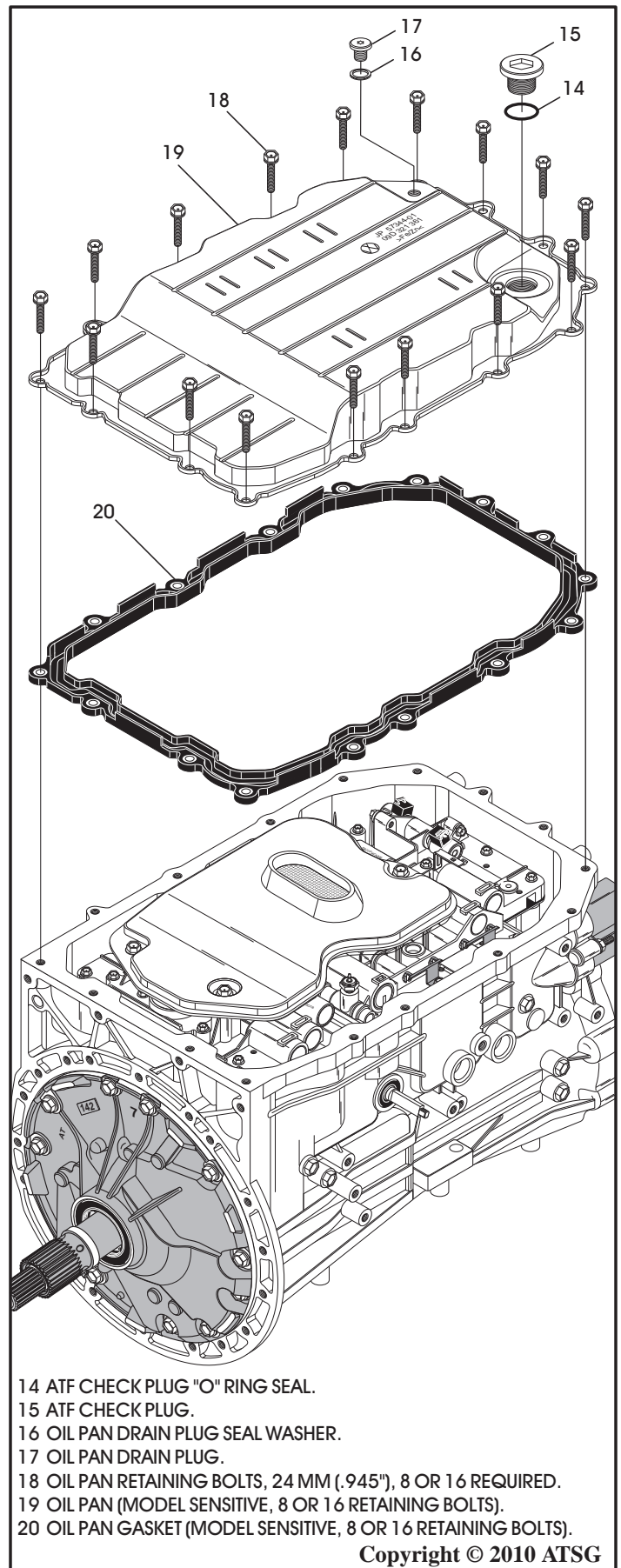

Figure 238

TRANSMISSION ASSEMBLY (CONT'D)

72. If you are working on a 4WD version you should have already installed the rear seal during case component assembly. If not, install the rear seal as shown in Figure 239.
73. If you are working on a 2WD version, as shown in Figure 240, install the rear seal.
74. Install mounting plate, as shown in Figure 240, and the eight mounting plate retaining bolts.
75. Torque the eight mounting plate bolts down to 55 N·m (40 ft.lb.).
76. Install the drive shaft yoke and retaining nut, as shown in Figure 240, and torque retaining nut to 82 N·m (60 ft.lb.).
77. Stake the nut in place into the groove in threads in the output shaft using a punch.

Continued on Page 131

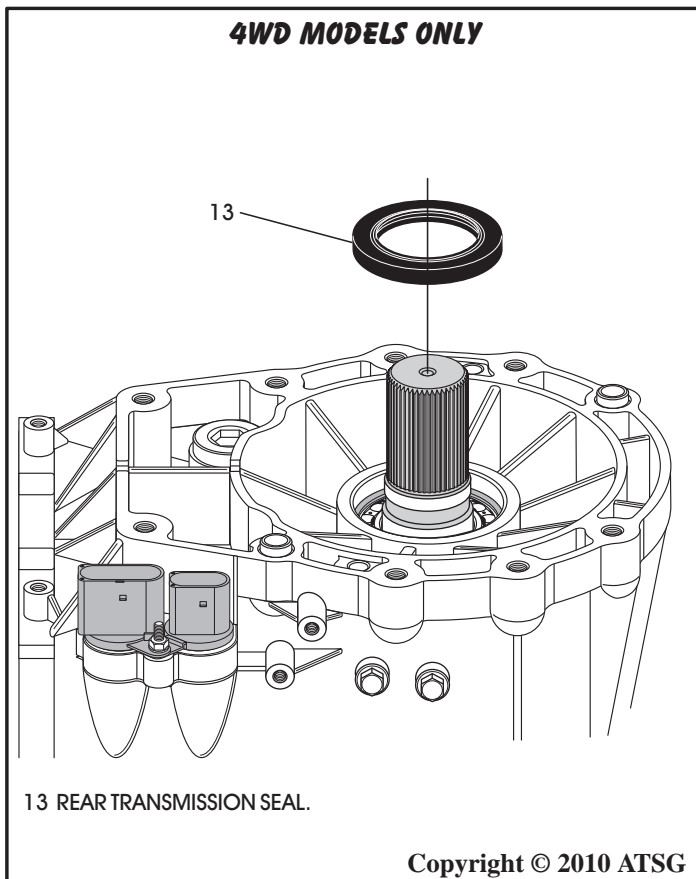

Figure 239

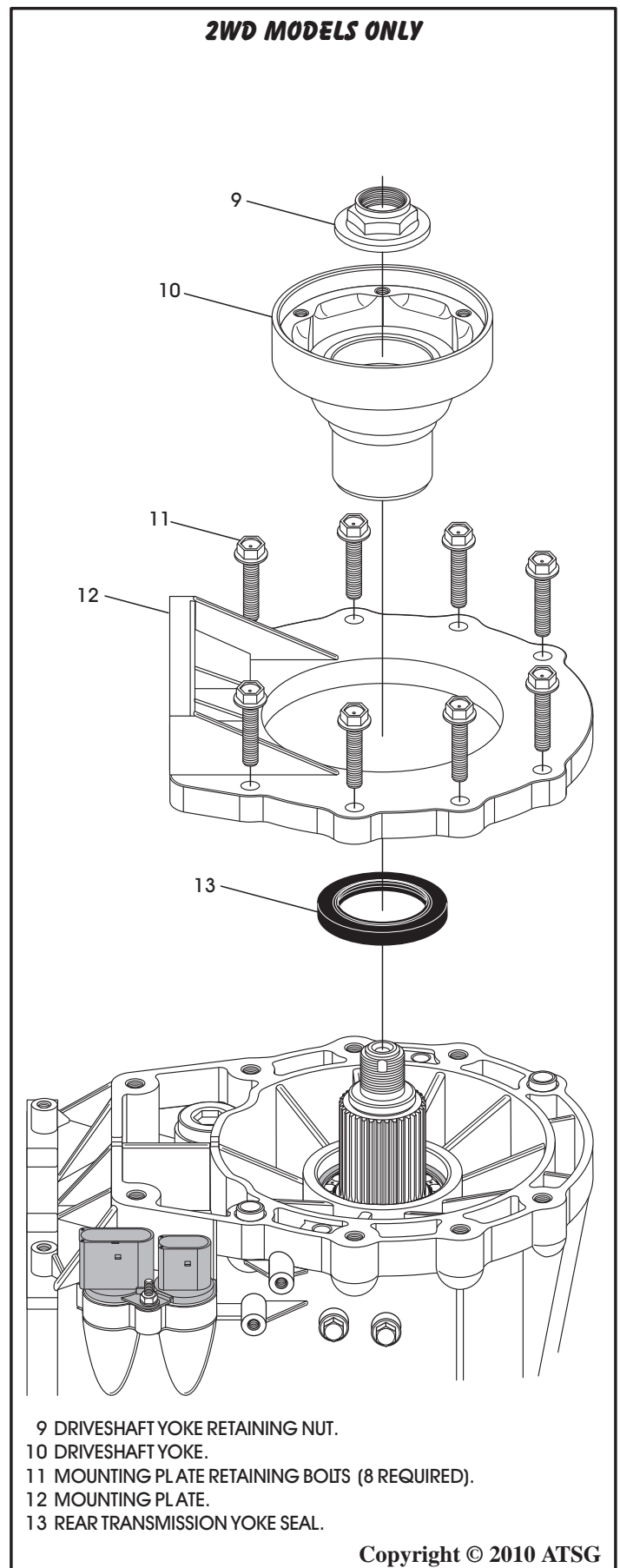

Figure 240

TRANSMISSION ASSEMBLY (CONT'D)

78. Install the transmission range (multifunction) switch, as shown in Figure 241.
Note: If the range (multifunction) switch is removed or replaced, a position to the manual selector shaft must be set using a special tool available from Volkswagen.
79. Set the position to the manual shaft and torque the 2 bolts to 10 N·m (89 in.lb.).
80. Install the debris shield and acorn nut, as shown in Figure 241.

81. Some models of the "09D" family route line pressure through the converter housing and will require two "O" ring seals on the back side of converter housing, as shown in Figure 242.
82. Retain the "O" ring seals with a small amount of Trans-Jel®.

Continued on Page 132

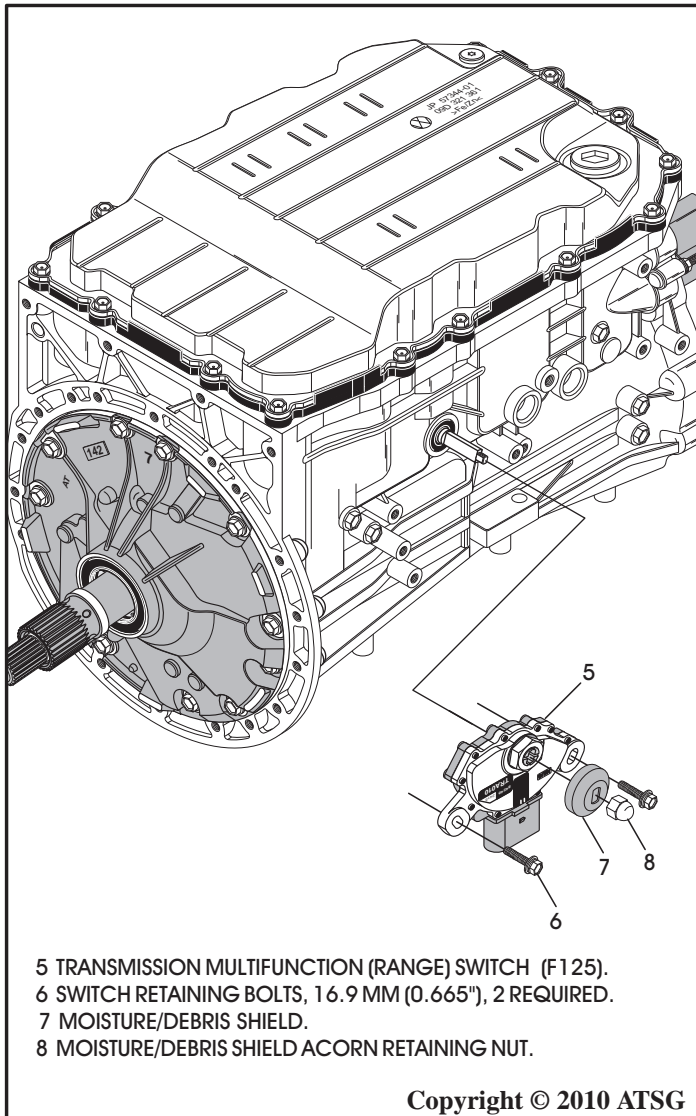

Figure 241

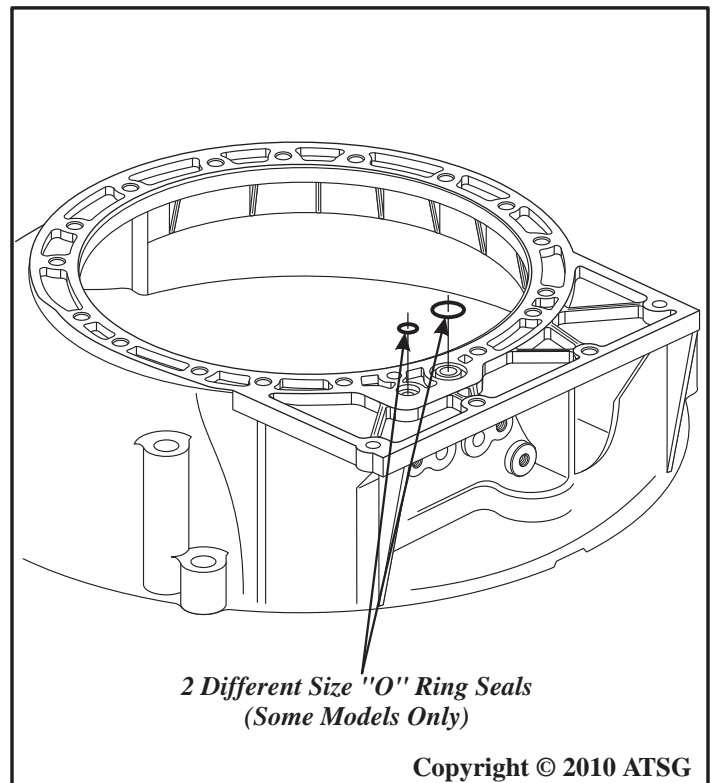

Figure 242

WWW.ALL-TRANS.BY

TRANSMISSION ASSEMBLY (CONT'D)

83. Install turbine shaft "O" ring seal into groove in turbine shaft, as shown in Figure 244.
Note: Turbine shaft "O" ring is used on the 3 port converter models only.
84. Install the torque converter housing, as shown in Figure 244.
85. Install the 22 converter housing retaining bolts, as shown in Figure 244.
Note: See Figure 243 for locations.
86. Torque all 22 converter housing retaining bolts to 27 N·m (20 ft.lb.), using a 12 MM socket.
Note: Four of the converter housing bolts are behind the face of housing, as shown in Figure 243.
87. Install the proper torque converter, as shown in Figure 245.

**CONGRATULATIONS
YOU ARE FINISHED!**

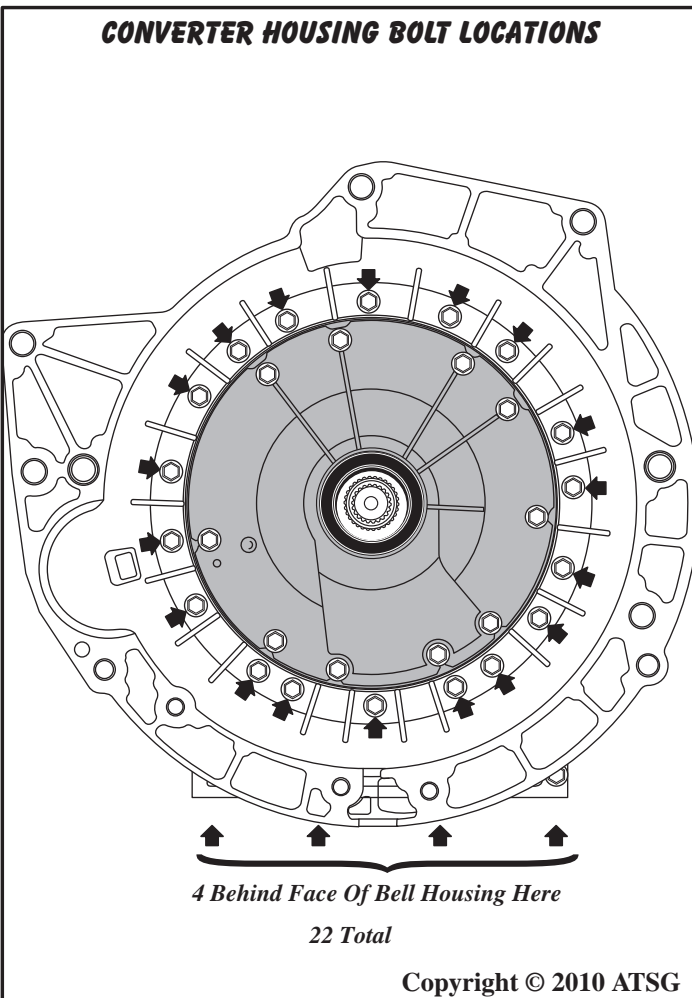

Figure 243

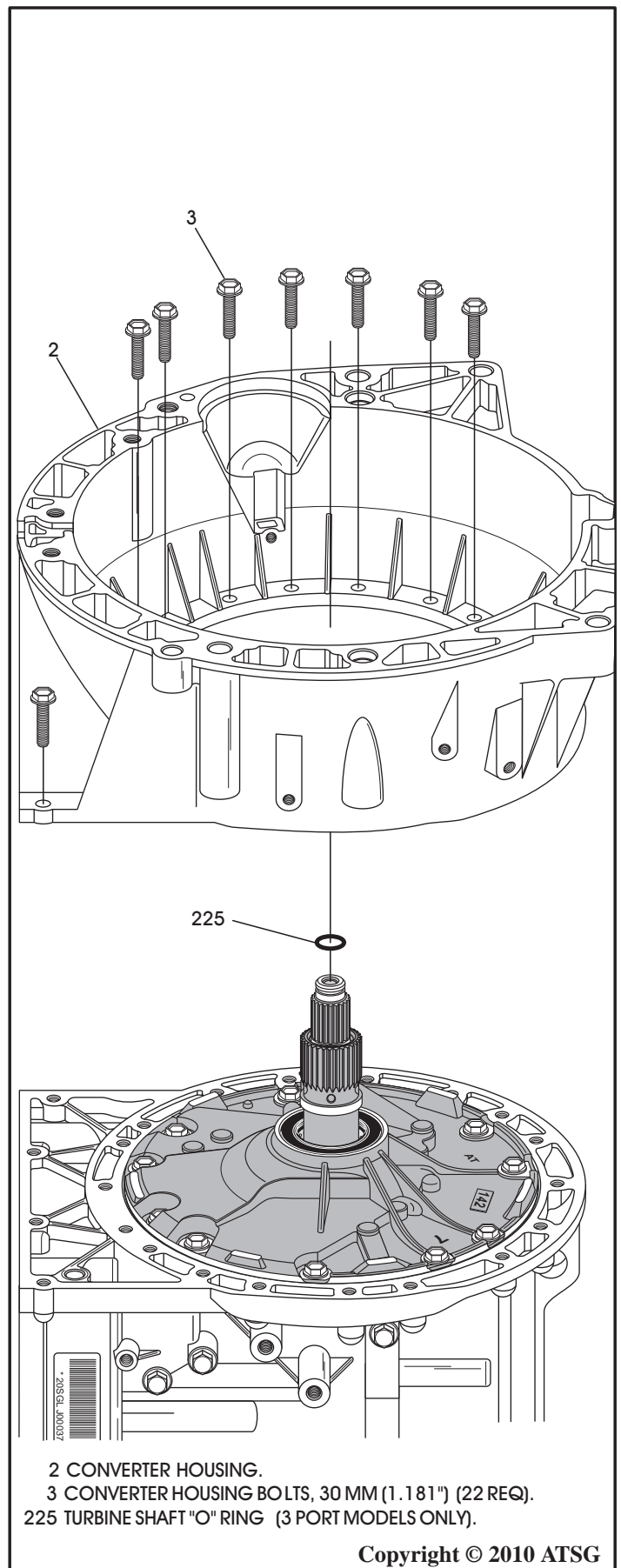

Figure 244

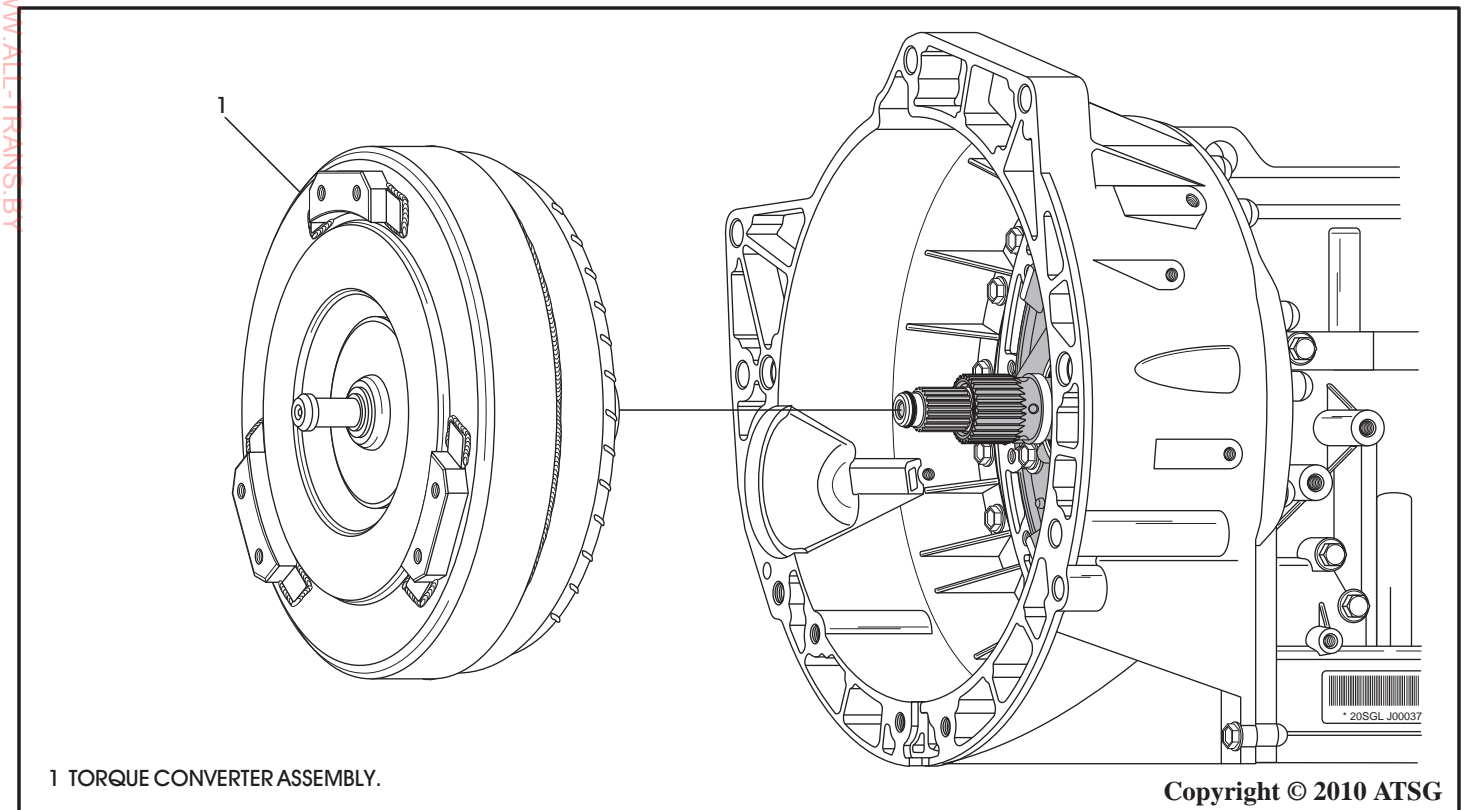
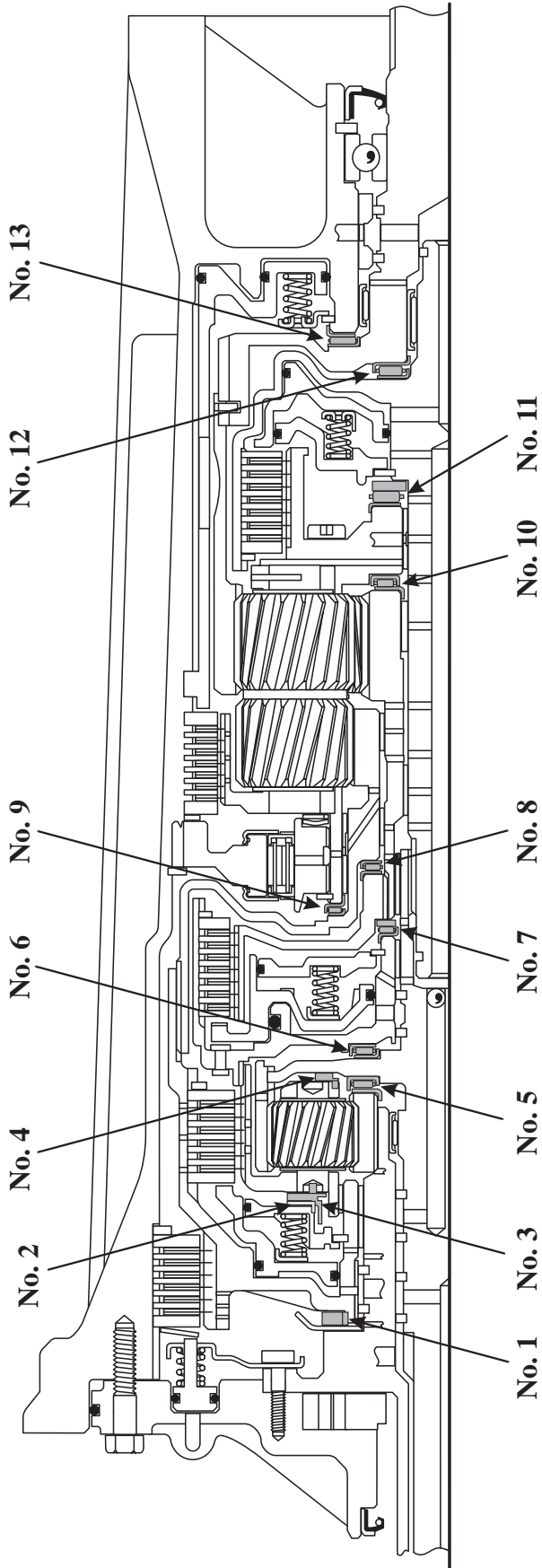

Figure 245

TORQUE SPECIFICATIONS			
Component	N•m	Ft.Lb.	In.Lb.
Converter Housing to Case	28	20	
Oil Pump to Case	28	20	
Oil Pump Cover to Pump Body	18	13	
Manual Valve Body	10		89
Upper VB to Lower VB and Linear Solenoid Brackets	10		89
Inside Detent Spring to Case	11		97
Park Rod Guide to Case	28	20	97
Valve Body to Case Bolts	11		97
8-Way and 14-Way Case Connectors to Case	11		97
Temp Sensor to Valve Body	11		97
Oil Pan Drain Plug	28	20	
Oil Pan to Case	11		97
Oil Screen to Valve Body	11		97
Oil "Check" Plug	28	20	
2WD Mounting Plate	55	40	
2WD Driveshaft Yoke Nut	82	60	
Output Speed Sensor to Case and OSS Harness Bracket	11		97
Input Speed Sensor to Pump Cover and ISS Connector to Pump Body	6		53
Transmission Range (Multifunction) Switch to Case	10		89
<p><i>Note: Some torque specifications are based on the findings in a virgin unit that was torn down. The manufacturer does not provide any factory torque specifications.</i></p> <p>Copyright © 2010 ATSG</p>			

Figure 246

THRUST BEARING AND THRUST WASHER LOCATIONS



- NO. 1: THRUST WASHER, OIL PUMP TO K3 CLUTCH HOUSING, WHITE PLASTIC, 4.78 MM (.188") THICK AND PROBABLY SELECTIVE.
- NO. 2: THRUST WASHER, K3 CLUTCH HOUSING TO NUMBER 3 THRUST WASHER, HARDENED RACE FOR NO.3 THRUST WASHER.
- NO. 3: THRUST WASHER, FRONT SIDE OF FRONT CARRIER TO NO. 2 HARDENED RACE IN K3 CLUTCH HOUSING, WHITE PLASTIC.
- NO. 4: THRUST WASHER, REAR SIDE OF FRONT CARRIER TO FRONT RING GEAR THRUST WASHER, WHITE PLASTIC.
- NO. 5: THRUST BEARING, FRONT SUN GEAR TO FRONT RING GEAR.
- NO. 6: THRUST BEARING, FRONT RING GEAR TO K1 CLUTCH HOUSING.
- NO. 7: THRUST BEARING, K1 CLUTCH HOUSING TO K1 CLUTCH HUB.
- NO. 8: THRUST BEARING, K1 CLUTCH HUB TO LARGE REAR SUN GEAR AND DRIVE SHELL.
- NO. 9: THRUST BEARING, LARGE SUN GEAR AND DRIVE SHELL TO REAR PLANETARY CARRIER.
- NO. 10: THRUST BEARING, SMALL SUN GEAR TO REAR PLANETARY CARRIER.
- NO. 11: THRUST BEARING, REAR PLANETARY CARRIER TO K2 CLUTCH HOUSING.
- NO. 12: THRUST BEARING, K2 CLUTCH HOUSING TO OUTPUT SHAFT.
- NO. 13: THRUST BEARING, OUTPUT SHAFT TO TRANSMISSION CASE.

Copyright © 2010 ATSG

Figure 247

THRUST WASHER AND BEARING IDENTIFICATION

NUMBER 1

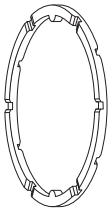

NUMBER 2

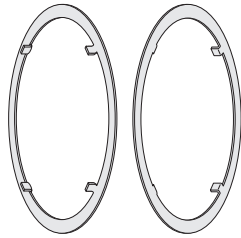

NUMBER 3

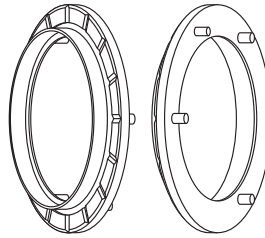

NUMBER 4

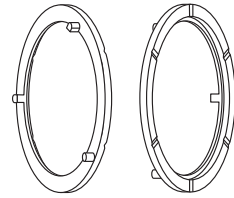

NUMBER 5

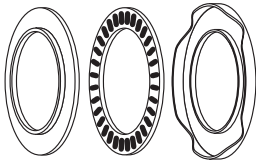

NUMBER 6

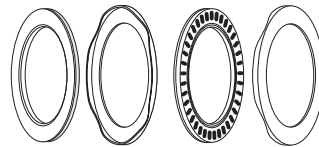

NUMBER 7

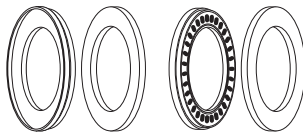

NUMBER 8

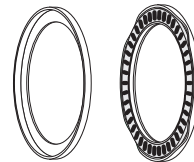

NUMBER 9

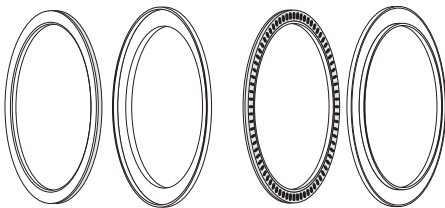

NUMBER 10



NUMBER 11

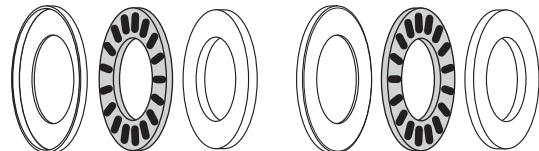

NUMBER 12

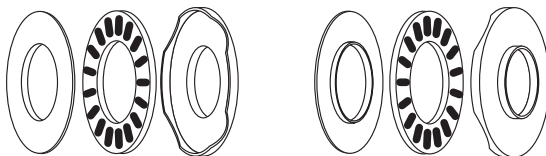

NUMBER 13

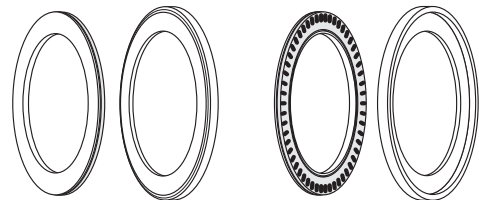

Copyright © 2010 ATSG

Figure 248



WWW.ALL-TRANS.BY

Notes

A large, empty rectangular box with a thin black border, intended for handwritten notes.